

Intelligent MP Series

Up to 1500 Watts

Total Power: Up to 1500 Watts
Input Voltage: 85 - 264 VAC
120-300 VDC
of Outputs: Up to 21

iMP™



Rev. 1.30.06
iMP Series
1 of 8

Special Features

- Full Medical EN60601 Approval
- Intelligent I²C Control
- Configurable Current Share on all outputs >10A
- Voltage adjustment on all outputs (Manual or I²C)
- Configurable Input and Output OK signals and indicators
- Configurable Inhibit/Enable
- Configurable Output UP/DOWN sequencing
- Intelligent fan (speed control/fault status)
- Customer Provided Air Option
- μ P Controlled PFC input with active Inrush protection
- I²C monitor of Voltage, Current, and Temp
- IPMI Compliant
- Programmable Voltage, Current Limit, Inhibit/Enable through I²C
- Optional Extended Hold-up Module (Semi F47 compliance)
- Power density increased by 50%
- Backward compatibility with standard MP
- External switching frequency sync input
- Optional Conformal Coating
- Industrial Temp Range
- No preload required

Electrical Specifications

Input

Input range	85-264 VAC; 120-350 VDC (Limited to 300VDC in medical applications)
Frequency	47-440 Hz
Inrush current	40A peak max. (soft start)
Efficiency	up to 85% @ full case load
Power Factor	0.99 typ. meets EN61000-3-2
Turn-on time	AC on 1.5 sec typ., Inhibit / Enable 150 ms typ. Programmable
EMI Filter	CISPR 22 / EN55022 Level "B"
Leakage current	300 μ A max. @ 240 VAC; 47-63Hz
Radiated EMI	CISPR 22 / EN55022 Level "B"
Holdover storage	20 ms minimum (independent of input VAC) additional 34mSEC holdover storage with optional HUP module (Semi F47 compatible)
AC OK	>5 ms early warning min. before outputs lose regulation. Programmable. Full cycle ride thru (50 Hz)
Harmonic distortion	Meets EN61000-3-2
Isolation	Meets EN60950 and EN60601
Global Inhibit/Enable	TTL, Logic "1" and Logic "0". Configurable.
Input fuse (internal)	iMP4: 10A; iMP8: 20A; iMP1: 20A (both lines fused)
Warranty	2 years



Output

Adjustment range*	±10% minimum all outputs (manual) (full module adjustment range using I ² C)
Margining	±4-6% nominal analog (single output module only)
Overall reg	0.4% or 20 mV max. (36W modules 4% max.)
Ripple	RMS: 0.1% or 10 mV, whichever is greater Pk-Pk: 1.0% or 50 mV, whichever is greater Bandwidth limited to 20 MHz
Dynamic response	<2% or 100 mV, with 25% load step
Recovery time	To within 1% in <300 µsec.
Overcurrent protection*	Configurable through I ² C. Single output module and main output of the dual output module 105-120% of rated output current. Aux output of dual output module 105-140% of rated output current Triple output module internally protected
Short circuit protection	Protected for continuous short circuit Recovery is automatic upon removal of short
Overvoltage protection*	Configurable through I ² C
Single output module	2-5.5V 122-134% ; 6-60V 110-120%
Dual output module	2-6V 122-134% ; 8-28V 110-120%
Triple output module	No overvoltage protection provided
Reverse voltage protection	100% of rated output current
Thermal protection*	Configurable through I ² C All outputs disabled when internal temp exceeds safe operating range. >5 ms warning (AC OK signal) before shutdown
Remote sense	Up to 0.5 V total drop (not available on triple output module)
Singlewire parallel	Configurable through firmware Current share to within 2% of total rated current
DC OK*	+/-5% of nominal. Configurable through I ² C
Minimum load	Not required
Housekeeping bias voltage	5 VDC @1.0Amp max. present whenever AC input is applied
Module inhibit*	Configured and controlled through I ² C
Switching frequency	250 kHz accepts external sync signal
Output/Output isolation	>1 Megohm, 500V
VME signal*	DC OK signal programmable through I ² C to function as POR signal

*Can be controlled via I²C

Environmental Specifications

Operating temperature	-40° to 70°C ambient. Derate each output 2.5% per degree from 50° to 70°C. (-20°C start up)
Storage temperature	-40°C to +85°C
Electromagnetic susceptibility	Designed to meet EN61000-4; -2, -3, -4, -5, -6, -8, -11 Level 3
Humidity	Operating; non-condensing 10% to 95% RH
Vibration	IEC68-2-6 to the levels of IEC721-3-2
MTBF demonstrated	>550,000 hours at full load, 220VAC and 25°C ambient conditions

Safety

UL	UL60950/UL2601
CSA	CSA22.2 No. 234 Level 5
VDE	EN60950/EN60601
BABT	Compliance to EN 60950/EN60601 BS 7002
CB	Certificate and report
CE	Mark to LVD

Output Module Line-up

Module Code	1	2	3	4	None
Module Type	Single	Single	Single	Dual	Triple
Max output power	210W	360W	750W	144W	36W
Max output current	35A	60A	150A	10A	2A
Output voltages available*	2-60V	2-60V	2-60V	5, 12-15, 28-30V 2-6, 12-15, 28-30V	8-15V 8-28V 2-28V
Standard voltage increments	25	25	25	19	18
Remote sense	Yes	Yes	Yes	Yes	Yes
Remote margin	Yes	Yes	Yes	No	No
V-Program - I ² C Control	Yes	Yes	Yes	Yes	Yes
Active Current Share	Yes	Yes	Yes	Yes	No
Module Inhibit - I ² C Control	Yes	Yes	Yes	Yes	Yes
Module Inhibit - Analog	Yes	Yes	Yes	No	No
Over voltage / Over current protection	Yes	Yes	Yes	Yes	Yes
Minimum load required	No	No	No	No	No
Slots occupied in any iMP case	1	2	3	1	1

*Programmable

Ordering Information

PARALLEL CODES							
Slot 7	Slot 6	Slot 5	Slot 4	Slot 3	Slot 2	Slot 1	iMP4 available slots
Slot 6	Slot 5	Slot 4	Slot 3	Slot 2	Slot 1		iMP8 available slots
Slot 5	Slot 4	Slot 3	Slot 2	Slot 1			iMP1 available slots
7	6	5	4	3	2	1	
0 = no parallel							
1 = 1 & 2							
2 = 2 & 3							
3 = 3 & 4							
4 = 4 & 5							
5 = 3 & 4 & 5							
6 = 5 & 6							
7 = 4 & 5 & 6							
8 = 6 & 7							
9 = 3 & 4, 6 & 7							

Output Module Voltage/Current

Voltage	Voltage Code	Single Output Module Code			Dual Output		Triple Output			PC Adjustment Ranges
		1	2	3	V1	V2	V1	V2	V3	
2V	A	35A	60A	150A	—	10A	—	—	2A	1.8 - 6.1
2.2V	B	35A	60A	150A	—	10A	—	—	2A	
3V	C	35A	60A	150A	—	10A	—	—	2A	
3.3V	D	35A	60A	150A	—	10A	—	—	2A	
5V	E	35A	60A	150A	10A	10A	—	—	2A	
5.2V	F	35A	60A	150A	—	10A	—	—	2A	
5.5V	G	34A	58A	137A	—	10A	—	—	2A	
6.0V	H	23A	42A	80A	—	10A	—	—	2A	5.4 - 13.2
8.0V	I	20A	36A	80A	—	—	1A	1A	1A	
10V	J	18A	32A	75A	—	—	1A	1A	1A	
11V	K	17A	31A	68A	—	—	1A	1A	1A	
12V	L	17A	30A	62.5A	10A	4A	1A	1A	1A	
14V	M	14A	21A	53.5A	9A	4A	1A	1A	1A	12.6 - 22.0
15V	N	14A	20A	50A	8A	4A	1A	1A	1A	
18V	O	11A	19A	41.6A	—	—	—	0.5A	0.5A	
20V	P	10.5A	18A	37.5A	—	—	—	0.5A	0.5A	
24V	Q	8.5A	15A	31.3A	4A	2A	—	0.5A	0.5A	21.6 - 39.6
28V	R	6.7A	12.8A	26.8A	3A	2A	—	0.5A	0.5A	
30V	S	6.5A	12A	25A	—	—	—	—	—	
33V	T	6.2A	11A	22.7A	—	—	—	—	—	
36V	U	5.8A	10A	20.8A	—	—	—	—	—	37.8 - 60.0
42V	V	4.2A	7.5A	17.9A	—	—	—	—	—	
48V	W	4.0A	7.5A	15.6A	—	—	—	—	—	
54V	X	3.7A	6.0A	13.9A	—	—	—	—	—	
60V	Y	3.5A	6.0A	12.5A	—	—	—	—	—	
Non-std*	Z	Special Voltage - Consult Factory for specifications								

* Note: Increments of current not shown can be achieved by paralleling modules (add currents of each module selected).

Case Size	Module/Voltage/Option Codes	Case Option Codes	Software Code	Hardware Code
iMP1*	3L0 - 2E2 - 1Q1 - 4LL0	00	A	###
<p>Case Size (mm) 4 = 2.5" x 5" x 10"; 750W - 1100W, 5 Slots (63.5 x 127 x 254) 8 = 2.5" x 7" x 10"; 1000W - 1200W, 6 Slots (63.5 x 177.8 x 254) 1 = 2.5" x 8" x 11"; 1200W - 1500W, 7 Slots (63.5 x 203.2 x 279.4)</p> <p>* Note: Add "-E" after iMP4 to denote IEC input option. eg. iMP4-E-... (Not available on iMP8 or iMP1.)</p>	<p>Module Codes Module/Voltage/Option Codes Module Codes: (None) = 36W Triple O/P (1 slot) 1 = 210W Single O/P (1 slot) 2 = 360W Single O/P (2 slot) 3 = 750W Single O/P (3 slot) 4 = 144W Dual O/P (1 slot) 5 - 9 = Future</p> <p>Voltage Codes: See Output Module Voltage/Current table above</p> <p>Option Codes: 0 = Standard 1 = Module Enable 2 = Constant Current 3 - 9 = Future</p>	<p>Case Option Codes First Digit 0 - 9 = Parallel Code</p> <p>Second Digit 0 = No Options 1 = Reverse Air 2 = Extended Hold Up (1 slot)* 3 = Global Enable 4 = Fan Off w/Inhibit 5 = Opt 1 + Opt 3 6 = Opt 1 + Opt 4 7 = Opt 3 + Opt 4 8 = Opt 1 +3 +4 9 = Future *Meets Semi F47</p>	<p>Factory Assigned for Modified Standards Standard is "A" - Software Code "Blank" - Hardware Code</p>	

Drawings

iMP Modules

DC-DC Converter Output Modules

Control Signal Information, J1 Control Connector

Pin No.	Function	
1	+ Remote Sense	single or dual o/p main
2	Remote Margin / V. Program	single o/p
3	Margin High	single o/p
4	- Remote Sense / Margin Low	single or dual o/p main
5	Spare	
6	Module, Isolated Inhibit	single or dual o/p
7	Module Inhibit return	single or dual o/p
8	Current Share (SWP)	single or dual o/p main
9	+ Remote Sense V2	dual o/p, single is spare
10	- Remote Sense V2	dual o/p, single is spare

*Note: All iMP modules have a green DCOK LED.

Single 360 Watt

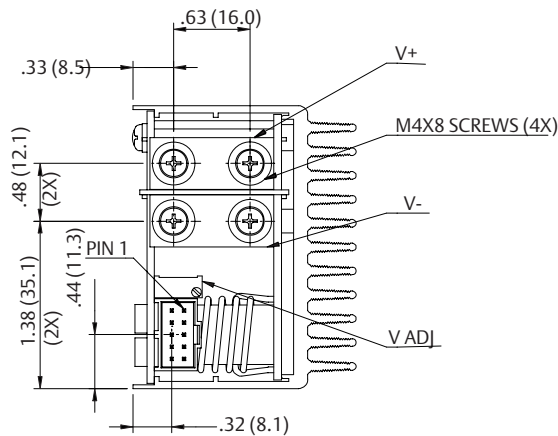

Dual 144 Watt

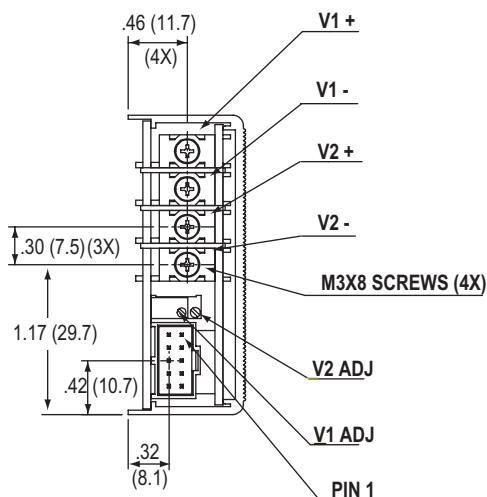

Single 210 Watt

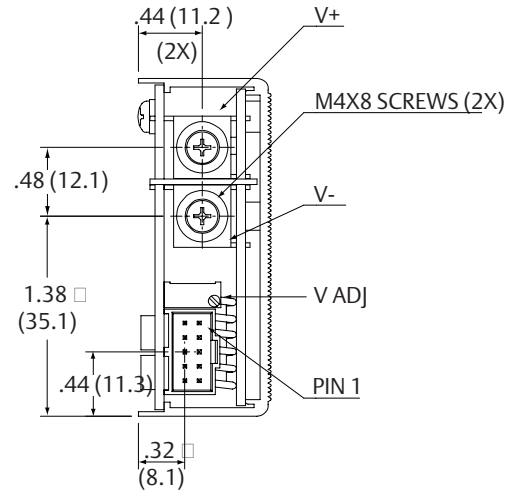

Single 250 Watt

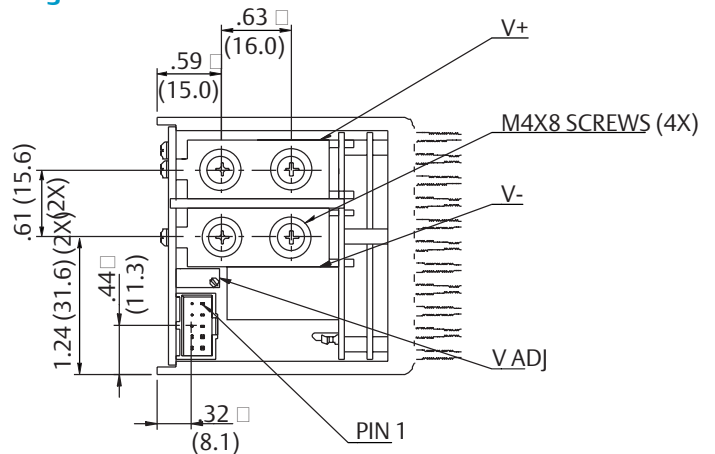

Triple 36 Watt

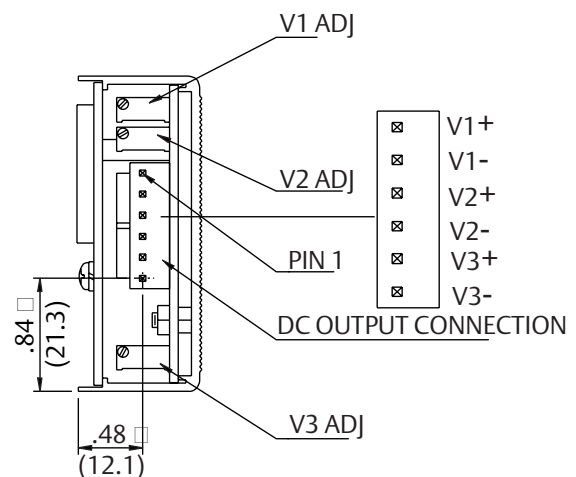

iMP Series
iMP4 (750/1100 Watts Max)

5-Inch Case Size: iMP4: 2.5" x 5" x 10" (63.5mm x 127mm x 254mm)
Weight: iMP4 Case: 2.6 lbs. • 36 W Triple: 0.5 lb. 210 W Single: 0.6 lb.
• 360 W Single 1.0 lb. • 600 W Single: 2.0 lbs. 144 W Dual: 0.6 lb.

Rev. 1.30.06
iMP Series
5 of 8

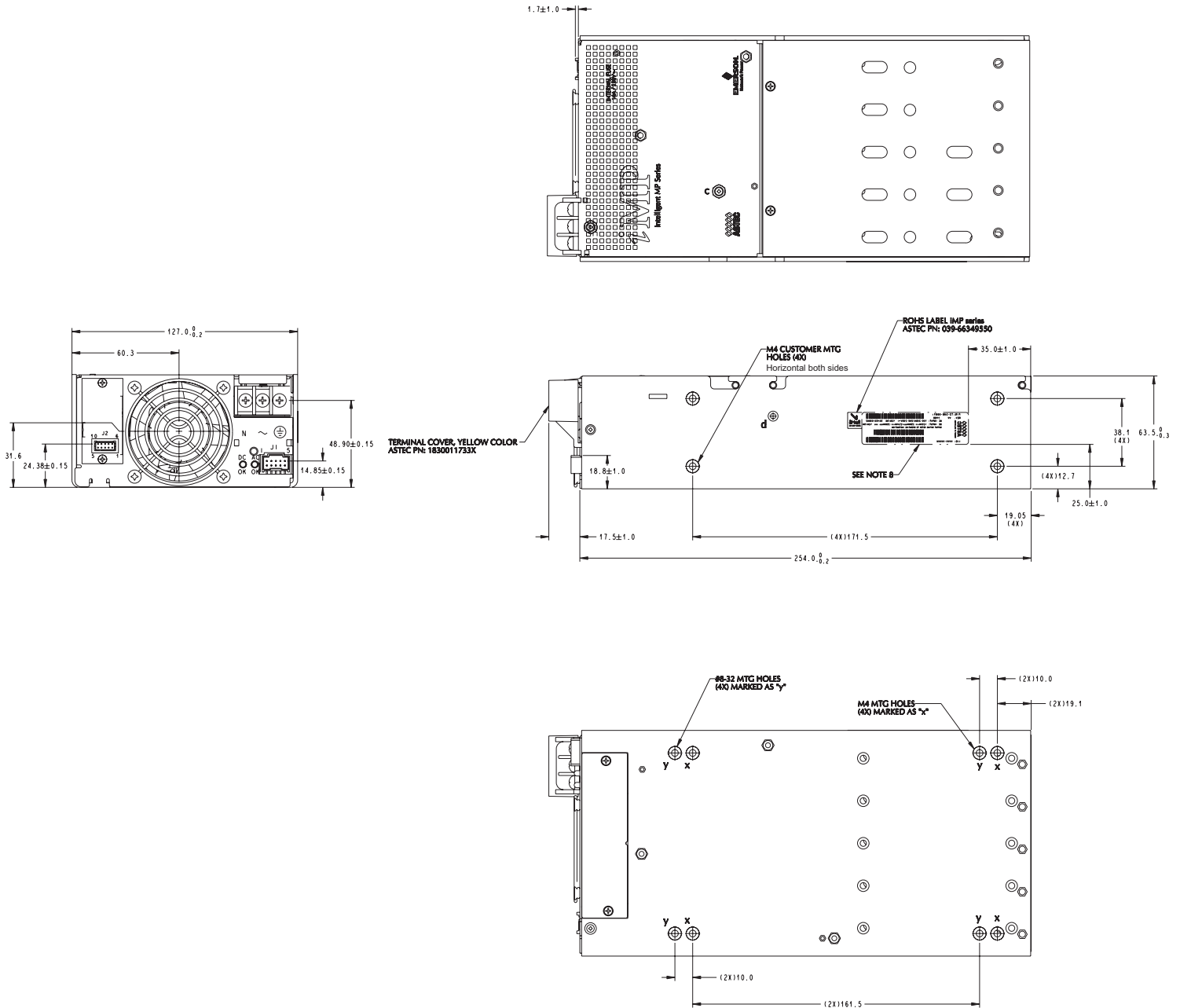

Notes

1. Input: Barrier type. Three No. 6-32 B.H. screws (0.375" centers). Max torque: 6 in-lbs. (0.67 N-m).
2. Control connectors: (J1) 10 position housing, gold plated contacts. Mates with Molex 90142-0010 housing with 90119-2110 crimp contacts (Molex C-Grid III Series) or AMP Model number 87977-3 with 87309-8 pins. Connector kit includes mating connector and 10 pins, Astec part #70-841-004. J2 10 position housing (Landwin 2051P1000T). Mates with housing 205051000 (Landwin) with 2053T011P (Landwin) pins.
3. Chassis material: aluminum with chemical film coating (conductive).
4. All dimensions are in millimeters and inches, and are typical.
5. Customer mounting -3 sides M4, bottom also includes 8-32 mounting holes. Max. penetration is 0.150" (3.8mm). Max. torque: 5in-lbs.
6. Output module connections: All single O/P modules are M4 x 8mm screws. Max. torque: 10in-lbs. Dual O/P module is M3 x 8mm screws. Max. torque: 5 in-lbs. Triple O/P module is .045" square pins on .156" centers. Mates with Molex 09-50-8063 or equivalent.

iMP Series
iMP8 (1000/1200 Watts Max)

7-Inch Case Size: iMP8: 2.5" x 7" x 10" (63.5mm x 177.8mm x 254mm)
Weight: iMP8 Case: 4.1 lbs. • 36 W Triple: 0.5 lb. • 210 W Single: 0.6 lb.
• 360 W Single: 1.0 lb. • 600 W Single: 2.0 lbs. 144 W Dual: 0.6 lb.

Rev. 1.30.06
iMP Series
6 of 8

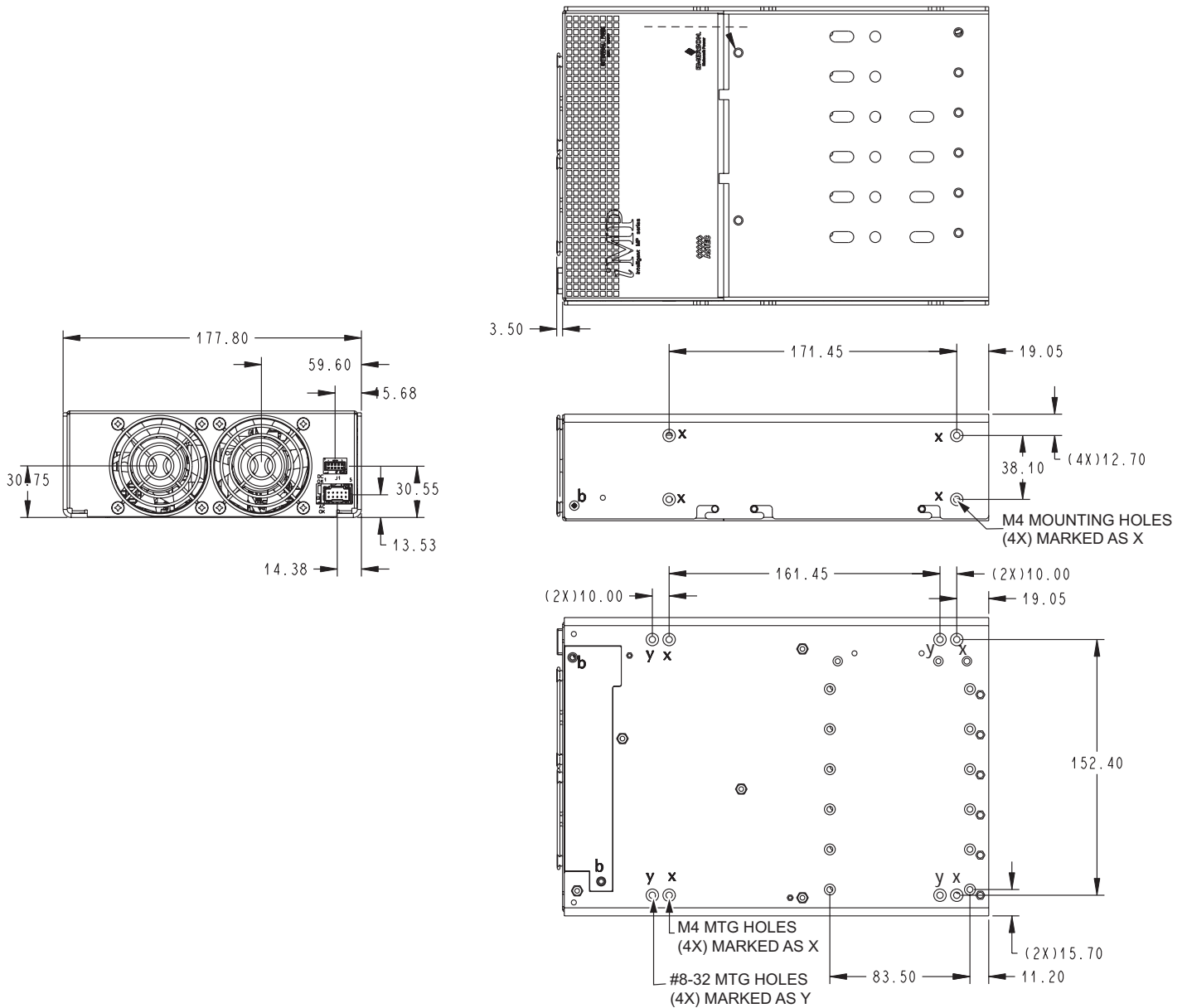

Notes

1. Input: Barrier type. Three No. 6-32 B.H. screws (0.375" centers). Max torque: 6 in-lbs. (0.67 N-m).
2. Control connectors: (J1) 10 position housing, gold plated contacts. Mates with Molex 90142-0010 housing with 90119-2110 crimp contacts (Molex C - Grid III Series) or AMP Model number 87977-3 with 87309-8 pins. Connector kit includes mating connector and 10 pins, Astec part #70-841-004. J2 10 position housing (Landwin 2051P1000T). Mates with housing 205051000 (Landwin) with 2053T011P (Landwin) pins.
3. Chassis material: aluminum with chemical film coating (conductive).
4. All dimensions are in millimeters and inches, and are typical.
5. Customer mounting -3 sides M4, bottom also includes 8-32 mounting holes. Max. penetration is 0.150" (3.8mm). Max. torque: 5in-lbs.
6. Output module connections: All single O/P modules are M4 x 8mm screws. Max. torque: 10in-lbs.
Dual O/P module is M3 x 8mm screws. Max. torque: 5 in-lbs.
Triple O/P module is .045" square pins on .156 centers. Mates with Molex 09-50-8063 or equivalent.

iMP Series
iMP1 (1200/1500 Watts Max)

8-Inch Case Size: iMP1: 2.5" x 8" x 11" (63.5mm x 203.2mm x 279.4mm)
Weight: iMP1 Case: 5.0 lbs. • 36 W Triple: 0.5 lbs. • 210 W Single: 0.6 lbs.
• 360 W Single: 1.0 lb. • 600 W Single: 2.0 lbs. 144 W Dual: 0.6 lb.

Rev. 1.30.06
iMP Series
7 of 8

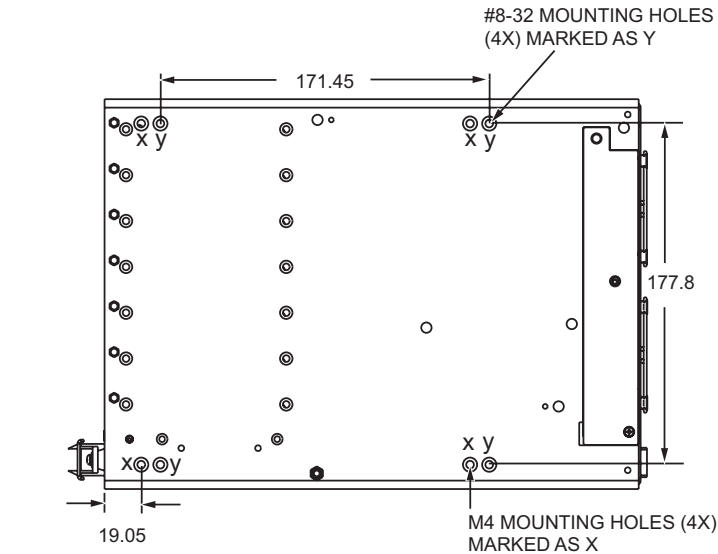
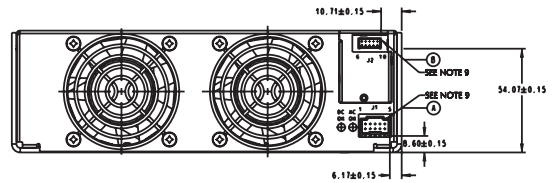
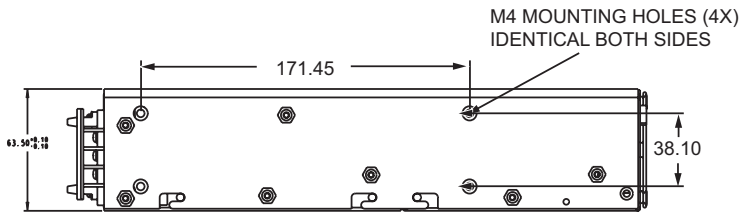
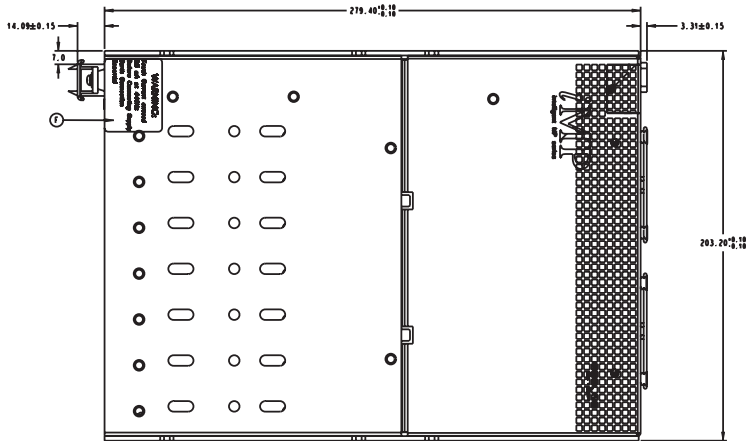

Notes

1. Input: Barrier type. Three No. 6-32 B.H. screws (0.375" centers). Max torque: 6 in-lbs (0.67 N-m).
2. Control connectors: (J1) 10 position housing, gold plated contacts. Mates with Molex 90142-0010 housing with 90119-2110 crimp contacts (Molex C-Grid III Series) or AMP Model number 87977-3 with 87309-8 pins. Connector kit includes mating connector and 10 pins, Astec part #70-841-004. J2 10 position housing (Landwin 2051P1000T). Mates with housing 205051000 (Landwin) with 2053T011P (Landwin) pins.
3. Chassis material: aluminum with chemical film coating (conductive).
4. All dimensions are in millimeters and inches, and are typical.
5. Customer mounting -3 sides M4, bottom also includes 8-32 mounting holes. Max. penetration is 0.150" (3.8mm). Max. torque: 5in-lbs.
6. Output module connections: All single O/P modules are M4 x 8mm screws. Max. torque: 10in-lbs.
Dual O/P module is M3 x 8mm screws. Max. torque: 5 in-lbs.
Triple O/P module is .045" square pins on .156 centers. Mates with Molex 09-50-8063 or equivalent.

iMP Case Specifications

iMP4

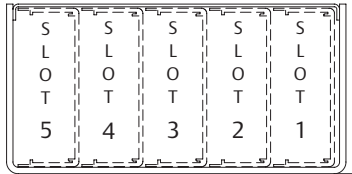

iMP4 = 2.5" x 5" x 10" 5 available slots
(63.5 x 127 x 254)

Input	
90-264VAC	180-264VAC
750W max.	1100W max.

iMP8 and iMP1

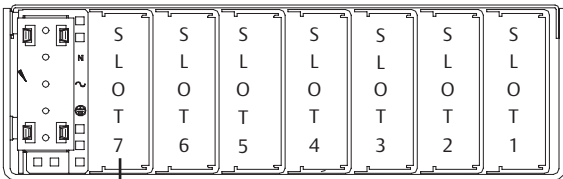

iMP8 = 2.5" x 7" x 10" 6 available slots
(63.5 x 177.8 x 254)

Input	
85-264VAC	180-264VAC
1000W max.	1200W max.

iMP1 = 2.5" x 8" x 11" 7 available slots
(63.5 x 203.2 x 279.4)

1200W max.	1500W max.
------------	------------

Astec Power

5810 Van Allen Way
Carlsbad, CA 92008
USA
Telephone: +1 760 930 4600
Facsimile: +1 760 930 0698
Technical Support: +1 888 41 ASTEC
or +1 407 241 2752

Waterfront Business Park
Merry Hill, Dudley
West Midlands, DY5 1LX
United Kingdom
Telephone: +44 (0) 1384 842 211
Facsimile: +44 (0) 1384 843 355

Units 2111-2116, Level 21
Tower 1, Metroplaza
223, Hing Fong Road
Kwai Fong, New Territories
Hong Kong
Telephone: +852 2437 9662
Facsimile: +852 2402 4426

For global contact, visit:
www.astecpower.com
technicalsupport@astec.com

While every precaution has been taken to ensure accuracy and completeness in this literature, Astec Power assumes no responsibility, and disclaims all liability for damages resulting from use of this information or for any errors or omissions.

Printed in USA
01.06

Emerson Network Power.
The global leader in enabling
business-critical continuity.

- AC Power
- Connectivity
- DC Power
- **Embedded Power**
- Inbound Power
- Integrated Cabinet Solutions
- Outside Plant
- Precision Cooling
- Site Monitoring and Services

EmersonNetworkPower.com

Emerson Network Power and the Emerson Network Power logo are trademarks and service marks of Emerson Electric Co.
©2006 Emerson Electric Co.

Pin Connectors

Figure 1. AC Input

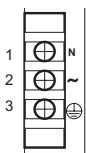

AC Input

Pin No.	Function
1	AC Neutral
2	AC Line (Hot)
3	Chassis (Earth) Ground

Figure 2. Connector J1

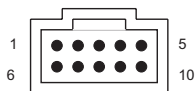

Mates with
Molex 90142-0010
Amp 87977-3

PFC Input Connector (control and signals)

Pin No.	Function
1	Input AC OK - "Emitter"
2	Input AC OK - "Collector"
3	Global DC OK - "Emitter"
4	Global DC OK - "Collector"
5	External Sync
6	Global Inhibit / Optional Enable Logic "0"
7	Global Inhibit / Optional Enable Logic "1"
8	Global Inhibit / Optional Enable Return
9	+5VSB Housekeeping
10	+5VSB Housekeeping Return

Figure 3. Connector J2

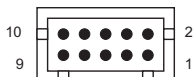

Mates with
Landwin 2050S/000 Housing
2053T011P Pin

I²C Bus Output Connector

Pin No.	Function
1	5VCC External Bus
2	Serial Data Signal
3	Secondary Return
4	Serial Clock Signal
5	Address Bit 2
6	Address Bit 1
7	Address Bit 0
8	No connection