

NC7SZ57 • NC7SZ58

TinyLogic™ UHS Universal Configurable 2-Input Logic Gates

General Description

The NC7SZ57 and the NC7SZ58 are Universal Configurable 2-Input Logic Gates. Each device is capable of being configured for 1 of 5 unique 2-input logic functions. Any possible 2-input combinatorial logic function can be implemented as shown in the Function Selection Table. Device functionality is selected by how the device is wired at the board level. Figure 1 through Figure 10 illustrate how to connect the NC7SZ57 and NC7SZ58 respectively for the desired logic function. All inputs have been implemented with hysteresis.

The device is fabricated with advanced CMOS technology to achieve ultra high speed with high output drive while maintaining low static power dissipation over a broad V_{CC} operating range. The device is specified to operate over the 1.65V to 5.5V V_{CC} operating range. The input and output are high impedance when V_{CC} is 0V. Inputs tolerate voltages up to 5.5V independent of V_{CC} operating range.

Features

- Space saving SC70-6 lead surface mount package
- Ultra small MicroPak™ leadless package
- Ultra High Speed
- Capable of implementing any 2-input logic function
- Typical usage replaces 2 TinyLogic gate devices
- Reduces part counts in inventory
- Broad V_{CC} operating range: 1.65V to 5.5V
- Power down high impedance input/output
- Overvoltage tolerant inputs facilitate 5V to 3V translation
- Patented noise/EMI reduction circuitry implemented

Ordering Code:

Order Number	Package Number	Product Code Top Mark	Package Description	Supplied As
NC7SZ57P6X	MAA06A	Z57	6-Lead SC70, EIAJ SC88, 1.25mm Wide	3k Units on Tape and Reel
NC7SZ58P6X	MAA06A	Z58	6-Lead SC70, EIAJ SC88, 1.25mm Wide	3k Units on Tape and Reel
NC7SZ57L6X	MAC06A	KK	6-Lead MicroPak, 1.0mm Wide	5k Units on Tape and Reel
NC7SZ58L6X	MAC06A	LL	6-Lead MicroPak, 1.0mm Wide	5k Units on Tape and Reel

TinyLogic™ is a trademark of Fairchild Semiconductor Corporation.

NC7SZ57 • NC7SZ58 TinyLogic™ UHS Universal Configurable 2-Input Logic Gates

Pin Descriptions

Pin Name	Description
I ₀ , I ₁ , I ₂	Data Inputs
Y	Output

Function Table

Inputs			NC7SZ57	NC7SZ58
I ₂	I ₁	I ₀	$Y = (I_0) \cdot (I_2) + (I_1) \cdot (I_2)$	$Y = (I_0) \cdot (I_2) + (I_1) \cdot (I_2)$
L	L	L	H	L
L	L	H	L	H
L	H	L	H	L
L	H	H	L	H
H	L	L	L	H
H	L	H	L	H
H	H	L	H	L
H	H	H	H	L

H = HIGH Logic Level L = LOW Logic Level

Connection Diagrams

Pin Assignments for SC70

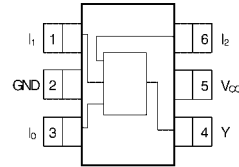

(Top View)
NC7SZ57 and NC7SZ58

Pin One Orientation Diagram

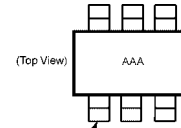

Pin One

AAA = Product Code Top Mark - see ordering code

Note: Orientation of Top Mark determines Pin One location. Read the top product code mark left to right, Pin One is the lower left pin (see diagram).

Pad Assignment for MicroPak

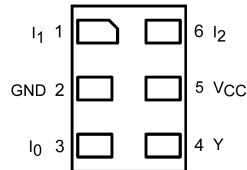

(Top Thru View)

Function Selection Table

2-Input Logic Function	Device Selection	Connection Configuration
2-Input AND	NC7SZ57	Figure 1
2-Input AND with inverted input	NC7SZ58	Figures 7, 8
2-Input AND with both inputs inverted	NC7SZ57	Figure 4
2-Input NAND	NC7SZ58	Figure 6
2-Input NAND with inverted input	NC7SZ57	Figures 2, 3
2-Input NAND with both inputs inverted	NC7SZ58	Figure 9
2-Input OR	NC7SZ58	Figure 9
2-Input OR with inverted input	NC7SZ57	Figures 2, 3
2-Input OR with both inputs inverted	NC7SZ58	Figure 6
2-Input NOR	NC7SZ57	Figure 4
2-Input NOR with inverted input	NC7SZ58	Figures 7, 8
2-Input NOR with both inputs inverted	NC7SZ57	Figure 1
2-Input XOR	NC7SZ58	Figure 10
2-Input XNOR	NC7SZ57	Figure 5

Logic Configurations NC7SZ57

Figure 1 through Figure 5 show the logical functions that can be implemented using the NC7SZ57. The diagrams show the DeMorgan's equivalent logic duals for a given 2-input function. Next to the logical implementation is the board level physical implementation of how the pins of the function should be connected.

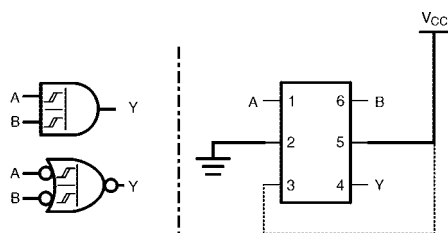

FIGURE 1. 2-Input AND Gate

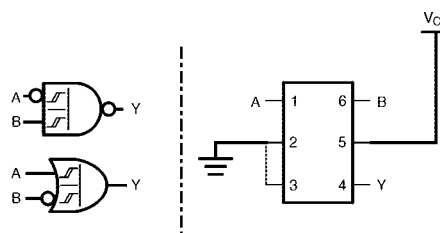

FIGURE 2. 2-Input NAND with Inverted A Input

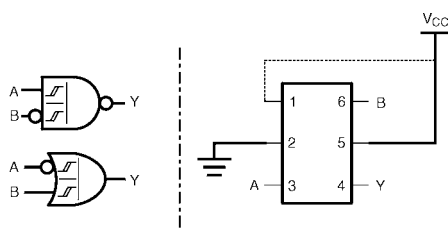

FIGURE 3. 2-Input NAND with Inverted B Input

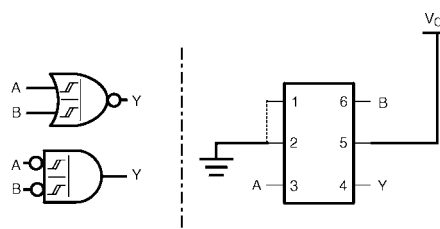

FIGURE 4. 2-Input NOR Gate

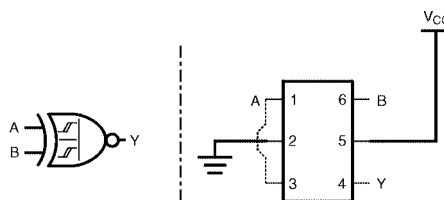

FIGURE 5. 2-Input XNOR Gate

Logic Configurations NC7SZ58

Figure 6 through Figure 10 show the logical functions that can be implemented using the NC7SZ58. The diagrams show the DeMorgan's equivalent logic duals for a given 2-input function. Next to the logical implementation is the board level physical implementation of how the pins of the function should be connected.

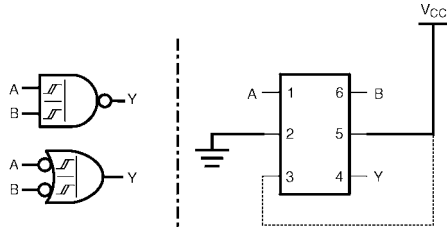

FIGURE 6. 2-Input NAND Gate

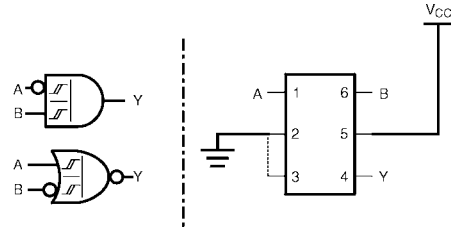

FIGURE 7. 2-Input AND with Inverted A Input

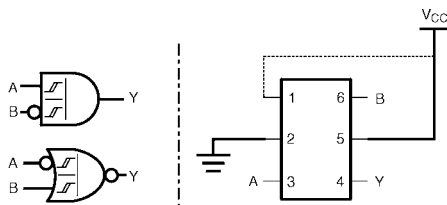

FIGURE 8. 2-Input AND with Inverted B Input

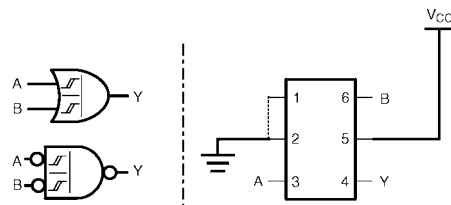

FIGURE 9. 2-Input OR Gate

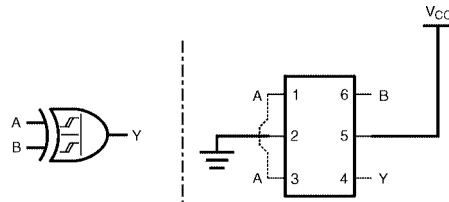

FIGURE 10. 2-Input XOR Gate

Absolute Maximum Ratings ^(Note 1)		Recommended Operating Conditions	
Supply Voltage (V_{CC})	-0.5V to +7.0V	Supply Voltage Operating (V_{CC})	1.65V to 5.5V
DC Input Voltage (V_{IN})	-0.5V to +7.0V	Supply Voltage Data Retention (V_{CC})	1.5V to 5.5V
DC Output Voltage (V_{OUT})	-0.5V to +7.0V	Input Voltage (V_{IN})	0V to 5.5V
DC Input Diode Current (I_{IK})		Output Voltage (V_{OUT})	0V to V_{CC}
@ $V_{IN} \leq 0.5V$	-50 mA	Operating Temperature (T_A)	-40°C to +85°C
DC Output Diode Current (I_{OK})		Thermal Resistance (θ_{JA})	
@ $V_{IN} \leq -0.5V$	-50 mA	SC70-6	350°C/W
DC Output Source/Sink Current (I_{OUT})	± 50 mA	Note 1: Absolute maximum ratings are DC values beyond which the device may be damaged or have its useful life impaired. The datasheet specifications should be met, without exception, to ensure that the system design is reliable over its power supply, temperature, and output/input loading variables. Fairchild does not recommend operation outside datasheet specifications.	
DC V_{CC} or Ground Current (I_{CC} / I_{GND})	± 50 mA		
Storage Temperature Range (T_{STG})	-65°C to +150°C		
Max Junction Temperature under Bias (T_J)	150°C		
Lead Temperature (T_L)			
(Soldering, 10 seconds)	260°C		
Power Dissipation (P_D) @ +85°C			
SC70-6	180 mW		

DC Electrical Characteristics

Symbol	Parameter	V_{CC} (V)	$T_A = +25^\circ\text{C}$			$T_A = -40^\circ\text{C to } +85^\circ\text{C}$		Units	Conditions	
			Min	Typ	Max	Min	Max			
V_P	Positive Threshold Voltage	1.65	0.6	0.99	1.4	0.6	1.4	V		
		2.3	1.0	1.39	1.8	1.0	1.8			
		3.0	1.3	1.77	2.2	1.3	2.2			
		4.5	1.9	2.49	3.1	1.9	3.1			
		5.5	2.2	2.95	3.6	2.2	3.6			
V_N	Negative Threshold Voltage	1.65	0.2	0.50	0.9	0.2	0.9	V		
		2.3	0.4	0.75	1.15	0.4	1.15			
		3.0	0.6	0.99	1.5	0.6	1.5			
		4.5	1.0	1.43	2.0	1.0	2.0			
		5.5	1.2	1.70	2.3	1.2	2.3			
V_H	Hysteresis Voltage	1.65	0.15	0.48	0.9	0.15	0.9	V		
		2.3	0.25	0.64	1.1	0.25	1.1			
		3.0	0.4	0.78	1.2	0.4	1.2			
		4.5	0.6	1.06	1.5	0.6	1.5			
		5.5	0.7	1.25	1.7	0.7	1.7			
V_{OH}	HIGH Level Output Voltage	1.65	1.55	1.65		1.55		V	$V_{IN} = V_{IH}$ or V_{IL}	$I_{OH} = -100 \mu\text{A}$
		2.3	2.2	2.3		2.2				
		3.0	2.9	3.0		2.9		V	$V_{IN} = V_{IH}$ or V_{IL}	$I_{OH} = -4 \text{ mA}$ $I_{OH} = -8 \text{ mA}$ $I_{OH} = -16 \text{ mA}$ $I_{OH} = -24 \text{ mA}$ $I_{OH} = -32 \text{ mA}$
		4.5	4.4	4.5		4.4				
		1.65	1.29	1.52		1.29				
		2.3	1.9	2.15		1.9				
		3.0	2.4	2.80		2.4				
		3.0	2.3	3.68		2.3				
		4.5	3.8	4.20		3.8				
		V_{OL}	LOW Level Output Voltage	1.65		0.0	0.10		0.10	V
2.3				0.0	0.10		0.10			
3.0				0.0	0.10		0.10	V	$V_{IN} = V_{IH}$ or V_{IL}	$I_{OL} = 4 \text{ mA}$ $I_{OL} = 8 \text{ mA}$ $I_{OL} = 16 \text{ mA}$ $I_{OL} = 24 \text{ mA}$ $I_{OL} = 32 \text{ mA}$
4.5				0.0	0.10		0.10			
1.65				0.08	0.24		0.24			
2.3				0.10	0.3		0.3			
3.0				0.15	0.4		0.4			
3.0				0.22	0.55		0.55			
4.5				0.22	0.55		0.55			
I_{IN}	Input Leakage Current			0-5.5		± 0.1		± 1	μA	$V_{IN} = 5.5V, \text{GND}$

DC Electrical Characteristics (Continued)										
Symbol	Parameter	V _{CC} (V)	T _A = +25°C			T _A = -40°C to +85°C		Units	Conditions	
			Min	Typ	Max	Min	Max			
I _{OFF}	Power Off Leakage Current	0.0			1		10	μA	V _{IN} or V _{OUT} = 5.5V	
I _{CC}	Quiescent Supply Current	1.65-5.5			1		10	μA	V _{IN} = 5.5V, GND	
AC Electrical Characteristics										
Symbol	Parameter	V _{CC} (V)	T _A = +25°C			T _A = -40°C to +85°C		Units	Conditions	Fig. No.
			Min	Typ	Max	Min	Max			
t _{PLH}	Propagation Delay I _n to Y	1.8 ± 0.15	3.0	8	14.0	3.0	14.5	ns	C _L = 15 pF R _L = 1 MΩ	Figures 11, 13
t _{PHL}		2.5 ± 0.2	1.5	4.9	8.0	1.5	8.5			
		3.3 ± 0.3	1.2	3.7	5.3	1.2	5.7			
		5.0 ± 0.5	0.8	2.8	4.3	0.8	4.6			
t _{PLH}	Propagation Delay I _n to Y	3.3 ± 0.3	1.5	4.2	6.0	1.5	6.5	ns	C _L = 50pF R _L = 500Ω	Figures 11, 13
t _{PHL}		5.0 ± 0.5	1.0	3.4	4.9	1.0	5.3			
C _{IN}	Input Capacitance	0		2				pF		
C _{PD}	Power Dissipation	3.3		14				pF	(Note 2)	Figure 12
	Capacitance	5.0		17						
<p>Note 2: C_{PD} is defined as the value of the internal equivalent capacitance which is derived from dynamic operating current consumption (I_{CCD}) at no output loading and operating at 50% duty cycle. (See Figure 12) C_{PD} is related to I_{CCD} dynamic operatic current by the expression: $I_{CCD} = (C_{PD})(V_{CC})(f_{in}) + (I_{CC}Static)$.</p>										

AC Loading and Waveforms

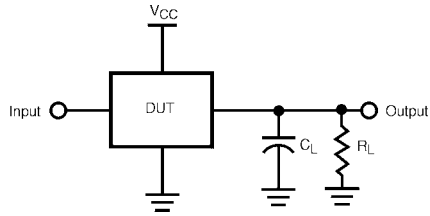

C_L includes load and stray Capacitance
 Input PRR = 1.0 MHz, t_W = 500 ns

FIGURE 11. AC Test Circuit

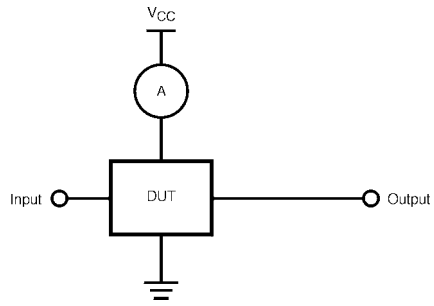

Input = AC Waveforms
 PRR = Variable; Duty Cycle = 50%

FIGURE 12. I_{CCD} Test Circuit

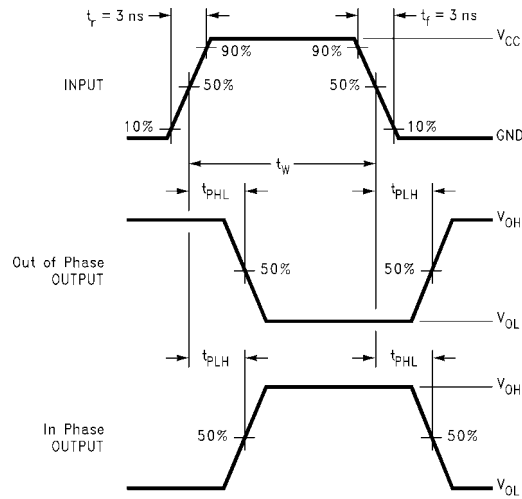

FIGURE 13. AC Waveforms

Tape and Reel Specification

TAPE FORMAT for SC70

Package Designator	Tape Section	Number Cavities	Cavity Status	Cover Tape Status
P6X	Leader (Start End)	125 (typ)	Empty	Sealed
	Carrier	3000	Filled	Sealed
	Trailer (Hub End)	75 (typ)	Empty	Sealed

TAPE DIMENSIONS inches (millimeters)

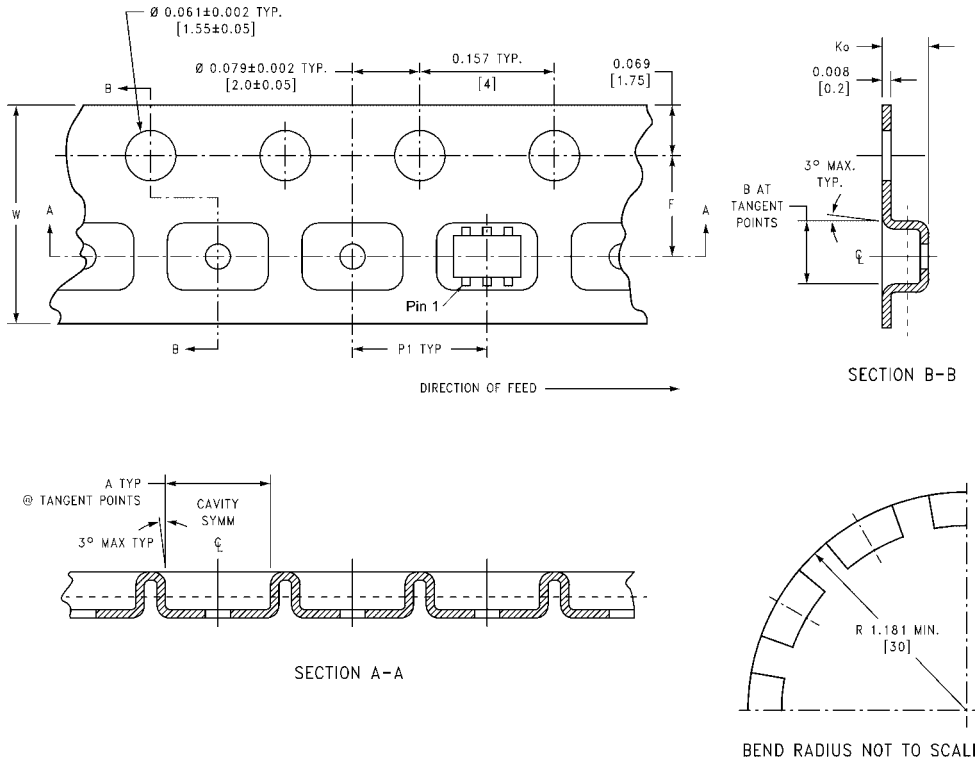

Package	Tape Size	DIM A	DIM B	DIM F	DIM K _o	DIM P1	DIM W
SC70-6	8 mm	0.093 (2.35)	0.096 (2.45)	0.138 ± 0.004 (3.5 ± 0.10)	0.053 ± 0.004 (1.35 ± 0.10)	0.157 (4)	0.315 ± 0.004 (8 ± 0.1)

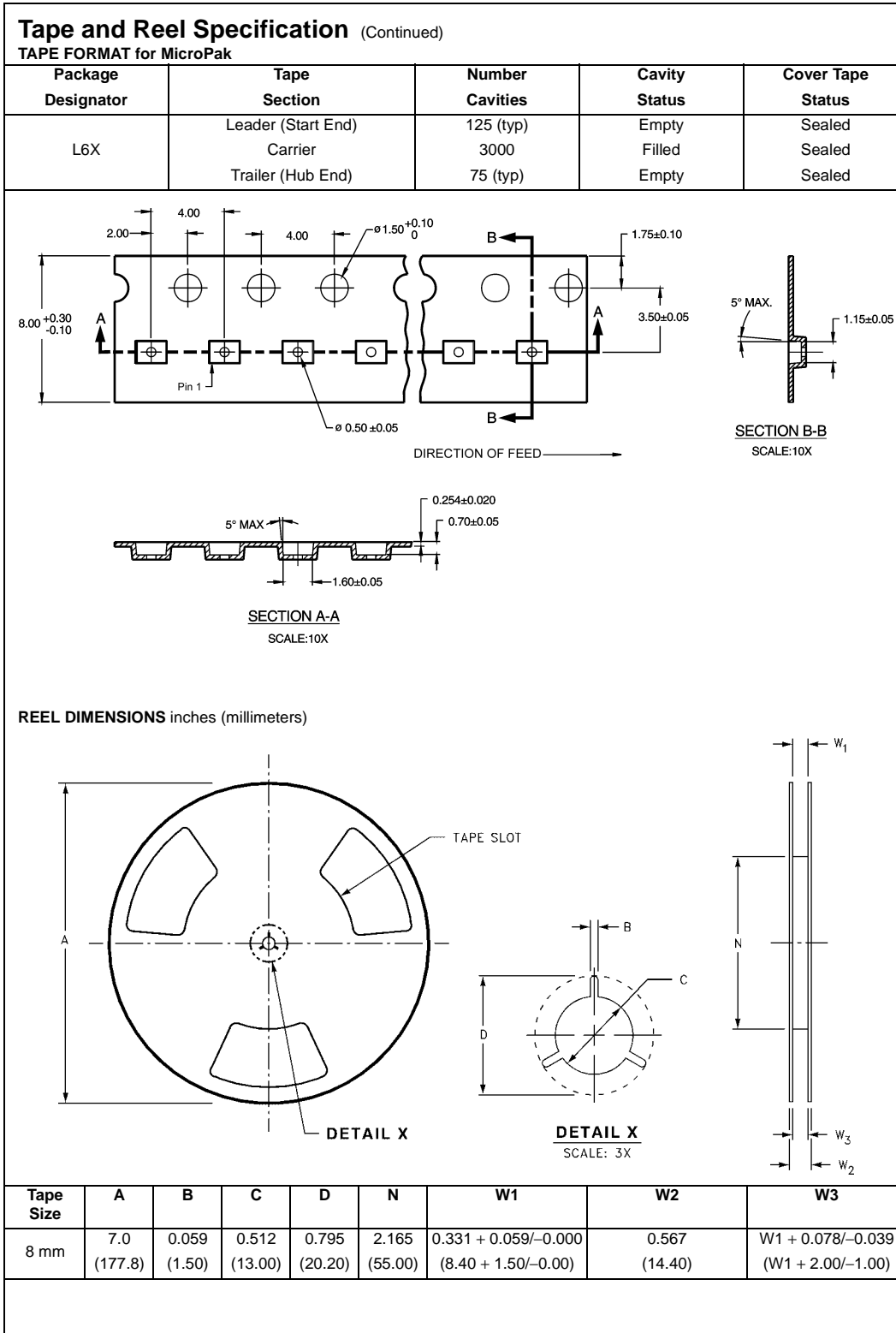

Physical Dimensions inches (millimeters) unless otherwise noted

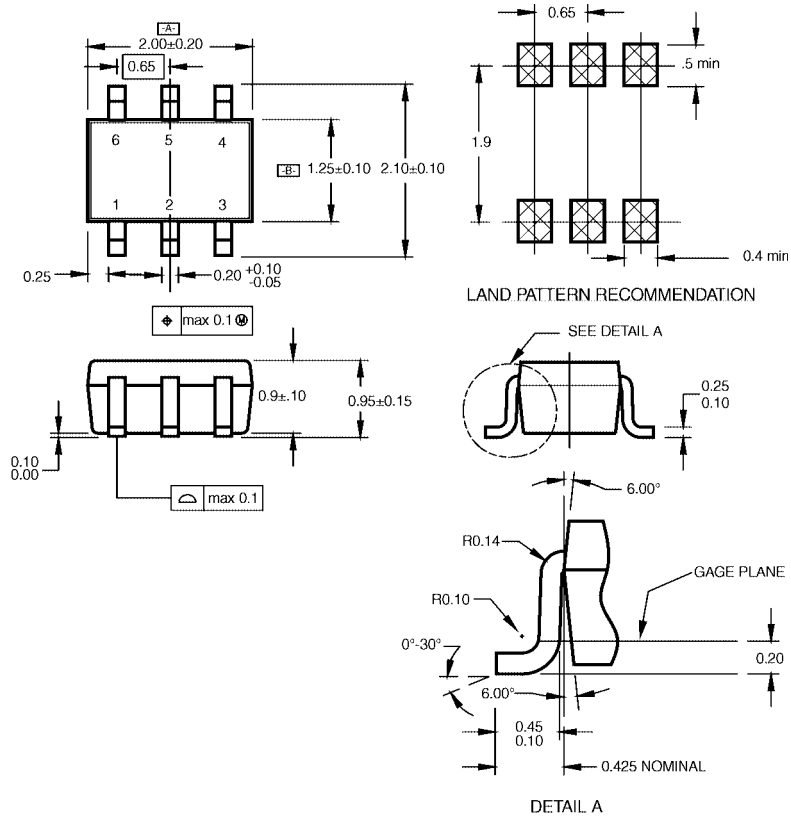

NOTES:

- A. CONFORMS TO EIAJ REGISTERED OUTLINE DRAWING SC88.
- B. DIMENSIONS DO NOT INCLUDE BURRS OR MOLD FLASH.
- C. DIMENSIONS ARE IN MILLIMETERS.

MAA06ARevC

**6-Lead SC70, EIAJ SC88, 1.25mm Wide
Package Number MAA06A**

Physical Dimensions inches (millimeters) unless otherwise noted (Continued)

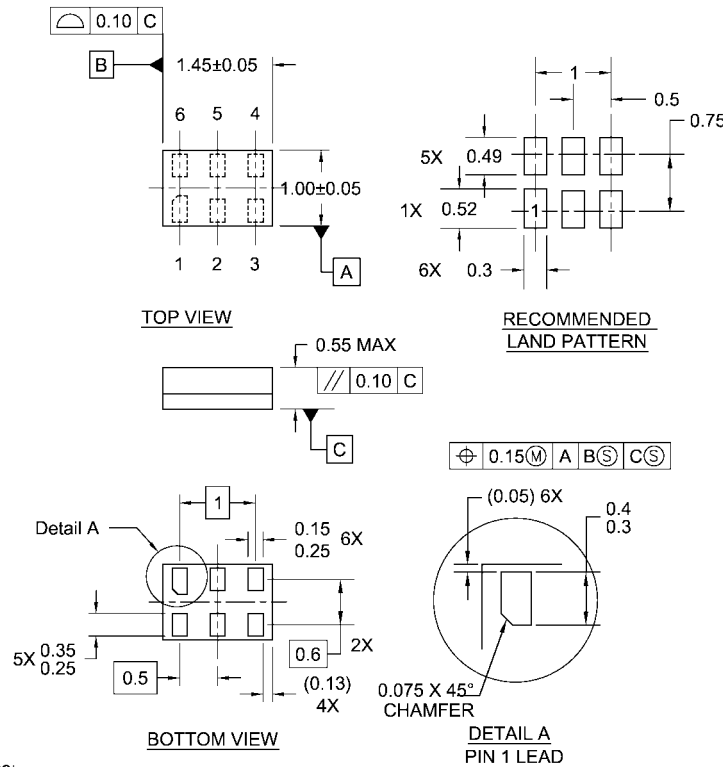

- Notes:
1. JEDEC PACKAGE REGISTRATION IS ANTICIPATED
 2. DIMENSIONS ARE IN MILLIMETERS
 3. DRAWING CONFORMS TO ASME Y14.5M-1994

MAC06ARevB

**6-Lead MicroPak, 1.0mm Wide
Package Number MAC06A**

Fairchild does not assume any responsibility for use of any circuitry described, no circuit patent licenses are implied and Fairchild reserves the right at any time without notice to change said circuitry and specifications.

LIFE SUPPORT POLICY

FAIRCHILD'S PRODUCTS ARE NOT AUTHORIZED FOR USE AS CRITICAL COMPONENTS IN LIFE SUPPORT DEVICES OR SYSTEMS WITHOUT THE EXPRESS WRITTEN APPROVAL OF THE PRESIDENT OF FAIRCHILD SEMICONDUCTOR CORPORATION. As used herein:

1. Life support devices or systems are devices or systems which, (a) are intended for surgical implant into the body, or (b) support or sustain life, and (c) whose failure to perform when properly used in accordance with instructions for use provided in the labeling, can be reasonably expected to result in a significant injury to the user.
2. A critical component in any component of a life support device or system whose failure to perform can be reasonably expected to cause the failure of the life support device or system, or to affect its safety or effectiveness.

www.fairchildsemi.com