

105 dB, 24-Bit, 192 kHz Stereo Audio ADC

A/D Features

- Multi-bit Delta Sigma modulator
- 105 dB dynamic range
- -95 dB THD+N
- Stereo 6:1 Input Multiplexer
- Programmable Gain Amplifier (PGA)
 - +/- 12 dB gain, 0.5 dB step size
 - Zero crossing, click-free transitions
- Stereo microphone inputs
 - +32 dB gain stage
 - Low noise bias supply
- Up to 192 kHz sampling rates
- Selectable serial audio interface formats
 - Left justified up to 24-bit
 - I²S up to 24-bit
- High pass filter or DC offset calibration

System Features

- Power down mode
- +3.3 V to +5 V analog power supply, nominal
- +3.3 V to +5 V digital power supply, nominal
- Direct interface with 1.8 V to 5 V logic levels
- Pin-compatible with CS4245

General Description

The CS5345 integrates an analog multiplexer, programmable gain amplifier, and stereo audio analog-to-digital converter. The CS5345 performs stereo analog-to-digital (A/D) conversion of up to 24-bit serial values at sample rates up to 192 kHz.

A 6:1 stereo input multiplexer is included for selecting between line level or microphone level inputs. The microphone input path includes a +32 dB gain stage and a low noise bias voltage supply. The PGA is available for line or microphone inputs and provides gain/attenuation of ± 12 dB in 0.5 dB steps.

The output of the PGA is followed by an advanced 5th-order, multi-bit delta sigma modulator and digital filtering/decimation. Sampled data is transmitted by the serial audio interface at rates from 4 kHz to 192 kHz in either slave or master mode.

Integrated level translators allow easy interfacing between the CS5345 and other devices operating over a wide range of logic levels.

ORDERING INFORMATION

CS5345-CQZ	-10° to 70° C	48-pin LQFP
CDB5345		Evaluation Board

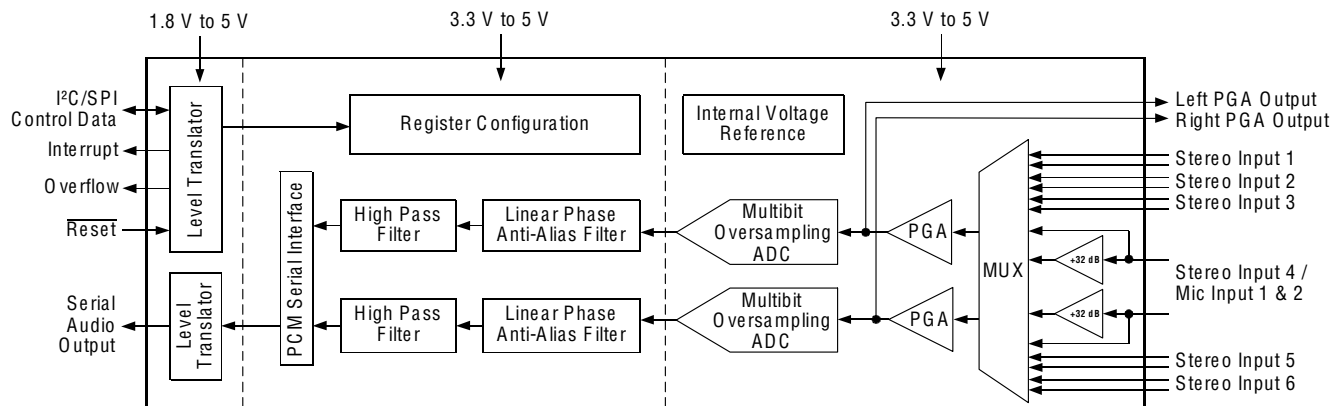

Advance Product Information

This document contains information for a new product.
Cirrus Logic reserves the right to modify this product without notice.

TABLE OF CONTENTS

1. PIN DESCRIPTIONS	3
2. CHARACTERISTICS AND SPECIFICATIONS	5
SPECIFIED OPERATING CONDITIONS	5
ABSOLUTE MAXIMUM RATINGS	5
ADC ANALOG CHARACTERISTICS	6
ADC ANALOG CHARACTERISTICS	8
ADC DIGITAL FILTER CHARACTERISTICS.....	9
PGAOUT ANALOG CHARACTERISTICS.....	10
PGAOUT ANALOG CHARACTERISTICS (CONT'D).....	11
PGAOUT ANALOG CHARACTERISTICS (CONT'D).....	12
DC ELECTRICAL CHARACTERISTICS.....	13
DIGITAL INTERFACE CHARACTERISTICS.....	14
SWITCHING CHARACTERISTICS - SERIAL AUDIO PORT	15
SWITCHING CHARACTERISTICS - CONTROL PORT - I ² C FORMAT	18
SWITCHING CHARACTERISTICS - CONTROL PORT - SPI FORMAT	19
3. TYPICAL CONNECTION DIAGRAM	20
4. APPLICATIONS	21
4.1 Recommended Power-Up Sequence	21
4.2 System Clocking	21
4.2.1 Master Clock	21
4.2.2 Master Mode	22
4.2.3 Slave Mode	22
4.3 High Pass Filter and DC Offset Calibration	22
4.4 Analog Input Multiplexer, PGA, and Mic Gain	23
4.5 Input Connections	23
4.6 PGA Auxiliary Analog Output	23
4.7 Control Port Description and Timing	24
4.7.1 SPI Mode	24
4.7.2 I ² C Mode	25
4.8 Interrupts and Overflow	27
4.9 Reset	27
4.10 Synchronization of Multiple Devices	27
4.11 Grounding and Power Supply Decoupling	27
5. REGISTER QUICK REFERENCE	28
6. REGISTER DESCRIPTION	29
6.1 Chip ID - Register 01h	29
6.2 Power Control - Address 02h	29
6.3 ADC Control - Address 04h	29
6.4 MCLK Frequency - Address 05h	30
6.5 PGAOut Control - Address 06h	31
6.6 Channel A PGA Control - Address 07h	31
6.7 Channel B PGA Control - Address 08h	31
6.8 ADC Input Control - Address 09h	32
6.9 Active Level Control - Address 0Ch	33
6.10 Interrupt Status - Address 0Dh	33
6.11 Interrupt Mask - Address 0Eh	34
6.12 Interrupt Mode MSB - Address 0Fh	34
6.13 Interrupt Mode LSB - Address 10h	34
7. PARAMETER DEFINITIONS	35
8. PACKAGE DIMENSIONS	36
9. THERMAL CHARACTERISTICS AND SPECIFICATIONS	36
Appendix A: Filter Plots	37

1. PIN DESCRIPTIONS

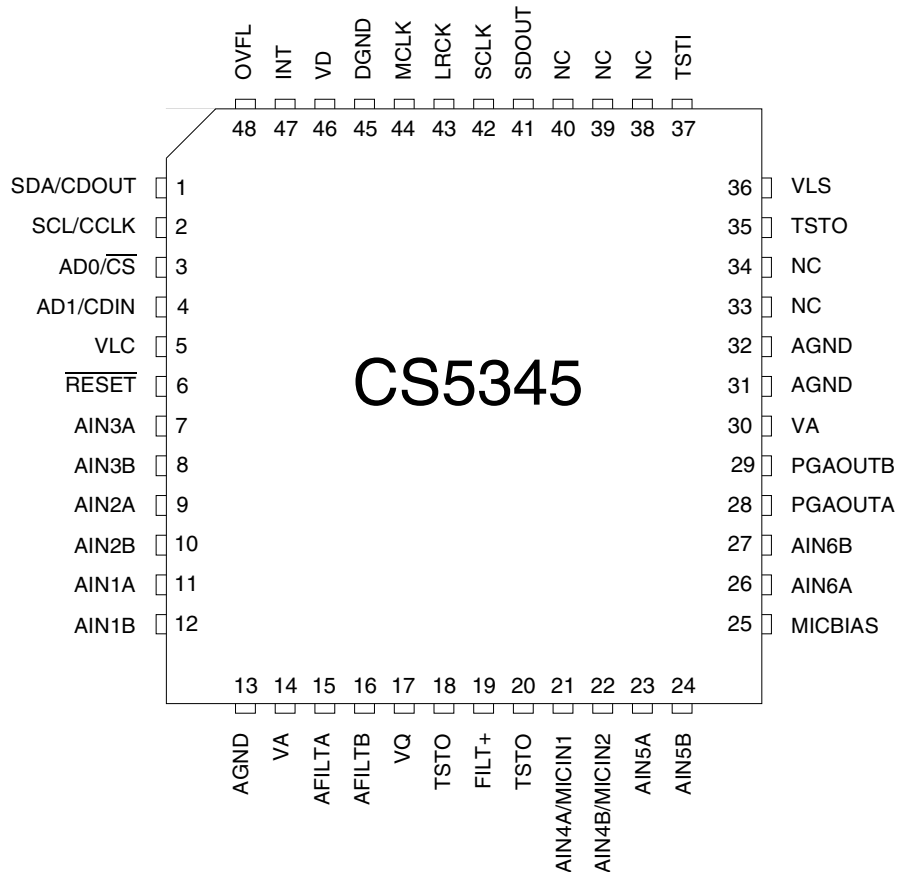

Pin Name	#	Pin Description
SDA/CDOUT	1	Serial Control Data (Input/Output) - SDA is a data I/O in I ² C mode. CDOUT is the output data line for the control port interface in SPI mode.
SCL/CCLK	2	Serial Control Port Clock (Input) - Serial clock for the serial control port.
AD0/ $\overline{\text{CS}}$	3	Address Bit 0 (I²C) / Control Port Chip Select (SPI) (Input) - AD0 is a chip address pin in I ² C mode; $\overline{\text{CS}}$ is the chip select signal for SPI format.
AD1/CDIN	4	Address Bit 1 (I²C) / Serial Control Data Input (SPI) (Input) - AD1 is a chip address pin in I ² C mode; CDIN is the input data line for the control port interface in SPI mode.
VLC	5	Control Port Power (Input) - Determines the required signal level for the control port interface. Refer to the Recommended Operating Conditions for appropriate voltages.
$\overline{\text{RESET}}$	6	Reset (Input) - The device enters a low power mode when this pin is driven low.
AIN3A AIN3B	7, 8	Stereo Analog Input 3 (Input) - The full scale level is specified in the ADC Analog Characteristics specification table.
AIN2A AIN2B	9, 10	Stereo Analog Input 2 (Input) - The full scale level is specified in the ADC Analog Characteristics specification table.

AIN1A	11,	Stereo Analog Input 1 (Input) - The full scale level is specified in the ADC Analog Characteristics specification table.
AIN1B	12	
AGND	13	Analog Ground (Input) - Ground reference for the internal analog section.
VA	14	Analog Power (Input) - Positive power for the internal analog section.
AFILTA	15	Antialias Filter Connection (Output) - Antialias filter connection for the channel A ADC input.
AFILTB	16	Antialias Filter Connection (Output) - Antialias filter connection for the channel B ADC input.
VQ	17	Quiescent Voltage (Output) - Filter connection for the internal quiescent reference voltage.
TSTO	18	Test Pin (Output) - This pin must be left unconnected.
FILT+	19	Positive Voltage Reference (Output) - Positive reference voltage for the internal sampling circuits.
TSTO	20	Test Pin - This pin must be left unconnected.
AIN4A/MICIN1	21,	Stereo Analog Input 4 / Microphone Input 1 & 2 (Input) - The full scale level is specified in the ADC Analog Characteristics specification table.
AIN4B/MICIN2	22	
AIN5A	23,	Stereo Analog Input 5 (Input) - The full scale level is specified in the ADC Analog Characteristics specification table.
AIN5B	24	
MICBIAS	25	Microphone Bias Supply (Output) - Low noise bias supply for external microphone. Electrical characteristics are specified in the DC Electrical Characteristics specification table.
AIN6A	26,	Stereo Analog Input 6 (Input) - The full scale level is specified in the ADC Analog Characteristics specification table.
AIN6B	27	
PGAOUTA	28,	PGA Analog Audio Output (Output) - Either an analog output from the PGA block or high impedance. See "PGAOut Source Select (Bit 6)" on page 31.
PGAOUTB	29	
VA	30	Analog Power (Input) - Positive power for the internal analog section.
AGND	31, 32	Analog Ground (Input) - Ground reference for the internal analog section.
NC	33, 34	No Connect - These pins are not connected internally and should be tied to ground to minimize any potential coupling effects.
TSTO	35	Test Pin (Output) - This pin must be left unconnected.
VLS	36	Serial Audio Interface Power (Input) - Determines the required signal level for the serial audio interface. Refer to the Recommended Operating Conditions for appropriate voltages.
TSTI	37	Test Pin (Input) - This pin must be connected to ground.
NC	38, 39, 40	No Connect - These pins are not connected internally and should be tied to ground to minimize any potential coupling effects.
SDOUT	41	Serial Audio Data Output (Output) - Output for two's complement serial audio data.
SCLK	42	Serial Clock (Input/Output) - Serial clock for the serial audio interface.
LRCK	43	Left Right Clock (Input/Output) - Determines which channel, Left or Right, is currently active on the serial audio data line.
MCLK	44	Master Clock (Input/Output) - Clock source for the ADC's delta-sigma modulators.
DGND	45	Digital Ground (Input) - Ground reference for the internal digital section.
VD	46	Digital Power (Input) - Positive power for the internal digital section.
INT	47	Interrupt (Output) - Indicates an interrupt condition has occurred.
OVFL	48	Overflow (Output) - Indicates an ADC overflow condition is present.

2. CHARACTERISTICS AND SPECIFICATIONS

(All Min/Max characteristics and specifications are guaranteed over the Specified Operating Conditions. Typical performance characteristics and specifications are derived from measurements taken at nominal supply voltages and $T_A = 25^\circ\text{C}$.)

SPECIFIED OPERATING CONDITIONS (AGND = DGND = 0 V; All voltages with respect to ground.)

Parameters	Symbol	Min	Nom	Max	Units	
DC Power Supplies:	Analog	VA	3.1	5.0	5.25	V
	Digital	VD	3.1	3.3	5.25	V
	Logic - Serial Port	VLS	1.71	3.3	5.25	V
	Logic - Control Port	VLC	1.71	3.3	5.25	V
Ambient Operating Temperature (Power Applied)	T_A	-10	-	+70	$^\circ\text{C}$	

ABSOLUTE MAXIMUM RATINGS (AGND = DGND = 0 V All voltages with respect to ground.) (Note 1)

Parameter	Symbol	Min	Typ	Max	Units	
DC Power Supplies:	Analog	VA	-0.3	-	+6.0	V
	Digital	VD	-0.3	-	+6.0	V
	Logic - Serial Port	VLS	-0.3	-	+6.0	V
	Logic - Control Port	VLC	-0.3	-	+6.0	V
Input Current (Note 2)	I_{in}	-	-	± 10	mA	
Analog Input Voltage	V_{INA}	AGND-0.3	-	VA+0.3	V	
Digital Input Voltage	Logic - Serial Port	V_{IND-S}	-0.3	-	VLS+0.3	V
	Logic - Control Port	V_{IND-C}	-0.3	-	VLC+0.3	V
Ambient Operating Temperature (Power Applied)	T_A	-20	-	+85	$^\circ\text{C}$	
Storage Temperature	T_{stg}	-65	-	+150	$^\circ\text{C}$	

- Notes:
1. Operation beyond these limits may result in permanent damage to the device. Normal operation is not guaranteed at these extremes.
 2. Any pin except supplies. Transient currents of up to ± 100 mA on the analog input pins will not cause SCR latch-up.

ADC ANALOG CHARACTERISTICS Test conditions (unless otherwise specified): Input test signal is a 1 kHz sine wave; measurement bandwidth is 10 Hz to 20 kHz. $F_s = 48/96/192$ kHz.

Line Level Inputs

Parameter	Symbol	Min	Typ	Max	Unit
Dynamic Performance for VA = 5 V					
Dynamic Range					
(Note 4)	PGA Setting: -12 dB to +6 dB				
	A-weighted	99	105	-	dB
	unweighted	96	102	-	dB
(Note 4)	40 kHz bandwidth unweighted	-	99	-	dB
(Note 4)	PGA Setting: +12 dB Gain				
	A-weighted	93	99	-	dB
	unweighted	90	96	-	dB
(Note 4)	40 kHz bandwidth unweighted	-	93	-	dB
Total Harmonic Distortion + Noise (Note 3)	THD+N				
(Note 4)	PGA Setting: -12 dB to +6 dB				
	-1 dB	-	-95	-89	dB
	-20 dB	-	-82	-	dB
	-60 dB	-	-42	-	dB
(Note 4)	40 kHz bandwidth -1 dB	-	-92	-	dB
(Note 4)	PGA Setting: +12 dB Gain				
	-1 dB	-	-92	-86	dB
	-20 dB	-	-76	-	dB
	-60 dB	-	-36	-	dB
(Note 4)	40 kHz bandwidth -1 dB	-	-89	-	dB
Dynamic Performance for VA = 3.3 V					
Dynamic Range					
(Note 4)	PGA Setting: -12 dB to +6 dB				
	A-weighted	94	102	-	dB
	unweighted	91	99	-	dB
(Note 4)	40 kHz bandwidth unweighted	-	96	-	dB
(Note 4)	PGA Setting: +12 dB Gain				
	A-weighted	90	96	-	dB
	unweighted	87	93	-	dB
(Note 4)	40 kHz bandwidth unweighted	-	90	-	dB

Total Harmonic Distortion + Noise	(Note 3)	THD+N				
	PGA Setting: -12 dB to +6 dB					
	-1 dB	-	-92	-86		dB
	-20 dB	-	-79	-		dB
	-60 dB	-	-39	-		dB
(Note 4)	40 kHz bandwidth -1 dB	-	-84	-		dB
	PGA Setting: +12 dB Gain					
	-1 dB	-	-89	-83		dB
	-20 dB	-	-73	-		dB
	-60 dB	-	-33	-		dB
(Note 4)	40 kHz bandwidth -1 dB	-	-81	-		dB

Line Level Inputs

Parameter	Symbol	Min	Typ	Max	Unit
Interchannel Isolation		-	90	-	dB

Line Level Input Characteristics

Full-scale Input Voltage		0.53*VA	0.56*VA	0.59*VA	V _{pp}
Input Impedance		6.12	6.8	7.48	kΩ
Maximum Interchannel Input Impedance Mismatch		-	5	-	%

Line Level and Microphone Level Inputs

Parameter	Symbol	Min	Typ	Max	Unit
-----------	--------	-----	-----	-----	------

DC Accuracy

Interchannel Gain Mismatch		-	0.1	-	dB
Gain Error			-	±5	%
Gain Drift		-	±100	-	ppm/°C

Programmable Gain Characteristics

Gain Step Size		-	0.5	-	dB
Absolute Gain Step Error		-	-	0.4	dB

ADC ANALOG CHARACTERISTICS (cont)
Microphone Level Inputs

Parameter	Symbol	Min	Typ	Max	Unit
Dynamic Performance for VA = 5 V					
Dynamic Range					
PGA Setting: -12 dB to 0 dB					
A-weighted		77	83	-	dB
unweighted		74	80	-	dB
PGA Setting: +12 dB					
A-weighted		65	71	-	dB
unweighted		62	68	-	dB
Total Harmonic Distortion + Noise (Note 3)	THD+N				
PGA Setting: -12 dB to 0 dB					
-1 dB		-	-80	-74	dB
-20 dB		-	-60	-	dB
-60 dB		-	-20	-	dB
PGA Setting: +12 dB					
-1 dB		-	-68	-	dB
Dynamic Performance for VA = 3.3 V					
Dynamic Range					
PGA Setting: -12 dB to 0 dB					
A-weighted		77	83	-	dB
unweighted		74	80	-	dB
PGA Setting: +12 dB					
A-weighted		65	71	-	dB
unweighted		62	68	-	dB
Total Harmonic Distortion + Noise (Note 3)	THD+N				
PGA Setting: -12 dB to 0 dB					
-1 dB		-	-80	-74	dB
-20 dB		-	-60	-	dB
-60 dB		-	-20	-	dB
PGA Setting: +12 dB					
-1 dB		-	-68	-	dB
Interchannel Isolation		-	30	-	dB
Microphone Level Input Characteristics					
Full-scale Input Voltage		0.013*VA	0.014*VA	0.015*VA	V _{pp}
Input Impedance		-	100	-	kΩ

3. Referred to the typical line level full-scale input voltage

4. Valid for Double and Quad Speed Modes only.

ADC DIGITAL FILTER CHARACTERISTICS

Parameter (Note 5, 7)	Symbol	Min	Typ	Max	Unit
Single Speed Mode					
Passband (-0.1 dB)		0	-	0.4896	Fs
Passband Ripple		-	-	0.035	dB
Stopband		0.5688	-	-	Fs
Stopband Attenuation		70	-	-	dB
Total Group Delay (Fs = Output Sample Rate)	t_{gd}	-	12/Fs	-	s
Double Speed Mode					
Passband (-0.1 dB)		0	-	0.4896	Fs
Passband Ripple		-	-	0.025	dB
Stopband		0.5604	-	-	Fs
Stopband Attenuation		69	-	-	dB
Total Group Delay (Fs = Output Sample Rate)	t_{gd}	-	9/Fs	-	s
Quad Speed Mode					
Passband (-0.1 dB)		0	-	0.2604	Fs
Passband Ripple		-	-	0.025	dB
Stopband		0.5000	-	-	Fs
Stopband Attenuation		60	-	-	dB
Total Group Delay (Fs = Output Sample Rate)	t_{gd}	-	5/Fs	-	s
High Pass Filter Characteristics					
Frequency Response -3.0 dB		-	1	-	Hz
-0.13 dB (Note 6)			20	-	Hz
Phase Deviation @ 20Hz (Note 6)		-	10	-	Deg
Passband Ripple		-	-	0	dB
Filter Settling Time			$10^5/Fs$		s

- Note:
5. Filter response is guaranteed by design.
 6. Response shown is for Fs equal to 48 kHz.
 7. Response is clock dependent and will scale with Fs. Note that the response plots (Figures 13 to 24) are normalized to Fs and can be de-normalized by multiplying the X-axis scale by Fs.

PGAOUT ANALOG CHARACTERISTICS Test conditions (unless otherwise specified): Synchronous mode, $F_s = 48/96/192$ kHz. Input test signal is a 1 kHz sine wave; measurement bandwidth is 10 Hz to 20 kHz.

VA = 5 V

Parameter	Symbol	Min	Typ	Max	Unit
Dynamic Performance with PGA Line Level Input Selected					
Dynamic Range (Note 8)					
PGA Setting: -12 dB to +6 dB					
A-weighted		99	105	-	dB
unweighted		96	102	-	dB
PGA Setting: +12 dB Gain					
A-weighted		93	99	-	dB
unweighted		90	96	-	dB
Total Harmonic Distortion + Noise (Note 8)	THD+N				
PGA Setting: -12 dB to +12 dB					
-1 dB		-	-80	-74	dB
-20 dB		-	-82	-	dB
-60 dB		-	-42	-	dB
Dynamic Performance with PGA Mic Level Input Selected					
Dynamic Range (Note 8)					
PGA Setting: -12 dB to 0 dB					
A-weighted		77	83	-	dB
unweighted		74	80	-	dB
PGA Setting: +12 dB					
A-weighted		65	71	-	dB
unweighted		62	68	-	dB
Total Harmonic Distortion + Noise (Note 8)	THD+N				
PGA Setting: -12 dB to 0 dB					
-1 dB		-	-74	-68	dB
-20 dB		-	-60	-	dB
-60 dB		-	-20	-	dB
PGA Setting: +12 dB					
-1 dB		-	-68	-	dB

Notes: 8. Referred to the typical PGAOUT Full-Scale Output Voltage.

PGAOUT ANALOG CHARACTERISTICS (CONT'D)
VA = 3.3 V

Parameter	Symbol	Min	Typ	Max	Unit
Dynamic Performance with PGA Line Level Input Selected					
Dynamic Range					
PGA Setting: -12 dB to +6 dB					
A-weighted		94	102	-	dB
unweighted		91	99	-	dB
PGA Setting: +12 dB Gain					
A-weighted		90	96	-	dB
unweighted		87	93	-	dB
Total Harmonic Distortion + Noise (Note 8)	THD+N				
PGA Setting: -12 dB to +12 dB					
-1 dB		-	-80	-74	dB
-20 dB		-	-82	-	dB
-60 dB		-	-42	-	dB
Dynamic Performance with PGA Mic Level Input Selected					
Dynamic Range					
PGA Setting: -12 dB to 0 dB					
A-weighted		77	83	-	dB
unweighted		74	80	-	dB
PGA Setting: +12 dB					
A-weighted		65	71	-	dB
unweighted		62	68	-	dB
Total Harmonic Distortion + Noise (Note 8)	THD+N				
PGA Setting: -12 dB to 0 dB					
-1 dB		-	-74	-68	dB
-20 dB		-	-60	-	dB
-60 dB		-	-20	-	dB
PGA Setting: +12 dB					
-1 dB		-	-68	-	dB

PGAOUT ANALOG CHARACTERISTICS (CONT'D)
VA = 5 V or 3.3 V

Parameter	Symbol	Min	Typ	Max	Unit
DC Accuracy					
Interchannel Gain Mismatch		-	0.1	-	dB
Gain Error		-	±5	-	%
Gain Drift		-	±100	-	ppm/°C
Analog Output					
Full-Scale Output Voltage		-	0.56*VA	VA	Vpp
Frequency Response 10 Hz to 20 kHz		-0.1dB	-	+0.1dB	dB
Analog In to Analog Out Phase Shift		-	180	-	deg
DC Current draw from a PGAOUT pin	I _{OUT}	-	-	1	μA
AC-Load Resistance	R _L	100	-	-	kΩ
Load Capacitance	C _L	-	-	20	pF
Output Impedance	Z _{OUT}	-	1	-	kΩ

DC ELECTRICAL CHARACTERISTICS (AGND = DGND = 0 V, all voltages with respect to ground. MCLK=12.288 MHz; Fs=48 kHz, Master Mode)

Parameter	Symbol	Min	Typ	Max	Unit	
Power Supply Current (Normal Operation)	VA = 5 V	IA	-	41	50	mA
	VA = 3.3 V	IA	-	37	45	mA
	VD, VLS, VLC = 5 V	ID	-	39	47	mA
	VD, VLS, VLC = 3.3 V	ID	-	23	28	mA
Power Supply Current. (Power-Down Mode) (Note 9).	VA = 5 V	IA	-	0.30	-	mA
	VLS, VLC, VD=5 V	ID	-	0.54	-	mA
Power Consumption (Normal Operation).	VA, VD, VLS, VLC = 5 V	-	-	400	485	mW
	VA, VD, VLS, VLC = 3.3 V	-	-	198	241	mW
	(Power-Down Mode). VA, VD, VLS, VLC = 5 V	-	-	4.2	-	mW
Power Supply Rejection Ratio (1 kHz) (Note 10)	PSRR	-	60	-	dB	
VQ Characteristics						
Quiescent Voltage	VQ	-	0.5 x VA	-	VDC	
DC Current from VQ (Note 11)	IQ	-	-	1	μA	
VQ Output Impedance	ZQ	-	23	-	kΩ	
FILT+ Nominal Voltage	FILT+	-	VA	-	VDC	
Microphone Bias Voltage	MICBIAS	-	0.8 x VA	-	VDC	
Current from MICBIAS	IMB	-	-	2	mA	

- Notes: 9. Power Down Mode is defines as $\overline{\text{RESET}}$ = Low with all clock and data lines held static and no analog input.
10. Valid with the recommended capacitor values on FILT+ and VQ as shown in the Typical Connection Diagram.
11. Guaranteed by design. The DC current draw represents the allowed current draw due to typical leakage through the electrolytic de-coupling capacitors.

DIGITAL INTERFACE CHARACTERISTICS

Parameters (Note 12)		Symbol	Min	Typ	Max	Units
High-Level Input Voltage	Serial Port	V_{IH}	0.7xVLS	-	-	V
	Control Port	V_{IH}	0.7xVLC	-	-	V
Low-Level Input Voltage	Serial Port	V_{IL}	-	-	0.2xVLS	V
	Control Port	V_{IL}	-	-	0.2xVLC	V
High-Level Output Voltage at $I_o=2$ mA	Serial Port	V_{OH}	VLS-1.0	-	-	V
	Control Port	V_{OH}	VLC-1.0	-	-	V
Low-Level Output Voltage at $I_o=2$ mA	Serial Port	V_{OL}	-	-	0.4	V
	Control Port	V_{OL}	-	-	0.4	V
Input Leakage Current		I_{in}	-	-	±10	μA
Input Capacitance	(Note 13)		-	-	1	pF
Minimum OVFL Active Time			$\frac{10^6}{LRCK}$	-	-	μs

Notes: 12. Serial Port signals include: MCLK, SCLK, LRCK, SDOUT
Control Port signals include: SCL/CCLK, SDA/CDOUT, AD0/ \overline{CS} , AD1/CDIN, \overline{RESET} , INT, OVFL.

13. Guaranteed by design.

SWITCHING CHARACTERISTICS - SERIAL AUDIO PORT (Logic '0' = DGND = 0 V;
 Logic '1' = VL, C_L = 20 pF) (Note 14)

Parameter	Symbol	Min	Typ	Max	Unit	
Sample Rate	Single Speed Mode	F _s	4	-	50	kHz
	Double Speed Mode	F _s	50	-	100	kHz
	Quad Speed Mode	F _s	100	-	200	kHz
MCLK Specifications						
MCLK Frequency	f _{mclk}	1.024	-	51.200	MHz	
MCLK Input Pulse Width High/Low	t _{clkh}	8	-	-	ns	
Master Mode						
LRCK Duty Cycle		-	50	-	%	
SCLK Duty Cycle		-	50	-	%	
SCLK falling to LRCK edge	t _{slr}	-10	-	10	ns	
SCLK falling to SDOUT valid	t _{sdo}	0	-	32	ns	
Slave Mode						
LRCK Duty Cycle		40	50	60	%	
SCLK Period	Single Speed Mode	t _{sclkw}	$\frac{10^9}{(128)F_s}$	-	-	ns
	Double Speed Mode	t _{sclkw}	$\frac{10^9}{(64)F_s}$	-	-	ns
	Quad Speed Mode	t _{sclkw}	$\frac{10^9}{(64)F_s}$	-	-	ns
SCLK Pulse Width High	t _{sclkh}	30	-	-	ns	
SCLK Pulse Width Low	t _{sclkl}	48	-	-	ns	
SCLK falling to LRCK edge	t _{slr}	-10	-	10	ns	
SCLK falling to SDOUT valid	t _{sdo}	0	-	32	ns	

Notes: 14. See Figures 1 and 2 on page 16.

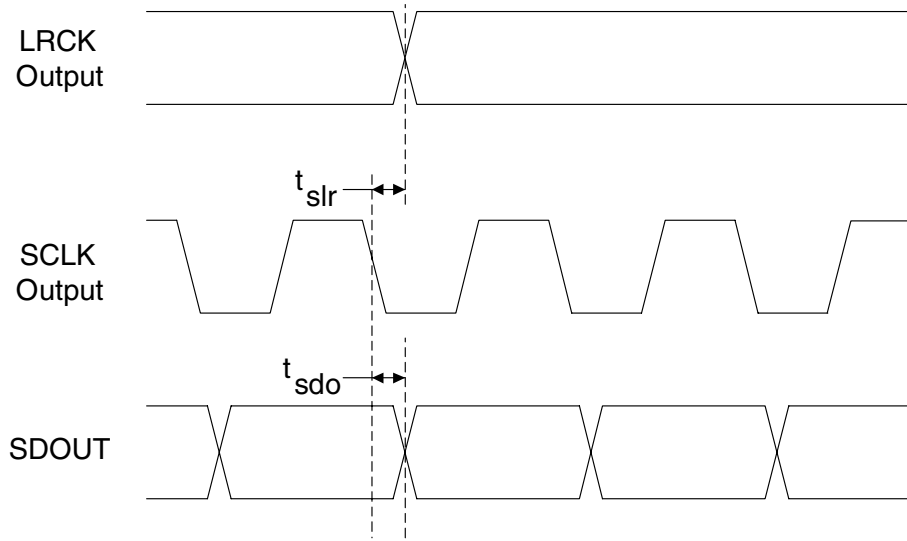

Figure 1. Master Mode Serial Audio Port Timing

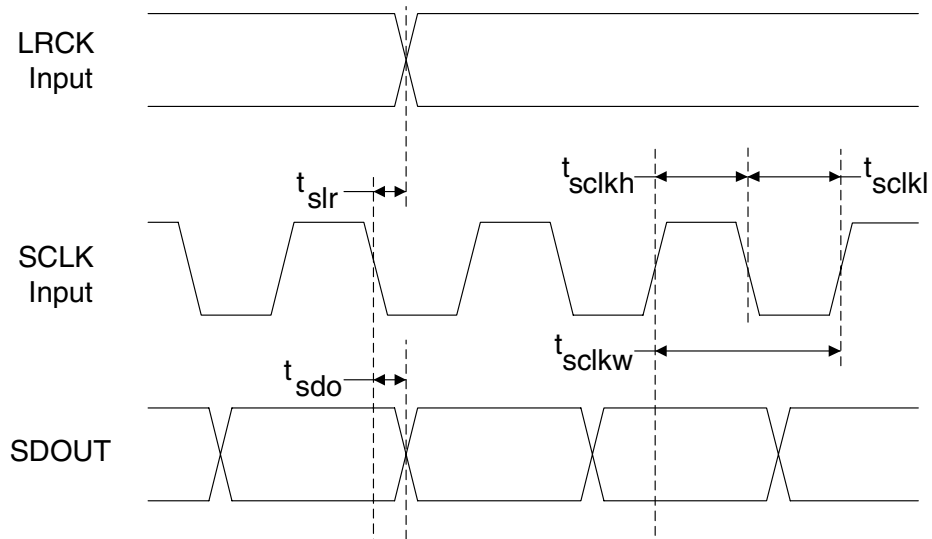

Figure 2. Slave Mode Serial Audio Port Timing

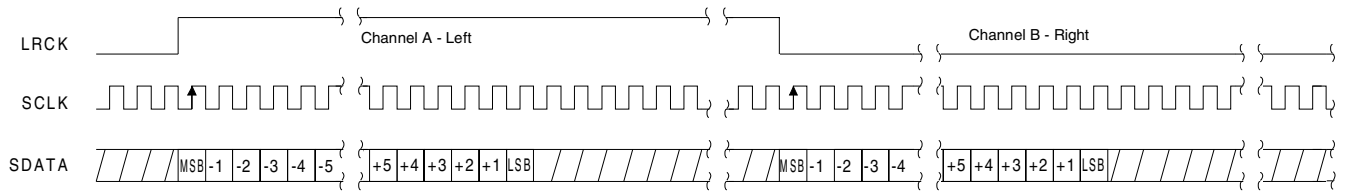

Figure 3. Format 0, Left Justified up to 24-Bit Data

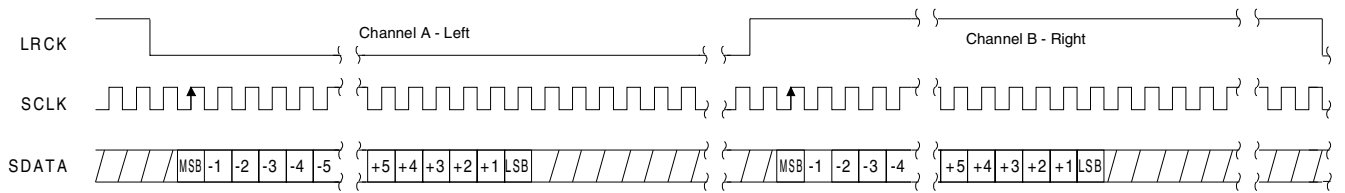

Figure 4. Format 1, I²S up to 24-Bit Data

SWITCHING CHARACTERISTICS - CONTROL PORT - I²C FORMAT

(Inputs: Logic 0 = DGND, Logic 1 = VLC, C_L = 30 pF)

Parameter	Symbol	Min	Max	Unit
SCL Clock Frequency	f_{scl}	-	100	kHz
RESET Rising Edge to Start	t_{irs}	500	-	ns
Bus Free Time Between Transmissions	t_{buf}	4.7	-	μ s
Start Condition Hold Time (prior to first clock pulse)	t_{hdst}	4.0	-	μ s
Clock Low time	t_{low}	4.7	-	μ s
Clock High Time	t_{high}	4.0	-	μ s
Setup Time for Repeated Start Condition	t_{sust}	4.7	-	μ s
SDA Hold Time from SCL Falling (Note 15)	t_{hdd}	0	-	μ s
SDA Setup time to SCL Rising	t_{sud}	250	-	ns
Rise Time of SCL and SDA (Note 16)	t_{rc}	-	1	μ s
Fall Time SCL and SDA (Note 16)	t_{fc}	-	300	ns
Setup Time for Stop Condition	t_{susp}	4.7	-	μ s
Acknowledge Delay from SCL Falling	t_{ack}	300	1000	ns

Notes: 15. Data must be held for sufficient time to bridge the transition time, t_{fc} , of SCL.

16. Guaranteed by design.

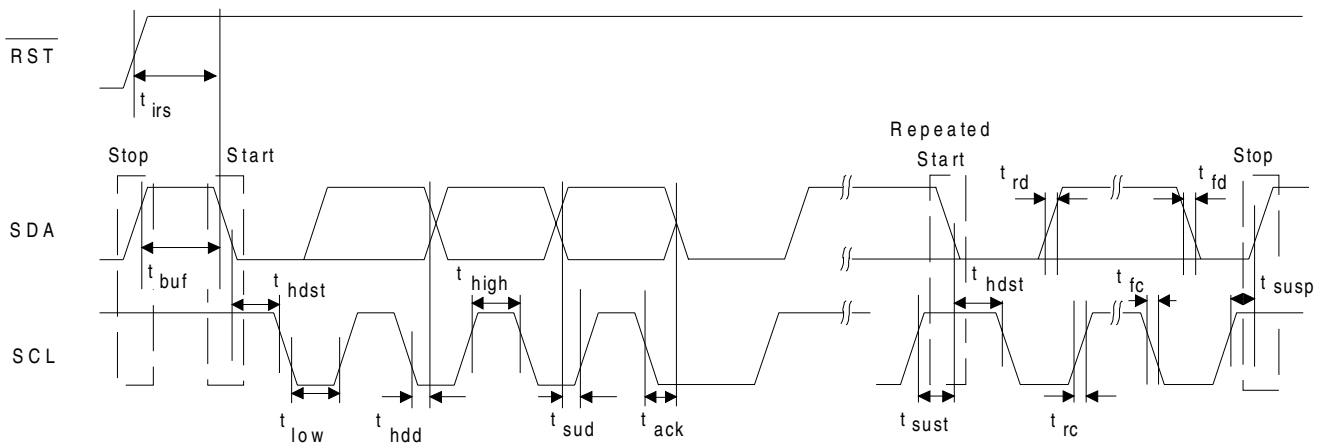

Figure 5. Control Port Timing - I²C Format

SWITCHING CHARACTERISTICS - CONTROL PORT - SPI FORMAT

(Inputs: Logic 0 = DGND, Logic 1 = VLC, $C_L = 30$ pF)

Parameter	Symbol	Min	Typ	Max	Units
CCLK Clock Frequency	f_{sck}	0	-	6.0	MHz
$\overline{\text{RESET}}$ Rising Edge to $\overline{\text{CS}}$ Falling.	t_{srs}	500	-	ns	
$\overline{\text{CS}}$ High Time Between Transmissions	t_{csh}	1.0	-	-	μs
$\overline{\text{CS}}$ Falling to CCLK Edge	t_{css}	20	-	-	ns
CCLK Low Time	t_{scl}	66	-	-	ns
CCLK High Time	t_{sch}	66	-	-	ns
CDIN to CCLK Rising Setup Time	t_{dsu}	40	-	-	ns
CCLK Rising to DATA Hold Time (Note 17)	t_{dh}	15	-	-	ns
CCLK Falling to CDOUT Stable	t_{pd}	-	-	50	ns
Rise Time of CDOUT	t_{r1}	-	-	25	ns
Fall Time of CDOUT	t_{f1}	-	-	25	ns
Rise Time of CCLK and CDIN (Note 18)	t_{r2}	-	-	100	ns
Fall Time of CCLK and CDIN (Note 18)	t_{f2}	-	-	100	ns

Notes: 17. Data must be held for sufficient time to bridge the transition time of CCLK.

18. For $f_{sck} < 1$ MHz.

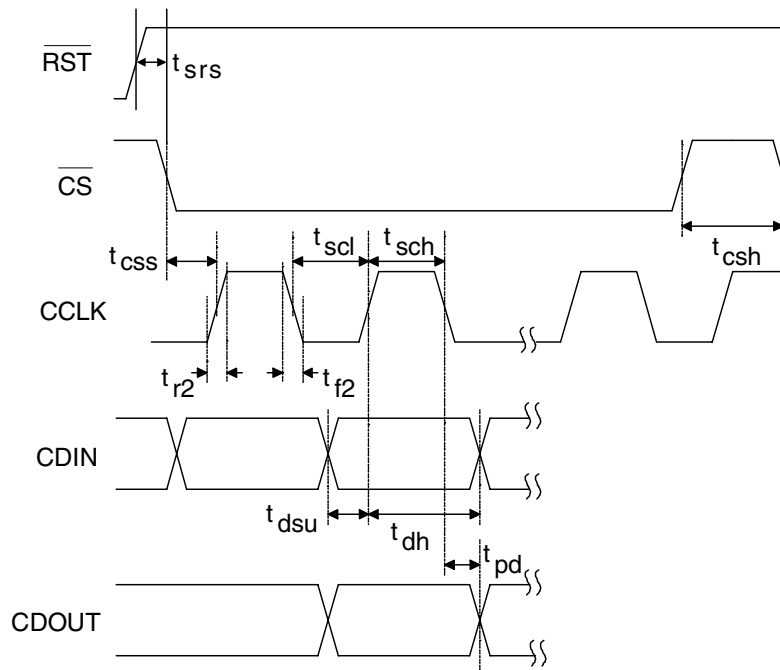

Figure 6. Control Port Timing - SPI Format

3. TYPICAL CONNECTION DIAGRAM

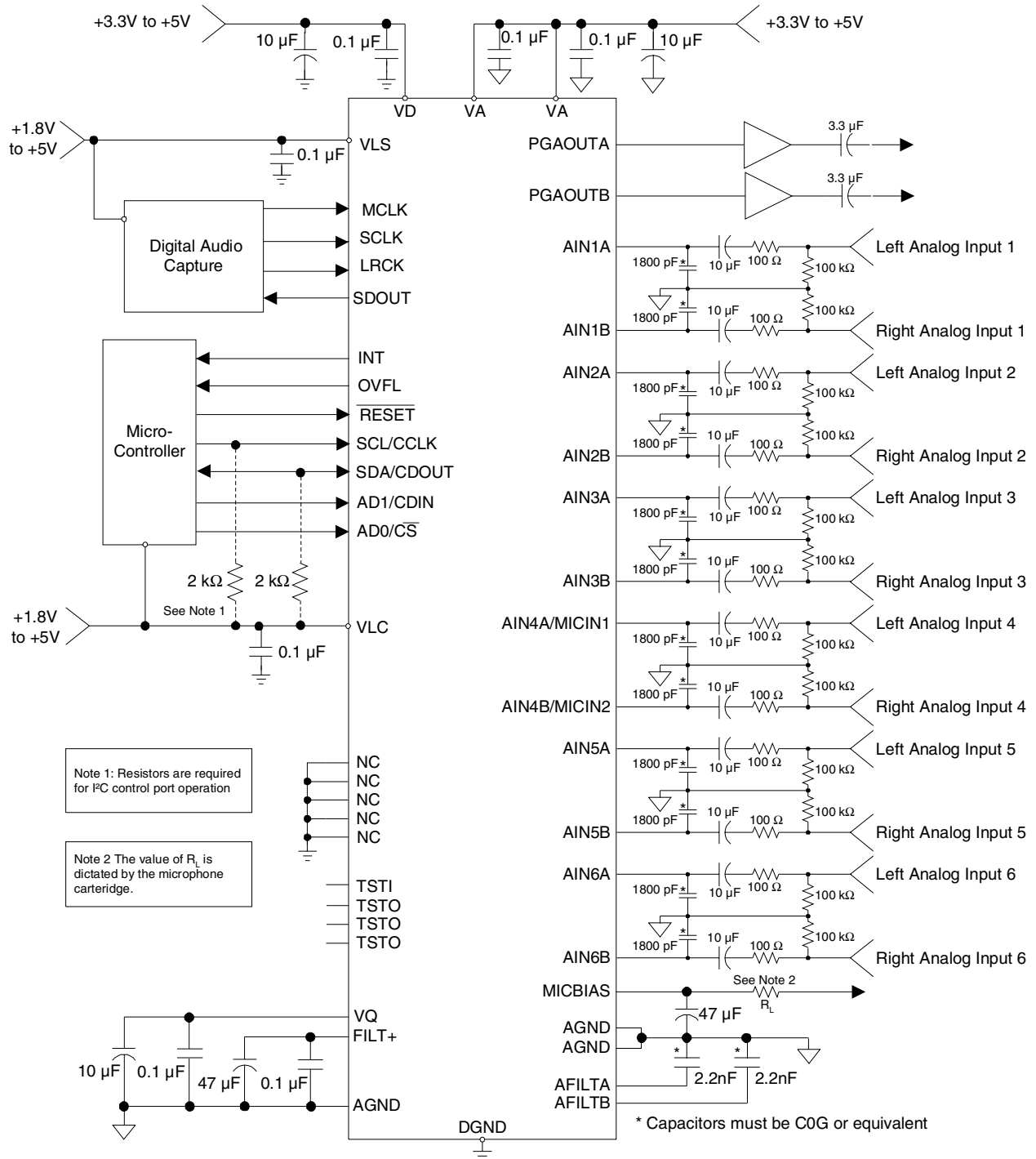

Figure 7. Typical Connection Diagram

R_L

4. APPLICATIONS

4.1 Recommended Power-Up Sequence

- 1) Hold $\overline{\text{RESET}}$ low until the power supply, MCLK, and LRCK are stable. In this state, the Control Port is reset to its default settings.
- 2) Bring $\overline{\text{RESET}}$ high. The device will remain in a low power state with the PDN bit set by default. The control port will be accessible.
- 3) The desired register settings can be loaded while the PDN bit remains set.
- 4) Clear the PDN bit to initiate the power-up sequence.

4.2 System Clocking

The CS5345 will operate at sampling frequencies from 4 kHz to 200 kHz. This range is divided into three speed modes as shown in Table 1 below.

Mode	Sampling Frequency
<i>Single Speed</i>	4-50 kHz
<i>Double Speed</i>	50-100 kHz
<i>Quad Speed</i>	100-200 kHz

Table 1. Speed Modes

4.2.1 Master Clock

MCLK/LRCK must maintain an integer ratio as shown in Table 2. The LRCK frequency is equal to F_s , the frequency at which audio samples for each channel are clocked out of the device. The FM bits (see page 30) and the MCLK Freq bits (see page 30) configure the device to generate the proper clocks in Master Mode and receive the proper clocks in Slave Mode. Table 2 illustrates several standard audio sample rates and the required MCLK and LRCK frequencies.

LRCK (kHz)	MCLK (MHz)								
	64x	96x	128x	192x	256x	384x	512x	768x	1024x
32	-	-	-	-	8.1920	12.2880	16.3840	24.5760	32.7680
44.1	-	-	-	-	11.2896	16.9344	22.5792	33.8680	45.1584
48	-	-	-	-	12.2880	18.4320	24.5760	36.8640	49.1520
64	-	-	8.1920	12.2880	16.3840	24.5760	32.7680	-	-
88.2	-	-	11.2896	16.9344	22.5792	33.8680	45.1584	-	-
96	-	-	12.2880	18.4320	24.5760	36.8640	49.1520	-	-
128	8.1920	12.2880	16.3840	24.5760	32.7680	-	-	-	-
176.4	11.2896	16.9344	22.5792	33.8680	45.1584	-	-	-	-
192	12.2880	18.4320	24.5760	36.8640	49.1520	-	-	-	-
Mode	QSM					DSM		SSM	

Table 2. Common Clock Frequencies

4.2.2 Master Mode

As a clock master, LRCK and SCLK will operate as outputs. LRCK and SCLK are internally derived from MCLK with LRCK equal to F_s and SCLK equal to $64 \times F_s$ as shown in Figure 8.

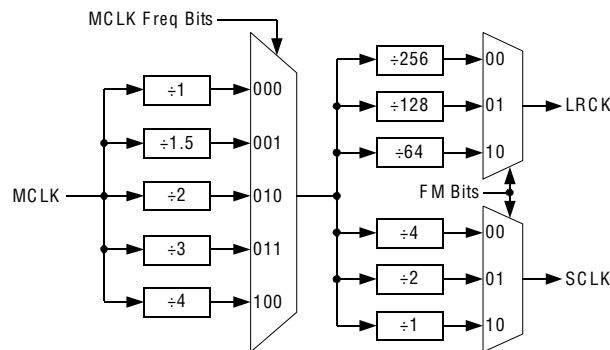
Figure 8. Master Mode Clocking

4.2.3 Slave Mode

In Slave mode, SCLK and LRCK operate as inputs. The Left/Right clock signal must be equal to the sample rate, F_s , and must be synchronously derived from the supplied master clock, MCLK.

The serial bit clock, SCLK, must be synchronously derived from the master clock, MCLK, and be equal to 128x, 64x, 48x or 32x F_s depending on the desired speed mode. Refer to Table 3 for required clock ratios.

	Single Speed	Double Speed	Quad Speed
SCLK/LRCK Ratio	32x, 48x, 64x, 128x	32x, 48x, 64x	32x, 48x, 64x

Table 3. Slave Mode Serial Bit Clock Ratios

4.3 High Pass Filter and DC Offset Calibration

When using operational amplifiers in the input circuitry driving the CS5345, a small DC offset may be driven into the A/D converter. The CS5345 includes a high pass filter after the decimator to remove any DC offset which could result in recording a DC level, possibly yielding clicks when switching between devices in a multichannel system.

The high pass filter continuously subtracts a measure of the DC offset from the output of the decimation filter. If the HPFFreeze bit (see page 30) is set during normal operation, the current value of the DC offset for the each channel is frozen and this DC offset will continue to be subtracted from the conversion result. This feature makes it possible to perform a system DC offset calibration by:

- 1) Running the CS5345 with the high pass filter enabled until the filter settles. See the Digital Filter Characteristics section for filter settling time.
- 2) Disabling the high pass filter and freezing the stored DC offset.

A system calibration performed in this way will eliminate offsets anywhere in the signal path between the calibration point and the CS5345.

4.4 Analog Input Multiplexer, PGA, and Mic Gain

The CS5345 contains a stereo 6-to-1 analog input multiplexer followed by a programmable gain amplifier (PGA). The input multiplexer can select one of 6 possible stereo analog input sources and route it to the PGA. Analog inputs 4A and 4B are able to insert a +32 dB gain stage before the input multiplexer, allowing them to be used for microphone level signals without the need for any external gain. The PGA stage provides ± 12 dB of gain or attenuation in 0.5 dB steps. Figure 9 shows the architecture of the input multiplexer, PGA, and mic gain stages.

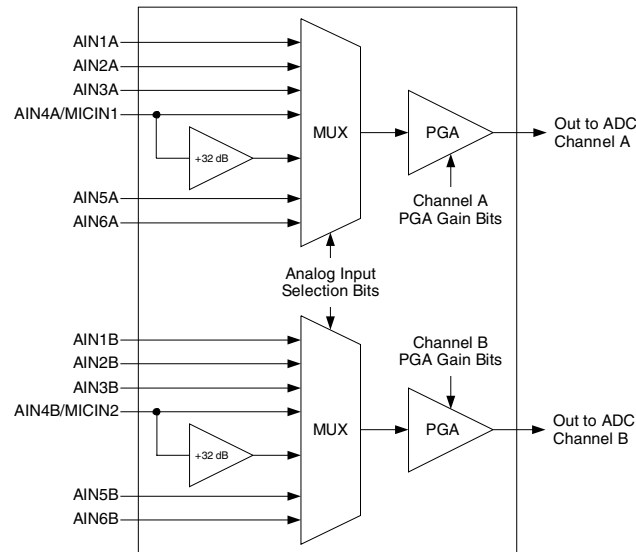

Figure 9. Analog Input Architecture

The “Analog Input Selection (Bits 2:0)” section on page 33 outlines the bit settings necessary to control the input multiplexer and mic gain. “Channel A PGA Control - Address 07h” on page 31 and “Channel B PGA Control - Address 08h” on page 31 outlines the register settings necessary to control the PGA. By default, line level input 1 is selected, and the PGA is set to 0 dB.

4.5 Input Connections

The analog modulator samples the input at 6.144 MHz (MCLK=12.288 MHz). The digital filter will reject signals within the stopband of the filter. However, there is no rejection for input signals which are $(n \times 6.144 \text{ MHz})$ the digital passband frequency, where $n=0,1,2,\dots$. Refer to the Typical Connection Diagram for the recommended analog input circuit that will attenuate noise energy at 6.144 MHz. The use of capacitors which have a large voltage coefficient (such as general purpose ceramics) must be avoided since these can degrade signal linearity. Any unused analog input pairs should be left unconnected.

4.6 PGA Auxiliary Analog Output

The CS5345 includes an auxiliary analog output through the PGAOUT pins. These pins can be configured to output the analog input to the ADC as selected by the input MUX and gained or attenuated with the PGA, or alternatively, they may be set to high-impedance. See the “PGAOut Source Select (Bit 6)” section on page 31 for information on configuring the PGA auxiliary analog output.

The PGA auxiliary analog output can source very little current. As current from the PGAOUT pins increases, distortion will increase. For this reason, a high input impedance buffer must be used on the PGAOUT pins to achieve full performance. Refer to the PGAOUT Analog Characteristics table on page 12 for acceptable loading conditions.

4.7 Control Port Description and Timing

The control port is used to access the registers, allowing the CS5345 to be configured for the desired operational modes and formats. The operation of the control port may be completely asynchronous with respect to the audio sample rates. However, to avoid potential interference problems, the control port pins should remain static if no operation is required.

The control port has 2 modes: SPI and I²C, with the CS5345 acting as a slave device. SPI mode is selected if there is a high to low transition on the AD0/CS pin, after the RESET pin has been brought high. I²C mode is selected by connecting the AD0/CS pin through a resistor to VLC or DGND, thereby permanently selecting the desired AD0 bit address state.

4.7.1 SPI Mode

In SPI mode, \overline{CS} is the CS5345 chip select signal, CCLK is the control port bit clock (input into the CS5345 from the microcontroller), CDIN is the input data line from the microcontroller, CDOUT is the output data line to the microcontroller. Data is clocked in on the rising edge of CCLK and out on the falling edge.

Figure 10 shows the operation of the control port in SPI mode. To write to a register, bring \overline{CS} low. The first seven bits on CDIN form the chip address and must be 1001111. The eighth bit is a read/write indicator (R/W), which should be low to write. The next eight bits form the Memory Address Pointer (MAP), which is set to the address of the register that is to be updated. The next eight bits are the data which will be placed into the register designated by the MAP. During writes, the CDOUT output stays in the Hi-Z state. It may be externally pulled high or low with a 47 k Ω resistor, if desired.

There is a MAP auto increment capability, enabled by the INCR bit in the MAP register. If INCR is a zero, the MAP will stay constant for successive read or writes. If INCR is set to a 1, the MAP will auto-increment after each byte is read or written, allowing block reads or writes of successive registers.

To read a register, the MAP has to be set to the correct address by executing a partial write cycle which finishes (\overline{CS} high) immediately after the MAP byte. The MAP auto increment bit (INCR) may be set or not, as desired. To begin a read, bring \overline{CS} low, send out the chip address and set the read/write bit (R/W) high. The next falling edge of CCLK

will clock out the MSB of the addressed register (CDOUT will leave the high impedance state). If the MAP auto increment bit is set to 1, the data for successive registers will appear consecutively.

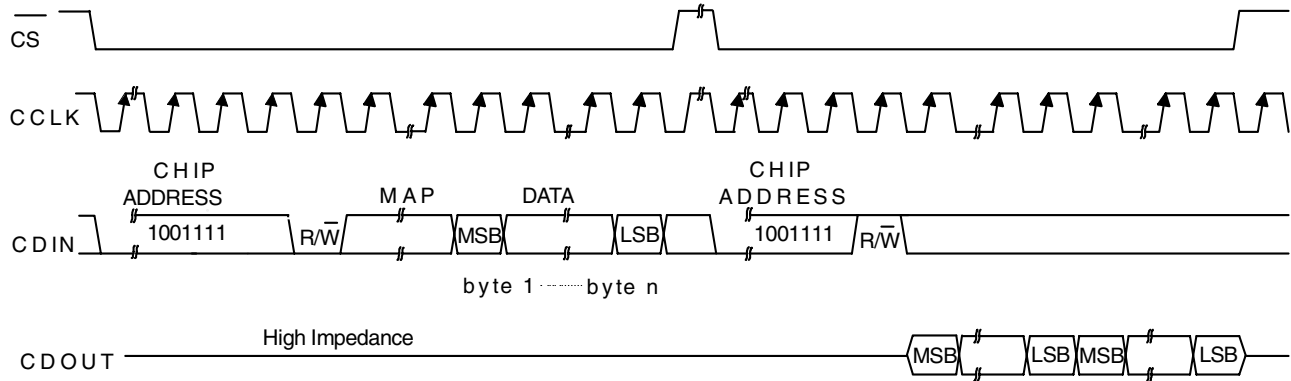

MAP = Memory Address Pointer, 8 bits, MSB first

Figure 10. Control Port Timing in SPI Mode

4.7.2 I²C Mode

In I²C mode, SDA is a bidirectional data line. Data is clocked into and out of the part by the clock, SCL. There is no \overline{CS} pin. Pins AD0 and AD1 form the two least significant bits of the chip address and should be connected through a resistor to VLC or DGND as desired. The state of the pins is sensed while the CS5345 is being reset.

The signal timings for a read and write cycle are shown in Figure 11 and Figure 12. A Start condition is defined as a falling transition of SDA while the clock is high. A Stop condition is a rising transition while the clock is high. All other transitions of SDA occur while the clock is low. The first byte sent to the CS5345 after a Start condition consists of a 7 bit chip address field and a R/\overline{W} bit (high for a read, low for a write). The upper 5 bits of the 7-bit address field are fixed at 10011. To communicate with a CS5345, the chip address field, which is the first byte sent to the CS5345, should match 10011 followed by the settings of the AD1 and AD0. The eighth bit of the address is the R/\overline{W} bit. If the operation is a write, the next byte is the Memory Address Pointer (MAP) which selects the register to be read or written. If the operation is a read, the contents of the register pointed to by the MAP will be output. Setting the auto increment bit in MAP allows successive reads or writes of consecutive registers. Each byte is separated by an acknowledge bit. The ACK bit is output from the CS5345 after each input byte is read, and is input to the CS5345 from the microcontroller after each transmitted byte.

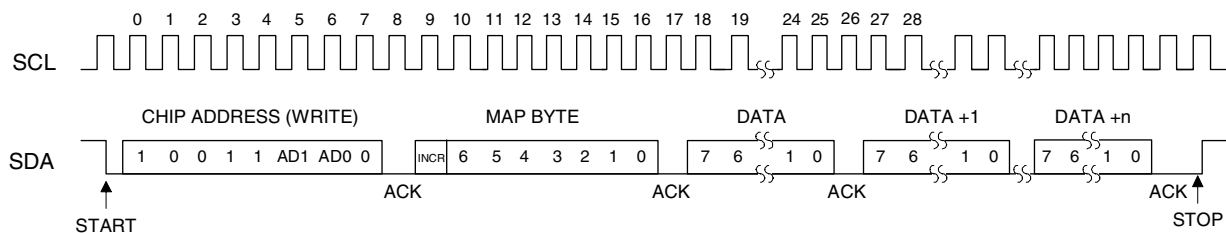

Figure 11. Control Port Timing, I²C Write

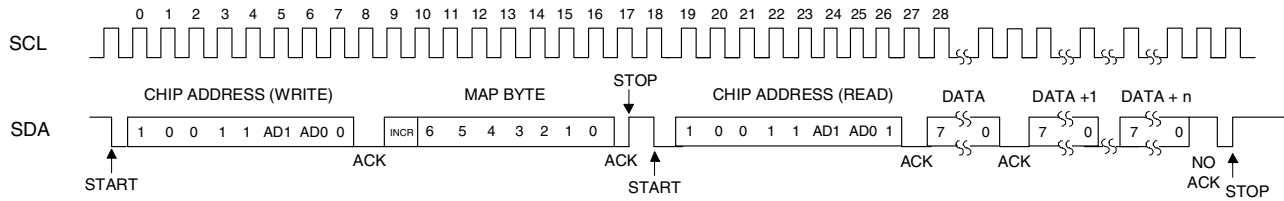

Figure 12. Control Port Timing, I²C Read

Since the read operation can not set the MAP, an aborted write operation is used as a preamble. As shown in Figure 12, the write operation is aborted after the acknowledge for the MAP byte by sending a stop condition. The following pseudocode illustrates an aborted write operation followed by a read operation.

- Send start condition.
- Send 10011xx0 (chip address & write operation).
- Receive acknowledge bit.
- Send MAP byte, auto increment off.
- Receive acknowledge bit.
- Send stop condition, aborting write.
- Send start condition.
- Send 10011xx1(chip address & read operation).
- Receive acknowledge bit.
- Receive byte, contents of selected register.
- Send acknowledge bit.
- Send stop condition.

Setting the auto increment bit in the MAP allows successive reads or writes of consecutive registers. Each byte is separated by an acknowledge bit.

4.8 Interrupts and Overflow

The CS5345 has a comprehensive interrupt capability. The INT output pin is intended to drive the interrupt input pin on the host microcontroller. The INT pin may function as either an active high CMOS driver or an active low open-drain driver (see “Active High/Low (Bit 0)” on page 33). When configured as active low open-drain, the INT pin has no active pull-up transistor, allowing it to be used for wired-OR hook-ups with multiple peripherals connected to the microcontroller interrupt input pin. In this configuration, an external pull-up resistor must be placed on the INT pin for proper operation.

Many conditions can cause an interrupt, as listed in the interrupt status register descriptions. See “Interrupt Status - Address 0Dh” on page 33. Each source may be masked off through mask register bits. In addition, each source may be set to rising edge, falling edge, or level sensitive. Combined with the option of level sensitive or edge sensitive modes within the microcontroller, many different configurations are possible, depending on the needs of the equipment designer.

The CS5345 also has a dedicated overflow output. The OVFL pin functions as active low open drain and has no active pull-up transistor, thereby requiring an external pull-up resistor. The OVFL pin outputs an OR of the ADCOverflow and ADCUnderflow conditions available in the Interrupt Status register, however, these conditions do not need to be unmasked for proper operation of the OVFL pin.

4.9 Reset

When $\overline{\text{RESET}}$ is low, the CS5345 enters a low power mode and all internal states are reset, including the control port and registers, and the outputs are muted. When $\overline{\text{RESET}}$ is high, the control port becomes operational and the desired settings should be loaded into the control registers. Writing a 0 to the PDN bit in the Power Control register will then cause the part to leave the low power state and begin operation.

The delta-sigma modulators settle in a matter of microseconds after the analog section is powered, either through the application of power or by setting the $\overline{\text{RESET}}$ pin high. However, the voltage reference will take much longer to reach a final value due to the presence of external capacitance on the FILT+ pin. During this voltage reference ramp delay, SDOOUT will be automatically muted.

It is recommended that $\overline{\text{RESET}}$ be activated if the analog or digital supplies drop below the recommended operating condition to prevent power glitch related issues.

4.10 Synchronization of Multiple Devices

In systems where multiple ADCs are required, care must be taken to achieve simultaneous sampling. To ensure synchronous sampling, the master clocks and left/right clocks must be the same for all of the CS5345's in the system. If only one master clock source is needed, one solution is to place one CS5345 in Master Mode, and slave all of the other CS5345's to the one master. If multiple master clock sources are needed, a possible solution would be to supply all clocks from the same external source and time the CS5345 reset with the inactive edge of master clock. This will ensure that all converters begin sampling on the same clock edge.

4.11 Grounding and Power Supply Decoupling

As with any high resolution converter, the CS5345 requires careful attention to power supply and grounding arrangements if its potential performance is to be realized. Figure 7 shows the recommended power arrangements, with VA connected to a clean supply. VD, which powers the digital filter, may be run from the system logic supply (VLS or VLC) or may be powered from the analog supply (VA) via a resistor. In this case, no additional devices should be powered from VD. Power supply decoupling capacitors should be as near to the CS5345 as possible, with the low value ceramic capacitor being the nearest. All signals, especially clocks, should be kept away from the FILT+ and VQ pins in order to avoid unwanted coupling into the modulators. The FILT+ and VQ decoupling capacitors, particularly the 0.1 μF , must be positioned to minimize the electrical path from FILT+ and AGND. The CS5345 evaluation board demonstrates the optimum layout and power supply arrangements. To minimize digital noise, connect the CS5345 digital outputs only to CMOS inputs.

5. REGISTER QUICK REFERENCE

This table shows the register names and their associated default values.

Addr	Function	7	6	5	4	3	2	1	0
01h	Chip ID	PART3	PART2	PART1	PART0	REV3	REV2	REV1	REV0
		1	1	1	0	0	0	0	1
02h	Power Control	Freeze	Reserved	Reserved	Reserved	PDN_MIC	PDN_ADC	Reserved	PDN
		0	0	0	0	0	0	0	1
03h	Reserved	Reserved	Reserved	Reserved	Reserved	Reserved	Reserved	Reserved	Reserved
		0	0	0	0	1	0	0	0
04h	ADC Control	FM1	FM0	Reserved	DIF	Reserved	Mute	HPFFreeze	M \bar{S}
		0	0	0	0	0	0	0	0
05h	MCLK Frequency	Reserved	MCLK Freq2	MCLK Freq1	MCLK Freq0	Reserved	Reserved	Reserved	Reserved
		0	0	0	0	0	0	0	0
06h	PGAOut Control	Reserved	PGAOut	Reserved	Reserved	Reserved	Reserved	Reserved	Reserved
		0	1	0	0	0	0	0	0
07h	PGA Ch B Gain Control	Reserved	Reserved	Gain5	Gain4	Gain3	Gain2	Gain1	Gain0
		0	0	0	0	0	0	0	0
08h	PGA Ch A Gain Control	Reserved	Reserved	Gain5	Gain4	Gain3	Gain2	Gain1	Gain0
		0	0	0	0	0	0	0	0
09h	Analog Input Control	Reserved	Reserved	Reserved	PGASoft	PGAZero	Sel2	Sel1	Sel0
		0	0	0	1	1	0	0	1
0Ah - 0Bh	Reserved	Reserved	Reserved	Reserved	Reserved	Reserved	Reserved	Reserved	Reserved
		0	0	0	0	0	0	0	0
0Ch	Active Level Control	Reserved	Reserved	Reserved	Reserved	Reserved	Reserved	Reserved	Active_H/L \bar{L}
		1	1	0	0	0	0	0	0
0Dh	Interrupt Status	Reserved	Reserved	Reserved	EFTC	ClkErr	Reserved	ADCOvf1	ADCUndrf1
		0	0	0	0	0	0	0	0
0Eh	Interrupt Mask	Reserved	Reserved	Reserved	EFTCM	ClkErrM	Reserved	Ovf1M	Undrf1M
		0	0	0	0	0	0	0	0
0Fh	Interrupt Mode MSB	Reserved	Reserved	Reserved	EFTC1	ClkErr1	Reserved	ADCOvf11	ADCUndrf11
		0	0	0	0	0	0	0	0
10h	Interrupt Mode LSB	Reserved	Reserved	Reserved	EFTC1	ClkErr1	Reserved	ADCOvf11	ADCUndrf11
		0	0	0	0	0	0	0	0

6. REGISTER DESCRIPTION

6.1 Chip ID - Register 01h

B7	B6	B5	B4	B3	B2	B1	B0
PART3	PART2	PART1	PART0	REV3	REV2	REV1	REV0

Function:

This register is Read-Only. Bits 7 through 4 are the part number ID which is 1110b (0Eh) and the remaining bits (3 through 0) are for the chip revision.

6.2 Power Control - Address 02h

7	6	5	4	3	2	1	0
Freeze	Reserved	Reserved	Reserved	PDN_MIC	PDN_ADC	Reserved	PDN

6.2.1 Freeze (Bit 7)

Function:

This function allows modifications to be made to certain control port bits without the changes taking effect until the Freeze bit is disabled. To make multiple changes to these bits take effect simultaneously, set the Freeze bit, make all changes, then clear the Freeze bit. The bits affected by the Freeze function are listed in Table 4 below.

Table 4. Freeze-able Bits

Name	Register	Bit(s)
Mute	04h	2
Gain[5:0]	07h	5:0
Gain[5:0]	08h	5:0

6.2.2 Power Down MIC (Bit 3)

Function:

The microphone preamplifier block will enter a low-power state whenever this bit is set.

6.2.3 Power Down ADC (Bit 2)

Function:

The ADC pair will remain in a reset state whenever this bit is set.

6.2.4 Power Down Device (Bit 0)

Function:

The device will enter a low-power state whenever this bit is set. The power-down bit is set by default and must be cleared before normal operation can occur. The contents of the control registers are retained when the device is in power-down.

6.3 ADC Control - Address 04h

7	6	5	4	3	2	1	0
FM1	FM0	Reserved	DIF	Reserved	Mute	HPFFreeze	M/S

6.3.1 Functional Mode (Bits 7:6)

Function:

Selects the required range of sample rates.

Table 5. Functional Mode Selection

FM1	FM0	Mode
0	0	Single-Speed Mode: 4 to 50 kHz sample rates
0	1	Double-Speed Mode: 50 to 100 kHz sample rates
1	0	Quad-Speed Mode: 100 to 200 kHz sample rates
1	1	Reserved

6.3.2 Digital Interface Format (Bit 4)

Function:

The required relationship between LRCK, SCLK and SDOUT is defined by the Digital Interface Format bit. The options are detailed in Table 6 and may be seen in Figure 3 and 4.

Table 6. Digital Interface Formats

DIF	Description	Format	Figure
0	Left Justified, up to 24-bit data (default)	0	3
1	I ² S, up to 24-bit data	1	4

6.3.3 Mute (Bit 2)

Function:

When this bit is set, the serial audio output of the both channels will be muted.

6.3.4 High Pass Filter Freeze (Bit 1)

Function:

When this bit is set, the internal high-pass filter will be disabled. The current DC offset value will be frozen and continue to be subtracted from the conversion result. See “High Pass Filter and DC Offset Calibration” on page 22.

6.3.5 Master / Slave Mode (Bit 0)

Function:

This bit selects either master or slave operation for the serial audio port. Setting this bit will select master mode, while clearing this bit will select slave mode.

6.4 MCLK Frequency - Address 05h

7	6	5	4	3	2	1	0
Reserved	MCLK Freq2	MCLK Freq1	MCLK Freq0	Reserved	Reserved	Reserved	Reserved

6.4.1 Master Clock Dividers (Bits 6:4)

Function:

Sets the frequency of the supplied MCLK signal. See Table 7 below for the appropriate settings.

Table 7. MCLK Frequency

MCLK Divider	MCLK Freq2	MCLK Freq1	MCLK Freq0
÷ 1	0	0	0
÷ 1.5	0	0	1
÷ 2	0	1	0
÷ 3	0	1	1
÷ 4	1	0	0
Reserved	1	0	1
Reserved	1	1	x

6.5 PGAOut Control - Address 06h

7	6	5	4	3	2	1	0
Reserved	PGAOut	Reserved	Reserved	Reserved	Reserved	Reserved	Reserved

6.5.1 PGAOut Source Select (Bit 6)

Function:

This bit is used to configure the PGAOut pins to be either high impedance or PGA outputs. Refer to Table 8 below.

Table 8. PGAOut Source Selection

PGAOut	PGAOutA & PGAOutB
0	High Impedance
1	PGA Output

6.6 Channel A PGA Control - Address 07h

7	6	5	4	3	2	1	0
Reserved	Reserved	Gain5	Gain4	Gain3	Gain2	Gain1	Gain0

6.6.1 Channel A PGA Gain (Bits 5:0)

Function:

See “Channel B PGA Gain (Bits 5:0)” on page 31.

6.7 Channel B PGA Control - Address 08h

7	6	5	4	3	2	1	0
Reserved	Reserved	Gain5	Gain4	Gain3	Gain2	Gain1	Gain0

6.7.1 Channel B PGA Gain (Bits 5:0)

Function:

Sets the gain or attenuation for the ADC input PGA stage. The gain may be adjusted from -12 dB to +12 dB in 0.5 dB steps. The gain bits are in two’s complement with the Gain0 bit set for a 0.5 dB step. Register settings outside of the ±12 dB range are reserved and must not be used. See Table 9 for

example settings.

Table 9. Example Gain and Attenuation Settings

Gain[5:0]	Setting
101000	-12 dB
000000	0 dB
011000	+12 dB

6.8 ADC Input Control - Address 09h

7	6	5	4	3	2	1	0
Reserved	Reserved	Reserved	PGASoft	PGAZero	Sel2	Sel1	Sel0

6.8.1 PGA Soft Ramp or Zero Cross Enable (Bits 4:3)

Function:

Soft Ramp Enable

Soft Ramp allows level changes, both muting and attenuation, to be implemented by incrementally ramping, in 1/8 dB steps, from the current level to the new level at a rate of 1 dB per 8 left/right clock periods. See Table 10 on page 33.

Zero Cross Enable

Zero Cross Enable dictates that signal level changes, either by attenuation changes or muting, will occur on a signal zero crossing to minimize audible artifacts. The requested level change will occur after a time-out period between 512 and 1024 sample periods (10.7 ms to 21.3 ms at 48 kHz sample rate) if the signal does not encounter a zero crossing. The zero cross function is independently monitored and implemented for each channel. See Table 10 on page 33.

Soft Ramp and Zero Cross Enable

Soft Ramp and Zero Cross Enable dictate that signal level changes, either by attenuation changes or muting, will occur in 1/8 dB steps and be implemented on a signal zero crossing. The 1/8 dB level change will occur after a time-out period between 512 and 1024 sample periods (10.7 ms to 21.3 ms at 48 kHz sample rate) if the signal does not encounter a zero crossing. The zero cross function is independently monitored and implemented for each channel. See Table 10 on page 33.

Table 10. PGA Soft Cross or Zero Cross Mode Selection

PGASoft	PGAZeroCross	Mode
0	0	Changes to affect immediately
0	1	Zero Cross enabled
1	0	Soft Ramp enabled
1	1	Soft Ramp and Zero Cross enabled (default)

6.8.2 Analog Input Selection (Bits 2:0)

Function:

These bits are used to select the input source for the PGA and ADC. Please see Table 11 below.

Table 11. Analog Input Multiplexer Selection

Sel2	Sel1	Sel0	PGA/ADC Input
0	0	0	Microphone Level Inputs (+32 dB Gain Enabled)
0	0	1	Line Level Input Pair 1
0	1	0	Line Level Input Pair 2
0	1	1	Line Level Input Pair 3
1	0	0	Line Level Input Pair 4
1	0	1	Line Level Input Pair 5
1	1	0	Line Level Input Pair 6
1	1	1	Reserved

6.9 Active Level Control - Address 0Ch

7	6	5	4	3	2	1	0
Reserved	Reserved	Reserved	Reserved	Reserved	Reserved	Reserved	Active_H/L

6.9.1 Active High/Low (Bit 0)

Function:

When this bit is set, the INT pin will function as an active high CMOS driver.

When this bit is cleared, the INT pin will function as an active low open drain driver and will require an external pull-up resistor for proper operation.

6.10 Interrupt Status - Address 0Dh

7	6	5	4	3	2	1	0
Reserved	Reserved	Reserved	Reserved	ClkErr	Reserved	Ovfl	Undrfl

For all bits in this register, a '1' means the associated interrupt condition has occurred at least once since the register was last read. A '0' means the associated interrupt condition has NOT occurred since the last reading of the register. Status bits that are masked off in the associated mask register will always be '0' in this register. This register defaults to 00h.

6.10.1 Clock Error (Bit 3)

Function:

Indicates the occurrence of a clock error condition.

6.10.2 Overflow (Bit 1)

Function:

Indicates the occurrence of an ADC overflow condition.

6.10.3 Underflow (Bit 0)

Function:

Indicates the occurrence of an ADC underflow condition.

6.11 Interrupt Mask - Address 0Eh

7	6	5	4	3	2	1	0
Reserved	Reserved	Reserved	Reserved	ClkErrM	Reserved	OvflM	UndrfIM

Function:

The bits of this register serve as a mask for the Status sources found in the register “Interrupt Status - Address 0Dh” on page 33. If a mask bit is set to 1, the error is unmasked, meaning that its occurrence will affect the INT pin and the status register. If a mask bit is set to 0, the error is masked, meaning that its occurrence will not affect the INT pin or the status register. The bit positions align with the corresponding bits in the Status register.

6.12 Interrupt Mode MSB - Address 0Fh

6.13 Interrupt Mode LSB - Address 10h

7	6	5	4	3	2	1	0
Reserved	Reserved	Reserved	Reserved	ClkErr1	Reserved	Ovfl1	Undrf1
Reserved	Reserved	Reserved	Reserved	ClkErr0	Reserved	Ovfl0	Undrf0

Function:

The two Interrupt Mode registers form a 2-bit code for each Interrupt Status register function. There are three ways to set the INT pin active in accordance with the interrupt condition. In the Rising edge active mode, the INT pin becomes active on the arrival of the interrupt condition. In the Falling edge active mode, the INT pin becomes active on the removal of the interrupt condition. In Level active mode, the INT pin remains active during the interrupt condition.

00 - Rising edge active

01 - Falling edge active

10 - Level active

11 - Reserved

7. PARAMETER DEFINITIONS

Dynamic Range

The ratio of the rms value of the signal to the rms sum of all other spectral components over the specified bandwidth. Dynamic Range is a signal-to-noise ratio measurement over the specified bandwidth made with a -60 dBFS signal. 60 dB is added to resulting measurement to refer the measurement to full-scale. This technique ensures that the distortion components are below the noise level and do not affect the measurement. This measurement technique has been accepted by the Audio Engineering Society, AES17-1991, and the Electronic Industries Association of Japan, EIAJ CP-307. Expressed in decibels.

Total Harmonic Distortion + Noise

The ratio of the rms value of the signal to the rms sum of all other spectral components over the specified bandwidth (typically 10 Hz to 20 kHz), including distortion components. Expressed in decibels. Measured at -1 and -20 dBFS as suggested in AES17-1991 Annex A.

Frequency Response

A measure of the amplitude response variation from 10 Hz to 20 kHz relative to the amplitude response at 1 kHz. Units in decibels.

Interchannel Isolation

A measure of crosstalk between the left and right channels. Measured for each channel at the converter's output with no signal to the input under test and a full-scale signal applied to the other channel. Units in decibels.

Interchannel Gain Mismatch

The gain difference between left and right channels. Units in decibels.

Gain Error

The deviation from the nominal full-scale analog output for a full-scale digital input.

Gain Drift

The change in gain value with temperature. Units in ppm/°C.

Offset Error

The deviation of the mid-scale transition (111...111 to 000...000) from the ideal. Units in mV.

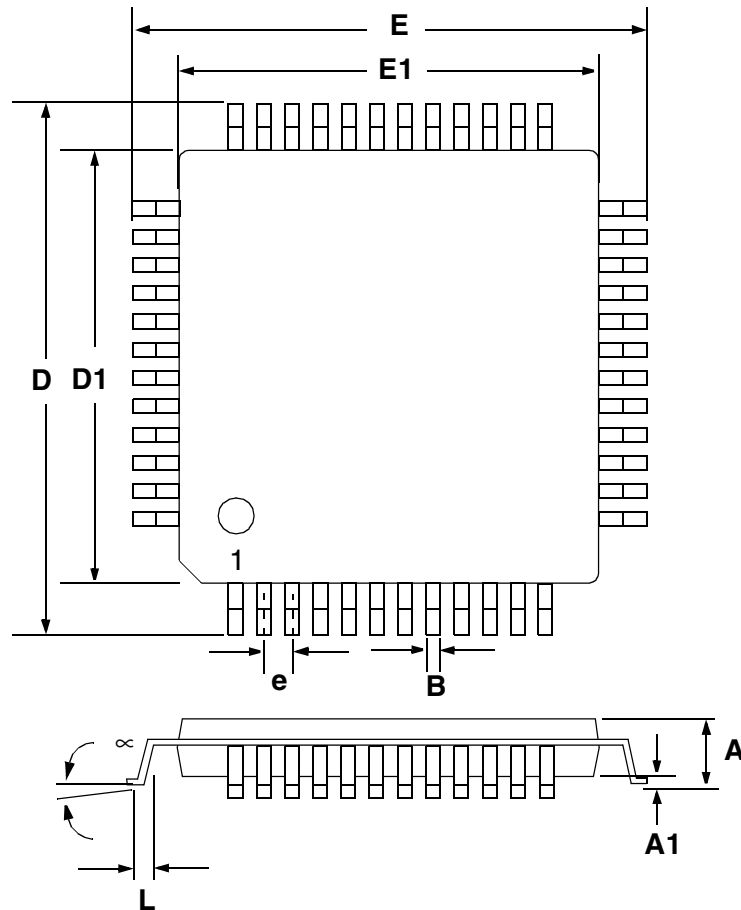
8. PACKAGE DIMENSIONS
48L LQFP PACKAGE DRAWING

DIM	INCHES			MILLIMETERS		
	MIN	NOM	MAX	MIN	NOM	MAX
A	---	0.055	0.063	---	1.40	1.60
A1	0.002	0.004	0.006	0.05	0.10	0.15
B	0.007	0.009	0.011	0.17	0.22	0.27
D	0.343	0.354	0.366	8.70	9.0 BSC	9.30
D1	0.272	0.28	0.280	6.90	7.0 BSC	7.10
E	0.343	0.354	0.366	8.70	9.0 BSC	9.30
E1	0.272	0.28	0.280	6.90	7.0 BSC	7.10
e*	0.016	0.020	0.024	0.40	0.50 BSC	0.60
L	0.018	0.24	0.030	0.45	0.60	0.75
∞	0.000°	4°	7.000°	0.00°	4°	7.00°

* Nominal pin pitch is 0.50 mm

*Controlling dimension is mm.

*JEDEC Designation: MS022

9. THERMAL CHARACTERISTICS AND SPECIFICATIONS

Parameters	Symbol	Min	Typ	Max	Units
Package Thermal Resistance (Note 19)	θ_{JA}	-	48	-	°C/Watt
	θ_{JC}	-	15	-	°C/Watt
Allowable Junction Temperature		-	-	125	°C

Notes: 19. θ_{JA} is specified according to JEDEC specifications for multi-layer PCBs.

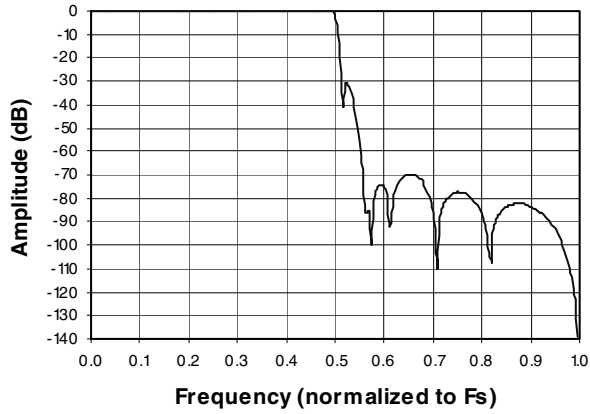
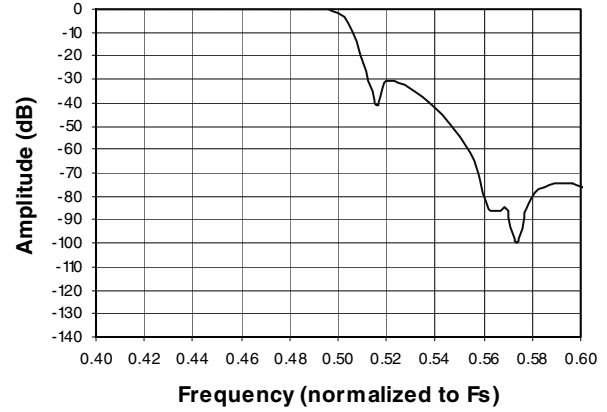
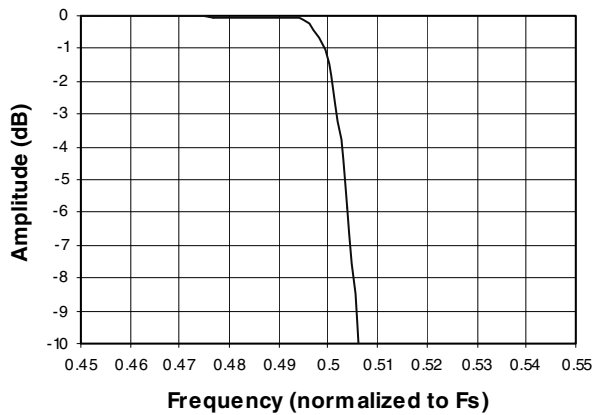
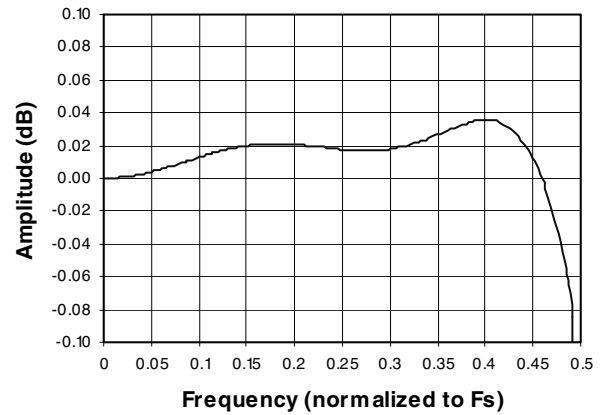
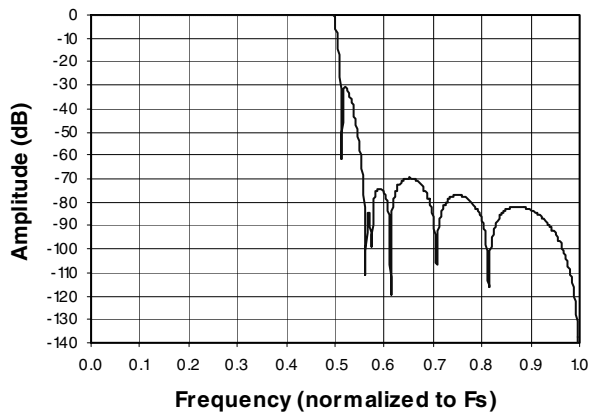
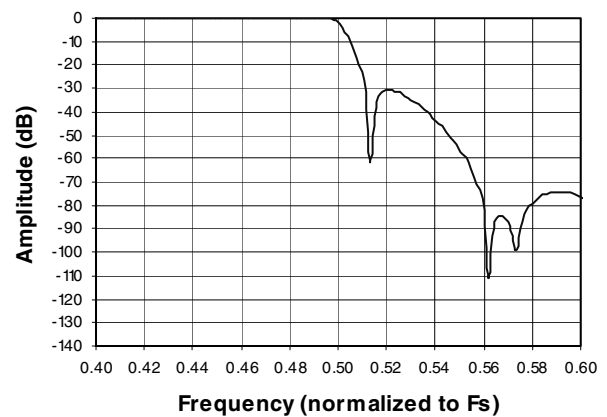
APPENDIX A: FILTER PLOTS

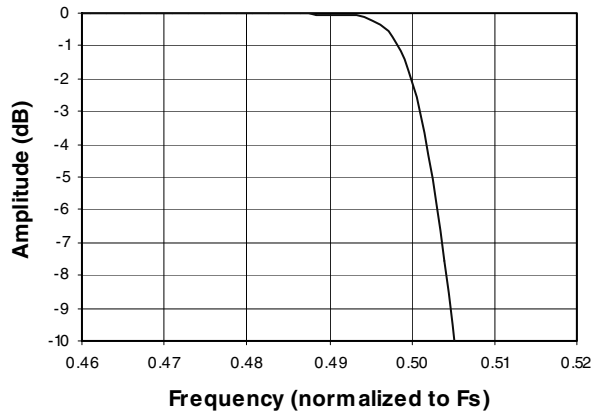
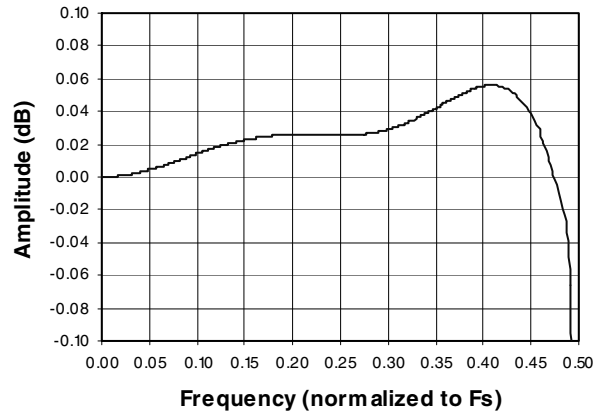
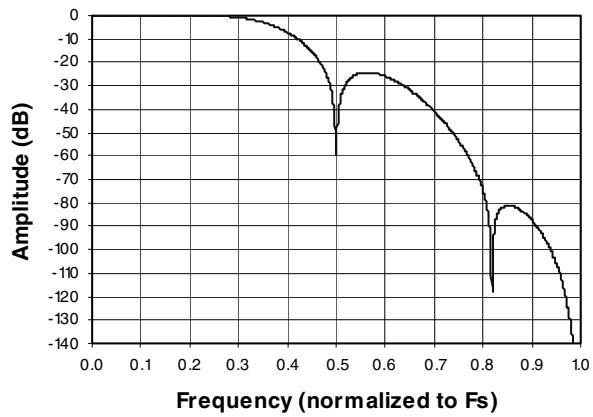
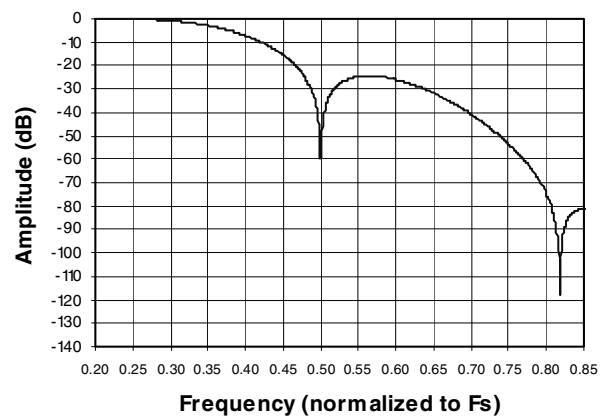
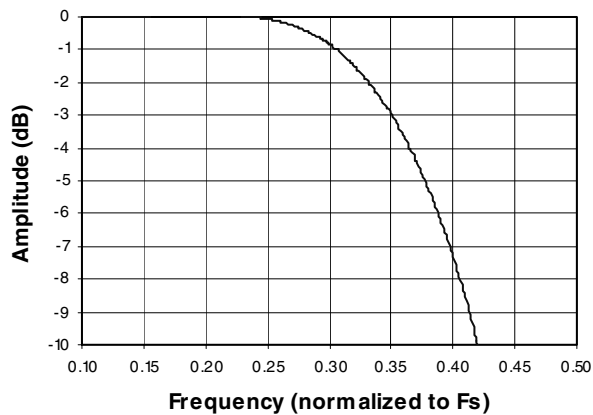
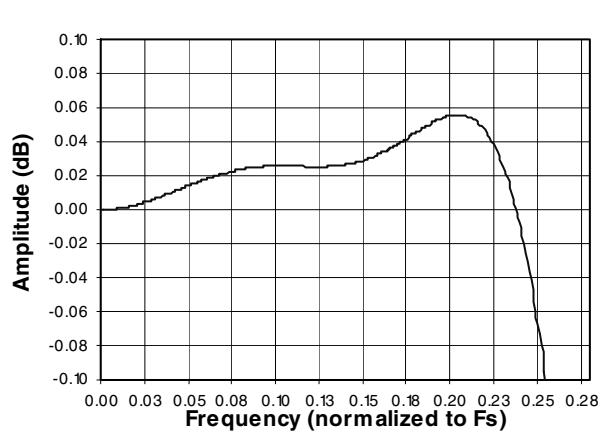
Figure 13. Single Speed Stopband Rejection

Figure 14. Single Speed Stopband Rejection

Figure 15. Single Speed Transition Band (Detail)

Figure 16. Single Speed Passband Ripple

Figure 17. Double Speed Stopband Rejection

Figure 18. Double Speed Stopband Rejection

Figure 19. Double Speed Transition Band (Detail)

Figure 20. Double Speed Passband Ripple

Figure 21. Quad Speed Stopband Rejection

Figure 22. Quad Speed Stopband Rejection

Figure 23. Quad Speed Transition Band (Detail)

Figure 24. Quad Speed Passband Ripple

Release	Date	Changes
A1	June 2004	Initial Release

Table 12. Revision History

Contacting Cirrus Logic Support

For all product questions and inquiries contact a Cirrus Logic Sales Representative.
To find the one nearest to you go to www.cirrus.com

IMPORTANT NOTICE

"Advance" product information describes products that are in development and subject to development changes. Cirrus Logic, Inc. and its subsidiaries ("Cirrus") believe that the information contained in this document is accurate and reliable. However, the information is subject to change without notice and is provided "AS IS" without warranty of any kind (express or implied). Customers are advised to obtain the latest version of relevant information to verify, before placing orders, that information being relied on is current and complete. All products are sold subject to the terms and conditions of sale supplied at the time of order acknowledgment, including those pertaining to warranty, patent infringement, and limitation of liability. No responsibility is assumed by Cirrus for the use of this information, including use of this information as the basis for manufacture or sale of any items, or for infringement of patents or other rights of third parties. This document is the property of Cirrus and by furnishing this information, Cirrus grants no license, express or implied under any patents, mask work rights, copyrights, trademarks, trade secrets or other intellectual property rights. Cirrus owns the copyrights associated with the information contained herein and gives consent for copies to be made of the information only for use within your organization with respect to Cirrus integrated circuits or other products of Cirrus. This consent does not extend to other copying such as copying for general distribution, advertising or promotional purposes, or for creating any work for resale.

CERTAIN APPLICATIONS USING SEMICONDUCTOR PRODUCTS MAY INVOLVE POTENTIAL RISKS OF DEATH, PERSONAL INJURY, OR SEVERE PROPERTY OR ENVIRONMENTAL DAMAGE ("CRITICAL APPLICATIONS"). CIRRUS PRODUCTS ARE NOT DESIGNED, AUTHORIZED OR WARRANTED FOR USE IN AIRCRAFT SYSTEMS, MILITARY APPLICATIONS, PRODUCTS SURGICALLY IMPLANTED INTO THE BODY, LIFE SUPPORT PRODUCTS OR OTHER CRITICAL APPLICATIONS (INCLUDING MEDICAL DEVICES, AIRCRAFT SYSTEMS OR COMPONENTS AND PERSONAL OR AUTOMOTIVE SAFETY OR SECURITY DEVICES). INCLUSION OF CIRRUS PRODUCTS IN SUCH APPLICATIONS IS UNDERSTOOD TO BE FULLY AT THE CUSTOMER'S RISK AND CIRRUS DISCLAIMS AND MAKES NO WARRANTY, EXPRESS, STATUTORY OR IMPLIED, INCLUDING THE IMPLIED WARRANTIES OF MERCHANTABILITY AND FITNESS FOR PARTICULAR PURPOSE, WITH REGARD TO ANY CIRRUS PRODUCT THAT IS USED IN SUCH A MANNER. IF THE CUSTOMER OR CUSTOMER'S CUSTOMER USES OR PERMITS THE USE OF CIRRUS PRODUCTS IN CRITICAL APPLICATIONS, CUSTOMER AGREES, BY SUCH USE, TO FULLY INDEMNIFY CIRRUS, ITS OFFICERS, DIRECTORS, EMPLOYEES, DISTRIBUTORS AND OTHER AGENTS FROM ANY AND ALL LIABILITY, INCLUDING ATTORNEYS' FEES AND COSTS, THAT MAY RESULT FROM OR ARISE IN CONNECTION WITH THESE USES.

Cirrus Logic, Cirrus, the Cirrus Logic logo designs, and Popguard are trademarks of Cirrus Logic, Inc. All other brand and product names in this document may be trademarks or service marks of their respective owners.

I2C is a registered trademark of Philips Semiconductor. Purchase of I2C Components of Cirrus Logic, Inc., or one of its sublicensed Associated Companies conveys a license under the Philips I2C Patent Rights to use those components in a standard I2C system.