

DATA SHEET

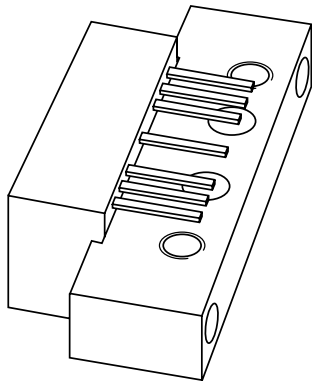

BGY685A

**600 MHz, 18.2 dB gain push-pull
amplifier**

Product specification
Supersedes data of 1998 Mar 16

2001 Oct 22

600 MHz, 18.2 dB gain push-pull amplifier

BGY685A

FEATURES

- Excellent linearity
- Extremely low noise
- Silicon nitride passivation
- Rugged construction
- Gold metallization ensures excellent reliability.

DESCRIPTION

Special super-high dynamic range amplifier module designed for applications in CATV systems with a bandwidth of 40 to 600 MHz operating at a voltage supply of 24 V (DC).

PINNING - SOT115J

PIN	DESCRIPTION
1	input
2	common
3	common
5	+V _B
7	common
8	common
9	output

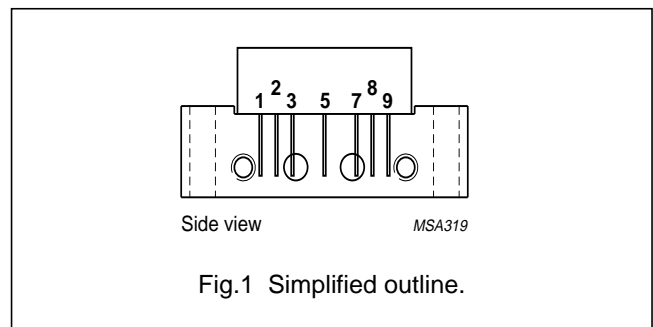

QUICK REFERENCE DATA

SYMBOL	PARAMETER	CONDITIONS	MIN.	TYP.	MAX.	UNIT
G _p	power gain	f = 50 MHz	17.7	–	18.7	dB
		f = 600 MHz	19	–	–	dB
I _{tot}	total current consumption (DC)	V _B = 24 V	–	220	240	mA

LIMITING VALUES

In accordance with the Absolute Maximum Rating System (IEC 60134).

SYMBOL	PARAMETER	MIN.	MAX.	UNIT
V _i	RF input voltage	–	65	dBmV
T _{stg}	storage temperature	–40	+100	°C
T _{mb}	operating mounting base temperature	–20	+100	°C

600 MHz, 18.2 dB gain push-pull amplifier

BGY685A

CHARACTERISTICS

Table 1 Bandwidth 40 to 600 MHz; $T_{\text{case}} = 30\text{ }^{\circ}\text{C}$; $Z_S = Z_L = 75\ \Omega$

SYMBOL	PARAMETER	CONDITIONS	MIN.	MAX.	UNIT
G_p	power gain	$f = 50\text{ MHz}$	17.7	18.7	dB
		$f = 600\text{ MHz}$	19	–	dB
SL	slope cable equivalent	$f = 40\text{ to }600\text{ MHz}$	0.5	2.2	dB
FL	flatness of frequency response	$f = 40\text{ to }600\text{ MHz}$	–	± 0.2	dB
S_{11}	input return losses	$f = 40\text{ to }80\text{ MHz}$	20	–	dB
		$f = 80\text{ to }160\text{ MHz}$	19	–	dB
		$f = 160\text{ to }600\text{ MHz}$	18	–	dB
S_{22}	output return losses	$f = 40\text{ to }80\text{ MHz}$	20	–	dB
		$f = 80\text{ to }160\text{ MHz}$	19	–	dB
		$f = 160\text{ to }600\text{ MHz}$	18	–	dB
S_{21}	phase response	$f = 50\text{ MHz}$	–45	+45	deg
CTB	composite triple beat	85 channels flat; $V_o = 44\text{ dBmV}$; measured at 595.25 MHz	–	–55	dB
X_{mod}	cross modulation	85 channels flat; $V_o = 44\text{ dBmV}$; measured at 55.25 MHz	–	–60	dB
CSO	composite second order distortion	85 channels flat; $V_o = 44\text{ dBmV}$; measured at 596.5 MHz	–	–56	dB
d_2	second order distortion	note 1	–	–70	dB
V_o	output voltage	$d_{\text{im}} = -60\text{ dB}$; note 2	60	–	dBmV
F	noise figure	$f = 600\text{ MHz}$	–	8.5	dB
I_{tot}	total current consumption (DC)	note 3	–	240	mA

Notes

- $f_p = 55.25\text{ MHz}$; $V_p = 44\text{ dBmV}$;
 $f_q = 541.25\text{ MHz}$; $V_q = 44\text{ dBmV}$;
measured at $f_p + f_q = 596.5\text{ MHz}$.
- $f_p = 590.25\text{ MHz}$; $V_p = V_o$;
 $f_q = 597.25\text{ MHz}$; $V_q = V_o - 6\text{ dB}$;
 $f_r = 599.25\text{ MHz}$; $V_r = V_o - 6\text{ dB}$;
measured at $f_p + f_q - f_r = 588.25\text{ MHz}$.
- The module normally operates at $V_B = 24\text{ V}$, but is able to withstand supply transients up to 30 V.

600 MHz, 18.2 dB gain push-pull amplifier

BGY685A

Table 2 Bandwidth 40 to 550 MHz; $T_{\text{case}} = 30\text{ }^{\circ}\text{C}$; $Z_S = Z_L = 75\text{ }\Omega$

SYMBOL	PARAMETER	CONDITIONS	MIN.	TYP.	MAX.	UNIT
G_p	power gain	$f = 50\text{ MHz}$	17.7	–	18.7	dB
		$f = 550\text{ MHz}$	18.8	–	20	dB
SL	slope cable equivalent	$f = 40\text{ to }550\text{ MHz}$	0.5	–	2	dB
FL	flatness of frequency response	$f = 40\text{ to }550\text{ MHz}$	–	–	± 0.2	dB
S_{11}	input return losses	$f = 40\text{ to }80\text{ MHz}$	20	–	–	dB
		$f = 80\text{ to }160\text{ MHz}$	19	–	–	dB
		$f = 160\text{ to }550\text{ MHz}$	18	–	–	dB
S_{22}	output return losses	$f = 40\text{ to }80\text{ MHz}$	20	–	–	dB
		$f = 80\text{ to }160\text{ MHz}$	19	–	–	dB
		$f = 160\text{ to }550\text{ MHz}$	18	–	–	dB
S_{21}	phase response	$f = 50\text{ MHz}$	–45	–	+45	deg
CTB	composite triple beat	77 channels flat; $V_o = 44\text{ dBmV}$; measured at 547.25 MHz	–	–	–59	dB
X_{mod}	cross modulation	77 channels flat; $V_o = 44\text{ dBmV}$; measured at 55.25 MHz	–	–	–62	dB
CSO	composite second order distortion	77 channels flat; $V_o = 44\text{ dBmV}$; measured at 548.5 MHz	–	–	–59	dB
d_2	second order distortion	note 1	–	–	–72	dB
V_o	output voltage	$d_{\text{im}} = -60\text{ dB}$; note 2	61.5	–	–	dBmV
F	noise figure	$f = 550\text{ MHz}$	–	–	8	dB
I_{tot}	total current consumption (DC)	note 3	–	220	240	mA

Notes

- $f_p = 55.25\text{ MHz}$; $V_p = 44\text{ dBmV}$;
 $f_q = 493.25\text{ MHz}$; $V_q = 44\text{ dBmV}$;
measured at $f_p + f_q = 548.5\text{ MHz}$.
- $f_p = 540.25\text{ MHz}$; $V_p = V_o$;
 $f_q = 547.25\text{ MHz}$; $V_q = V_o - 6\text{ dB}$;
 $f_r = 549.25\text{ MHz}$; $V_r = V_o - 6\text{ dB}$;
measured at $f_p + f_q - f_r = 538.25\text{ MHz}$.
- The module normally operates at $V_B = 24\text{ V}$, but is able to withstand supply transients up to 30 V.

600 MHz, 18.2 dB gain push-pull amplifier

BGY685A

Table 3 Bandwidth 40 to 450 MHz; $T_{\text{case}} = 30\text{ }^{\circ}\text{C}$; $Z_S = Z_L = 75\ \Omega$

SYMBOL	PARAMETER	CONDITIONS	MIN.	TYP.	MAX.	UNIT
G_p	power gain	$f = 50\text{ MHz}$	17.7	–	18.7	dB
		$f = 450\text{ MHz}$	18.6	–	19.8	dB
SL	slope cable equivalent	$f = 40\text{ to }450\text{ MHz}$	0.5	–	1.8	dB
FL	flatness of frequency response	$f = 40\text{ to }450\text{ MHz}$	–	–	± 0.2	dB
S_{11}	input return losses	$f = 40\text{ to }80\text{ MHz}$	20	–	–	dB
		$f = 80\text{ to }160\text{ MHz}$	19	–	–	dB
		$f = 160\text{ to }450\text{ MHz}$	18	–	–	dB
S_{22}	output return losses	$f = 40\text{ to }80\text{ MHz}$	20	–	–	dB
		$f = 80\text{ to }160\text{ MHz}$	19	–	–	dB
		$f = 160\text{ to }450\text{ MHz}$	18	–	–	dB
S_{21}	phase response	$f = 50\text{ MHz}$	–45	–	+45	deg
CTB	composite triple beat	60 channels flat; $V_o = 46\text{ dBmV}$; measured at 445.25 MHz	–	–	–61	dB
X_{mod}	cross modulation	60 channels flat; $V_o = 46\text{ dBmV}$; measured at 55.25 MHz	–	–	–61	dB
CSO	composite second order distortion	60 channels flat; $V_o = 46\text{ dBmV}$; measured at 446.5 MHz	–	–	–61	dB
d_2	second order distortion	note 1	–	–	–75	dB
V_o	output voltage	$d_{\text{im}} = -60\text{ dB}$; note 2	64	–	–	dBmV
F	noise figure	$f = 450\text{ MHz}$	–	–	7	dB
I_{tot}	total current consumption (DC)	note 3	–	220	240	mA

Notes

- $f_p = 55.25\text{ MHz}$; $V_p = 46\text{ dBmV}$;
 $f_q = 391.25\text{ MHz}$; $V_q = 46\text{ dBmV}$;
measured at $f_p + f_q = 446.5\text{ MHz}$.
- $f_p = 440.25\text{ MHz}$; $V_p = V_o$;
 $f_q = 447.25\text{ MHz}$; $V_q = V_o - 6\text{ dB}$;
 $f_r = 449.25\text{ MHz}$; $V_r = V_o - 6\text{ dB}$;
measured at $f_p + f_q - f_r = 438.25\text{ MHz}$.
- The module normally operates at $V_B = 24\text{ V}$, but is able to withstand supply transients up to 30 V.

600 MHz, 18.2 dB gain push-pull amplifier

BGY685A

PACKAGE OUTLINE

Rectangular single-ended package; aluminium flange; 2 vertical mounting holes; 2 x 6-32 UNC and 2 extra horizontal mounting holes; 7 gold-plated in-line leads

SOT115J

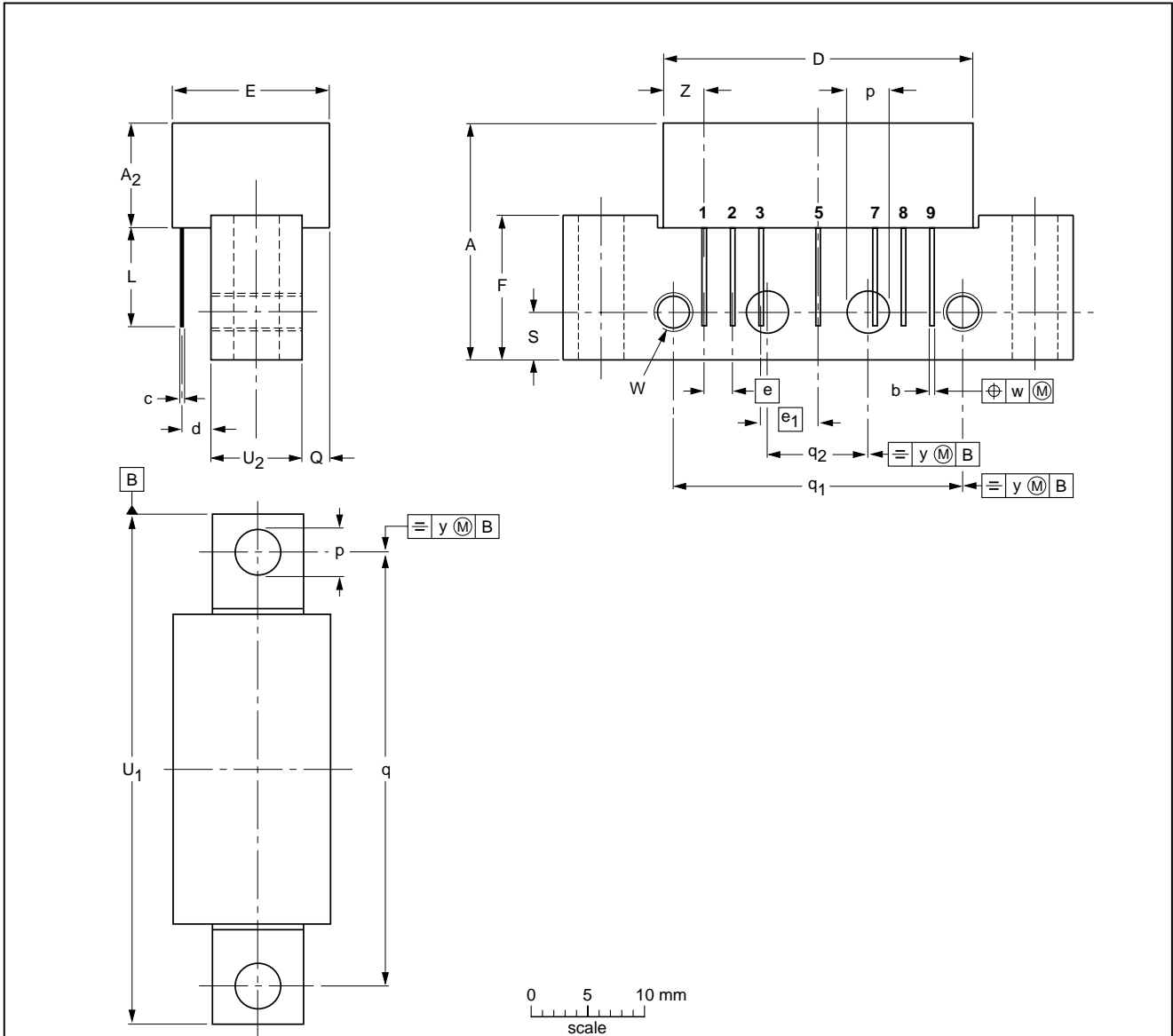

DIMENSIONS (mm are the original dimensions)

UNIT	A max.	A ₂ max.	b	c	D max.	d max.	E max.	e	e ₁	F	L min.	p	Q max.	q	q ₁	q ₂	S	U ₁ max.	U ₂	W	w	y	Z max.
mm	20.8	9.1	0.51 0.38	0.25	27.2	2.54	13.75	2.54	5.08	12.7	8.8	4.15 3.85	2.4	38.1	25.4	10.2	4.2	44.75	8	6-32 UNC	0.25	0.1	3.8

OUTLINE VERSION	REFERENCES				EUROPEAN PROJECTION	ISSUE DATE
	IEC	JEDEC	EIAJ			
SOT115J						99-02-06

600 MHz, 18.2 dB gain push-pull amplifier

BGY685A

DATA SHEET STATUS

DATA SHEET STATUS ⁽¹⁾	PRODUCT STATUS ⁽²⁾	DEFINITIONS
Objective data	Development	This data sheet contains data from the objective specification for product development. Philips Semiconductors reserves the right to change the specification in any manner without notice.
Preliminary data	Qualification	This data sheet contains data from the preliminary specification. Supplementary data will be published at a later date. Philips Semiconductors reserves the right to change the specification without notice, in order to improve the design and supply the best possible product.
Product data	Production	This data sheet contains data from the product specification. Philips Semiconductors reserves the right to make changes at any time in order to improve the design, manufacturing and supply. Changes will be communicated according to the Customer Product/Process Change Notification (CPCN) procedure SNW-SQ-650A.

Notes

1. Please consult the most recently issued data sheet before initiating or completing a design.
2. The product status of the device(s) described in this data sheet may have changed since this data sheet was published. The latest information is available on the Internet at URL <http://www.semiconductors.philips.com>.

DEFINITIONS

Short-form specification — The data in a short-form specification is extracted from a full data sheet with the same type number and title. For detailed information see the relevant data sheet or data handbook.

Limiting values definition — Limiting values given are in accordance with the Absolute Maximum Rating System (IEC 60134). Stress above one or more of the limiting values may cause permanent damage to the device. These are stress ratings only and operation of the device at these or at any other conditions above those given in the Characteristics sections of the specification is not implied. Exposure to limiting values for extended periods may affect device reliability.

Application information — Applications that are described herein for any of these products are for illustrative purposes only. Philips Semiconductors make no representation or warranty that such applications will be suitable for the specified use without further testing or modification.

DISCLAIMERS

Life support applications — These products are not designed for use in life support appliances, devices, or systems where malfunction of these products can reasonably be expected to result in personal injury. Philips Semiconductors customers using or selling these products for use in such applications do so at their own risk and agree to fully indemnify Philips Semiconductors for any damages resulting from such application.

Right to make changes — Philips Semiconductors reserves the right to make changes, without notice, in the products, including circuits, standard cells, and/or software, described or contained herein in order to improve design and/or performance. Philips Semiconductors assumes no responsibility or liability for the use of any of these products, conveys no licence or title under any patent, copyright, or mask work right to these products, and makes no representations or warranties that these products are free from patent, copyright, or mask work right infringement, unless otherwise specified.

Philips Semiconductors – a worldwide company

Contact information

For additional information please visit <http://www.semiconductors.philips.com>. Fax: +31 40 27 24825

For sales offices addresses send e-mail to: sales.addresses@www.semiconductors.philips.com.

© Koninklijke Philips Electronics N.V. 2001

SCA73

All rights are reserved. Reproduction in whole or in part is prohibited without the prior written consent of the copyright owner.

The information presented in this document does not form part of any quotation or contract, is believed to be accurate and reliable and may be changed without notice. No liability will be accepted by the publisher for any consequence of its use. Publication thereof does not convey nor imply any license under patent- or other industrial or intellectual property rights.

Printed in The Netherlands

613518/05/pp8

Date of release: 2001 Oct 22

Document order number: 9397 750 08805

Let's make things better.

**Philips
Semiconductors**



PHILIPS