

PTC Thermistors, For Temperature Protection

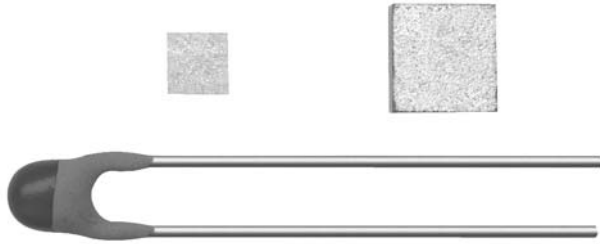

FEATURES

- Well-defined protection temperature levels
- Very fast reaction time
- Accurate resistance for ease of circuit design
- Excellent long term behavior
- Wide range of protection temperatures
- No need to reset supply after overtemperature switch
- Small size and rugged
- Coated leaded and naked devices available.

APPLICATIONS

- Industrial electronics
- Power supplies
- Electronic data processing
- Motor protection.

DESCRIPTION

These directly heated thermistors have a positive temperature coefficient and are primarily intended for sensing.

QUICK REFERENCE DATA

| PARAMETER | VALUE | UNIT |
|--|------------------------------|------|
| Maximum resistance at 25 °C | 120 | Ω |
| Minimum resistance at (T _n + 15) °C | 4000 | Ω |
| Maximum (DC) voltage | 30 | V |
| Temperature range | -20 to (T _n + 15) | °C |
| Weight: | | |
| 91002 to 91014 | ≈0.013 | g |
| 91072 to 91087 | ≈0.003 | g |
| 91102 to 91114 | ≈0.08 | g |
| 91152 to 91164 | ≈0.09 | g |
| Climatic category | 25/125/56 | |

NOMINAL WORKING TEMPERATURES AND ORDERING INFORMATION

| NOMINAL WORKING TEMPERATURE | | | | TYPE/CATALOG NUMBER 2322 | | | | |
|-----------------------------|--|--|---|---------------------------------|-------------------|-----------------|---------------|---------------|
| T _n (°C) | RESISTANCE from -20 °C to T _n -20 °C (Ω) | RESISTANCE at T _n -5 °C (Ω) | RESISTANCE at T _n +5 °C (kΩ) | NAKED CHIP ⁽¹⁾ | | LEADED DEVICE | | |
| | | | | 1.0 × 1.0 (mm) | 1.7 × 1.7 (mm) | NORMAL LEADS | LONG LEADS | COLOR CODE |
| | | | | 671 | 671 | 671 | 671 | |
| 70 | 30 to 250 | 50 to 570 | 0.570 to 50 | 91072 | 91002 | 91102 | 91152 | black |
| 80 | 30 to 250 | 50 to 550 | 1.33 to 50 | 91073 ⁽²⁾ | 91003 | 91103 | 91153 | brown |
| 90 | 30 to 250 | 50 to 550 | 1.33 to 50 | 91074 ⁽²⁾ | 91004 | 91104 | 91154 | red |
| 100 | 30 to 250 | 50 to 550 | 1.33 to 50 | 91075 ⁽²⁾ | 91005 | 91105 | 91155 | orange |
| 110 | 30 to 250 | 50 to 550 | 1.33 to 50 | 91076 | 91006 | 91106 | 91156 | yellow |
| 120 | 30 to 250 | 50 to 550 | 1.33 to 50 | 91077 | 91007 | 91107 | 91157 | green |
| 125 | 30 to 250 | 50 to 550 | 1.33 to 50 | 91078 | – | – | – | – |
| 130 | 30 to 250 | 50 to 550 | 1.33 to 50 | 91079 | 91009 | 91109 | 91159 | blue |
| 135 | 30 to 250 | 50 to 550 | 1.33 to 50 | 91081 | – | – | – | – |
| 140 | 30 to 250 | 50 to 550 | 1.33 to 50 | 91082 | 91012 | 91112 | 91162 | violet |
| 145 | 30 to 250 | 50 to 550 | 1.33 to 50 | 91083 | – | – | – | – |
| 150 | 30 to 250 | 50 to 550 | 1.33 to 50 | 91084 | 91014 | 91114 | 91164 | grey |
| 155 | 30 to 250 | 50 to 550 | 1.33 to 50 | 91085 | – | – | – | – |
| 160 | 30 to 250 | 50 to 550 | 1.33 to 50 | 91086 | 91016 | – | – | – |
| 170 | 30 to 250 | 50 to 550 | 1.33 to 50 | 91087 | 91017 | – | – | – |

Notes

1. Naked chips are packed in a hermetically-sealed alu-plastic bag.
2. Resistance at T_n +5 °C = 0.570 to 50 kΩ.

| ELECTRICAL CHARACTERISTICS | |
|--|---|
| PARAMETER | VALUES |
| Maximum resistance at 25 °C | 120 Ω |
| Maximum resistance at (T _n - 5) °C | see Nominal Working Temperatures and Ordering Information table |
| Minimum resistance at (T _n + 15) °C | 4000 Ω |
| Minimum resistance at (T _n + 5) °C | see Nominal Working Temperatures and Ordering Information table |
| Maximum voltage | 30 V (AC or DC) |

DIMENSIONS in millimeters

| PACKAGING QUANTITIES AND CATALOG NUMBERS | | |
|---|-------|------------------------|
| PACKAGING | | CATALOG NUMBERS |
| SPQ | PQ | 2322 |
| 5000 | 20000 | 671 91002 to 671 91014 |
| 5000 | 20000 | 671 91072 to 671 91087 |
| 500 | 5000 | 671 91102 to 671 91114 |
| 500 | 5000 | 671 91152 to 671 91164 |

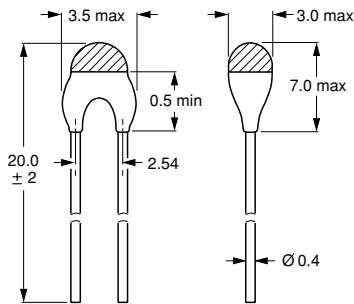
COMPONENT OUTLINES

Component outline for 91102 to 91114.

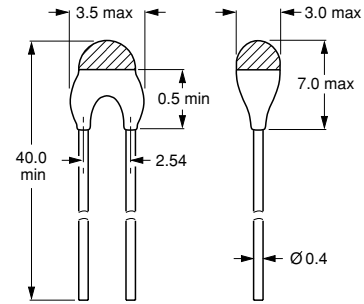

Component outline for 91152 to 91164.

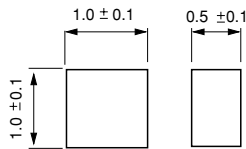

Component outline for 91071 to 91087.

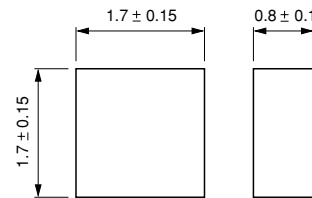

Component outline for 91002 to 91017.

For clamping, reflow or hand soldering. Not intended for either wave or ultrasonic soldering and not for spot welding.
 All standard solder alloys with low activated halogene-free fluxes are acceptable, for example: 62Sn/36Pb/2Ag.

APPLICATION SPECIFIC DATA

Negative Temperature Coefficient (NTC) thermistors are well known for temperature sensing. What is not well known, however, is that Positive Temperature Coefficient (PTC) thermistors can be used for thermal protection. Although their operating principles are similar, the applications are very different; whereas NTC thermistors sense and measure temperature over a defined range, PTC thermistors switch at one particular temperature.

Just like thermostats they protect such equipment and components as motors, transformers, power transistors and thyristors against overtemperature. A PTC thermistor is less expensive than a thermostat, and its switch temperature can be more accurately specified. It is also smaller and easier to design-in to electronic circuitry.

So how does it work? The PTC thermistor is mounted in thermal contact with the equipment to be protected, and connected into the bridge arm of a comparator circuit, such as shown in Fig.1. At normal temperature, the PTC thermistor resistance (R_p) is lower than R_s (see Fig.2), so the comparator's output voltage V_o will be low. If an equipment overtemperature occurs, the PTC thermistor will quickly heat up to its trigger or nominal reference temperature T_n , whereupon its resistance will increase to a value much higher than R_s , causing V_o to switch to a high level sufficient to activate an alarm, relay or power shutdown circuit.

APPLICATION EXAMPLES

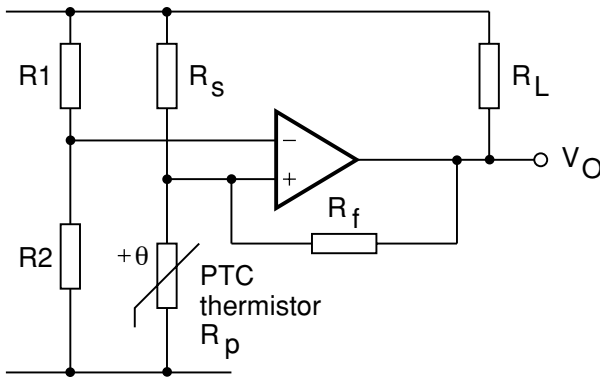

Fig.1 .Typical comparator circuit.

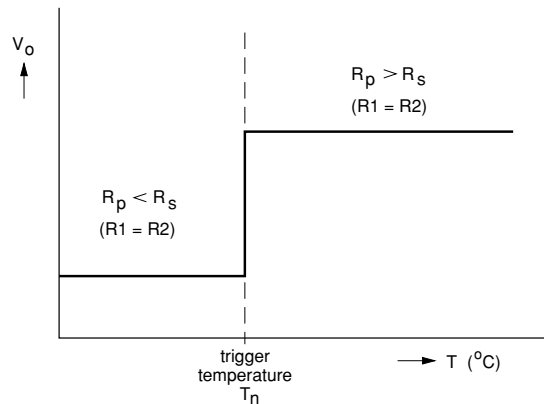
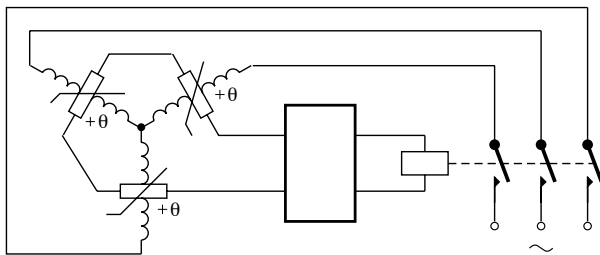
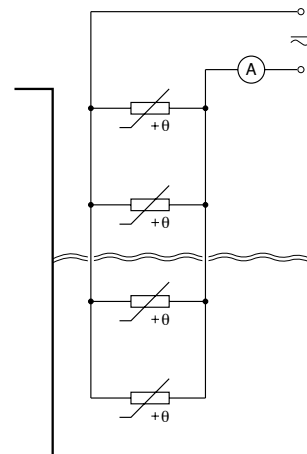

Fig.2 Typical switch characteristic.



As soon as one or more of the windings becomes too hot, the motor is switched off.

Fig.3 Temperature protection of electric motors



The PTC thermistors located above the fluid level will be heated to a temperature greater than T_n . When immersed they are cooled such that their resistance value is reduced.

Fig.4 Liquid-level indication.



TYPICAL RESISTANCE/TEMPERATURE CHARACTERISTIC FOR 2322 671 91052/002/102, 91053/003/103 and 91054/004/104.

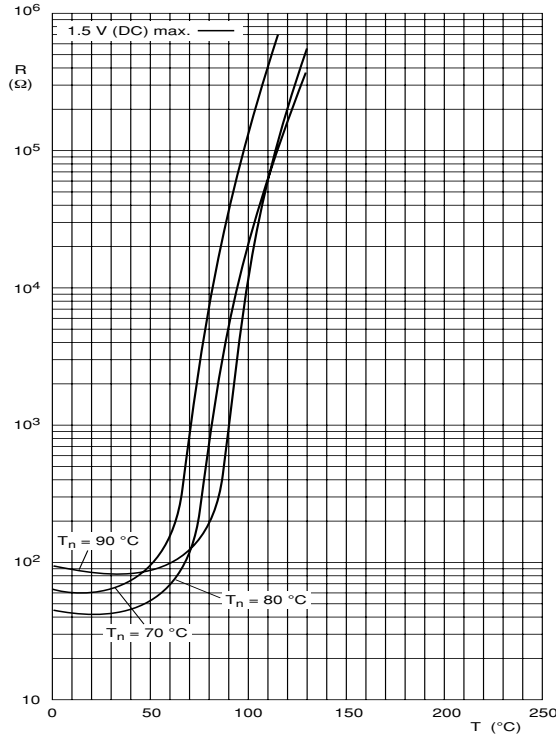

TYPICAL RESISTANCE/TEMPERATURE CHARACTERISTIC FOR 2322 671 91055/005/105, 91056/006/106 and 91057/007/107.

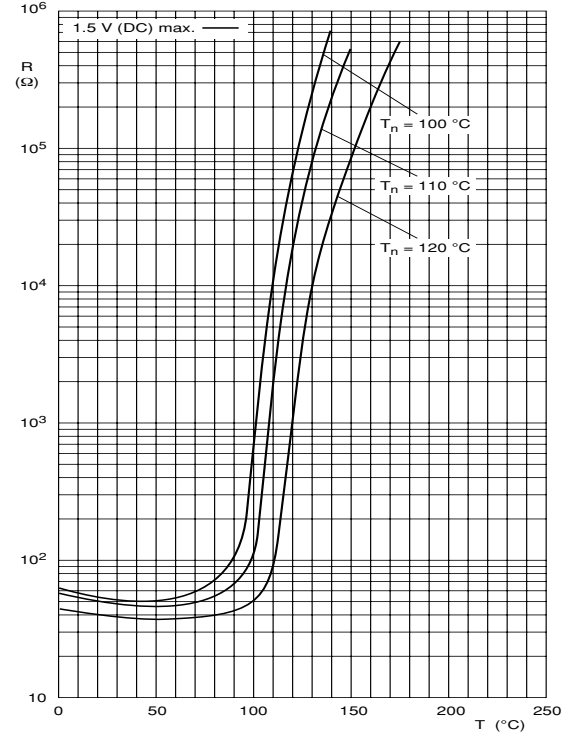

TYPICAL RESISTANCE/TEMPERATURE CHARACTERISTIC FOR 2322 671 91058, 91059/009/109 and 91061.

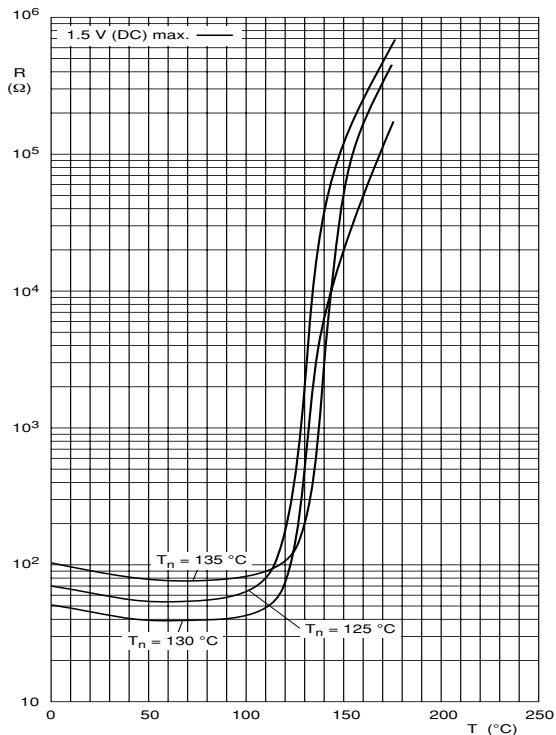

TYPICAL RESISTANCE/TEMPERATURE CHARACTERISTIC FOR 2322 671 91062/012/112, 91063 and 91064/014/114.

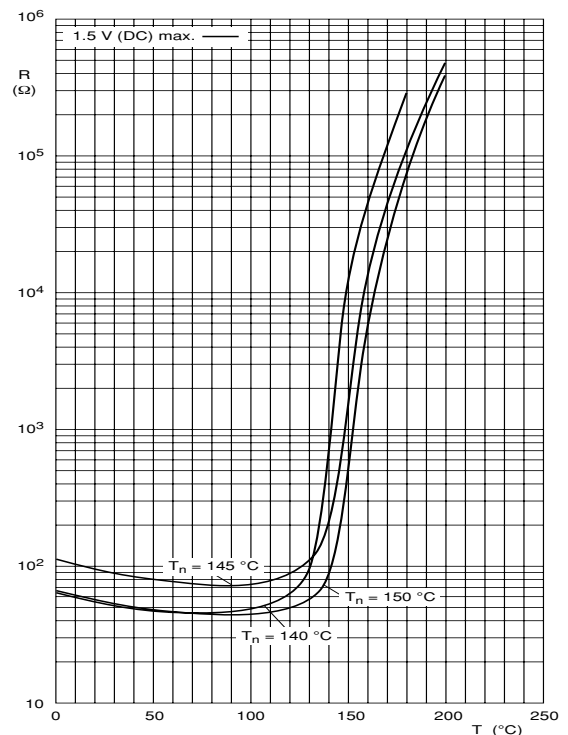



TYPICAL RESISTANCE/TEMPERATURE CHARACTERISTIC FOR 2322 671 91065, 91066 and 91067.

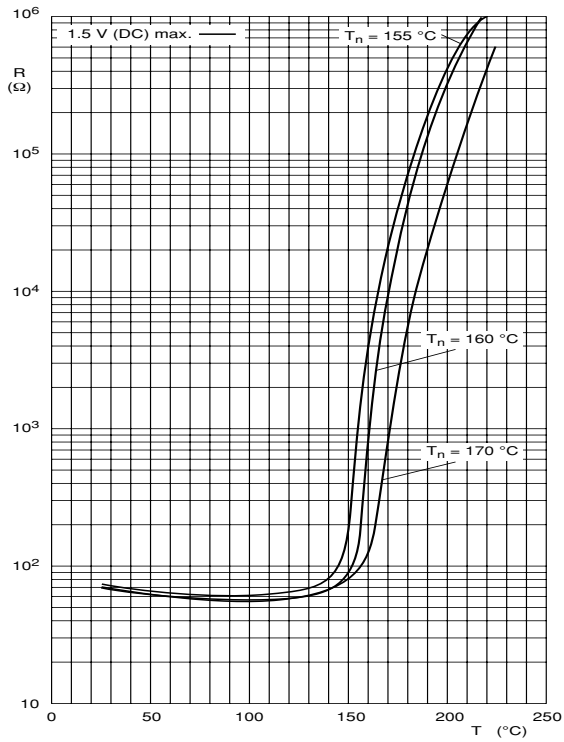

This datasheet has been downloaded from:

www.DatasheetCatalog.com

Datasheets for electronic components.