

## 1/4 TO 1/11-DUTY VFD CONTROLLER/DRIVER

- MANY DISPLAY MODES (11 SEGMENTS & 11 DIGITS TO 16 SEGMENTS & 4 DIGITS)
- KEY SCANNING (6 x 4 MATRIX)
- DIMMING CIRCUIT (EIGHT STEPS)
- HIGH-VOLTAGE OUTPUT ( $V_{DD} - 35V$  MAX)
- LED PORTS (4 CHS, 20mA MAX)
- GENERAL PURPOSE INPUT PORT (4 bits)
- NO EXTERNAL RESISTOR NECESSARY FOR DRIVER OUTPUT (P-CH OPEN DRAIN + PULL DOWN RESISTOR OUTPUT)
- SERIAL INTERFACE (CLK, STB,  $D_{IN}$ ,  $D_{OUT}$ )

### DESCRIPTION

The STM86312 is a VFD (Vacuum Fluorescent Display) controller/driver that is driven on a 1/4 to 1/11-duty factor. It consists of 11-segments output lines, 6 grid output lines, 5 segments/grid output drive lines, a display memory, a control circuit, and a key scan circuit. Serial data are input to the STM86312 through a three-line serial interface.

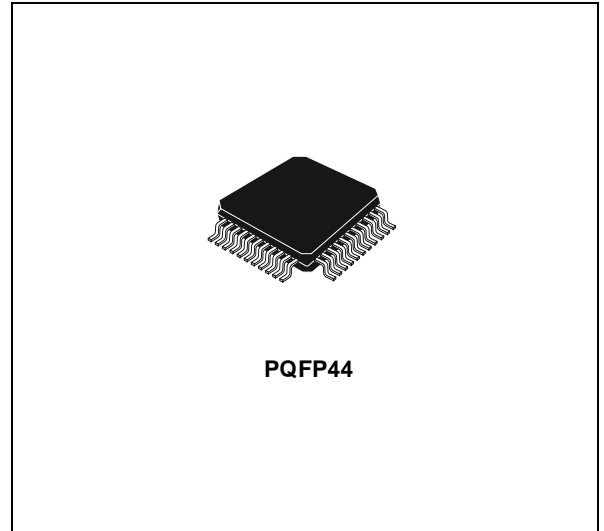

This VFD controller/driver is ideal as a peripheral device for a single-chip microcomputer.

### ORDERING CODES

Type	Temperature Range	Package	Comments
STM86312	-40 to 85 °C	PQFP44	250 parts per Reel

Figure 1: Block Diagram

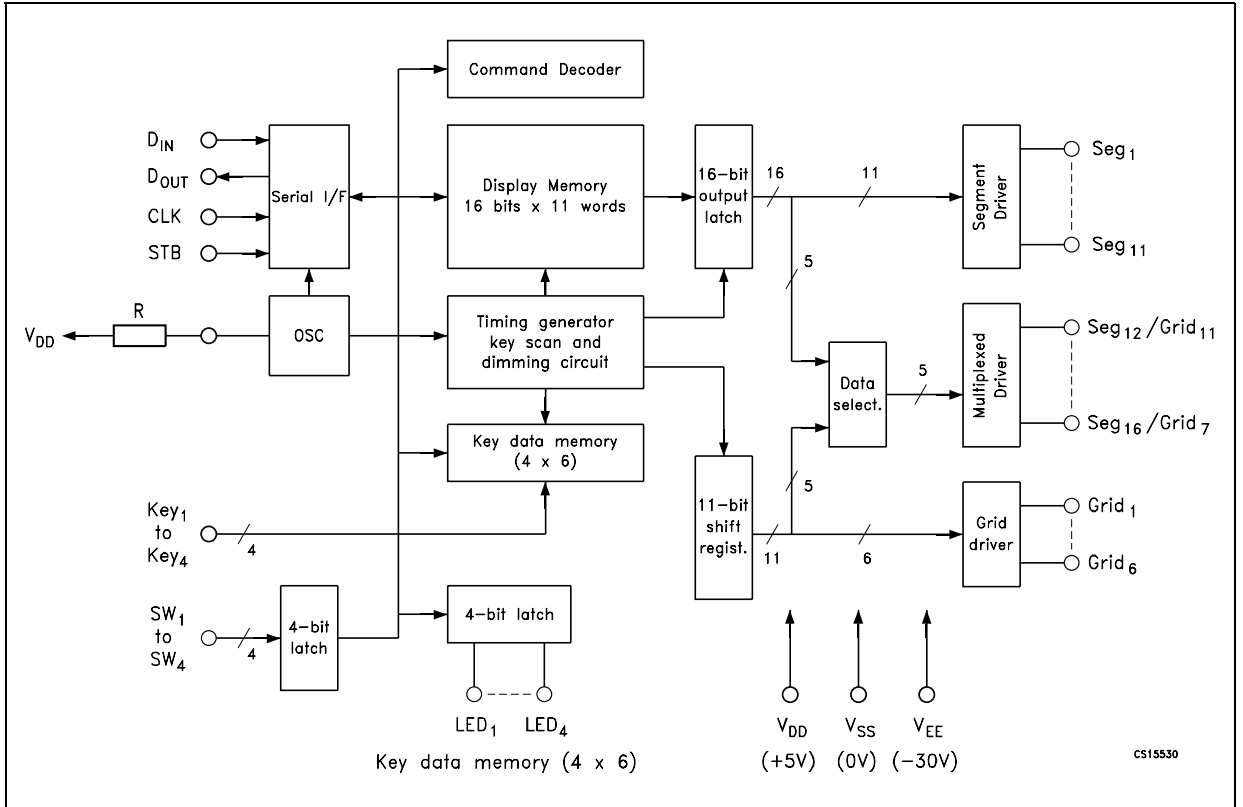

Figure 2: Pin Configuration (TOP VIEW)

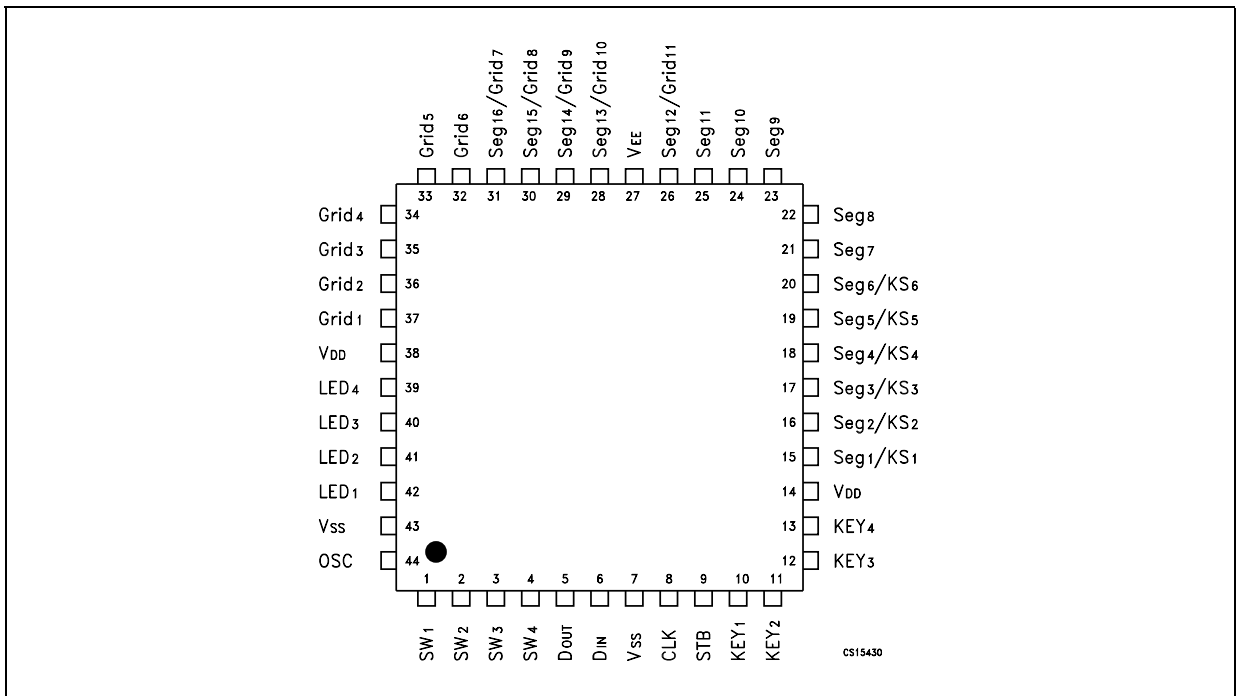

Table 1: Pin Description

PIN N°	SYMBOL	NAME AND FUNCTION
1, 2, 3, 4	SW1, SW2, SW3, SW4	General-purpose switch inputs.
5	D <sub>OUT</sub>	Output serial data at falling edge of the shift clock, starting from lower bit. This is N-ch open-drain output pin.
6	D <sub>IN</sub>	Input serial data at rising edge of the shift clock, starting from lower bit.
8	CLK	Reads serial data at rising edge, and outputs data at falling edge.
9	STB	Initializes serial interface at rising or falling edge to make STM86312 waiting for reception of command. Data input after STB has fallen are processed as a command. While command data are processed, current processing is stopped, and the serial interface is initialized. While STB is high, CLK is ignored.
10, 11, 12, 13	KEY1, KEY2, KEY3, KEY4	Input data to these pins are latched at end of the display cycle.
14, 38	V <sub>DD</sub>	5V ± 10%.
15, 16, 17, 18, 19, 20	SEG1/KS1 to SEG6/KS6	Segment output pins (Dual function as key source).
21, 22, 23, 24, 25	SEG7 to SEG11	Segment output pins.
26, 28, 29, 30, 31	SEG12/GRID11 to SEG16/GRID7	These pins are selectable for segment or grid driving.
32, 33, 34, 35, 36, 37	GRID1 to GRID6	Grid output pins.
39, 40, 41, 42	LED1 to LED4	CMOS outputs. +20 mA max.
7, 43	V <sub>SS</sub>	Connect this pin to system GND.
27	V <sub>EE</sub>	Pull-down level. V <sub>DD</sub> - 35V max.
44	OSC	Connect to an external resistor.

Table 2: Absolute Maximum Ratings (T<sub>A</sub> = 25°C, V<sub>SS</sub> = 0V)

Symbol	Parameter	Value	Unit
V <sub>DD</sub>	Logic Supply Voltage	-0.5 to 7	V
V <sub>EE</sub>	Driver Supply Voltage	V <sub>DD</sub> +0.5 to V <sub>DD</sub> -40	V
V <sub>I</sub>	Logic Input Voltage	-0.5 to V <sub>DD</sub> +0.5	V
V <sub>O2</sub>	VFD Driver Output Voltage	V <sub>EE</sub> -0.5 to V <sub>DD</sub> +0.5	V
I <sub>O1</sub>	LED Driver Output Current	25	mA
I <sub>O2</sub>	VFD Driver Output Current	-40 (Grid)	mA
		-15 (Segment)	
T <sub>A</sub>	Operating Ambient Temperature	-40 to 85	°C

Absolute Maximum Ratings are those values beyond which damage to the device may occur. Functional operation under these condition is not implied.

Table 3: Thermal Data

Symbol	Parameter	Value	Unit
R <sub>Tj-c</sub>	Thermal Resistance Junction-Case	56	°C/W

**Table 4: Recommended Operating Conditions**

Symbol	Parameter	Min	TYP	Max	Unit
V <sub>DD</sub>	Logic Supply Voltage	4.5	5	5.5	V
V <sub>IH</sub>	High Level Input Voltage	0.7xV <sub>DD</sub>		V <sub>DD</sub>	V
V <sub>IL</sub>	Low Level Input Voltage	0		0.3xV <sub>DD</sub>	V
V <sub>EE</sub>	Driver Supply Voltage	0		V <sub>DD</sub> -35	V

Maximum power consumption P<sub>MAX</sub> = VFD driver dissipation + R<sub>L</sub> dissipation + LED driver dissipation + dynamic power consumption.

Where segment current = 3 mA, grid current = 15 mA, and LED current = 20 mA,

VFD driver dissipation = number of segments x 6 + number of grids/(number of grids + 1) x 30 (mW)

R<sub>L</sub> dissipation = (V<sub>DD</sub> - V<sub>EE</sub>)<sup>2</sup>/50 x (segment + 1) (mW)

LED driver dissipation = number of LEDs x 20 (mW)

Dynamic power consumption = V<sub>DD</sub> x 5 (mW)

**Example**

Where V<sub>EE</sub> = -25 V, V<sub>DD</sub> = 5 V, and in 16-segment and 6-digit modes,

VFD driver dissipation = 16 x 6 + 6/7 x 30 = 122

R<sub>L</sub> dissipation = 30<sup>2</sup>/50 x 17 = 306

LED driver dissipation = 4 x 20 = 80

Dynamic power consumption = 5 x 5 = 25

Total 553 mW.

**Table 5: Electrical Characteristics** (V<sub>DD</sub> = 4.5 to 5.5V, V<sub>SS</sub> = 0V, V<sub>EE</sub> = V<sub>DD</sub> - 35V, T<sub>A</sub> = -20 to 70°C, unless otherwise noted. Typical values are at T<sub>A</sub> = 25°C)

Symbol	Parameter	Test Conditions	Value			Unit
			Min.	Typ.	Max.	
V <sub>OH1</sub>	High Level Output Voltage	LED1-LED4, I <sub>OH1</sub> =-1mA	0.9V <sub>DD</sub>			V
V <sub>OL1</sub>	Low Level Output Voltage	LED1-LED4, I <sub>OL1</sub> =20mA			1	V
V <sub>OL2</sub>	Low Level Output Voltage	D <sub>OUT</sub> , I <sub>OL2</sub> = 4mA			0.4	V
I <sub>OH21</sub>	High Level Output Current	V <sub>O</sub> = V <sub>DD</sub> - 2V, Seg1 to Seg11	-3			mA
I <sub>OH22</sub>	High Level Output Current	V <sub>O</sub> = V <sub>DD</sub> - 2V, Grid1 to Grid6, Seg12/Grid11 to Seg16/Grid7	-15			mA
I <sub>OLEAK</sub>	Driver Leakage Current	V <sub>O</sub> = V <sub>DD</sub> - 35V, driver off			-10	μA
R <sub>L</sub>	Output Pull-Down Resistor	Driver Output	50	100	150	kΩ
I <sub>I</sub>	Input Current	V <sub>I</sub> = V <sub>DD</sub> or V <sub>SS</sub>			±1	μA
V <sub>IH</sub>	High Level Input Voltage		0.7V <sub>DD</sub>			V
V <sub>IL</sub>	Low Level Input Voltage				0.3V <sub>DD</sub>	V
V <sub>HYS</sub>	Hysteresis Voltage	CLK, D <sub>IN</sub> , STB		0.35		V
I <sub>DDdyn</sub>	Dynamic Current Consumption	Under no load, display off			5	mA

**Table 6: Switching Characteristics** ( $V_{DD} = 4.5$  to  $5.5V$ ,  $V_{SS} = 0V$ ,  $V_{EE} = V_{DD} - 35V$ ,  $T_A = -20$  to  $70^\circ C$ , unless otherwise noted. Typical values are at  $T_A = 25^\circ C$ )

Symbol	Parameter	Test Conditions	Value			Unit
			Min.	Typ.	Max.	
$t_{PLZ}$	Propagation Delay	CLK $\rightarrow$ D <sub>OUT</sub> $R_L = 10\text{ k}\Omega$ , $C_L = 15\text{ pF}$			300	ns
$t_{PZL}$					100	
$t_{TZH1}$	Rise Time	$C_L = 300\text{ pF}$ Seg1 to Seg11			2	$\mu s$
$t_{TZH2}$			Grid1 to Grid6, Seg12/ Grid11 to Seg16/Grid7			
$t_{THZ}$	Fall Time	$C_L = 300\text{ pF}$ , Segn, Gridn			120	$\mu s$
$f_{MAX}$	Maximum Clock Frequency	Duty = 50%	1			MHz
$C_I$	Input Capacitance				15	pF

**Table 7: Timing Characteristics** ( $V_{DD} = 4.5$  to  $5.5V$ ,  $T_A = -20$  to  $70^\circ C$ , unless otherwise noted. Typical values are at  $T_A = 25^\circ C$ )

Symbol	Parameter	Test Conditions	Value			Unit
			Min.	Typ.	Max.	
$PW_{CLK}$	Clock Pulse Width		400			ns
$PW_{STB}$	Strobe Pulse Width		1			$\mu s$
$t_{SETUP}$	Data Setup Time		100			ns
$t_{HOLD}$	Data Hold Time		100			ns
$t_{CLK-STB}$	Clock-Strobe Time	CLK $\uparrow$ $\rightarrow$ STB $\uparrow$	1			$\mu s$
$t_{WAIT}$	Wait Time (Note 1)	CLK $\uparrow$ $\rightarrow$ CLK $\downarrow$	1			$\mu s$

NOTE 1: Refer to page Serial Communication Format.

## DISPLAY RAM ADDRESS AND DISPLAY MODE

The display RAM stores the data transmitted from an external device to the STM86312 through the serial interface; addresses are as follows, in 8-bits unit:

Seg1	Seg4	Seg8	Seg12	Seg16	
00 H <sub>L</sub>	00 H <sub>U</sub>	01 H <sub>L</sub>	01 H <sub>U</sub>		<b>DIG1</b>
02 H <sub>L</sub>	02 H <sub>U</sub>	03 H <sub>L</sub>	03 H <sub>U</sub>		<b>DIG2</b>
04 H <sub>L</sub>	04 H <sub>U</sub>	05 H <sub>L</sub>	05 H <sub>U</sub>		<b>DIG3</b>
06 H <sub>L</sub>	06 H <sub>U</sub>	07 H <sub>L</sub>	07 H <sub>U</sub>		<b>DIG4</b>
08 H <sub>L</sub>	08 H <sub>U</sub>	09 H <sub>L</sub>	09 H <sub>U</sub>		<b>DIG5</b>
0A H <sub>L</sub>	0A H <sub>U</sub>	0B H <sub>L</sub>	0B H <sub>U</sub>		<b>DIG6</b>
0C H <sub>L</sub>	0C H <sub>U</sub>	0D H <sub>L</sub>	0D H <sub>U</sub>		<b>DIG7</b>
0E H <sub>L</sub>	0E H <sub>U</sub>	0F H <sub>L</sub>	0F H <sub>U</sub>		<b>DIG8</b>
10 H <sub>L</sub>	10 H <sub>U</sub>	11 H <sub>L</sub>	11 H <sub>U</sub>		<b>DIG9</b>
12 H <sub>L</sub>	12 H <sub>U</sub>	13 H <sub>L</sub>	13 H <sub>U</sub>		<b>DIG10</b>
14 H <sub>L</sub>	14 H <sub>U</sub>	15 H <sub>L</sub>	15 H <sub>U</sub>		<b>DIG11</b>

b0	b3 b4	b7
XX H <sub>L</sub>		XX H <sub>U</sub>

"0" in memory means  $V_{EE}$  on output; "1" in memory means  $V_{DD}$  on output.

**Figure 3: Key Matrix And Key-input Data Storage Ram**

The key matrix is of 6 x 4 configuration, as shown below

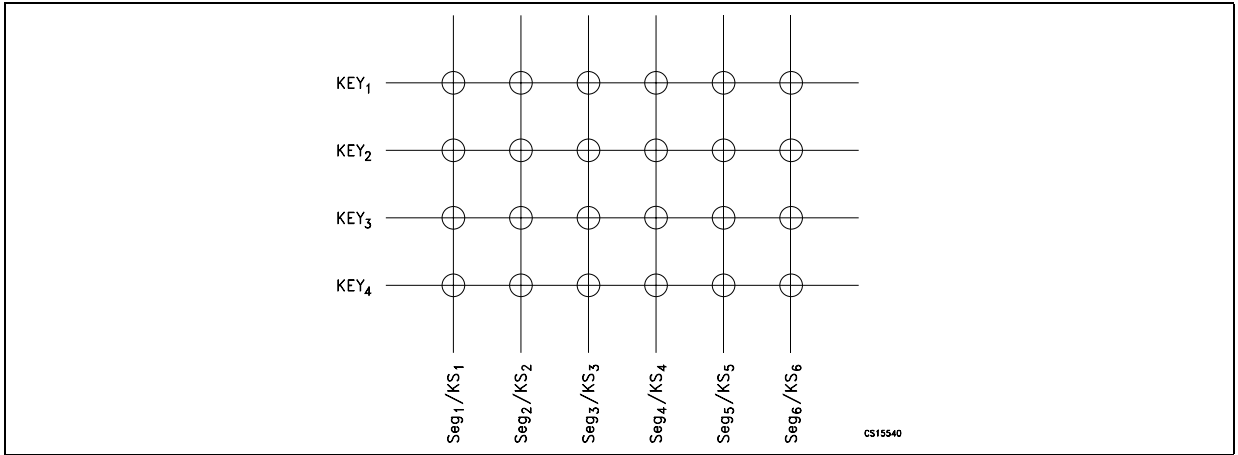

The data of each key are stored as illustrated below, and are read by the appropriate read command, starting from the least significant bit

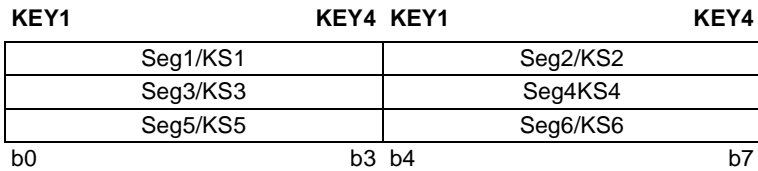

**LED PORT**

Data are written to the LED port by a write command, starting from the least significant bit of the port. When a bit of this port is 0, the corresponding LED lights; when the bit is 1, the LED goes off. The data of bits 5 through 8 are ignored.

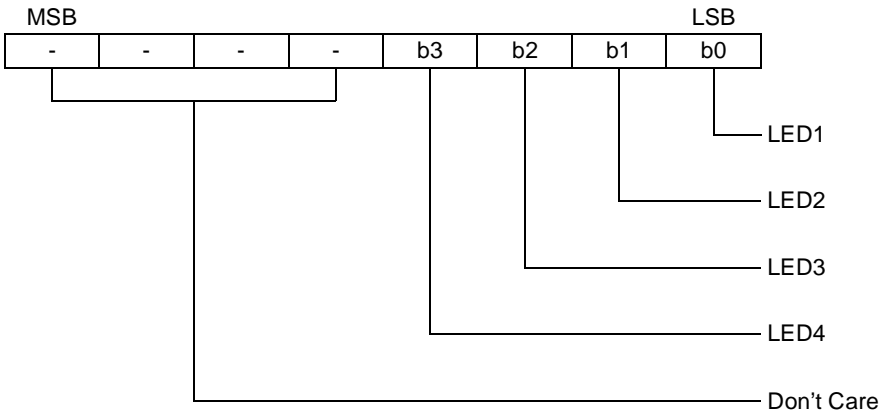

On power application, all the LEDs remain dark.

## SW DATA

The SW data are read by the appropriate read command, starting from the least significant bit. Bits 5 through 8 of the SW data are 0.

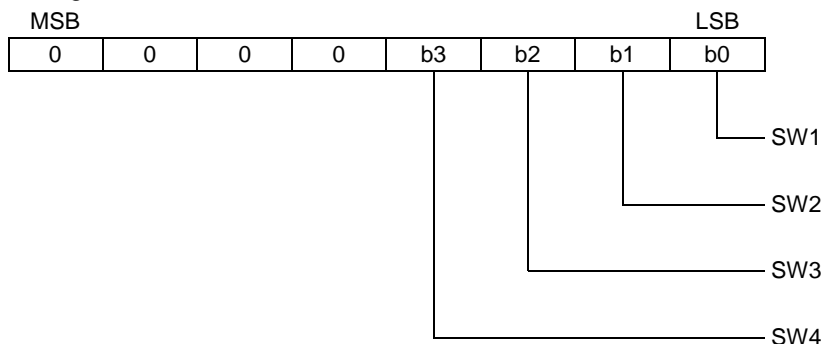

## COMMANDS

A command sets the display mode and status of the VFD driver.

The first 1 byte input to the STM86312 through the  $D_{IN}$  pin after the STB pin has fallen is regarded as a command. If STB is set high while commands/data are transmitted, serial communication is initialized, and the commands/data being transmitted are invalid (however, the commands/data already transmitted remain valid).

### (1) DISPLAY MODE SETTING COMMAND

This command initializes the STM86312 and selects the number of segments and number of grids (1/4 to 1/11 duty, 11 segments to 16 segments).

When this command is executed, display is forcibly turned off, and key scanning is also stopped. To resume display, the display ON command must be executed. If the same mode is selected, however, nothing is performed.

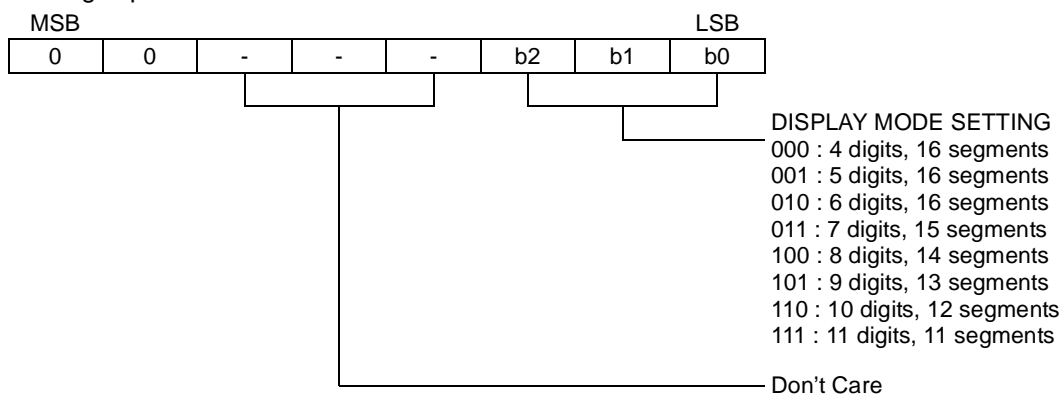

On power application, the 11-digit 11-segment mode is selected.

**(2) DATA SETTING COMMAND**

This command sets data write and data read modes.

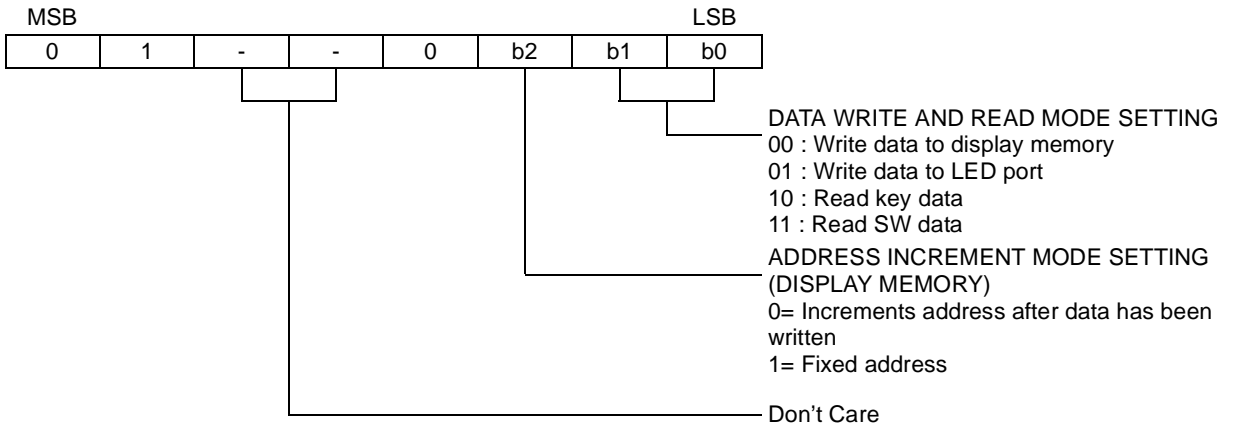

On power application, the normal operation mode and address increment mode are set. Do not use STM86312 in test mode.

**(3) ADDRESS SETTING COMMAND**

This command sets an address of the display memory

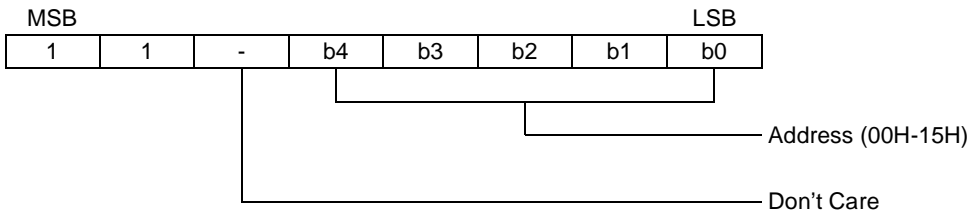

If address 16H or higher is set, the data are ignored, until a correct address is set. On power application, the address is set to 00H.

**(4) DISPLAY CONTROL COMMAND**

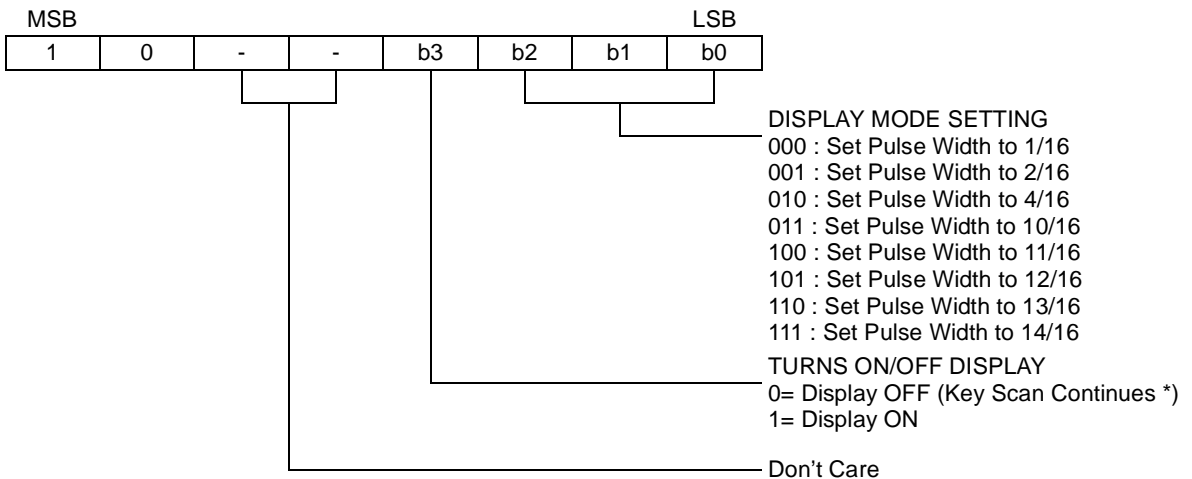

On power application, the 1/16-pulse width is set and the display is turned off.

\*: On power application, key scanning is stopped.



Figure 4: Key Scanning And Display Timing

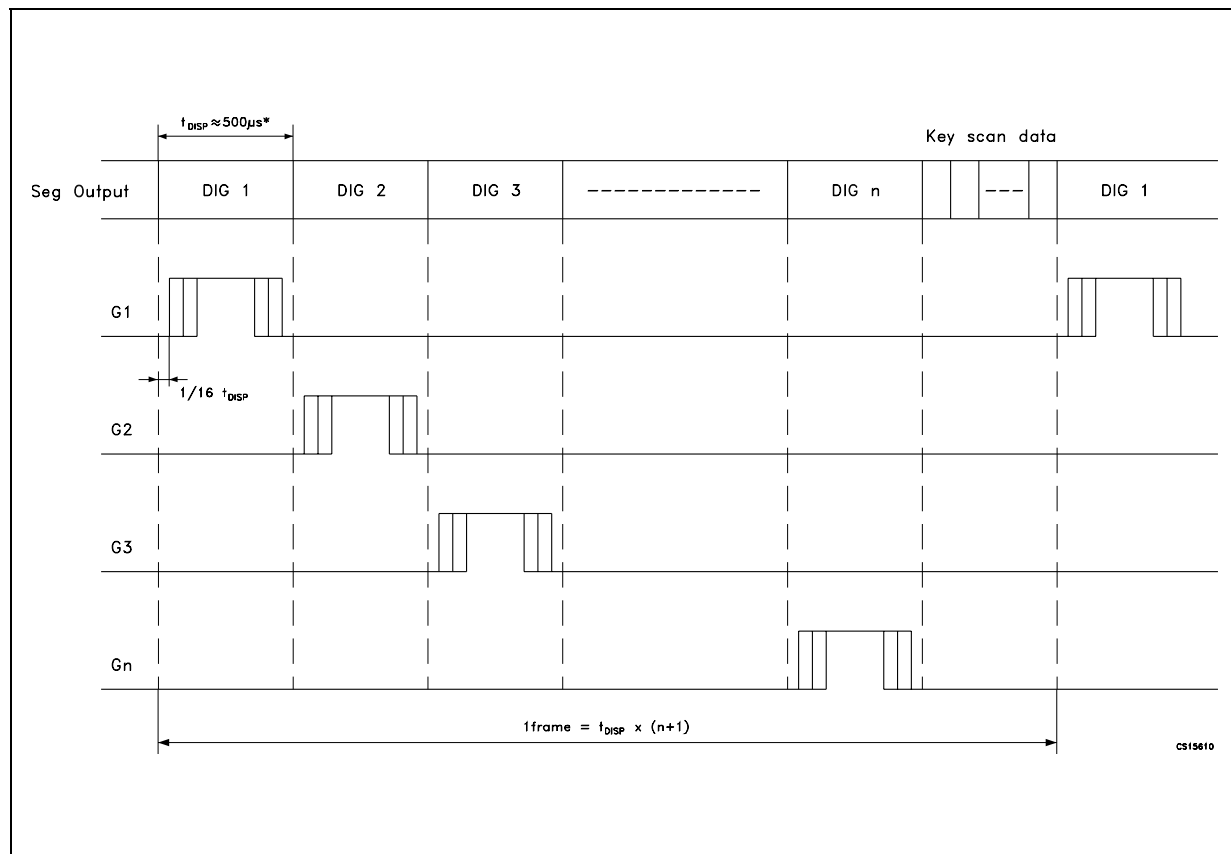

\* The value can be modified by trimming  $R_{OSC}$ .

One cycle of key scanning consists of one frame, and data of 6 x 4 matrices are stored in RAM.

**SERIAL COMMUNICATION FORMAT**

Figure 5: Reception (command/data write)

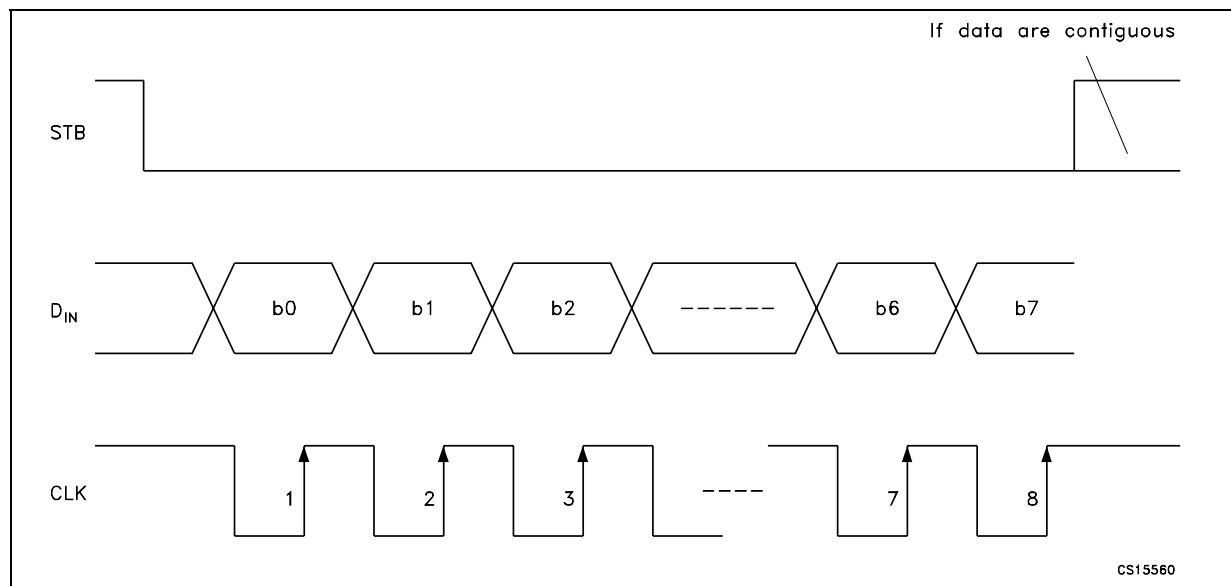
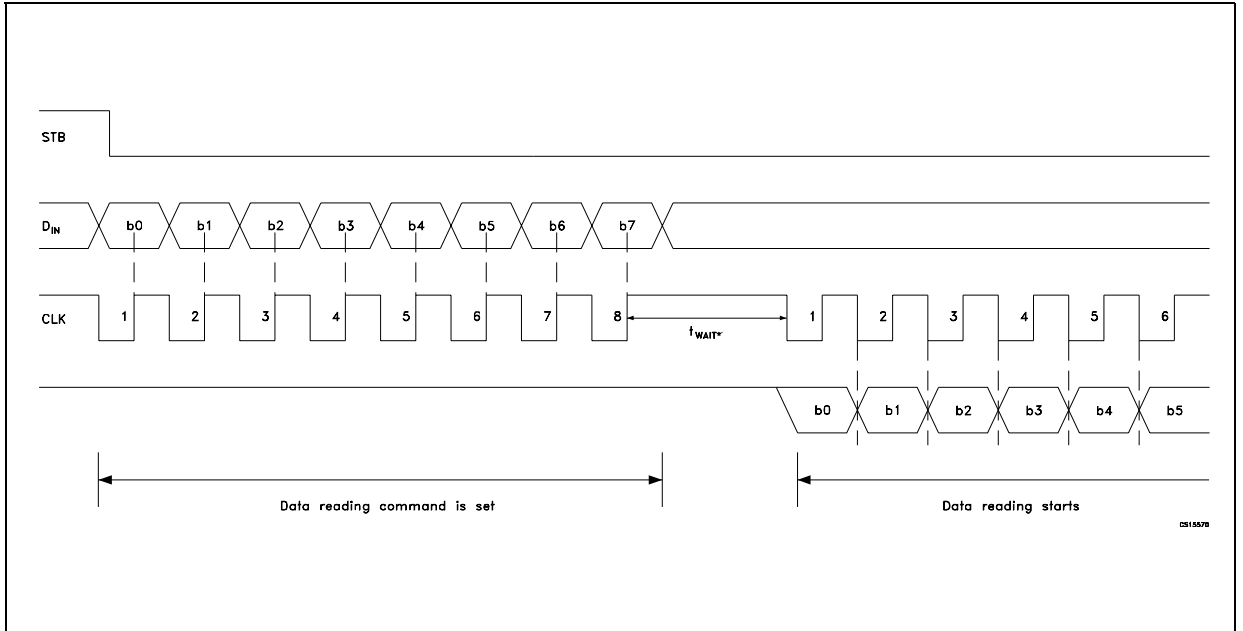

Figure 6: Transmission (data read)



Because the D<sub>OUT</sub> pin is an N-ch open-drain output pin, be sure to connect an external pull-up resistor to this pin (1 kΩ to 10 kΩ).

\*: When data are read, a wait time  $t_{WAIT}$  of 1μs is necessary within the rising edge of the eighth clock that has set the command and the falling one of the first clock that has read the data.

Figure 7: Switching Characteristics Waveform

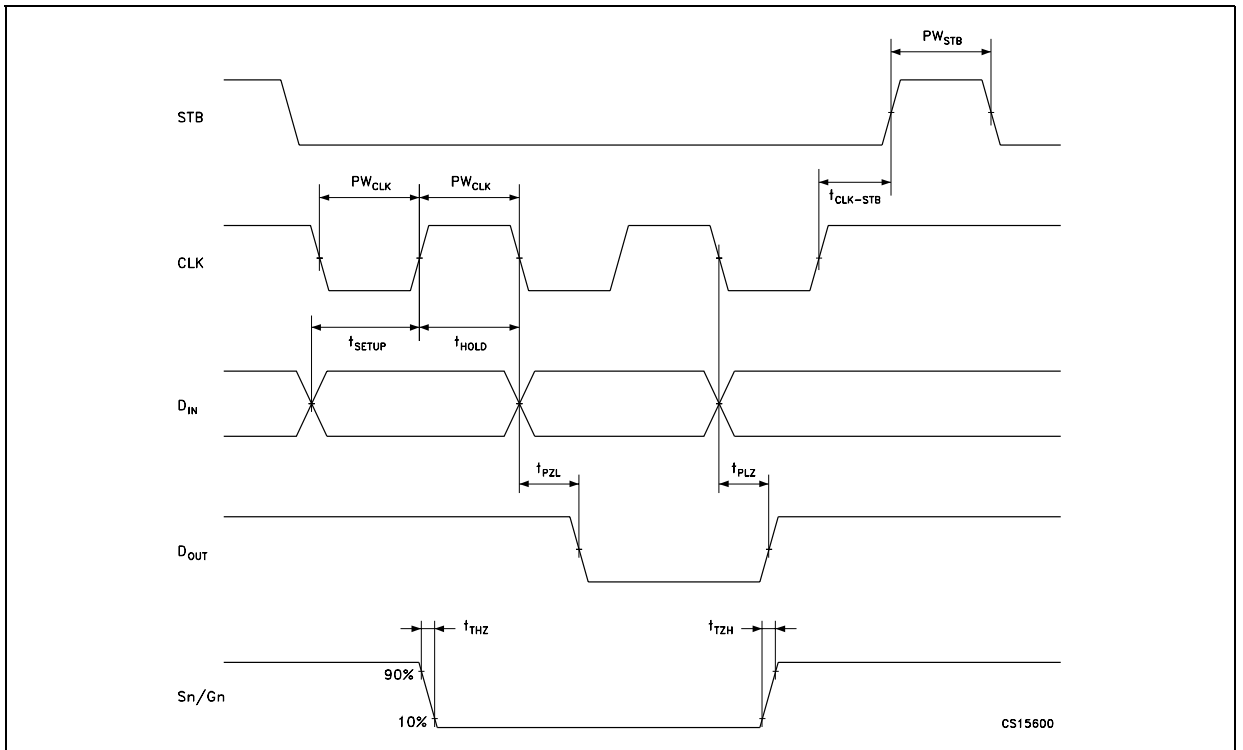

## APPLICATION

Figure 8: Updating display memory by incrementing address

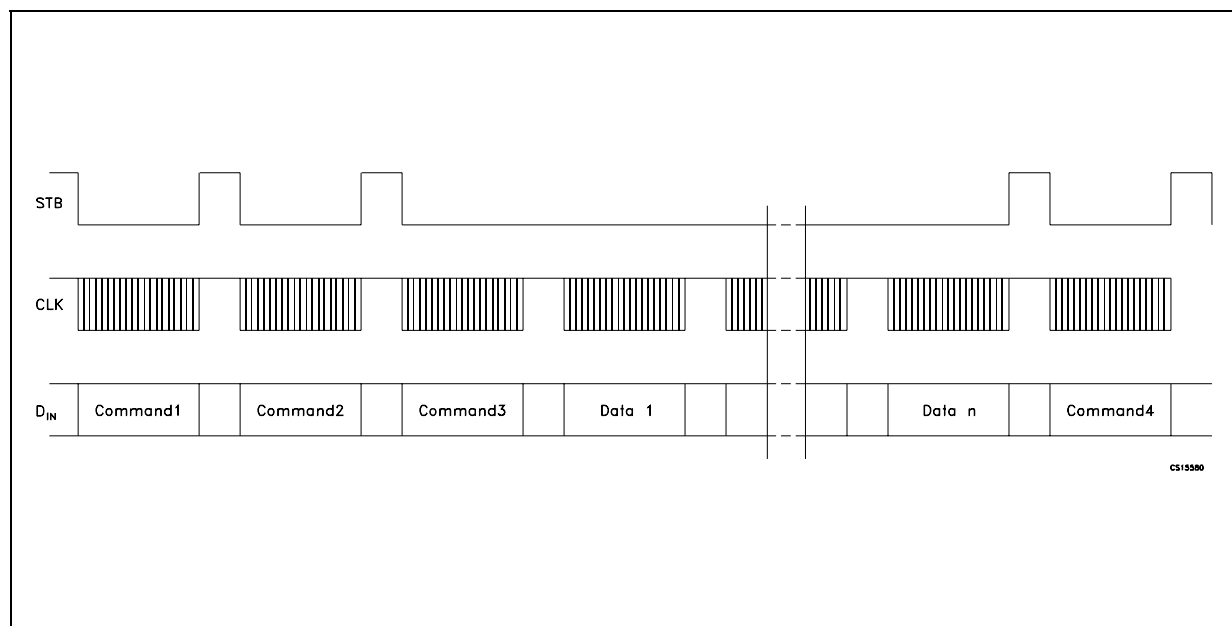

Command 1: sets display mode

Command 2: sets data

Command 3: sets address

Data 1 to n: transfers display data (22 bytes max.)

Command 4: controls display

Figure 9: Updating specific address

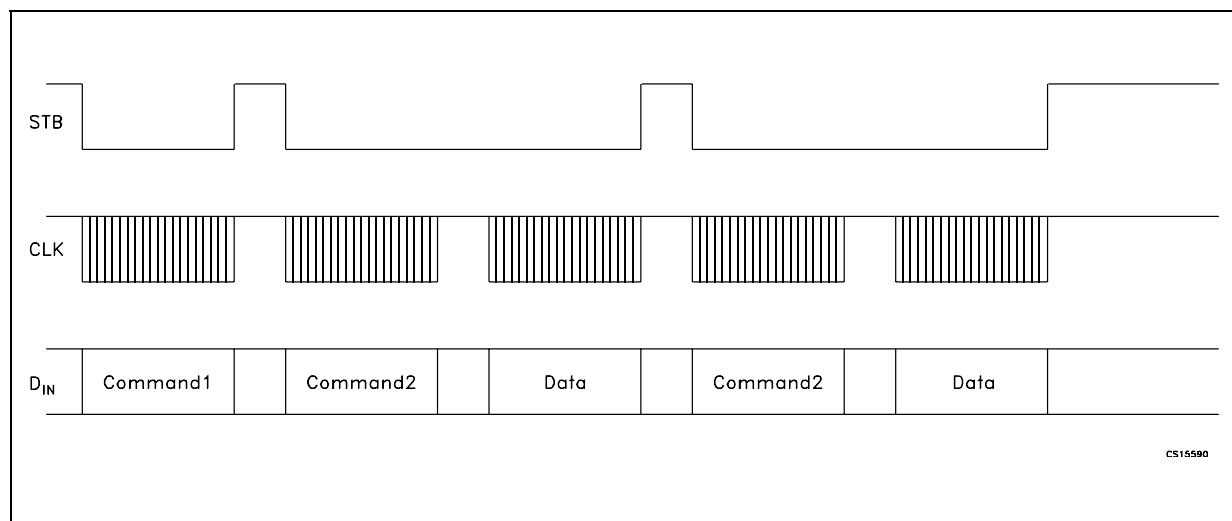

Command 1: sets data

Command 2: sets address

Data: display data

Figure 10: Application Circuit

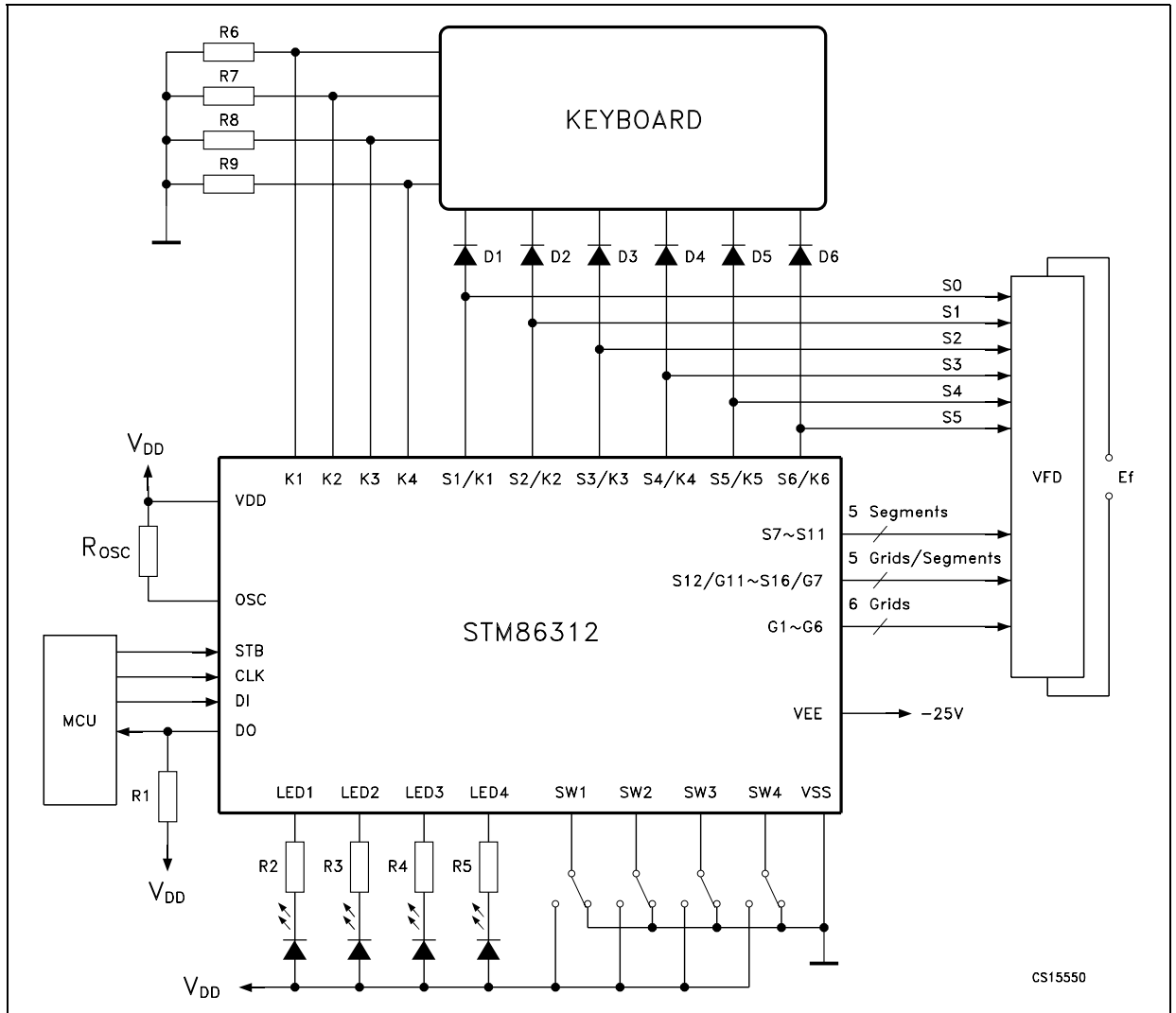

Note:  $R_{OSC} = 47k\Omega$  for oscillator resistor  
 $R1 = 1\sim 10 k\Omega$  for external pull-high resistor  
 $R2\sim R5 = 750\Omega\sim 1.2 k\Omega$   
 $R6\sim R9 = 10k\Omega$  for external pull-low resistor  
 $D1\sim D6 = 1N4001$   
 $Ef$  = Filament voltage for VFD.

## PQFP44 MECHANICAL DATA

DIM.	mm.			inch		
	MIN.	TYP.	MAX.	MIN.	TYP.	MAX.
A			2.45			0.096
A1			0.25			0.010
A2	1.80	2.00	2.20	0.071	0.079	0.087
b	0.29		0.45	0.011		0.018
c	0.11		0.23	0.004		0.009
D		13.2			0.520	
D1		10.00			0.394	
D3		8.00			0.315	
E		13.2			0.520	
E1		10.00			0.394	
E3		8.00			0.315	
e		0.80			0.031	
L	0.73	0.88	1.03	0.029	0.035	0.041
L1		1.6			0.063	
K	0°	3.5°	7°	0°	3.5°	7°

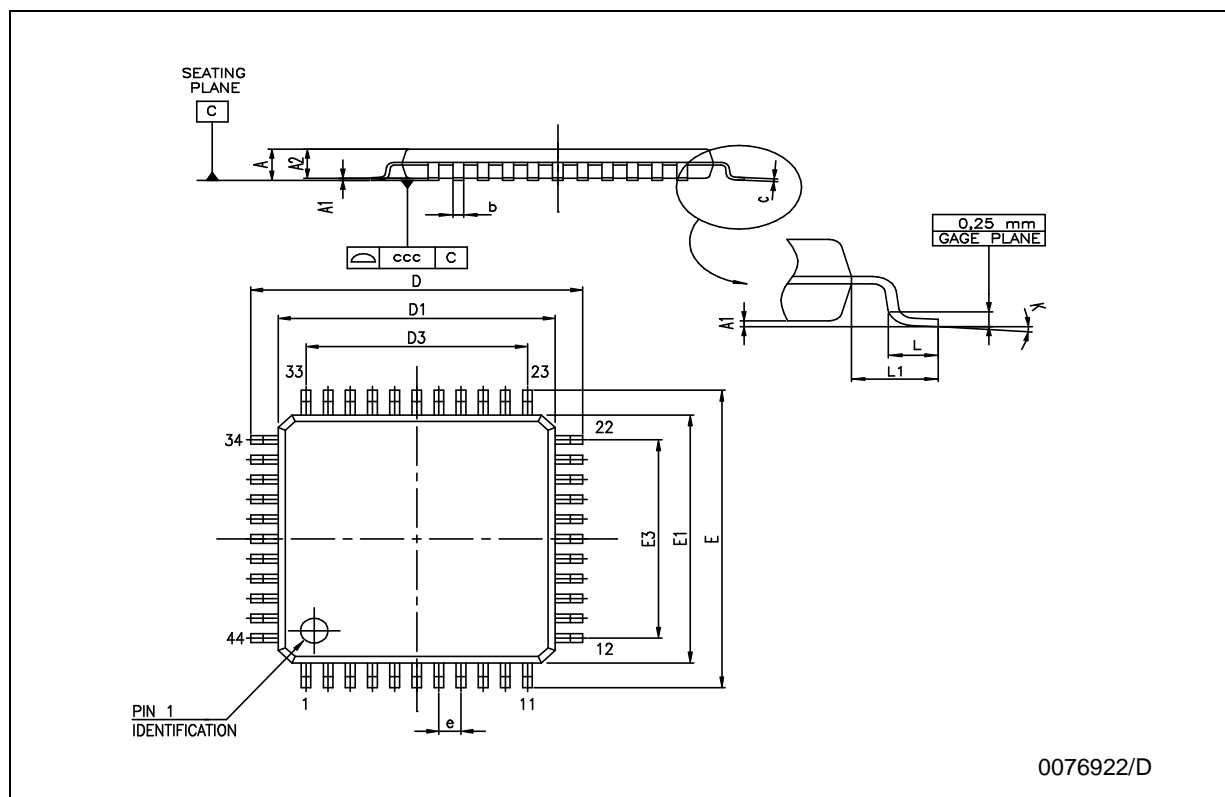

## Tape & Reel PQFP44 MECHANICAL DATA

DIM.	mm.			inch		
	MIN.	TYP	MAX.	MIN.	TYP.	MAX.
A			330			12.992
C	12.8		13.2	0.504		0.519
D	20.2			0.795		
N	60			2.362		
T			30.4			1.196
Ao	12.25		12.45	0482		0.490
Bo	12.25		12.45	0482		0.490
Ko	2.1		2.3	0.083		0.091
Po	3.9		4.1	0.153		0.161
P	15.9		16.1	0.626		0.639

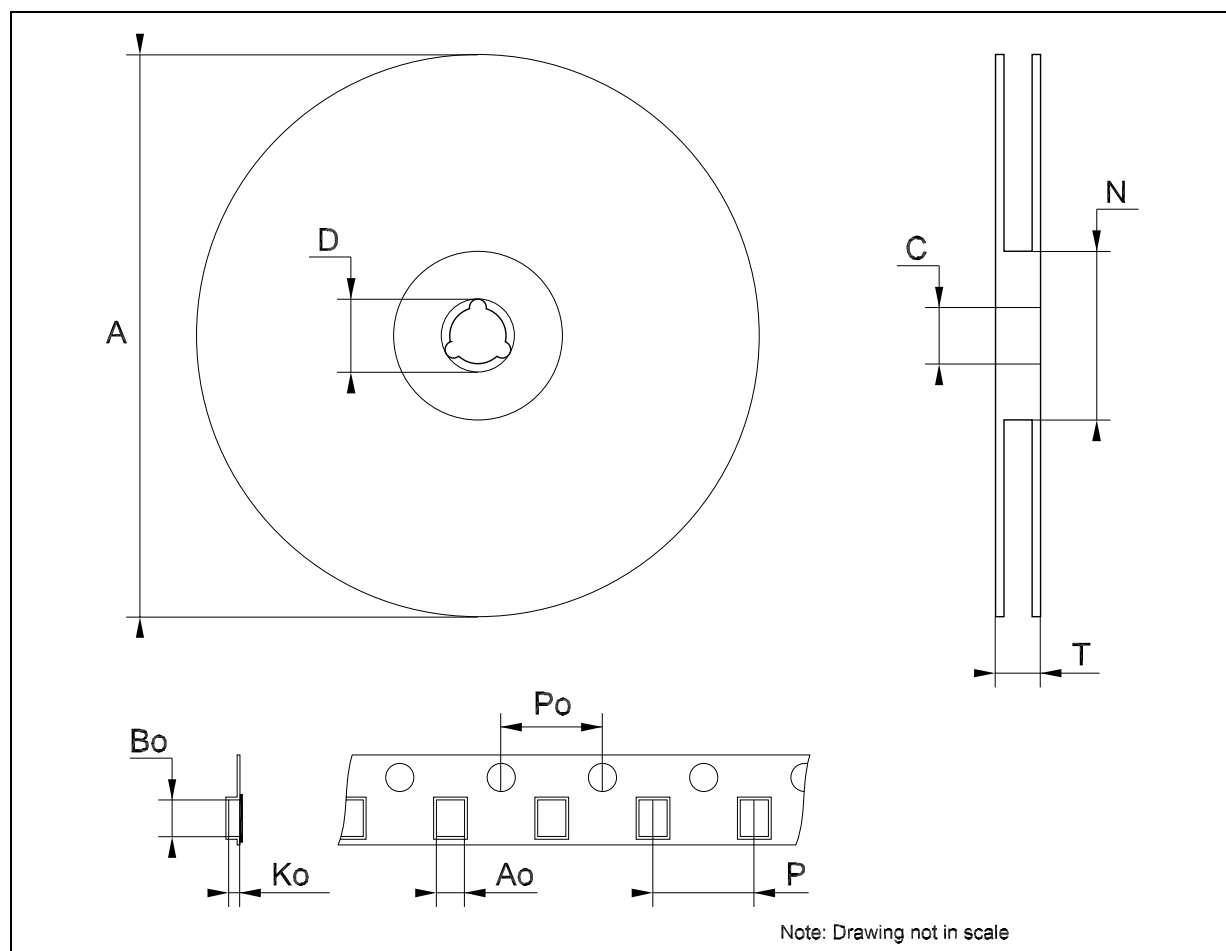

**Table 8: Revision History**

Date	Revision	Description of Changes
27-May-2004	1	First Release

Information furnished is believed to be accurate and reliable. However, STMicroelectronics assumes no responsibility for the consequences of use of such information nor for any infringement of patents or other rights of third parties which may result from its use. No license is granted by implication or otherwise under any patent or patent rights of STMicroelectronics. Specifications mentioned in this publication are subject to change without notice. This publication supersedes and replaces all information previously supplied. STMicroelectronics products are not authorized for use as critical components in life support devices or systems without express written approval of STMicroelectronics.

The ST logo is a registered trademark of STMicroelectronics  
All other names are the property of their respective owners

© 2004 STMicroelectronics - All Rights Reserved  
STMicroelectronics GROUP OF COMPANIES

Australia - Belgium - Brazil - Canada - China - Czech Republic - Finland - France - Germany - Hong Kong - India - Israel - Italy - Japan -  
Malaysia - Malta - Morocco - Singapore - Spain - Sweden - Switzerland - United Kingdom - United States.

<http://www.st.com>