

BOURNS®

OPTICAL INCREMENTAL ENCODERS

- Two channel quadrature output
- Square wave signal
- Small size
- CMOS and TTL compatible
- Long life
- High operating speed
- Bushing or servo mount
- Index channel available
- Resolution to 256PPR

Rotary Optical Encoders

Bourns[®] Optical Encoders

Electrical Characteristics

Output	2-bit gray code, Channel A leads Channel B by 90° (electrical) with clockwise rotation
Supply Voltage	5.0 VDC ±0.25 VDC*
Supply Current	26 mA maximum
Output Voltage	
Low Output	0.8V maximum
High Output	4V minimum
Output Current	
Low Output	25mA minimum
Insulation Resistance (500 VDC)	1,000 megohms
Rise/Fall Time	200ns (typical)
Shaft RPM (Ball Bearing)	3,000 rpm maximum
Power Consumption	136 mW maximum
Pulse Width (Electrical Degrees, Each Channel)	180° ±45° TYP.
Pulse Width (Index Channel)	360° ±90°
Phase (Electrical Degrees, Channel A to Channel B)	90° ±45° TYP.
Index Channel Centered on 1-1 State Combination of A and B Channels	0° ±45°

*Consult factory for other voltages up to 15 VDC.

Environmental Characteristics

Operating Temperature Range (Standard)	-40°C to +85°C
Vibration	5G
Shock	50G
Humidity	MIL-STD-202, Method 103B, Condition B

Mechanical Characteristics

Torque (Starting and Running)	
A & C Bushings (Spring Loaded for Optimum Feel)	1.5 oz-in. maximum
W, S & T Bushings (Ball Bearing Shaft Support)	0.1 oz-in. maximum
Mechanical Rotation	Continuous
Shaft End Play	0.012" T.I.R. maximum
Shaft Radial Play	0.005" T.I.R. maximum
Rotational Life	
A & C Bushings (300 rpm maximum)**	10,000,000 revolutions
W, S & T Bushings (3,000 rpm maximum)**	200,000,000 revolutions
Weight	0.4 oz.

**For resolutions ≤ 128 quadrature cycles per shaft revolution.

OUTPUT TABLE

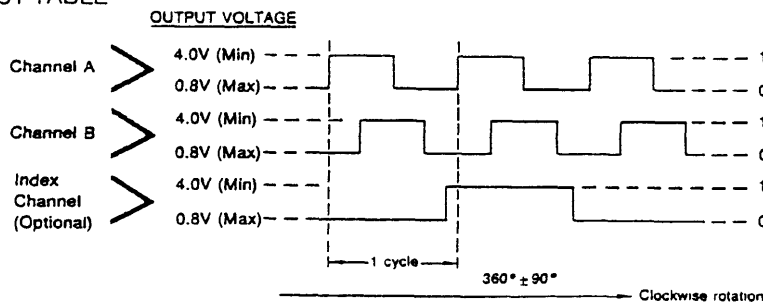

STANDARD RESOLUTIONS AVAILABLE

(Full quadrature output cycles per shaft revolution)	
25°	128
50°	200
64	256
100	

For Non-Standard Resolutions--
Consult Factory

* Channel B leads Channel A

Specifications are subject to change without notice.

107=100 to 107-102

DIGITAL CONTACTING

The Digital Contacting Encoder is commonly referred to by such names as Digital Panel Control, Bit Switch, Gray Switch and Digital Switch. All such names are synonymous with a device whose output is a digital gray code signal, rather than a conventional potentiometric voltage ratio output.

The advantage of the Digital Contacting Encoder is that it permits the direct entry of digitized analog data into a digital circuit without A/D

conversion. The two (2) channel gray coded signal of this incremental encoder allows the user's decoder circuit to sense analog direction of rotation, as well as up-down counter capabilities... all without the time and cost required for A/D conversion. This approach can reduce memory overhead, wiring and wiring interconnects, and can provide greater MPU program speed.

Rotary Optical Encoders

Bourns[®] Optical Encoders

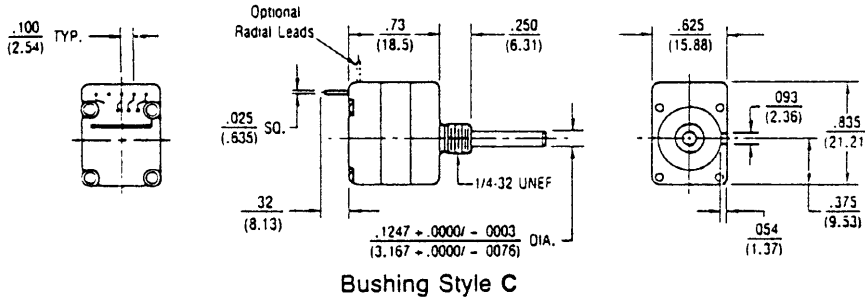

Bushing Style C

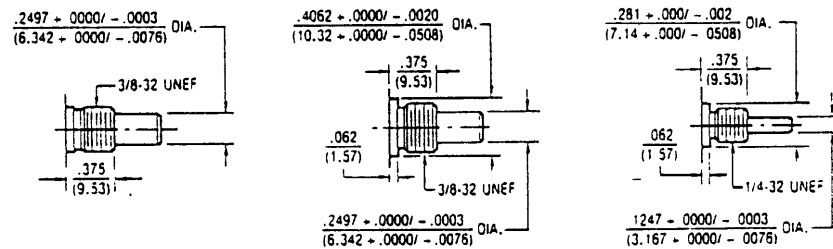

Bushing Style A

Bushing Style S (Ball Bearing)

Bushing Style T (Ball Bearing)

TERMINATION DIAGRAM

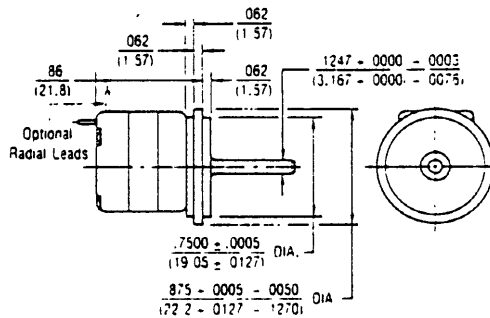
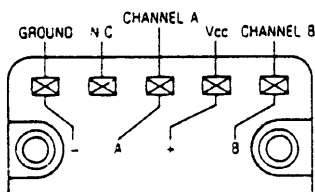

Servo Mount Style W (Ball Bearing)

Consult factory for options not shown, including:

- Wire lead or cable options
- Connectors
- Non-standard resolutions
- Special shaft/bushing sizes and features
- Special performance characteristics
- PCB mounting bracket

Specifications are subject to change without notice.

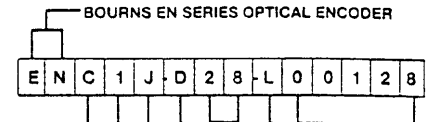

ANTI-ROTATION LUG POSITION

Code	Description
D	None
J	9:00 Position

SHAFT LENGTH*

Code	Description
16	1/2" Long
20	5/8" Long
28	7/8" Long

SWITCHING CONFIGURATION

Code	Description
1	Channel A Leads Channel B By 90 (Clockwise Rotation)**
2	Code 1 Switching With Index Channel

TERMINAL CONFIGURATION

Code	Description
L	Axial, Multi-Purpose Pin
R	Radial, Multi-Purpose Pin

RESOLUTION

Code	Cycles Per Revolution
00025	25
00050	50
00064	64
00100	100
00128	128
00200	200
00256	256***

SHAFT STYLE

Code	Description	Use With Bushings (Code)
B	1/4" Dia., Plain End	A, S
D	1/8" Dia., Plain End	C, T, W

BUSHING CONFIGURATION

Code	Description
A	3/8" D X 3/8" L Threaded
C	1/4" D X 1/4" L Threaded
S	3/8" D X 3/8" L Threaded (Ball Bearing)
T	1/4" D X 3/8" L Threaded (Ball Bearing)
W	Servo Mount 7/8" D (Ball Bearing)

* Shaft length measured from mounting surface.
 ** 25 and 50 ppr is reversed (channel B leads channel A)
 ***S/T/W bushing only

www.DataSheet.in