

GaAs IC 4 Bit Digital Attenuator 1 dB LSB DC–2 GHz



AA210-25
(Previously AD210-25)*

Features

- Attenuation in 1 dB Steps to 15 dB with High Accuracy
- Low Intermodulation Products
- Low Cost SOIC-16 Plastic Package
- Low DC Power Consumption

Description

The AA210-25 is an IC FET digital attenuator consisting of four monolithic attenuators with LSB of 1 dB and a total attenuation of 15 dB with all attenuators connected. Attenuator bits are switched with -5 and 0 V. The AA210-25 is particularly suited where high attenuation accuracy, low insertion loss and low intermodulation products are required. Typical applications include cellular, radio, wireless data, wireless local loop and other gain/level control circuits.

SOIC-16

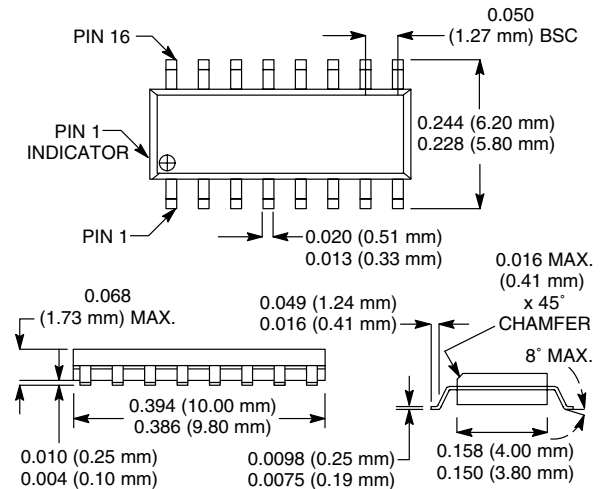

Electrical Specifications at 25°C (0, -5 V)

Parameter ¹	Frequency ²	Min.	Typ.	Max.	Unit
Insertion Loss ³	DC–0.1 GHz		0.9	1.2	dB
	DC–0.5 GHz		1.1	1.5	dB
	DC–1.0 GHz		1.3	1.8	dB
	DC–2.0 GHz		2.1	2.5	dB
Attenuation Range			15		dB
Attenuation Accuracy ⁴	DC–1.0 GHz	± (0.25 + 3% of Attenuation Setting in dB)			dB
	DC–2.0 GHz	± (0.4 + 5% of Attenuation Setting in dB)			dB
VSWR (I/O)	DC–1.0 GHz		1.3:1	1.4:1	
	DC–2.0 GHz		1.6:1	1.8:1	

Operating Characteristics at 25°C (0, -5 V)

Parameter ¹	Condition	Frequency	Min.	Typ.	Max.	Unit
Switching Characteristics ⁵	Rise, Fall (10/90% or 90/10% RF)			15		ns
	On, Off (50% CTL to 90/10% RF)			25		ns
	Video Feedthru			25		mV
Input Power for 1 dB Compression		0.50–2.0 GHz		+28		dBm
		0.05 GHz		+22		dBm
Intermodulation Intercept Point (IP3)	For Two-tone Input Power +5 dBm	0.50–2.0 GHz		+48		dBm
		0.05 GHz		+38		dBm
Control Voltages	$V_{Low} = 0 \text{ to } -0.2 \text{ V @ } 10 \mu\text{A Typ.}$ $V_{High} = -5 \text{ @ } 10 \mu\text{A Typ. to } -8 \text{ V @ } 200 \mu\text{A Typ.}$					

1. All measurements made in a 50 Ω system, unless otherwise specified.

2. DC = 300 kHz.

3. Insertion loss changes by 0.003 dB/°C.

4. Attenuation referenced to insertion loss.

5. Video feedthru measured with 1 ns risetime pulse and 500 MHz bandwidth.

*Due to conflict with another company's product numbering system, Skyworks' attenuator products starting with the letters "AD" are being changed to "AA".

Typical Performance Data (0, -5 V)

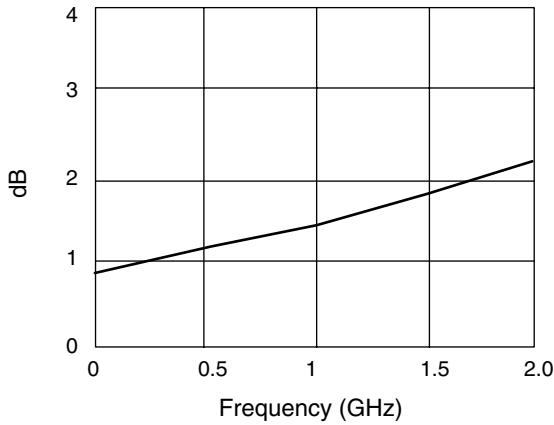

Insertion Loss vs. Frequency

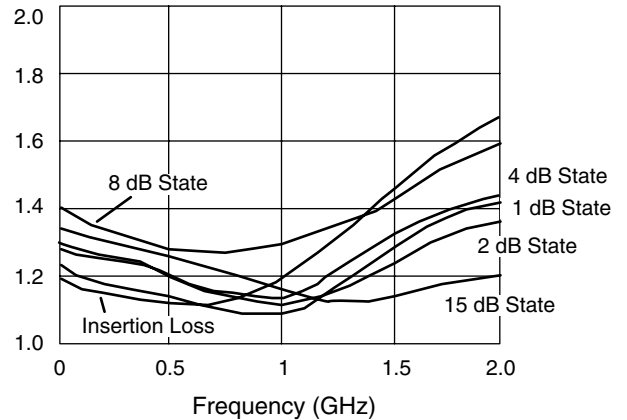

VSWR vs. Frequency

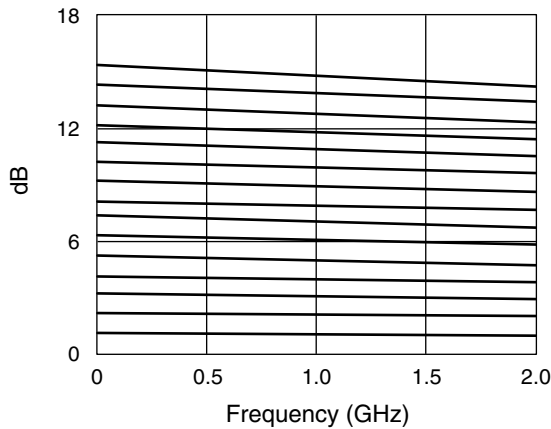

Attenuation vs. Frequency (All States)

Truth Table

V ₁	V ₂	V ₃	V ₄	V ₅	V ₆	V ₇	V ₈	Attenuation J ₁ -J ₂
1 dB	2 dB	4 dB	8 dB					
-5	0	-5	0	-5	0	-5	0	Reference I. L.
0	-5	-5	0	-5	0	-5	0	1 dB
-5	0	0	-5	-5	0	-5	0	2 dB
-5	0	-5	0	0	-5	-5	0	4 dB
-5	0	-5	0	-5	0	0	-5	8 dB
0	-5	0	-5	0	-5	0	-5	15 dB

Absolute Maximum Ratings

Characteristic	Value
RF Input Power	1.5 W > 500 MHz 0/-8 V 0.5 W @ 50 MHz 0/-8 V
Control Voltage	+0.2 V, -8 V
Operating Temperature	-40°C to +85°C
Storage Temperature	-65°C to +150°C

Note: Exceeding these parameters may cause irreversible damage.

Pin Out

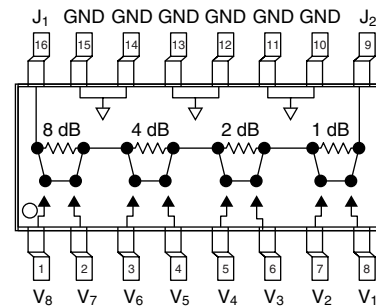

This datasheet has been download from:

www.datasheetcatalog.com

Datasheets for electronics components.