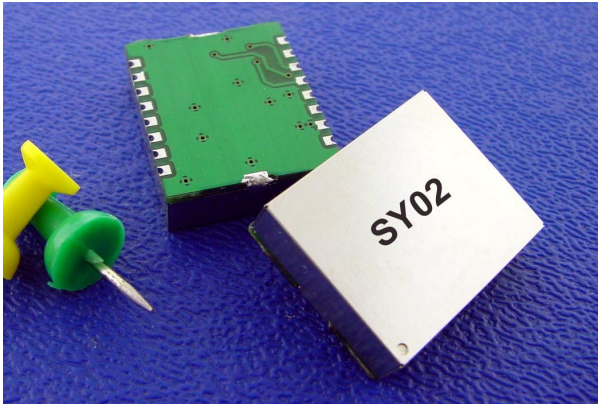

SY02-MFTP

Date: January 8, 2004

**• INTRODUCTION**

The SY02-MFTP is a high frequency crystal-based PLL synchronizer designed as a module level subsystem for easy incorporation into telecommunication equipment SONET/SDH/ATM/DWDM. Supports multiplexing of up to 4 independent references translated into one single jitter free frequency source.

• FEATURES

- Low jitter output from intrinsically low jitter VCXO ;
- User Selected one HCMOS Input frequency **Up to 77.76MHz**
- One high frequency LVPECL output with a complimentary port and enable/disable function **Up to 800MHz** (pre-select frequency value –upon order)
- Alarms status and VCXO monitor;
- The unit changes timing modes in response to external events;
- J-TAG service port for re-programming and servicing;
- 3.3V DC power supply
- Small dimensions: 0.8" x 1.00"

• APPLICATIONS

- ATM
- SDH
- PDH
- SONET
- DWDM
- FEC
- Other telecommunication equipment.

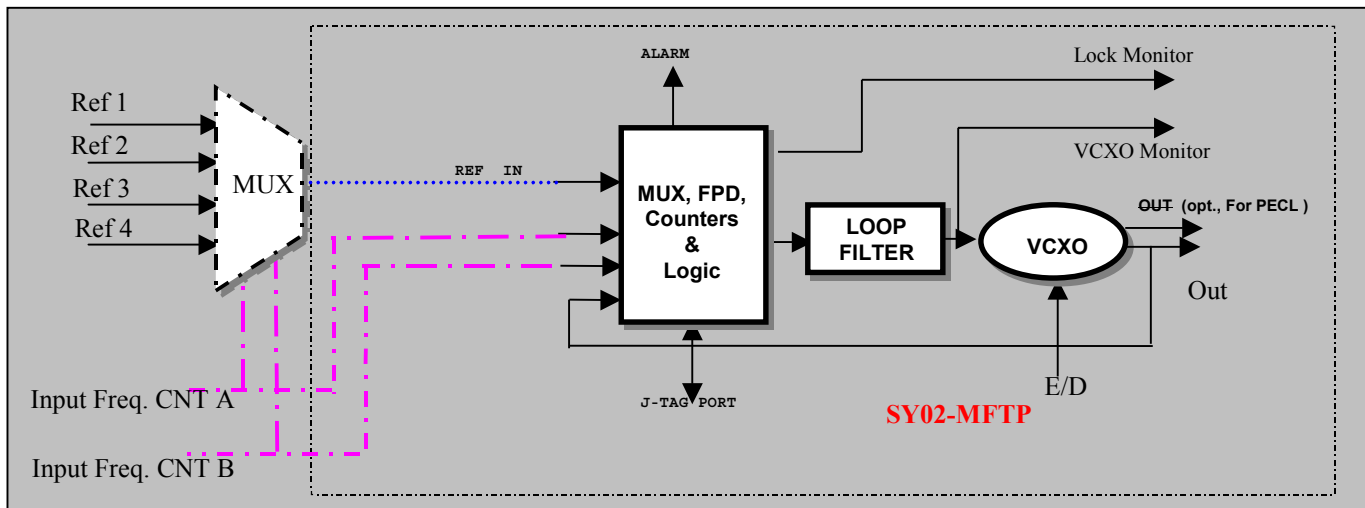

Figure 1 – Block Diagram (***)Components outside the dotted line are user supplied)

DESCRIPTION

The SY02-MFTP is a High Frequency Phase Lock Loop has been designed as a module level subsystem for easy incorporation into telecommunication equipment. The module generates the high frequency (up to 170MHz) output from a low jitter VCXO (Crystal Based Oscillator). The output can be disabled externally by setting OUTEN pin high. The SY02-MFTP can be locked to a user defined input reference signal (**from 8KHz to 77.76MHz...for options please see table**).

Frequency selection could be simultaneously achieved of up to 4 independent sources while combining the module with an external MUX. Raltron's SY02-MFTP device could be used as a frequency translator in PLL circuits or frequency regenerator device in cases where jitter cleaning and filtering is required. The module has a fast locking time and tolerates reference inputs with different duty cycles. The loop bandwidth is optimized in accordance with the VCXO used and

required output performance. The ALARM output signals monitor the status of the phase lock loop and indicates LOL (Loss of Lock Detect). If the reference REF IN is absent, the SY02-MFTP will automatically switch to free run mode and LOL will show "0" logic level. The SMD package dimensions are 0.80"x1.00" inch and powered by a supply of 3.3V.

ALARM STATES

LOLD	ALARM
0	Module in Free-run
1	Module locked

Input Reference Control select

CNT A	CNT B	Selected Option
0	0	EXT Ref 1
0	1	EXT Ref 2
1	0	EXT Ref 3
1	1	EXT Ref 4

● **PIN DESCRIPTION**

	Name	Description	Signal Technology	VL			VH/ DC Voltage		
				Min	Typ	Max	Min	Typ	Max
1	Ref In	Input Reference Signal	HCMOS (3.3 Tolerable)	0	----	0.3	2.97	----	----
2	GND	Ground	----	----	----	----	----	----	----
3	LOL	Lock Detect Alarm out – High when locked; Low when unlocked	DC	0	0.15	0.3	2.97	3.3	3.465
4	MNTR	VCXO Monitor out- DC control voltage offset indicator (when locked shall be within); 0.3<Vmnr<3.0 (for 3.3V supply)	DC	0	0.15	0.3	2.97	3.3	3.465
6	N/C	No Connect	----	----	----	----	----	----	----
7	GND	Ground	----	----	----	----	----	----	----
8	Enable/Disable	Output Enable - > enables the output, active low or floating. Disables the output, active high	DC	0	0.15	0.3	2.97	3.3	3.465
9	OUT	Oscillator Output -> Output of the module	LV/PECL	Vcc-1.680	Vcc-1.620	Vcc-1.560	Vcc-1.085	Vcc-1.025	Vcc-0.885
10	OUT	Oscillator Comp. Output -> Output of the module	LV/PECL	Vcc-1.680	Vcc-1.620	Vcc-1.560	Vcc-1.085	Vcc-1.025	Vcc-0.885
11	N/C	No Connect	----	----	----	----	----	----	----
12	CNT A	Frequency Select; See Table page 2.	DC	0	0.15	0.3	2.97	----	3.465
13	CNT A	Frequency Select; See Table page 2.	DC	0	0.15	0.3	2.97	3.3	3.465
14	N/C	No Connect	----	----	----	----	----	----	----
15	GND	Ground	----	----	----	----	----	----	----
16	Vcc	Positive supply voltage	DC	----	----	----	3.135	3.3	3.465

● **ORDERING INFORMATION**

- Input/Output Frequencies available;

Frequency	Suffix	Frequency	Suffix	Frequency	Suffix
8KHz	F8	38.880MHz	O2	175.0000MHz	C3**
1.024MHz	E0	44.4343MHz	B1	178.9440MHz	C4**
1.544MHz	T1	44.7360MHz	T3	184.3200MHz	C5**
2.048MHz	E1	51.8400MHz	D2	311.0400MHz	O6**
4.096MHz	E2	61.4400MHz	U1	622.0800MHz	O7**
6.1760MHz	T2	62.5000MHz	G5	625.0000MHz	C8**
6.480MHz	D1	65.5360MHz	B2	644.5312MHz	C9**
8.192MHz	E3	77.7600MHz	O3**	666.5143MHz	C10**
10.000MHz	A1	78.125MHz	B3**	669.1281MHz	F1**
12.800MHz	S1	78.6432MHz	B4**	669.3266MHz	F2**
13.000MHz	G1	82.9440MHz	B5**	690.5692MHz	F3**
15.000MHz	A2	92.6000MHz	U3**	710.9486MHz	F4**
16.384MHz	E4	100.000MHz	B6**	719.7344MHz	F5**
19.440MHz	O1	112.000MHz	B7**	777.6000MHz	F6**
20.000MHz	M1	114.000MHz	B8**		
20.1416MHz	A3	125.000MHz	G2**		
20.4800MHz	A4	133.000MHz	G4**		
22.2171MHz	A5	139.264MHz	E6**		
26.0000MHz	G3	155.520MHz	O4**		
27.0000MHz	A6	156.250MHz	G6**		
29.4912MHz	A7	161.1328MHz	B9**		
32.768MHz	E5	166.6286MHz	B10**		
34.560MHz	A8	167.3316MHz	C1**		
37.0560MHz	A9	168.0407MHz	C2**		

** Signifies an Output Frequency Only

➤ P/N System

SY02-MFTP – IP < Input Frequency> - OU<Output Frequency>-S-T<Temp. Range>

➤ See above Chart
(If not listed Place **NL** and state the Freq.)

➤ See above Chart
(If Output Freq. Not applied place **NA** and state the Freq.)

➤ Supply Voltage;
4 – 3.3V

➤ Operating Temperature Range;
C - 0°C to 70°C
I - -40°C to +85°C

● SPECIFICATION

General Specifications	Mechanical	1.000" x 0.800"x0.235"	SMT Module FR4 16 pins dual-in-line
	Power Environment	3.3VDC +/-5%, <200mA Operating Temperature Humidity	Regulated 0°C to 70°C or -40°C to +85°C 5% to 95% non-condensing Depends on the frequency
	Internal Oscillators	VCXO or VCXO	
Input Signals	Number of Reference Inputs	1	Up to 4 selectable with an external MUX
	Input reference frequency Signal Level	Per selected table on page 3 HCMOS (3.3 V tolerable)	(other input frequencies available)
Output Signals	Number of Outputs	1	
	Output 1	Per selected table on page 3	other frequency contact Raltron
	Output 1 Signal Level	LVPECL (W/ Complimentary option)	Voh; 2.272V min ; Vol; 1.68Vmax
	Duty Cycle	50+/-10%	50%+/-5% available upon request
	Tracking/Capture Range	±50ppm APR min	
Signal Quality Performance	Jitter generation	<0.001UI RMS <0.001UI RMS <0.0001 UI RMS <0.0001 UI RMS	HPF 30Hz HPF 500Hz HPF 12KHz HPF 100KHz
	Jitter attenuation	-40dB -10dB	Fj=10Hz~1KHz Fj=1KHz~10MHz
	Jitter tolerance	2 μs, 10 Hz (0.05 UI @ 8KHz)	

- REFLOW PROFILE

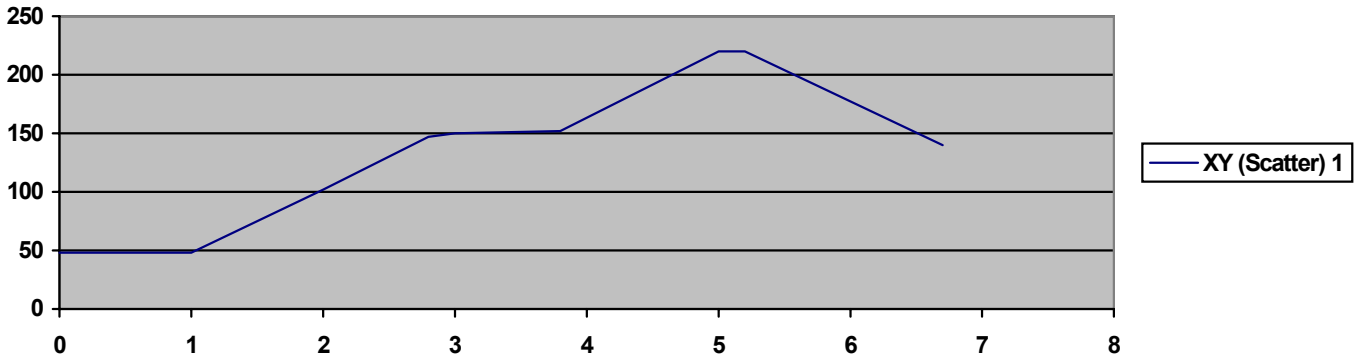

- OUTLINE DRAWING

