

Application Note

AN2611
Rev. 0, 11/2003

*System Considerations for
Short Range RF Devices*



By Laurent GAUTHIER
Access and Remote Control
Toulouse, France

Introduction

This application note presents some considerations concerning Short Range Devices (SRD) at a system level. These allow sizing a system for a given level of performance.

System Overview

A system using an RF link should be designed by keeping in mind the level of performance it should meet. Range is affected by the power of the transmitter, the sensitivity of the receiver, the efficiency of the antennas at both sides and the nature of the field itself.

Before beginning any design, some basic calculations can be done to evaluate if the required performances are possible with the available components. Once every system parameter is validated, it is then possible to begin the design of the electronic parts. If the calculation shows some limits, it is not realistic to imagine that the system will work.

Due to the complex nature of the propagation in a real field, some final field measurements should validate the system. A reasonable margin taken during the design will improve the reliability of the RF link.

System Description

From a system point of view, an SRD application¹ can be seen as:

- the transmitter delivers a power PT_{xout} to the Tx antenna
- the Tx antenna radiates a power PT_{xRad}
- the propagation field attenuates the radiated power
- the Rx antenna receives a power PR_{xRad}
- the receiver receives a power PR_{xin}

The parameters² of the system are:

- System
 - F: frequency of operation expressed in MHz
- Transmitter:
 - P_{txout} : the output power expressed in dBm³
 - G_{TxAnt} : the gain of the antenna expressed in dB⁴
- Propagation field:
 - D: distance between the Tx antenna and the Rx antenna expressed in metres
 - GField: path attenuation, a function of D, F and the field itself
- Receiver:
 - G_{RxAnt} : the gain of the antenna expressed in dB
 - RxSens: the minimum signal power the receiver can process

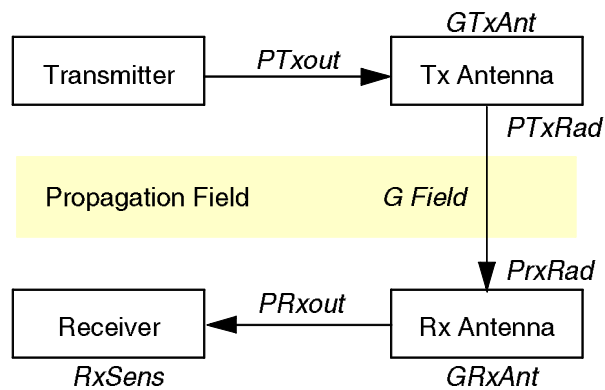

1. SRD applications include remote control and data communications.
 2. All the “gain” and “attenuation” parameters have the same meaning: a positive value means some gain, and a negative value means some attenuation, whatever the parameter is called “Gain”, “Attenuation”, “Margin” or “Loss”.
 3. The dBm is a logarithmic power unit relative to a milliwatt: $PdBm = 10 \cdot \text{Log}(P)$, with P expressed in mW.
 4. A gain expressed in dB (A dB) can be calculated with the scalar gain (A): $A \text{ dB} = 10 \cdot \text{Log}(A)$

Field Attenuation

The field attenuation increases with the distance D and the frequency F. It also depends on the field itself. Some objects around the line of RF transmission can have great influence, because they can reflect the signal, and the receiver will see the sum of the direct wave and many reflected ones. Because the phase of the various signals will vary, if those objects or the transmitter or the receiver will move, this fading can lead to non reliable transmission.

All the computations we will see are based on a “Far Field” approximation¹ and the model is valid for most applications.

With F in MHz and D in metres:

$$G_{Field} = 27.6 - 20 \times \log(F) - n \times \log(D)$$

n is the Path Loss Factor that depends on the field itself, and takes into account different scenarios of multi-path transmission.

| Field | n | Comment |
|--------------|----|---|
| Free space | 20 | applies to open-view line-of-sight propagation |
| Open field | 25 | Tx and Rx 1.5 m above the ground, in a large open space |
| Open office | 30 | indoor open office and retail space |
| Dense office | 40 | dense cubical office space |

Additional Path Loss

To the above attenuation should be added an additional loss that will depend on the object causing the path loss:

| Object | G _{add} | Comments |
|-----------------|------------------|--|
| Wall (indoor) | -10 to -15 dB | |
| Wall (exterior) | 0 to -40 dB | decreases as number of windows increases |
| Floor | -10 to -30 dB | |
| Window | 0 to -30 dB | metal tinted windows cause high loss |

1. The “Far Field” approximation supposes that the receiver is at least at a distance $D > 10 \cdot \lambda$, with $\lambda = c/F$ ($c = 3 \cdot 10^8$ m/s).

Margin and Link Reliability

The range is computed as a limit. That means you need some margins that will depend on the reliability of the RF link you want. In fact, the common way to increase the reliability of a system is to increase the signal level at the receiver side.

| Applications | Link reliability | Margin |
|------------------------|------------------|--------|
| Car locking, Toys | <50% | 0 dB |
| Door chimes | >90% | -10 dB |
| Monitoring systems | >99% | -20 dB |
| Professional telemetry | >99.9% | -30 dB |
| Critical radio link | >99.99% | -40 dB |

Range Computation

The different power levels and parameters of the system, when expressed in dB units (dBm), are linked as follows.

$$PTxRad = PTxout + GTxAnt$$

$$PRxRad = PTxRad + GField + Gadd + Mar$$

$$PRxin = PRxRad + GRxAnt$$

The range of the system is the distance D that implies a received signal power equal to the sensitivity of the receiver, plus the margin defined. So:

$$PRxin = RxSens$$

and

$$RxSens = GRxant + GTxAnt + 27.6 - 20 \times \log(F) - n \times \log(D) + Gadd + Mar + PTxout$$

Then:

$$Range = 10^{\frac{PTxout + GTxAnt + GRxAnt - RxSens + 27.6 - 20 \times \log(F) + Gadd + Mar}{n}}$$

Radiated Power Limits

Regulations of each country limit the power radiated for RF applications. This limits, most of the time, the performance of the system (when the receiver is optimized).

For SRD applications, the limits are given in the following table.¹

| Frequency | PTxRad | RF Field @3m | Country | Regulation |
|------------|-----------|------------------|---------|--------------------------|
| 916.5 MHz | -13.3 dBm | 82 dB μ V/m | USA | FCC 15.231.A-D |
| | -21.3 dBm | 74 dB μ V/m | USA | FCC 15.231.E |
| 868.3 MHz | +14dBm | 109 dB μ V/m | Europe | EN 300 220 |
| 433.92 MHz | +10 dBm | 105 dB μ V/m | Europe | EN 300 220 |
| | -14.4 dBm | 81 dB μ V/m | USA | FCC 15.231.A-D |
| | -22.5 dBm | 73 dB μ V/m | USA | FCC 15.231.E |
| 418 MHz | -6 dBm | 89 dB μ V/m | UK | (out of date regulation) |
| <322 MHz | -41.3 dBm | 54 dB μ V/m | Japan | Bijaku |
| >322 MHz | -64.4 dBm | 31 dB μ V/m | Japan | Bijaku |
| 315 MHz | -19.6 dBm | 76 dB μ V/m | USA | FCC 15.231.A-D |
| | -27.5 dBm | 68 dB μ V/m | USA | FCC 15.231.E |

Some care should be taken when comparing those numbers. For example, in Europe, radiated power is expressed as peak power, and in the USA it is expressed as average power. Some examples of computation for peak and average power are given in the following sections.

System Performance Examples

An Excel sheet is available online² to help system evaluation. It computes the range and the field levels, given all the parameters of the system.

433.92 MHz ETSI Compliant System

ETSI regulations limit the transmitted power to 10 mW or 10 dBm in the 434 MHz band. Some margin should be taken to not exceed this limit over production dispersion, a few dB is enough.

Because it is easier to compare the performance of systems outdoors, we will define a remote control to have the maximum range with a given technology.

- Application:
 - frequency: 433.92MHz
 - European application: $P_{TxRad} = +10$ dBm max
 - not a critical remote control: $M_{ar} = 0$ dB
- The transmitter is a small remote control:
 - an integrated PLL delivering to an amplifier: $P_{Ic_{out}} = 2$ dBm
 - an amplifier delivering to the antenna: $P_{Tx_{out}} = 11$ dBm

1. Motorola provides this general information on the various regulations without guarantee of accuracy or completeness. Please consult each country for the latest information.

2. <http://e-www.motorola.com/webapp/sps/site/taxonomy.jsp?nodeId=01M0ymXyR46>.

- a shortened $\lambda/4$ antenna: $G_{TxAnt} = -5$ dB
- The receiver is defined by:
 - a shortened $\lambda/4$ antenna: $G_{RxAnt} = -5$ dB
 - a receiver composed of:
 - a low noise amplifier
 - a saw filter
 - an integrated receiver
 - overall sensitivity: $RxSens > -105$ dBm
- The propagation Field:
 - the field is open: $n = 25$
 - free line of sight: $G_{add} = 0$ dB

With this definition, the system is compliant with ETSI regulations, because the radiated power is:

$$P_{TxRad} = P_{Txout} + G_{TxAnt} = 11 - 5 = 6 \text{ dBm}$$

We can use the Excel file AN2611XLS to do the range computation.

| | | | |
|--|-----------------|------------------|-----|
| Frequency | <i>F</i> | 433.92 | MHz |
| Tx Output power | <i>Ptxout</i> | 11 | dBm |
| Tx Antenna gain | <i>GTxAnt</i> | -5 | dB |
| Rx Antenna gain | <i>GRxAnt</i> | -5 | dB |
| RX sensitivity | <i>RxSens</i> | -105 | dBm |
| Additional losses | <i>Gadd</i> | 0 | dB |
| Margin | <i>Mar</i> | 0 | dB |
| Path Loss Factor | <i>n</i> | 25 | |
| <input type="button" value="Open field"/> <input type="button" value="Car locking, Toys"/> | | | |
| Radiated power | <i>PTxRad</i> | 6.00dBm | |
| | | 3,981.072μW | |
| Measuring distance | <i>d</i> | 3.00m | |
| Free space field Level | <i>VField</i> | 101.26dBμV/m | |
| | | 115,578.95μV/m | |
| | <i>HField</i> | 49.73dBμA/m | |
| | | 306.58μA/m | |
| Field Level at RX | <i>PrxRad</i> | 29.75dBμV/m | |
| | | 30.72μV/m | |
| Range | <i>D</i> | 1,714.24m | |
| | | 5,624ft | |

The range is then 1714 m.

**315 MHz FCC
Compliant System**

The FCC regulation limits the transmitted power to -19.6 dBm in the 315 MHz band. This power is measured using a CISPR quasi-peak detector that is equivalent to an average filter.

The duty cycle of the transmission depends on the modulation used. For OOK (On/Off Keying), the transmission is cut during low levels, but for FSK (Frequency Shift Keying), the transmission is at constant power.

Then, for an OOK Manchester coding modulated frame, with no pause between successive frames, the duty cycle is 50%; and for an FSK Manchester coding modulated frame, the duty cycle is 100%.

The average factor gives an improvement of: $AF(dB) = -10 \times \log(DC)$

This gives 3 dB in OOK and 0 dB in FSK.

The maximum allowed radiated peak power is -19.6 dBm in FSK and -16.6 dBm in OOK.

Some margin should be allowed to make sure this limit is not exceeded, over production dispersion; a few dB is enough.

Because it is easier to compare the performance of systems outdoors, we will define a remote control to have the maximum range with a given technology.

- Application:
 - Frequency: 315 MHz
 - USA application: $P_{TxRad} = -19.6$ dBm max
 - Not a critical remote control: $M_{ar} = 0$ dB
- The transmitter is a small remote control:
 - An integrated PLL delivering to the antenna: $P_{Txout} = +5$ dBm
 - A small loop antenna: $G_{TxAnt} = -30$ dB
- The receiver is defined by:
 - A shorten $\lambda/4$ antenna: $G_{RxAnt} = -5$ dB
 - A receiver composed of:
 - An integrated receiver: $R_{xSens} < -105$ dBm
- The propagation Field:
 - The field is open: $n = 25$
 - Free line of sight: $G_{add} = 0$ dB

With this definition, the system is compliant with FCC regulation because the radiated power is:

$$P_{TxRad} = P_{Txout} + G_{TxAnt} = 5 - 30 = -25 \text{ dBm}$$

We can use the Excel file RANGE.XLS to do the range computation.

| | | | |
|------------------------|-----------------|----------------|-------------------|
| Frequency | <i>F</i> | 315 | MHz |
| Tx Output power | <i>Ptxout</i> | 5 | dBm |
| Tx Antenna gain | <i>GTxAnt</i> | -30 | dB |
| Rx Antenna gain | <i>GRxAnt</i> | -5 | dB |
| RX sensitivity | <i>RxSens</i> | -105 | dBm |
| Additional losses | <i>Gadd</i> | 0 | dB |
| Margin | <i>Mar</i> | 0 | dB |
| Path Loss Factor | <i>n</i> | 25 | |
| | | Open field | Car locking, Toys |
| Radiated power | <i>PTxRad</i> | -25.00dBm | 3.162μW |
| Measuring distance | <i>d</i> | 3.00m | |
| Free space field Level | <i>VField</i> | 70.26dBμV/m | 3,257.46μV/m |
| | <i>HField</i> | 18.73dBμA/m | 8.64μA/m |
| Field Level at RX | <i>PRxRad</i> | 26.97dBμV/m | 22.30μV/m |
| Range | <i>D</i> | 127.45m | 418ft |

The range is then 127m.

HOW TO REACH US:

USA/EUROPE/LOCATIONS NOT LISTED:

Motorola Literature Distribution
P.O. Box 5405, Denver, Colorado 80217
1-800-521-6274 or 480-768-2130

JAPAN:

Motorola Japan Ltd.
SPS, Technical Information Center
3-20-1, Minami-Azabu
Minato-ku
Tokyo 106-8573, Japan
81-3-3440-3569

ASIA/PACIFIC:

Motorola Semiconductors H.K. Ltd.
Silicon Harbour Centre
2 Dai King Street
Tai Po Industrial Estate
Tai Po, N.T. Hong Kong
852-26668334

HOME PAGE:

<http://motorola.com/semiconductors>

Information in this document is provided solely to enable system and software implementers to use Motorola products. There are no express or implied copyright licenses granted hereunder to design or fabricate any integrated circuits or integrated circuits based on the information in this document.

Motorola reserves the right to make changes without further notice to any products herein. Motorola makes no warranty, representation or guarantee regarding the suitability of its products for any particular purpose, nor does Motorola assume any liability arising out of the application or use of any product or circuit, and specifically disclaims any and all liability, including without limitation consequential or incidental damages. "Typical" parameters which may be provided in Motorola data sheets and/or specifications can and do vary in different applications and actual performance may vary over time. All operating parameters, including "Typicals" must be validated for each customer application by customer's technical experts. Motorola does not convey any license under its patent rights nor the rights of others. Motorola products are not designed, intended, or authorized for use as components in systems intended for surgical implant into the body, or other applications intended to support or sustain life, or for any other application in which the failure of the Motorola product could create a situation where personal injury or death may occur. Should Buyer purchase or use Motorola products for any such unintended or unauthorized application, Buyer shall indemnify and hold Motorola and its officers, employees, subsidiaries, affiliates, and distributors harmless against all claims, costs, damages, and expenses, and reasonable attorney fees arising out of, directly or indirectly, any claim of personal injury or death associated with such unintended or unauthorized use, even if such claim alleges that Motorola was negligent regarding the design or manufacture of the part.



Motorola and the Stylized M Logo are registered in the U.S. Patent and Trademark Office. digital dna is a trademark of Motorola, Inc. All other product or service names are the property of their respective owners. Motorola, Inc. is an Equal Opportunity/Affirmative Action Employer.

© Motorola, Inc. 2003

AN2611

**For More Information On This Product,
Go to: www.freescale.com**