

General Description

The AAT351x PowerManager™ products are members of AnalogicTech™'s Total Power Management IC™ product family. This family of Microprocessor Reset Circuits provides the ultimate in versatility, allowing system designers full customization of the μ P monitor and Reset function without any additional components. The AAT351x family offers several combinations of threshold voltage, watchdog timeout period, reset active period and output drive configurations, which are all factory programmed options. All devices are available in 32 reset threshold voltages from 2.6V up to 5V, with three watchdog timeout periods from 6.3ms to 1600ms and three reset timeouts from 1ms up to 140ms. Available output configurations are active low push-pull, active low open drain, active low bi-directional and active high push-pull

The AAT351x family is designed to ignore fast negative transients on V_{DD} and to ensure that Reset outputs remain valid down to 1V.

The AAT351x family is available in the space saving 5-pin SOT23 surface mount package and is specified over the -40 to +85°C temperature range.

Features

- Tight voltage tolerance: $\pm 1.5\%$
- Low quiescent current: 5 μ A
- Guaranteed Reset Valid down to 1V
- 32 voltage options from 2.6V to 5.0V
- 3 Reset active period options
 - 1ms, 20ms, 140ms
- 3 Watchdog timeout period options
 - 6.3ms, 102ms, 1600ms
- 4 output options:
 - Open drain
 - Inverting
 - Non-inverting
 - Bi-directional
- Low Tempco: 100ppm/°C
- 5-pin SOT23 package

Applications

- Notebook Computers
- Portable Electronics
- Industrial Controllers
- Intelligent Instruments
- Critical μ P and μ C Supply Monitoring
- Power-On reset circuits
- Embedded Control Systems

Typical Application

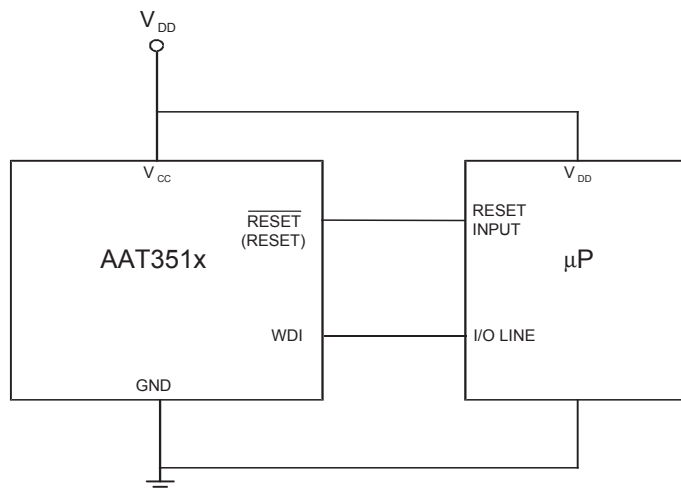

Pin Descriptions

Pin #				Symbol	Function
AAT3510 AAT3511 AAT3517	AAT3512	AAT3513 AAT3514 AAT3518	AAT3515 AAT3516 AAT3519		
1	N/A	1	1	RESET	AAT3510/13/15: RESET output goes low whenever V_{DD} falls below the reset threshold. CMOS push-pull Output AAT3511/14/16: RESET output goes low whenever V_{DD} falls below the reset threshold. Bidirectional CMOS push-pull Output intended to interface directly to microprocessors with bi-directional resets AAT3517/18/19: RESET output goes low whenever V_{DD} falls below the reset threshold. Open drain output. Connect a pull-up resistor to any supply voltage up to 5.5V
2	2	2	2	GND	Ground connection pin
	1	3	3	RESET	RESET active-high output. This CMOS push-pull signal is the logical inverse of RESET.
3	3	N/A	4	MR	Manual reset input pin. Active low. Pull low to force a reset.
4	4	4	N/A	WDI	Watchdog input pin. Triggers a reset if it remains in a steady state for the duration of the watchdog timer period.
5	5	5	5	V_{CC}	Input voltage pin

Pin Configuration

5-lead SOT23
(Top View)



AAT3510
AAT3511
AAT3517

5-lead SOT23
(Top View)



AAT3513
AAT3514
AAT3518

5-lead SOT23
(Top View)



AAT3515
AAT3516
AAT3519

5-lead SOT23
(Top View)



AAT3512

Absolute Maximum Ratings ($T_A=25^\circ\text{C}$ unless otherwise noted)

Symbol	Description	Max	Units
V_{CC}	V_{CC} to GND	-0.3 to 6	V
V_{MR}, V_{WDI}	MR, WDI to GND	-0.3 to $V_{CC}+0.3$	V
V_{RESET}	RESET to GND (Push-Pull or Bidirectional Output)	-0.3 to $V_{CC}+0.3$	V
	RESET to GND (Open Drain Output)	-0.3 to 6	
I_{VCC}, I_{MR}, I_{WDI}	Maximum Continuous Input Current	20	mA
I_{RESET}	RESET/RESET Output Current	20	mA
dV_{CC}/dt	Rate of rise of V_{CC}	100	V/ μ s
T_J	Operating Junction Temperature Range (-40° to 150°C)	150	°C

Note: Stresses above those listed in Absolute Maximum Ratings may cause permanent damage to the device. Functional operation at conditions other than the operating conditions specified is not implied. Only one Absolute Maximum rating should be applied at any one time.

Thermal Information

Symbol	Description	Value	Units
Θ_{JA}	Maximum Thermal Resistance ¹	190	°C/W
P_D	Maximum Power Dissipation ¹	526	mW

Note 1: Mounted on FR4 board

Electrical Characteristics ($V_{CC} = 2.5\text{V}$ to 5.5V , $T_A = -40$ to $+85^\circ\text{C}$ ¹ unless otherwise noted.

Typical values are at $T_A=25^\circ\text{C}$)

Symbol	Description	Conditions	Min	Typ	Max	Units
V_{CC}	Operating Voltage Range	$T_A = -40^\circ\text{C}$ to $+85^\circ\text{C}$	1		5.5	V
I_{CC}	Supply Current	AAT3510/1/2/3/4/7/8: MR & WDI unconnected	$V_{CC} = 3.6\text{V}$	5	15	μA
			$V_{CC} = 5.5\text{V}$	6	18	
		AAT3515/6/9: MR unconnected	$V_{CC} = 3.6\text{V}$		15	
			$V_{CC} = 5.5\text{V}$		18	
V_{TH}	Reset Threshold Voltage	$T_A = 25^\circ\text{C}$	$V_{THNOM}-1.5\%$	V_{TH}	$V_{THNOM}+1.5\%$	V
		$T_A = -40$ to $+85^\circ\text{C}$	$V_{THNOM}-2.5\%$	V_{TH}	$V_{THNOM}+2.5\%$	
T_C	Reference Voltage Temp Coeff	$-40^\circ\text{C} < T_A < +85^\circ\text{C}$		± 40		ppm/°C
t_{RP}	Reset Active Timeout Period	AAT351xIGV-xx-A-x-T1	1	1.4	2	ms
		AAT351xIGV-xx-B-x-T1	20	28	40	
		AAT351xIGV-xx-C-x-T1	140	200	280	
T_{RD}	V_{CC} to RESET Delay	V_{CC} falling at $1\text{mV}/\mu\text{s}$		40		μs

Electrical Characteristics ($V_{CC} = 2.5V$ to $5.5V$, $T_A = -40$ to $+85^\circ C$ ¹ unless otherwise noted.)

Typical values are at $T_A = 25^\circ C$)

Symbol	Description	Conditions	Min	Typ	Max	Units
Push/Pull RESET Output (AAT3510, 3512, 3513, 3514, 3515, 3516, 3518, 3519)						
V_{OL}	\overline{RESET} Low Output Voltage	$V_{CC} \geq 1.0V$, $I_{SINK} = 50\mu A$			0.3	V
		$V_{CC} \geq 1.2V$, $I_{SINK} = 100\mu A$			0.3	
		$V_{CC} \geq 2.7V$, $I_{SINK} = 1.2mA$			0.3	
		$V_{CC} \geq 4.5V$, $I_{SINK} = 3.2mA$			0.4	
V_{OH}	\overline{RESET} High Output Voltage	$V_{CC} \geq 2.7V$, $I_{SOURCE} = 500\mu A$	$0.8 \times V_{CC}$			V
		$V_{CC} \geq 4.5V$, $I_{SOURCE} = 800\mu A$	$V_{CC} - 1.5$			
V_{OH}	RESET Low Output Voltage	$V_{CC} \geq 2.7V$, $I_{SINK} = 1.2mA$			0.3	V
		$V_{CC} \geq 4.5V$, $I_{SINK} = 3.2mA$			0.4	
	RESET High Output Voltage	$V_{CC} \geq 1.8V$, $I_{SOURCE} = 150\mu A$	$0.8 \times V_{CC}$			
		$V_{CC} \geq 2.7V$, $I_{SOURCE} = 500\mu A$	$0.8 \times V_{CC}$			
		$V_{CC} \geq 4.5V$, $I_{SOURCE} = 800\mu A$	$V_{CC} - 1.5$			
Bidirectional RESET Output (AAT3511, 3514, 3516)						
t_s	Transition Flip-Flop Setup Time ²			400		ns
t_R	\overline{RESET} Output Rise Time ³	$V_{CC} = 3.0V$, $C_L = 120pF$			333	ns
		$V_{CC} = 5.0V$, $C_L = 200pF$			333	
		$V_{CC} = 3.0V$, $C_L = 250pF$			666	
		$V_{CC} = 5.0V$, $C_L = 400pF$			666	
V_{PTH}	Active Pullup Enable Threshold	$V_{CC} = 5.0V$	0.4	0.65		V
	\overline{RESET} Active Pullup Current	$V_{CC} = 5.0V$		20		mA
	\overline{RESET} Pullup Resistance		4.2	4.7	5.2	k Ω
Open-Drain RESET Output (AAT3517, 3518, 3519)						
V_{OL}	\overline{RESET} Low Output Voltage	$V_{CC} \geq 1.0V$, $I_{SINK} = 50\mu A$			0.3	V
		$V_{CC} \geq 1.2V$, $I_{SINK} = 100\mu A$			0.3	
		$V_{CC} \geq 2.7V$, $I_{SINK} = 1.2mA$			0.3	
		$V_{CC} \geq 4.5V$, $I_{SINK} = 3.2mA$			0.4	
$I_{D(OFF)}$	Reset Leakage Current				1.0	μA
Watchdog Input (AAT3510, 3511, 3512, 3513, 3514, 3517, 3518)						
t_{WD}	Watchdog Timeout Period	AAT351xIGV-xx-x-A-T1	4.3	6.3	9.3	ms
		AAT351xIGV-xx-x-B-T1	71	102	153	
		AAT351xIGV-xx-x-C-T1 ⁴	1.12	1.6	2.4	s
t_{WDI}	WDI Minimum Pulse Width	$V_{IL} = 0.3 \times V_{CC}$, $V_{IH} = 0.7 \times V_{CC}$		50		ns
V_{IL}	WDI Input Threshold ⁵		$0.3 \times V_{CC}$			
V_{IH}	WDI Input Threshold ⁵				$0.8 \times V_{CC}$	V
I_{WDI}	WDI Input Current ⁶	WDI = V_{CC} , time average		120	160	μA
		$V_{WDI} = 0$, time average	-20	-15		

Symbol	Description	Conditions	Min	Typ	Max	Units
Manual RESET Input (AAT3510, 3511, 3512, 3515, 3516, 3517, 3519)						
V_{IL}	\overline{MR} Input Threshold		$0.3 \times V_{CC}$			V
V_{IH}	\overline{MR} Input Threshold				$0.7 \times V_{CC}$	
	\overline{MR} Input Pulse Width		1			μ s
	\overline{MR} Glitch Rejection			100		ns
	\overline{MR} Internal Pullup Resistance	$T_A = 25^\circ\text{C}$	35	52	75	k Ω
	\overline{MR} to Reset Delay	$V_{CC} = 5\text{V}$		230		ns

Note 1: Over-temperature limits are guaranteed by design, not production tested.

Note 2: This is the minimum time \overline{RESET} must be held low by an external pulldown source to set the active pullup flip-flop.

Note 3: Measured from $\overline{RESET} V_{OL}$ to $(0.8 \times V_{CC})$, Open Circuit Output.

Note 4: Watchdog timeout period C is not available on AAT3513, AAT3514, and AAT3518.

Note 5: WDI is internally serviced within the watchdog period if WDI is left unconnected.

Note 6: The WDI input current is specified as the average input current when the WDI input is driven high or low. The WDI input is designed for a three-stated-output device with a $10\mu\text{A}$ maximum leakage current and capable of driving a maximum capacitive load of 200pF . The three-state device must be able to source and sink at least $200\mu\text{A}$ when active.

Typical Characteristics

(Unless otherwise noted, $V_{IN} = 3V$, $T_A = 25^\circ C$)

Supply Current vs. Temperature

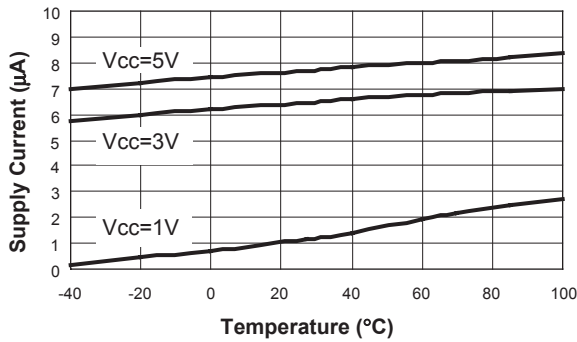

Vcc Falling To RESET Propagation Delay vs. Temperature

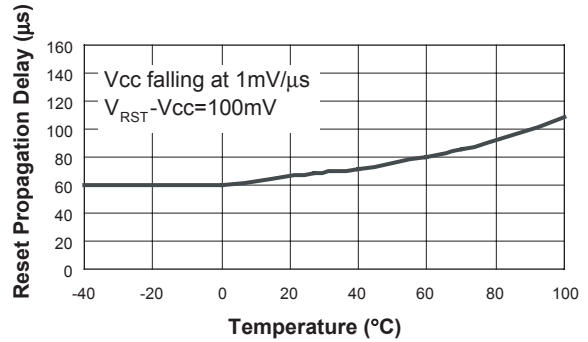

Manual Reset to RESET Propagation Delay vs. Temperature

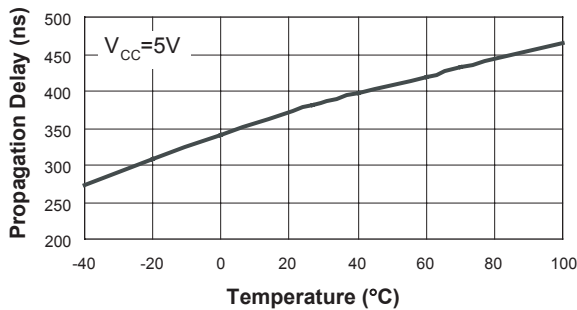

Normalized Reset Timeout Period vs. Temperature

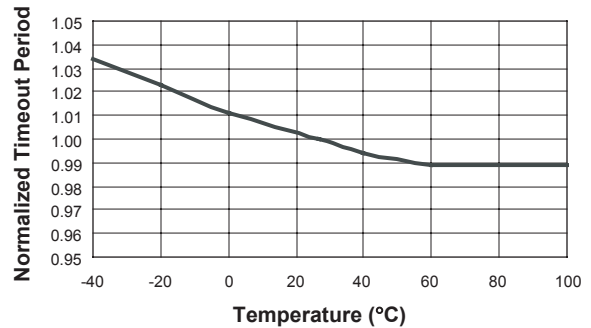

Normalized Watchdog Timeout Period vs. Temperature

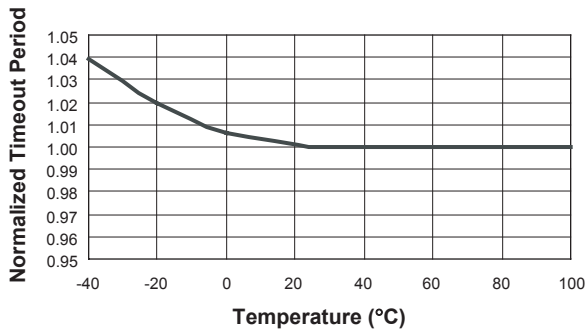

Maximum Vcc Transient Duration vs. Reset Threshold Overdrive

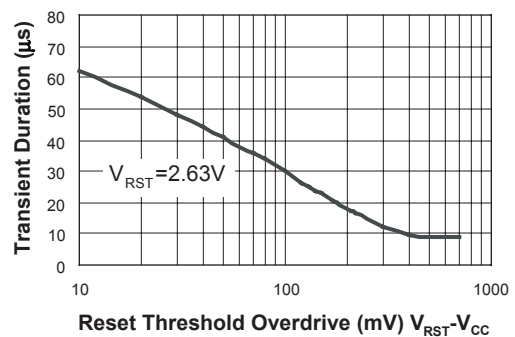

Typical Characteristics

(Unless otherwise noted, $V_{IN} = 3V$, $T_A = 25^\circ C$)

Bidirectional Pullup Characteristic

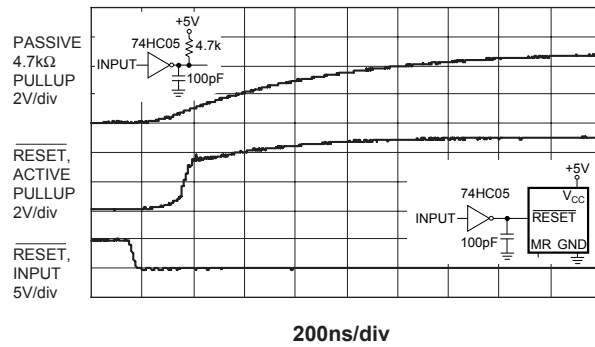

Functional Block Diagram

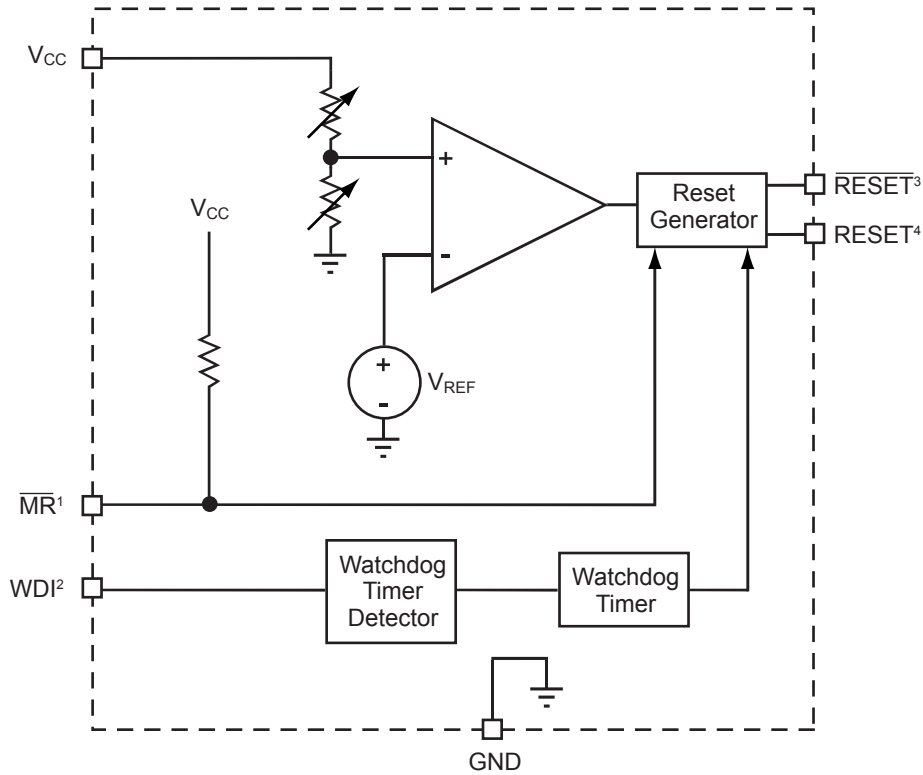

Note 1: MR pin available on AAT3510/1/2/5/6/7/9

Note 2: WDI pin available on AAT3510/1/2/3/4/7/8

Note 3: $\overline{\text{RESETP}}$ pin available on AAT3510/1/3/4/5/6/7/8/9

Note 4: RESET pin available on AAT3512/3/4/5/6/8/9

Factory Trimmed Reset Thresholds* and Ordering Information

AAT351x IGV - X.XX - X-X - X-T1

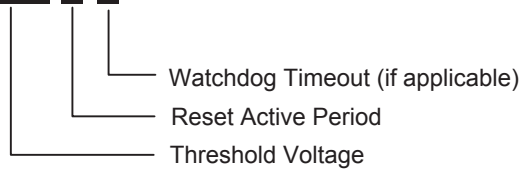

Reset Active Period

- A: $T_{R(MIN)} = 1\text{ms}$
- B: $T_{R(MIN)} = 20\text{ms}$
- C: $T_{R(MIN)} = 140\text{ms}$

Watchdog Timeout Period

- A: $T_{WD(NOM)} = 6.3\text{ms}$
- B: $T_{WD(NOM)} = 102\text{ms}$
- C: $T_{WD(NOM)} = 1600\text{ms}^*$

VDD Threshold Voltage

2.63: $V_{TH(NOM)} = 2.63\text{V}$	3.90: $V_{TH(NOM)} = 3.9\text{V}$
2.70: $V_{TH(NOM)} = 2.7\text{V}$	4.00: $V_{TH(NOM)} = 4.0\text{V}$
2.80: $V_{TH(NOM)} = 2.8\text{V}$	4.10: $V_{TH(NOM)} = 4.1\text{V}$
2.93: $V_{TH(NOM)} = 2.93\text{V}$	4.20: $V_{TH(NOM)} = 4.2\text{V}$
3.00: $V_{TH(NOM)} = 3.0\text{V}$	4.38: $V_{TH(NOM)} = 4.3\text{V}$
3.08: $V_{TH(NOM)} = 3.08\text{V}$	4.40: $V_{TH(NOM)} = 4.38\text{V}$
3.20: $V_{TH(NOM)} = 3.2\text{V}$	4.50: $V_{TH(NOM)} = 4.5\text{V}$
3.30: $V_{TH(NOM)} = 3.3\text{V}$	4.63: $V_{TH(NOM)} = 4.63\text{V}$
3.40: $V_{TH(NOM)} = 3.4\text{V}$	4.70: $V_{TH(NOM)} = 4.7\text{V}$
3.50: $V_{TH(NOM)} = 3.5\text{V}$	4.80: $V_{TH(NOM)} = 4.8\text{V}$
3.60: $V_{TH(NOM)} = 3.6\text{V}$	4.90: $V_{TH(NOM)} = 4.9\text{V}$
3.70: $V_{TH(NOM)} = 3.7\text{V}$	5.00: $V_{TH(NOM)} = 5.0\text{V}$
3.80: $V_{TH(NOM)} = 3.8\text{V}$	

* Watchdog timeout period C is not available on AAT3513, AAT3514 and AAT3518.

Ordering Information

Package	Marking ¹	Part Number (Tape and Reel)
SOT23-5	HVXYY	AAT3510IGV-2.63-C-C-T1
SOT23-5	HUXYY	AAT3510IGV-2.93-C-C-T1
SOT23-5	HGXYY	AAT3510IGV-3.08-C-C-T1
SOT23-5	GLXYY	AAT3510IGV-4.00-B-D-T1
SOT23-5	HHXYY	AAT3510IGV-4.38-C-C-T1
SOT23-5	EWXYY	AAT3511IGV-2.63-C-C-T1
SOT23-5	JOXYY	AAT3512IGV-2.63-C-C-T1
SOT23-5	HFXYY	AAT3513IGV-2.63-C-C-T1
SOT23-5	HEXYY	AAT3515IGV-2.63-C-T1
SOT23-5	EXXYY	AAT3515IGV-2.63-B-C-T1
SOT23-5	HIXYY	AAT3515IGV-2.93-B-T1
SOT23-5	KLXYY	AAT3515IGV-2.93-C-T1
SOT23-5	JNXYY	AAT3515IGV-3.08-C-T1
SOT23-5	KMXYY	AAT3515IGV-4.38-C-T1
SOT23-5	INXYY	AAT3517IGV-2.63-C-C-T1
SOT23-5	IQXYY	AAT3517IGV-2.93-C-C-T1
SOT23-5	IOXYY	AAT3517IGV-3.20-C-D-T1

Note 1: XYY = date and assembly code.

Package Information

SOT23-5

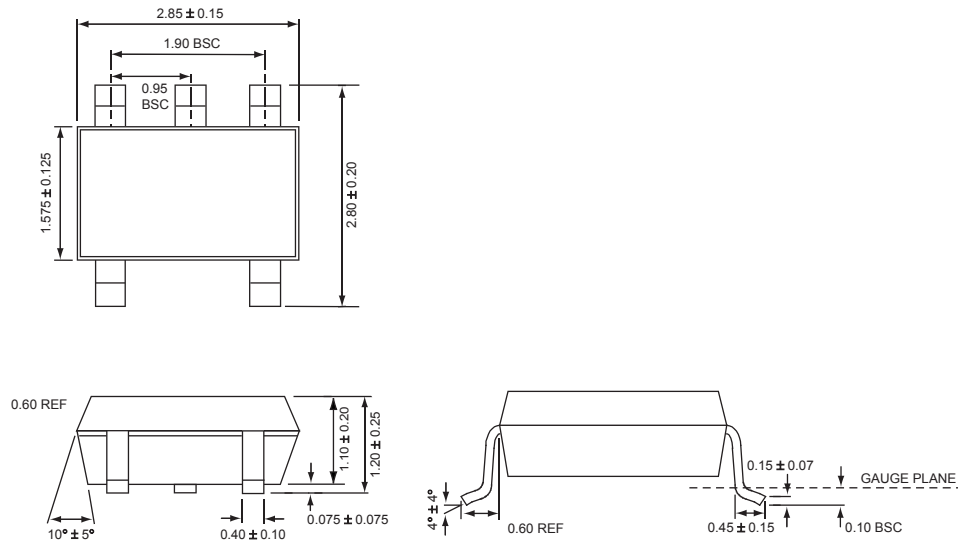

All dimensions in millimeters.

AnalogicTech cannot assume responsibility for use of any circuitry other than circuitry entirely embodied in an AnalogicTech product. No circuit patent licenses, copyrights, mask work rights, or other intellectual property rights are implied.

AnalogicTech reserves the right to make changes to their products or specifications or to discontinue any product or service without notice, and advise customers to obtain the latest version of relevant information to verify, before placing orders, that information being relied on is current and complete. All products are sold subject to the terms and conditions of sale supplied at the time of order acknowledgement, including those pertaining to warranty, patent infringement, and limitation of liability.

AnalogicTech warrants performance of its semiconductor products to the specifications applicable at the time of sale in accordance with AnalogicTech's standard warranty. Testing and other quality control techniques are utilized to the extent AnalogicTech deems necessary to support this warranty. Specific testing of all parameters of each device is not necessarily performed.

Advanced Analogic Technologies, Inc.
830 E. Arques Avenue, Sunnyvale, CA 94085
Phone (408) 737-4600
Fax (408) 737-4611

This datasheet has been download from:

www.datasheetcatalog.com

Datasheets for electronics components.