

Document Title

128Kx8 bit Low Power CMOS Static RAM

Revision History

<u>Revision No.</u>	<u>History</u>	<u>Draft Data</u>	<u>Remark</u>
0.0	Design target	October 12, 1998	Preliminary
1.0	Finalize - Improve twp form 55ns to 50ns for 70ns product. - Remove 55ns speed bin for industrial product.	August 30, 1999	Final
1.01	Errata correction	December 1, 1999	

The attached datasheets are provided by SAMSUNG Electronics. SAMSUNG Electronics CO., LTD. reserves the right to change the specifications and products. SAMSUNG Electronics will answer to your questions. If you have any questions, please contact the SAMSUNG branch offices.

128Kx8 bit Low Power CMOS Static RAM

FEATURES

- Process Technology: TFT
- Organization: 128Kx8
- Power Supply Voltage: 4.5~5.5V
- Low Data Retention Voltage: 2V(Min)
- Three state output and TTL Compatible
- Package Type: 32-DIP-600, 32-SOP-525, 32-TSOP1-0820F

GENERAL DESCRIPTION

The KM681000E families are fabricated by SAMSUNG's advanced CMOS process technology. The families support various operating temperature ranges and have various package types for user flexibility of system design. The families also support low data retention voltage for battery back-up operation with low data retention current.

PRODUCT FAMILY

Product Family	Operating Temperature	Vcc Range	Speed	Power Dissipation		PKG Type
				Standby (I _{SB1} , Max)	Operating (I _{CC2} , Max)	
KM681000EL	Commercial(0~70°C)	4.5~5.5V	55 ¹⁾ /70ns	50μA	50mA	32-DIP, 32-SOP 32-TSOP1-0820F
KM681000EL-L				10μA		
KM681000ELI	Industrial(-40~85°C)		70ns	50μA		32-SOP -525 32-TSOP1-0820F
KM681000ELI-L				15μA		

1. The parameters are tested with 50pF test load

PIN DESCRIPTION

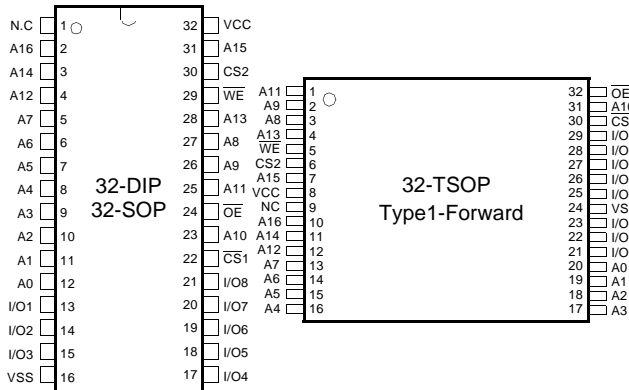

Name	Function
$\overline{CS}_1, \overline{CS}_2$	Chip Select Input
\overline{OE}	Output Enable Input
\overline{WE}	Write Enable Input
I/O1~I/O8	Data Inputs/Outputs
A0~A16	Address Inputs
Vcc	Power
Vss	Ground
N.C.	No Connection

FUNCTIONAL BLOCK DIAGRAM

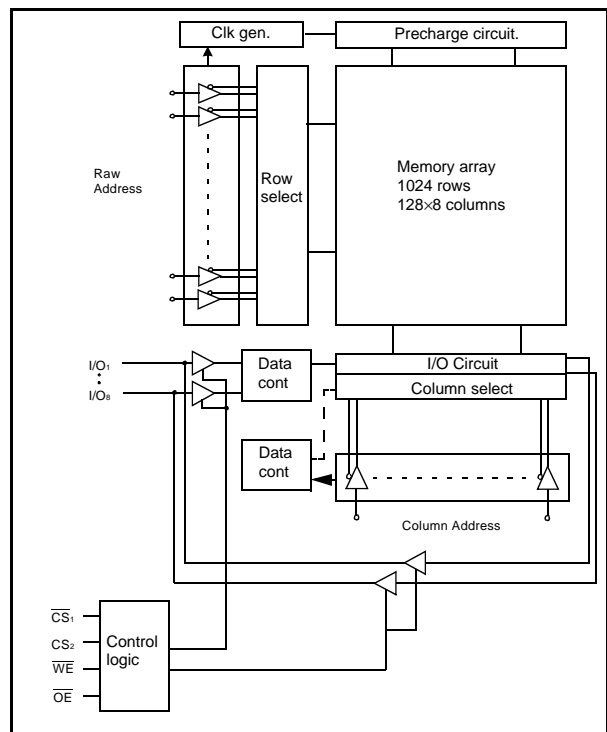

SAMSUNG ELECTRONICS CO., LTD. reserves the right to change products and specifications without notice.

PRODUCT LIST

Commercial Temperature Products(0~70°C)		Industrial Temperature Products(-40~85°C)	
Part Name	Function	Part Name	Function
KM681000ELP-5	32-DIP, 55ns, Low Power	KM681000ELGI-7	32-SOP, 70ns, Low Power
KM681000ELP-7	32-DIP, 70ns, Low Power	KM681000ELGI-7L	32-SOP, 70ns, Low Low Power
KM681000ELP-5L	32-DIP, 55ns, Low Low Power	KM681000ELTI-7L	32-TSOP F, 70ns, Low Low Power
KM681000ELP-7L	32-DIP, 70ns, Low Low Power		
KM681000ELG-5	32-SOP, 55ns, Low Power		
KM681000ELG-7	32-SOP, 70ns, Low Power		
KM681000ELG-5L	32-SOP, 55ns, Low Low Power		
KM681000ELG-7L	32-SOP, 70ns, Low Low Power		
KM681000ELT-5L	32-TSOP F, 55ns, Low Low Power		
KM681000ELT-7L	32-TSOP F, 70ns, Low Low Power		

FUNCTIONAL DESCRIPTION

\overline{CS}_1	CS_2	\overline{OE}	\overline{WE}	I/O	Mode	Power
H	X ¹⁾	X ¹⁾	X ¹⁾	High-Z	Deselected	Standby
X ¹⁾	L	X ¹⁾	X ¹⁾	High-Z	Deselected	Standby
L	H	H	H	High-Z	Output Disabled	Active
L	H	L	H	Dout	Read	Active
L	H	X ¹⁾	L	Din	Write	Active

1. X means don't care (Must be in high or low states)

ABSOLUTE MAXIMUM RATINGS¹⁾

Item	Symbol	Ratings	Unit	Remark
Voltage on any pin relative to Vss	V _{IN} , V _{OUT}	-0.5 to 7.0	V	-
Voltage on Vcc supply relative to Vss	V _{CC}	-0.5 to 7.0	V	-
Power Dissipation	P _D	1.0	W	-
Storage temperature	T _{STG}	-65 to 150	°C	-
Operating Temperature	T _A	0 to 70	°C	KM681000EL
		-40 to 85	°C	KM681000ELI

1. Stresses greater than those listed under "Absolute Maximum Ratings" may cause permanent damage to the device. Functional operation should be restricted to recommended operating condition. Exposure to absolute maximum rating conditions for extended periods may affect reliability.

RECOMMENDED DC OPERATING CONDITIONS¹⁾

Item	Symbol	Product	Min	Typ	Max	Unit
Supply voltage	V _{CC}	KM681000E Family	4.5	5.0	5.5	V
Ground	V _{SS}	All Family	0	0	0	V
Input high voltage	V _{IH}	KM681000E Family	2.2	-	V _{CC} +0.5 ²⁾	V
Input low voltage	V _{IL}	KM681000E Family	-0.5 ³⁾	-	0.8	V

Note:

1. Commercial Product: T_A=0 to 70°C, and Industrial Product: T_A=-40 to 85°C, otherwise specified
2. Overshoot : V_{CC}+3.0V in case of pulse width≤30ns
3. Undershoot : -3.0V in case of pulse width≤30ns
4. Overshoot and undershoot are sampled, not 100% tested.

CAPACITANCE¹⁾ (f=1MHz, T_A=25°C)

Item	Symbol	Test Condition	Min	Max	Unit
Input capacitance	C _{IN}	V _{IN} =0V	-	6	pF
Input/Output capacitance	C _{IO}	V _{IO} =0V	-	8	pF

1. Capacitance is sampled, not 100% tested

DC AND OPERATING CHARACTERISTICS

Item	Symbol	Test Conditions	Min	Typ	Max	Unit
Input leakage current	I _{LI}	V _{IN} =V _{SS} to V _{CC}	-1	-	1	μA
Output leakage current	I _{LO}	$\overline{CS}_1=V_{IH}$ or $\overline{CS}_2=V_{IL}$ or $\overline{OE}=V_{IH}$ or $\overline{WE}=V_{IL}$, V _{IO} =V _{SS} to V _{CC}	-1	-	1	μA
Operating power supply current	I _{CC}	I _{IO} =0mA, $\overline{CS}_1=V_{IL}$, $\overline{CS}_2=V_{IH}$, V _{IN} =V _{IH} or V _{IL} , Read	-	-	10	mA
Average operating current	I _{CC1}	Cycle time=1μs, 100%duty, I _{IO} =0mA, $\overline{CS}_1\leq 0.2V$, $\overline{CS}_2\geq V_{CC}-0.2V$, V _{IN} ≤0.2V	-	-	7	mA
	I _{CC2}	Cycle time=Min, 100% duty, I _{IO} =0mA, $\overline{CS}_1=V_{IL}$, $\overline{CS}_2=V_{IH}$, V _{IN} =V _{IH} or V _{IL}	-	-	50	mA
Output low voltage	V _{OL}	I _{OL} =2.1mA	-	-	0.4	V
Output high voltage	V _{OH}	I _{OH} =-1.0mA	2.4	-	-	V
Standby Current(TTL)	I _{SB}	$\overline{CS}_1=V_{IH}$, $\overline{CS}_2=V_{IL}$, Other inputs=V _{IH} or V _{IL}	-	-	3	mA
Standby Current(CMOS)	I _{SB1}	$\overline{CS}_1\geq V_{CC}-0.2V$, $\overline{CS}_2\geq V_{CC}-0.2V$ or $\overline{CS}_2\leq 0.2V$, Other inputs=0~V _{CC}	-	-	50 ¹⁾	μA

1. 50μA for Low power product, in case of Low Low power products are comercial=10μA, industrial=15μA.

AC OPERATING CONDITIONS

TEST CONDITIONS (Test Load and Input/Output Reference)

Input pulse level : 0.8 to 2.4V
 Input rising and falling time : 5ns
 Input and output reference voltage : 1.5V
 Output load(see right) : $C_L=100\text{pF}+1\text{TTL}$
 $C_L=50\text{pF}+1\text{TTL}$

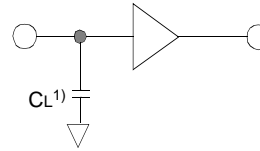

1. Including scope and jig capacitance

AC CHARACTERISTICS ($V_{CC}=4.5\sim 5.5\text{V}$, Commercial Product : $T_A=0$ to 70°C , Industrial Product : $T_A=-40$ to 85°C)

Parameter List		Symbol	Speed Bins				Units
			55ns		70ns		
			Min	Max	Min	Max	
Read	Read cycle time	t _{RC}	55	-	70	-	ns
	Address access time	t _{AA}	-	55	-	70	ns
	Chip select to output	t _{CO1} , t _{CO2}	-	55	-	70	ns
	Output enable to valid output	t _{OE}	-	25	-	35	ns
	Chip select to low-Z output	t _{LZ}	10	-	10	-	ns
	Output enable to low-Z output	t _{OLZ}	5	-	5	-	ns
	Chip disable to high-Z output	t _{HZ}	0	20	0	25	ns
	Output disable to high-Z output	t _{OHZ}	0	20	0	25	ns
	Output hold from address change	t _{OH}	10	-	10	-	ns
Write	Write cycle time	t _{WC}	55	-	70	-	ns
	Chip select to end of write	t _{CW}	45	-	60	-	ns
	Address set-up time	t _{AS}	0	-	0	-	ns
	Address valid to end of write	t _{AW}	45	-	60	-	ns
	Write pulse width	t _{WP}	40	-	50	-	ns
	Write recovery time	t _{WR}	0	-	0	-	ns
	Write to output high-Z	t _{WHZ}	0	20	0	25	ns
	Data to write time overlap	t _{DW}	20	-	25	-	ns
	Data hold from write time	t _{DH}	0	-	0	-	ns
	End write to output low-Z	t _{OW}	5	-	5	-	ns

DATA RETENTION CHARACTERISTICS

Item	Symbol	Test Condition	Min	Typ	Max	Unit	
V _{CC} for data retention	V _{DR}	$\overline{CS}_1 \geq V_{CC}-0.2\text{V}^1)$	2.0	-	5.5	V	
Data retention current	I _{DR}	$V_{CC}=3.0\text{V}$, $\overline{CS}_1 \geq V_{CC}-0.2\text{V}^1)$	KM681000EL	-	-	20	μA
			KM681000EL-L	-	-	10	
			KM681000ELI	-	-	25	
			KM681000ELI-L	-	-	10	
Data retention set-up time	t _{SDR}	See data retention waveform	0	-	-	ms	
Recovery time	t _{RDR}		5	-	-		

1. $\overline{CS}_1 \geq V_{CC}-0.2\text{V}$, $\overline{CS}_2 \geq V_{CC}-0.2\text{V}$ (\overline{CS}_1 controlled) or $\overline{CS}_2 \leq 0.2\text{V}$ (\overline{CS}_2 controlled)

TIMMING DIAGRAMS

TIMING WAVEFORM OF READ CYCLE(1) (Address Controlled, $\overline{CS1}=\overline{OE}=V_{IL}$, $CS2=\overline{WE}=V_{IH}$)

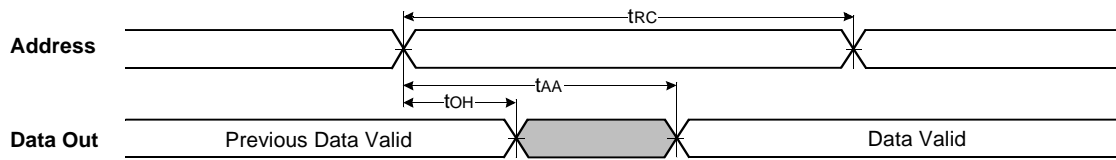

TIMING WAVEFORM OF READ CYCLE(2) ($\overline{WE}=V_{IH}$)

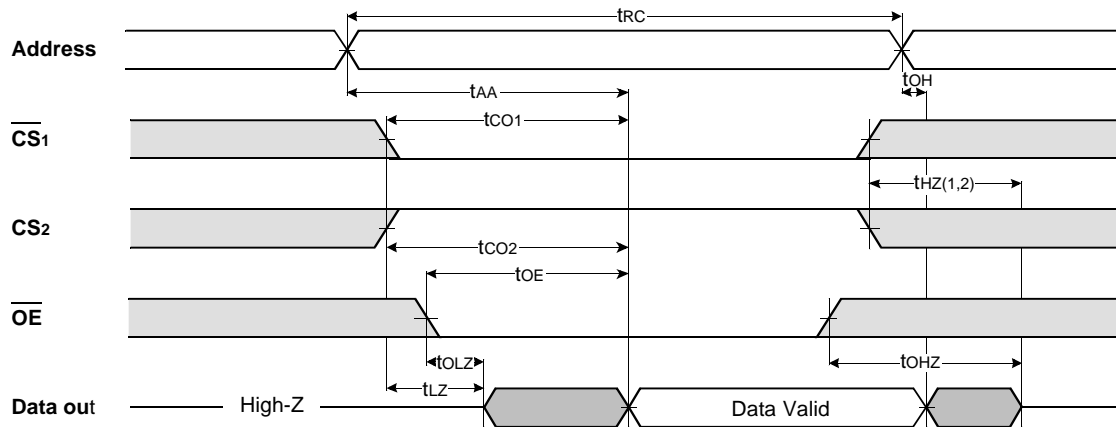

NOTES (READ CYCLE)

1. t_{HZ} and t_{OHZ} are defined as the time at which the outputs achieve the open circuit conditions and are not referenced to output voltage levels.
2. At any given temperature and voltage condition, $t_{HZ}(\text{Max.})$ is less than $t_{LZ}(\text{Min.})$ both for a given device and from device to device interconnection.

TIMING WAVEFORM OF WRITE CYCLE(1) (\overline{WE} Controlled)

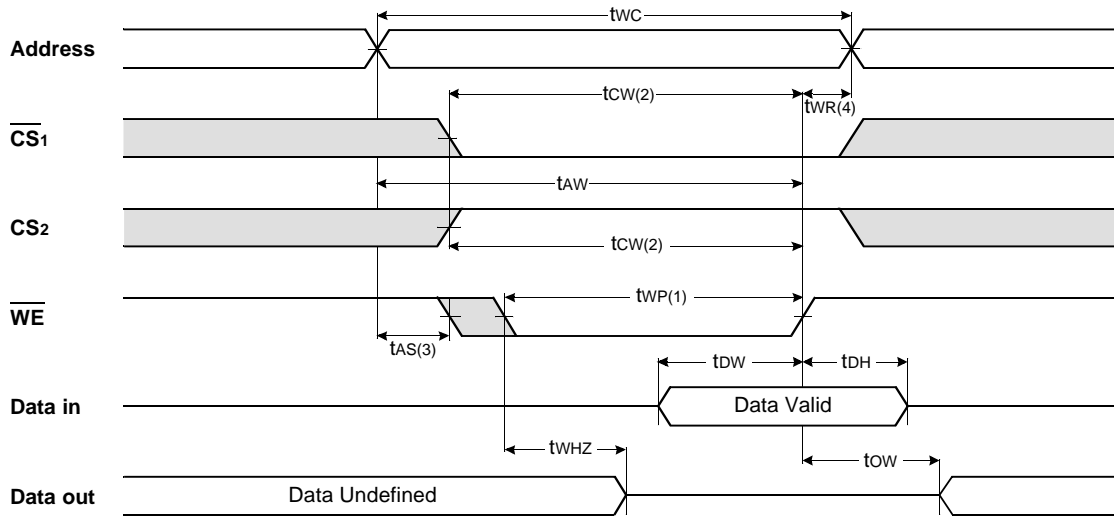

TIMING WAVEFORM OF WRITE CYCLE(2) ($\overline{CS1}$ Controlled)

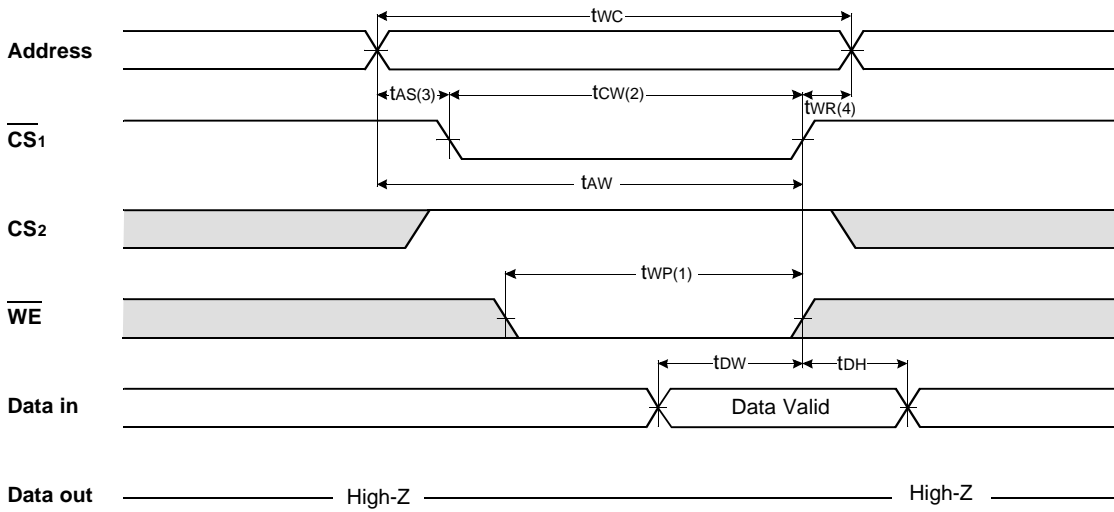

TIMING WAVEFORM OF WRITE CYCLE(3) (CS₂ Controlled)

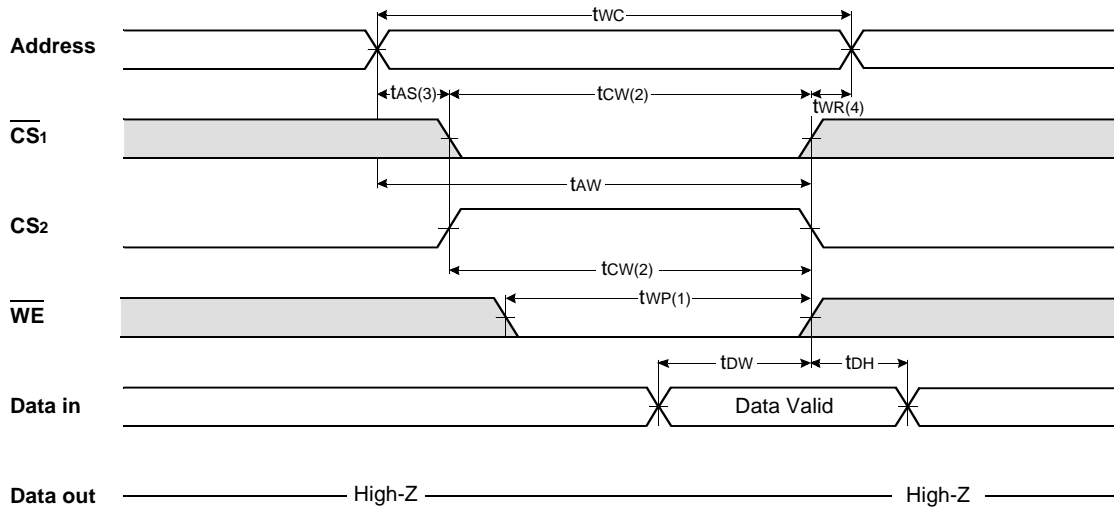

NOTES (WRITE CYCLE)

1. A write occurs during the overlap of a low \overline{CS}_1 , a high CS_2 and a low \overline{WE} . A write begins at the latest transition among \overline{CS}_1 goes low, CS_2 going high and \overline{WE} going low : A write ends at the earliest transition among CS_1 going high, CS_2 going low and \overline{WE} going high, t_{WP} is measured from the beginning of write to the end of write.
2. t_{CW} is measured from the \overline{CS}_1 going low or CS_2 going high to the end of write.
3. t_{AS} is measured from the address valid to the beginning of write.
4. t_{WR} is measured from the end of write to the address change. t_{WR1} applied in case a write ends as \overline{CS}_1 or \overline{WE} going high t_{WR2} applied in case a write ends as CS_2 going to low.

DATA RETENTION WAVE FORM

CS₁ controlled

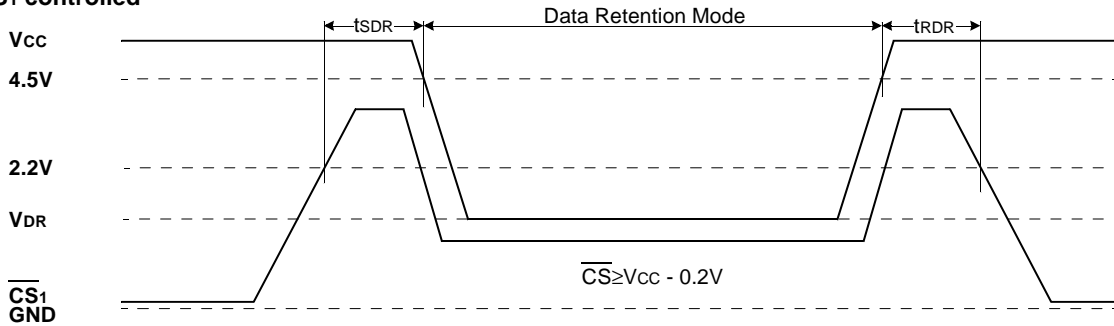

CS₂ controlled

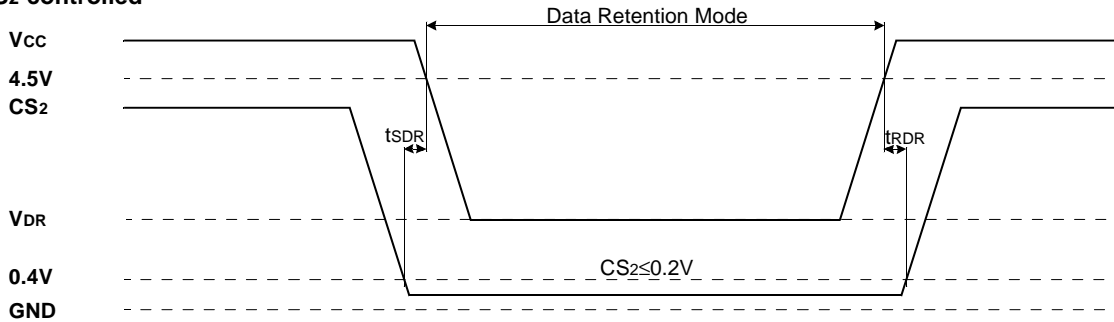

PACKAGE DIMENSIONS

32 DUAL INLINE PACKAGE (600mil)

Units: millimeters(inches)

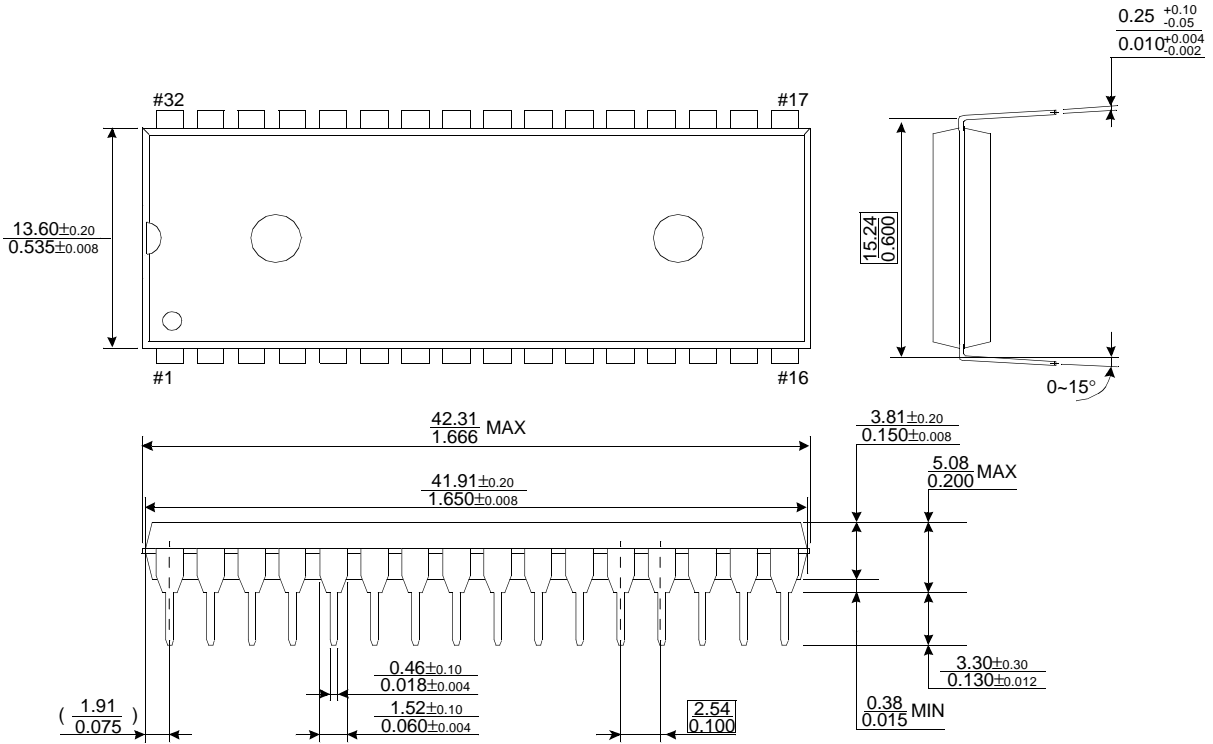

32 PLASTIC SMALL OUTLINE PACKAGE (525mil)

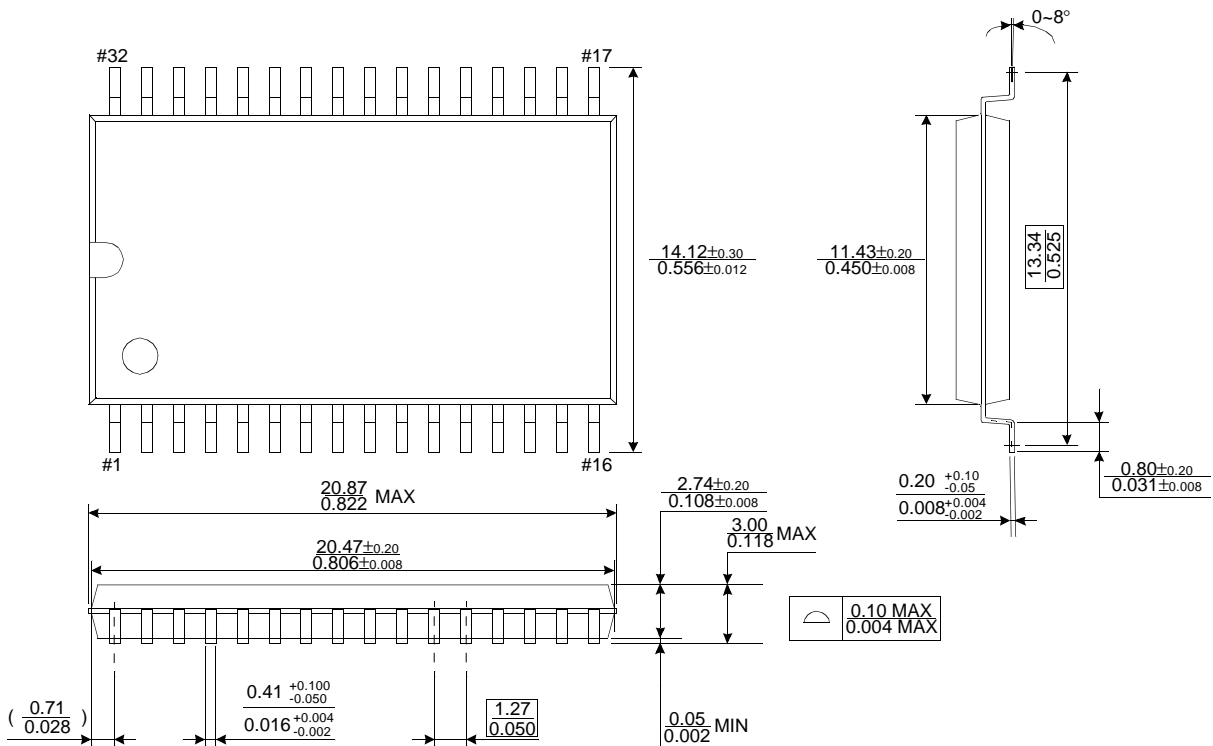

PACKAGE DIMENSIONS

Units: millimeters(inches)

32 PIN THIN SMALL OUTLINE PACKAGE TYPE I (0820F)

