

Sensorless Motor Control IC for Appliances

Features

- **MCE™ (Motion Control Engine) - Hardware based computation engine for high efficiency sinusoidal sensorless control of permanent magnet AC motor**
- **Supports both interior and surface permanent magnet motors**
- **Built-in hardware peripheral for single shunt current feedback reconstruction**
- **No external current or voltage sensing operational amplifier required**
- **Three/two-phase Space Vector PWM**
- **Analog output (PWM)**
- **Embedded 8-bit high speed microcontroller (8051) for flexible I/O and man-machine control**
- **JTAG programming port for emulation/debugger**
- **Serial communication interface (UART)**
- **I²C/SPI serial interface**
- **Watchdog timer with independent analog clock**
- **Three general purpose timers/counters**
- **Two special timers: periodic timer, capture timer**
- **External EEPROM and internal RAM facilitate debugging and code development**
- **Pin compatible with IRMCK371, OTP-ROM version**
- **1.8V/3.3V CMOS**

Product Summary

Maximum crystal frequency	60 MHz
Maximum internal clock (SYSCLK) frequency	128MHz
Sensorless control computation time	11 μsec typ
MCE™ computation data range	16 bit signed
Program RAM loaded from external EEPROM	48K bytes
Data RAM	8K bytes
GateKill latency (digital filtered)	2 μsec
PWM carrier frequency counter	16 bits/ SYSCLK
A/D input channels	4
A/D converter resolution	12 bits
A/D converter conversion speed	2 μsec
8051 instruction execution speed	2 SYSCLK
Analog output (PWM) resolution	8 bits
UART baud rate (typ)	57.6K bps
Number of I/O (max)	13
Package (lead-free)	QFP48

Description

IRMCF371 is a high performance RAM based motion control IC designed primarily for appliance applications. IRMCF371 is designed to achieve low cost and high performance control solutions for advanced inverterized appliance motor control. IRMCF371 contains two computation engines. One is Motion Control Engine (MCE™) for sensorless control of permanent magnet motors; the other is an 8-bit high-speed microcontroller (8051). Both computation engines are integrated into one monolithic chip. The MCE™ contains a collection of control elements such as Proportional plus Integral, Vector rotator, Angle estimator, Multiply/Divide, Low loss SVPWM, Single Shunt IFB. The user can program a motion control algorithm by connecting these control elements using a graphic compiler. Key components of the sensorless control algorithms, such as the Angle Estimator, are provided as complete pre-defined control blocks implemented in hardware. A unique analog/digital circuit and algorithm to fully support single shunt current reconstruction is also provided. The 8051 microcontroller performs 2-cycle instruction execution (60MIPS at 120MHz). The MCE and 8051 microcontroller are connected via dual port RAM to process signal monitoring and command input. An advanced graphic compiler for the MCE™ is seamlessly integrated into the MATLAB/Simulink environment, while third party JTAG based emulator tools are supported for 8051 developments. IRMCF371 comes with a small QFP48 pin lead-free package.

1 Overview

IRMCF371 is a new International Rectifier integrated circuit device primarily designed as a one-chip solution for complete inverter controlled appliance motor control applications. Unlike a traditional microcontroller or DSP, the IRMCF371 provides a built-in closed loop sensorless control algorithm using the unique Motion Control Engine (MCE™) for permanent magnet motors. The MCE™ consists of a collection of control elements, motion peripherals, a dedicated motion control sequencer and dual port RAM to map internal signal nodes. IRMCF371 also employs a unique single shunt current reconstruction circuit to eliminate additional analog/digital circuitry and enables a direct shunt resistor interface to the IC. Motion control programming is achieved using a dedicated graphical compiler integrated into the MATLAB/Simulink™ development environment. Sequencing, user interface, host communication, and upper layer control tasks can be implemented in the 8051 high-speed 8-bit microcontroller. The 8051 microcontroller is equipped with a JTAG port to facilitate emulation and debugging tools. Figure 1 shows a typical application schematic using the IRMCF371.

IRMCF371 is intended for development purpose and contains 48K bytes of RAM, which can be loaded from external EEPROM for 8051 program execution. For high volume production, IRMCK371 contains OTP ROM in place of program RAM to reduce the cost. Both IRMCF371 and IRMCK371 come in the same 48-pin QFP package with identical pin configuration to facilitate PC board layout and transition to mass production

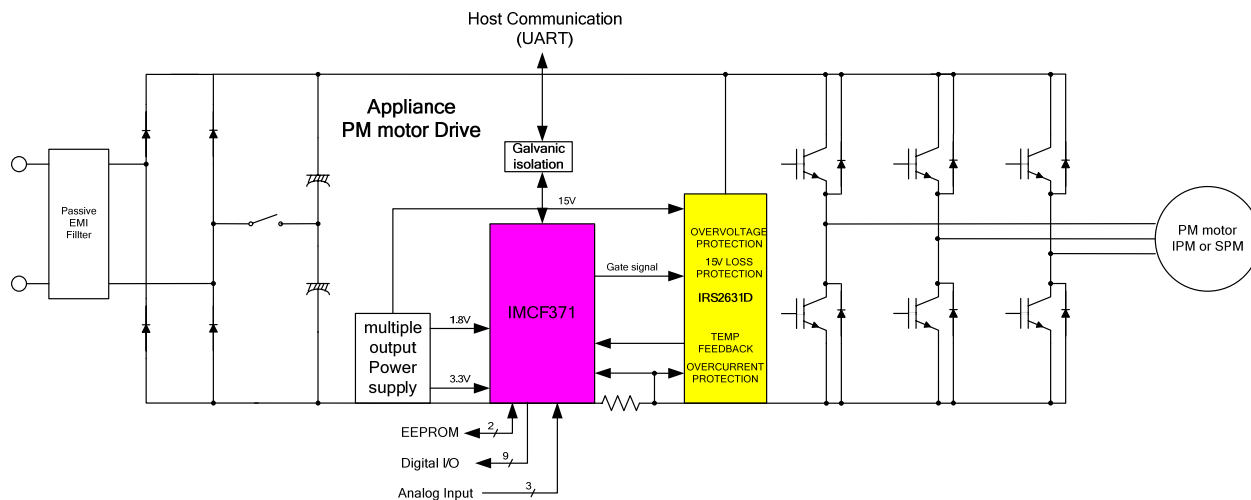

Figure 1. Typical Application Block Diagram Using IRMCF371

2 IRMCF371 Block Diagram and Main Functions

IRMCF371 block diagram is shown in Figure 2.

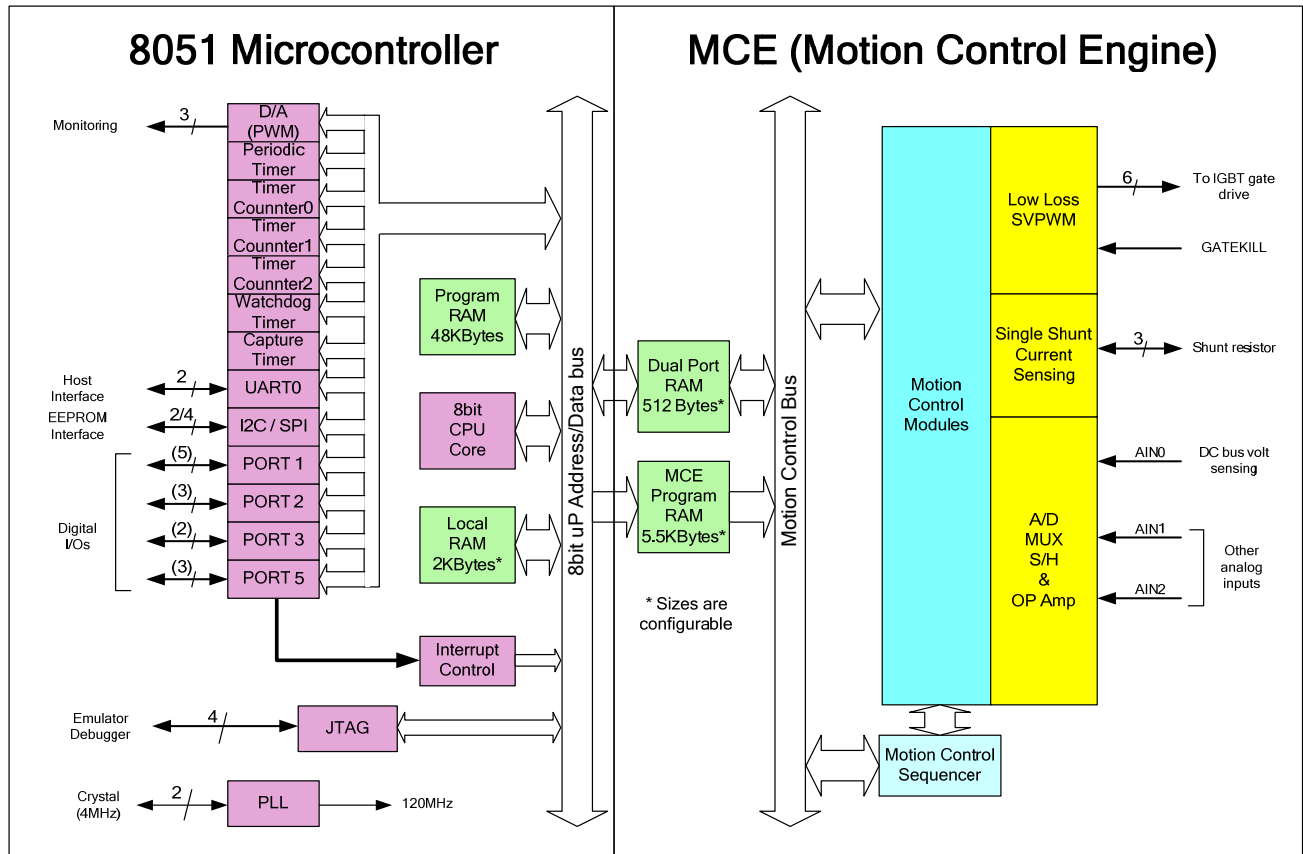

Figure 2. IRMCF371 Internal Block Diagram

IRMCF371 contains the following functions for sensorless AC motor control applications:

- Motion Control Engine (MCE™)
 - Proportional plus Integral block
 - Low pass filter
 - Differentiator and lag (high pass filter)
 - Ramp
 - Limit
 - Angle estimate (sensorless control)
 - Inverse Clark transformation
 - Vector rotator
 - Bit latch
 - Peak detect

- Transition
- Multiply-divide (signed and unsigned)
- Divide (signed and unsigned)
- Adder
- Subtractor
- Comparator
- Counter
- Accumulator
- Switch
- Shift
- ATAN (arc tangent)
- Function block (any curve fitting, nonlinear function)
- 16-bit wide Logic operations (AND, OR, XOR, NOT, NEGATE)
- MCE™ program and data memory (6K byte). ^{Note 1}
- MCE™ control sequencer

- 8051 microcontroller
 - Three 16-bit timer/counters
 - 16-bit periodic timer
 - 16-bit analog watchdog timer
 - 16-bit capture timer
 - Up to 13 discrete I/Os
 - Four-channel 12-bit A/D
 - One buffered channel for current sensing (0 – 1.2V input)
 - Three unbuffered channels (0 – 1.2V input)
 - JTAG port (4 pins)
 - One channel of analog output (8-bit PWM)
 - UART
 - I²C/SPI port
 - 48K byte program RAM loaded from external EEPROM
 - 2K byte data RAM. ^{Note 1}

Note 1: Total size of RAM is 8K byte including MCE program, MCE data, and 8051 data. Different sizes can be allocated depending on applications.

3 Pinout

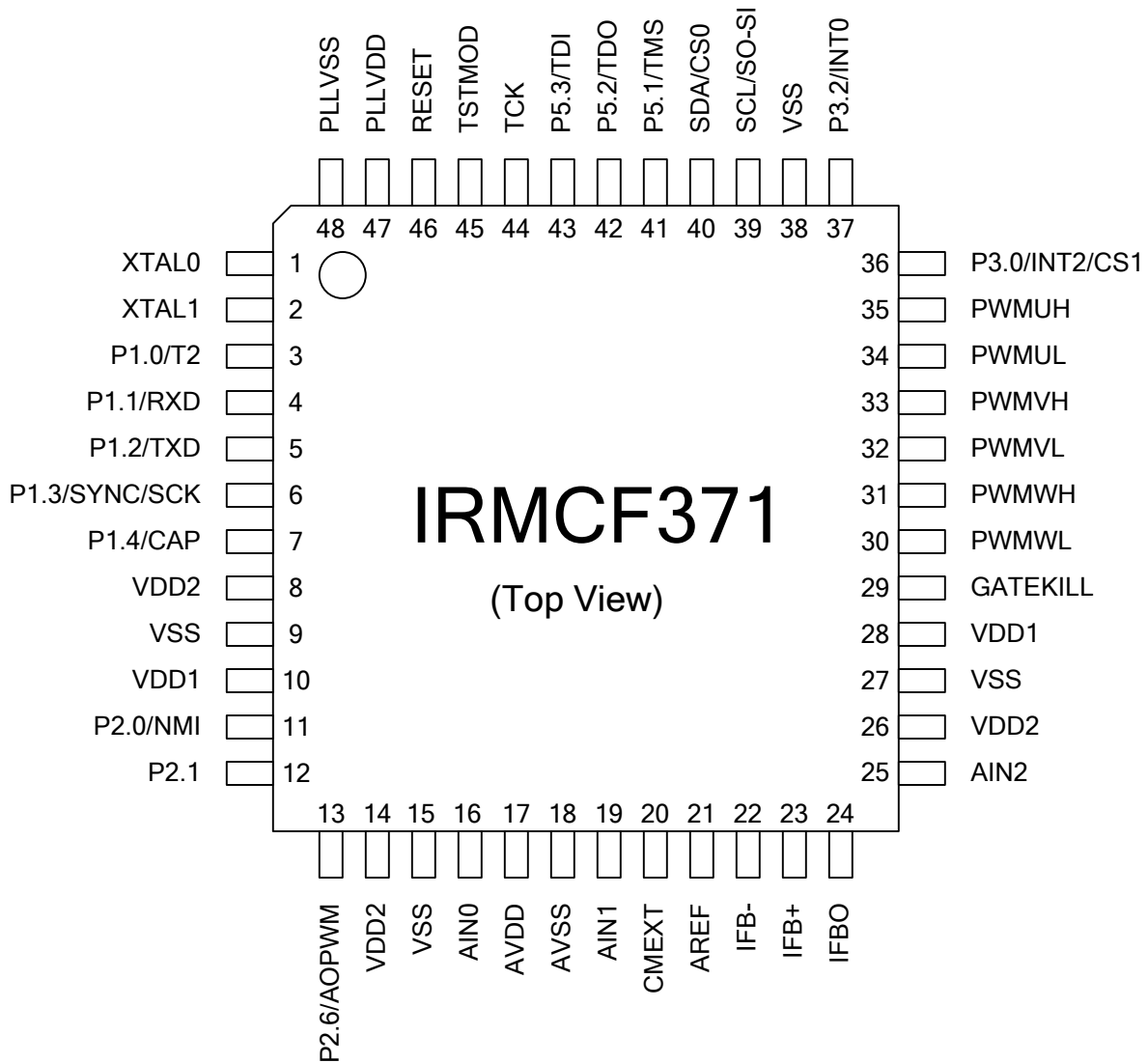

Figure 3. IRMCF371 Pin Configuration

4 Application Connections

Typical application connection is shown in Figure 4. All components necessary to implement a complete sensorless drive control algorithm are shown connected to IRMCF371.

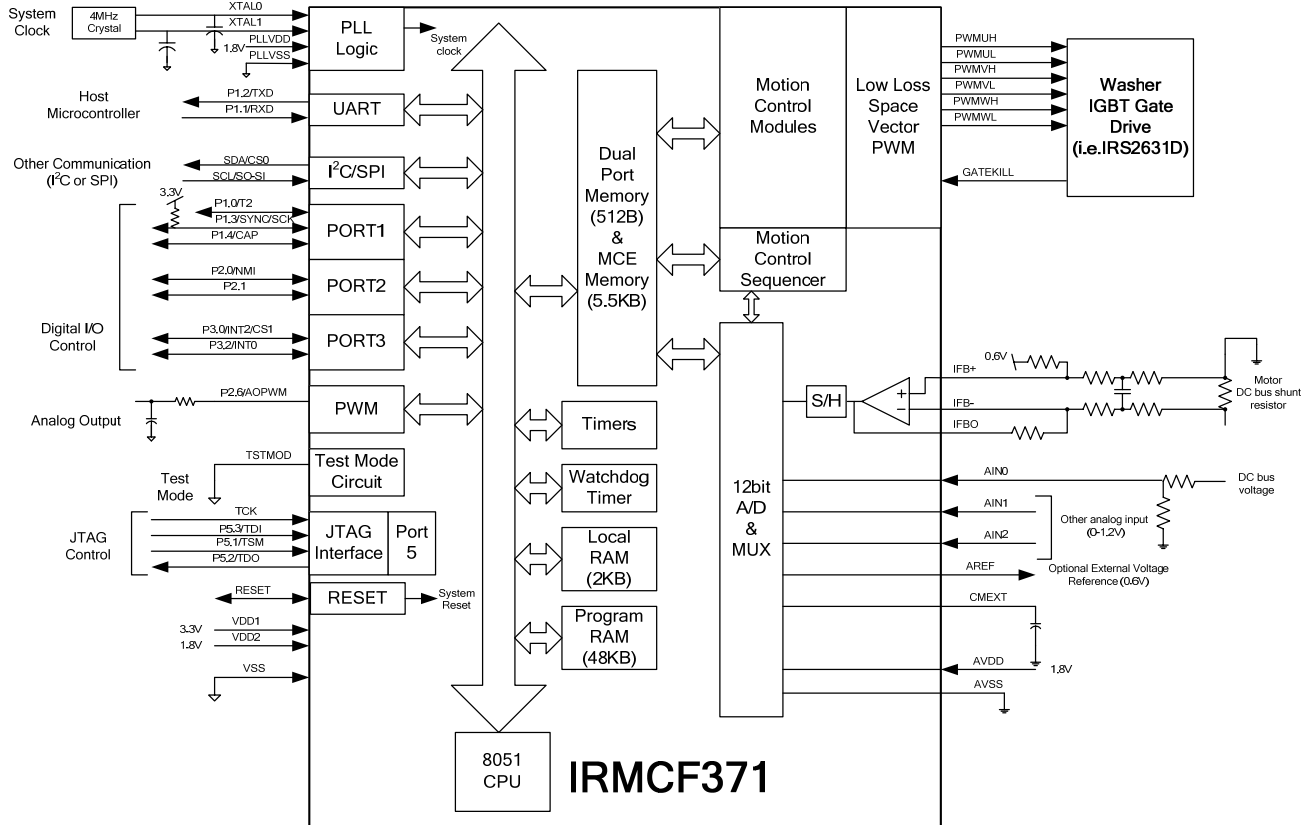
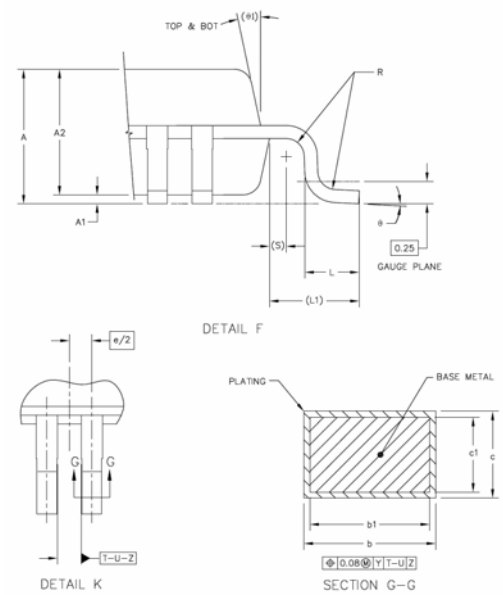
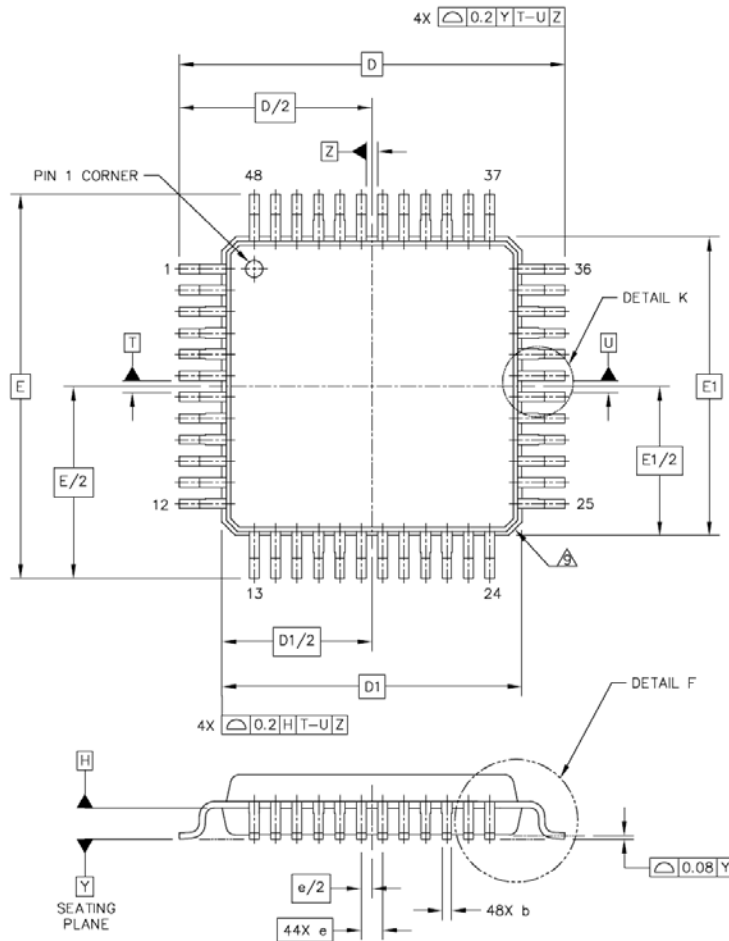

Figure 4. Application Connection of IRMCF371

5 Package Dimensions



NOTES:

1. DIMENSIONS ARE IN MILLIMETERS.
 2. INTERPRET DIMENSIONS AND TOLERANCES PER ASME Y14.5M-1994.
 3. DATUM PLANE H IS LOCATED AT BOTTOM OF LEAD AND IS COINCIDENT WITH THE LEAD WHERE THE LEAD EXITS THE PLASTIC BODY AT THE BOTTOM OF THE PARTING LINE.
 4. DATUM T, U AND Z TO BE DETERMINED AT DATUM PLANE H.
 5. DIMENSIONS D AND E TO BE DETERMINED AT SEATING PLANE Y.
 6. DIMENSIONS D1 AND E1 DO NOT INCLUDE MOLD PROTRUSION. ALLOWABLE PROTRUSION IS 0.25 PER SIDE. DIMENSIONS D1 AND E1 DO INCLUDE MOLD MISMATCH AND ARE DETERMINED AT DATUM PLANE H.
 7. DIMENSION b DOES NOT INCLUDE DAM BAR PROTRUSION. DAM BAR PROTRUSION SHALL NOT CAUSE THE b DIMENSION TO EXCEED 0.35.
 8. MINIMUM SOLDER PLATE THICKNESS SHALL BE 0.0076.
- △ EXACT SHAPE OF EACH CORNER IS OPTIONAL.

DIM	MIN	MAX	DIM	MIN	MAX	DIM	MIN	MAX
A	1.4	1.6	L1	1 REF				
A1	0.05	0.15	R	0.15	0.25			
A2	1.35	1.45	S	0.2 REF				
b	0.17	0.27	θ	1°	5°			
b1	0.17	0.23	θ1	12° REF				
c	0.09	0.2						
c1	0.09	0.16						
D		9 BSC						
D1		7 BSC						
e		0.5 BSC						
E		9 BSC						
E1		7 BSC						
L	0.5	0.7						

International
IOR Rectifier

The LQFP-48 is MSL3 qualified
This product has been designed and qualified for the industrial level
Qualification standards can be found at www.irf.com <<http://www.irf.com>>
IR WORLD HEADQUARTERS: 233 Kansas St., El Segundo, California 90245, Tel: (310) 252-7105
Data and specifications subject to change without notice. 11/03/2006

www.irf.com