

**LOW POWER LOW OFFSET VOLTAGE QUAD COMPARATORS****AS339/339A****General Description**

The AS339/339A consist of four independent precision voltage comparators with a typical offset voltage of 2.0mV and high gain. They are specifically designed to operate from a single power supply over wide range of voltages. Operation from split power supply is also possible and the low power supply current drain is independent of the magnitude of the power supply voltage.

The AS339/339A series are compatible with industry standard 339. AS339A has more stringent input offset voltage than AS339.

The AS339 is available in DIP-14, SOIC-14 and TSSOP-14 packages, AS339A is available in DIP-14 and SOIC-14 packages

Features

- Wide Supply Voltage Range
 - Single Supply: 2.0V to 36V
 - Dual Supplies: $\pm 1.0V$ to $\pm 18V$
- Low Supply Current Drain: 0.9mA
- Low Input Bias Current: 25nA (Typical)
- Low Input Offset Current: $\pm 5.0nA$ (Typical)
- Low Input Offset Voltage: 2.0mV (Typical)
- Input Common Mode Voltage Range Includes Ground
- Differential Input Voltage Range Equals to the Power Supply Voltage
- Low Output Saturation Voltage: 200mV at 4mA
- Open Collector Output

Applications

- Battery Charger
- Cordless Telephone
- Switching Power Supply
- DC-DC Module
- PC Motherboard
- Communication Equipment



Figure 1. Package Types of AS339/339A



LOW POWER LOW OFFSET VOLTAGE QUAD COMPARATORS AS339/339A

Pin Configuration

M/P/G Package
SOIC-14/DIP-14/TSSOP-14

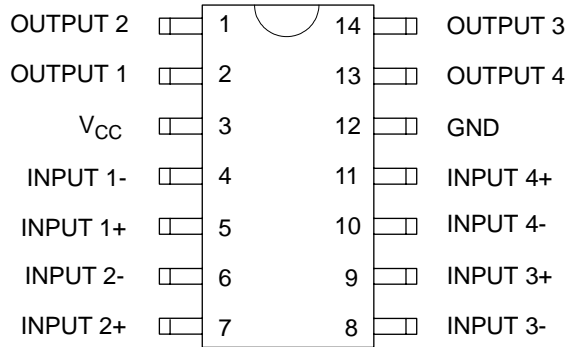

Figure 2. Pin Configuration of AS339/339A (Top View)

Functional Block Diagram

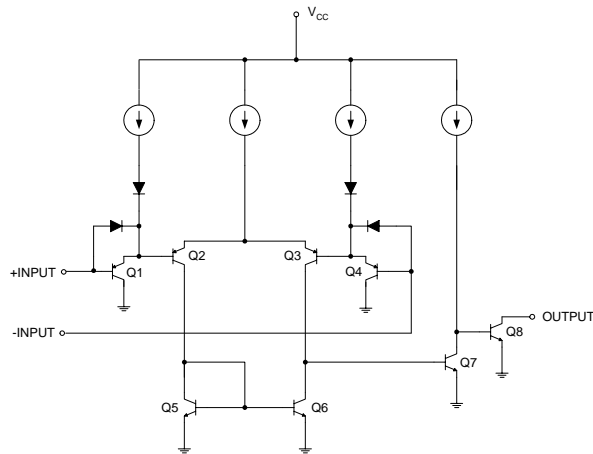
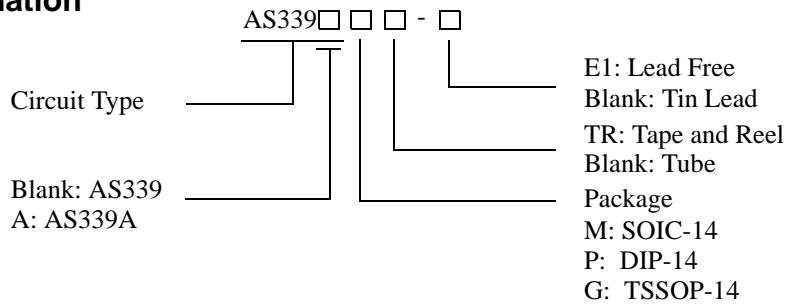

Figure 3. Functional Block Diagram of AS339/339A (Each comparator)

Ordering Information





LOW POWER LOW OFFSET VOLTAGE QUAD COMPARATORS AS339/339A

Ordering Information (Continued)

Package	Temperature Range	Part Number		Marking ID		Packing Type
		Tin Lead	Lead Free	Tin Lead	Lead Free	
SOIC-14	-40 to 85°C	AS339M	AS339M-E1	AS339M	AS339M-E1	Tube
		AS339MTR	AS339MTR-E1	AS339M	AS339M-E1	Tape & Reel
			AS339AM-E1		AS339AM-E1	Tube
			AS339AMTR-E1		AS339AM-E1	Tape & Reel
DIP-14		AS339P	AS339P-E1	AS339P	AS339P-E1	Tube
			AS339AP-E1		AS339AP-E1	Tube
TSSOP-14			AS339G-E1		EGS339	Tube
			AS339GTR-E1		EGS339	Tape & Reel

BCD Semiconductor's Pb-free products, as designated with "E1" suffix in the part number, are RoHS compliant.

Absolute Maximum Ratings (Note 1)

Parameter	Symbol	Value	Unit
Supply Voltage	V _{CC}	40	V
Differential Input Voltage	V _{ID}	40	V
Input Voltage	V _{IN}	-0.3 to 40	V
Input Current (V _{IN} <-0.3V) (Note 2)	I _{IN}	50	mA
Output Short-Circuit to Ground		Continuous	
Power Dissipation (T _A =25°C)	P _D	DIP-14	1050
		SOIC-14	890
		TSSOP-14	790
Operating Junction Temperature	T _J	150	°C
Storage Temperature Range	T _{STG}	-65 to 150	°C
Lead Temperature (Soldering, 10 Seconds)	T _{LEAD}	260	°C

Note 1: Stresses greater than those listed under "Absolute Maximum Ratings" may cause permanent damage to the device. These are stress ratings only, and functional operation of the device at these or any other conditions beyond those indicated under "Recommended Operating Conditions" is not implied. Exposure to "Absolute Maximum Ratings" for extended periods may affect device reliability.

Note 2: This input current will only exist when the voltage at any of the input leads is driven negative. It is due to the collector-base junction of the input PNP transistors becoming forward biased and thereby acting as input diode clamps. In addition to this diode action, there is also lateral NPN parasitic transistor action on the IC chip. This transistor action can cause the output voltages of the comparators to go to the V+ voltage level (or to ground for a large overdrive) for the time duration that an input is driven negative. This is not destructive and normal output states will re-establish when the input voltage, which was negative, again returns to a value greater than -0.3 V_{DC} (at 25°C).



LOW POWER LOW OFFSET VOLTAGE QUAD COMPARATORS AS339/339A

Recommended Operating Conditions

Parameter	Symbol	Min	Max	Unit
Supply Voltage	V_{CC}	2	36	V
Operating Temperature Range	T_A	-40	85	°C

Electrical Characteristics

Limits in standard typeface are for $T_A=25^\circ\text{C}$, **bold** typeface applies over $T_A=-40^\circ\text{C}$ to 85°C (Note 3), $V_{CC}=5\text{V}$, $\text{GND}=0\text{V}$, unless otherwise specified.

Parameter	Conditions	Min	Typ	Max	Unit	
Input Offset Voltage	$V_O=1.4\text{V}$, $R_S=0\Omega$, V_{CC} from 5V to 30V	AS339		2	5	mV
		AS339A		2	3	
Input Bias Current	I_{IN+} or I_{IN-} with output in Linear Range, $V_{CM}=0\text{V}$			25	250	nA
					400	
Input Offset Current	I_{IN+} - I_{IN-} , $V_{CM}=0\text{V}$			5.0	50	nA
					200	
Input Common Mode Voltage Range (Note 4)	$V_{CC}=30\text{V}$	0		$V_{CC}-1.5$	V	
Supply Current	$R_L=\infty$	$V_{CC}=5\text{V}$		0.9	2.0	mA
		$V_{CC}=30\text{V}$		1.2	2.5	
				3.0		
				3.5		
Voltage Gain	$R_L \geq 15\text{k}\Omega$, $V_{CC}=15\text{V}$, $V_O=1\text{V}$ to 11V	50	200		V/mV	
Large Signal Response Time	$V_{IN}=\text{TTL Logic Swing}$, $V_{REF}=1.4\text{V}$, $V_{RL}=5\text{V}$, $R_L=5.1\text{k}\Omega$		200		ns	
Response Time	$V_{RL}=5\text{V}$, $R_L=5.1\text{k}\Omega$		1.3		μs	
Output Sink Current	$V_{IN-}=1\text{V}$, $V_{IN+}=0$, $V_O=1.5\text{V}$	6.0	16		mA	
Output Leakage Current	$V_{IN-}=0\text{V}$, $V_{IN+}=1\text{V}$, $V_O=5\text{V}$		0.1		nA	
	$V_{IN-}=0\text{V}$, $V_{IN+}=1\text{V}$, $V_O=30\text{V}$			1	μA	
Saturation Voltage	$V_{IN-}=1\text{V}$, $V_{IN+}=0$, $I_{SINK} \leq 4\text{mA}$		200	400	mV	
				500		

Note 3: Limits over the full temperature are guaranteed by design, but not tested in production.

Note 4: The input common-mode voltage of either input signal voltage should not be allowed to go negatively by more than 0.3V (at 25°C). The upper end of the common-mode voltage range is $V_{CC}-1.5\text{V}$ (at 25°C), but either or both inputs can go to +18V without damages, independent of the magnitude of the V_{CC} .



LOW POWER LOW OFFSET VOLTAGE QUAD COMPARATORS AS339/339A

Typical Performance Characteristics

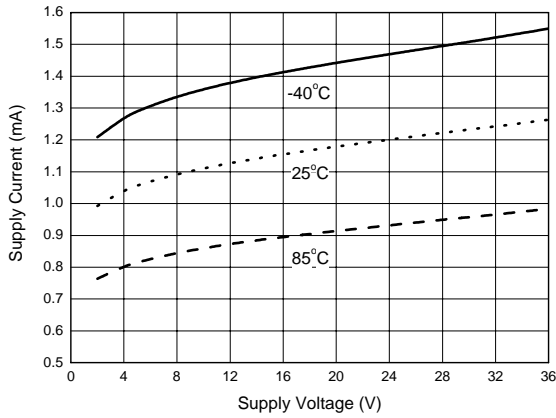

Figure 4. Supply Voltage vs. Supply Current

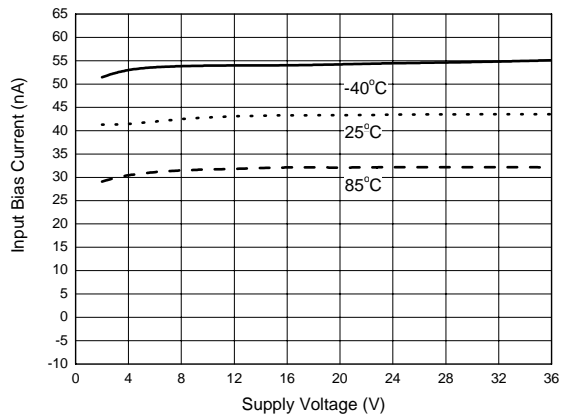

Figure 5. Supply Voltage vs. Input Bias Current

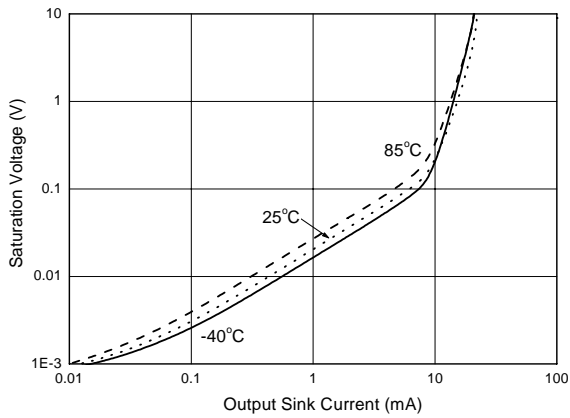

Figure 6. Output Sink Current vs. Saturation Voltage

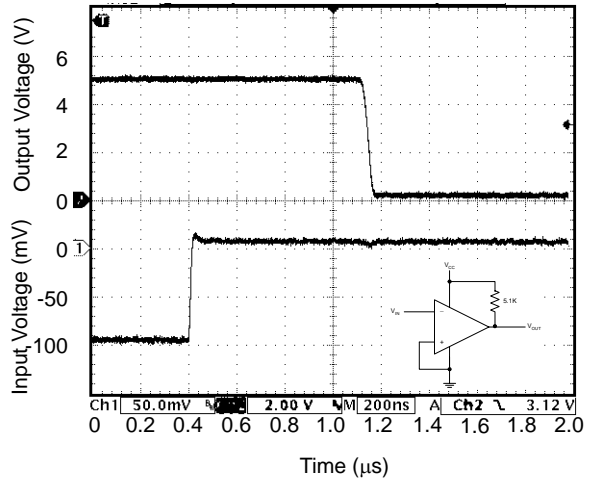

Figure 7. Response Time for 5mV Input Overdrive - Negative Transition



LOW POWER LOW OFFSET VOLTAGE QUAD COMPARATORS AS339/339A

Typical Performance Characteristics (Continued)

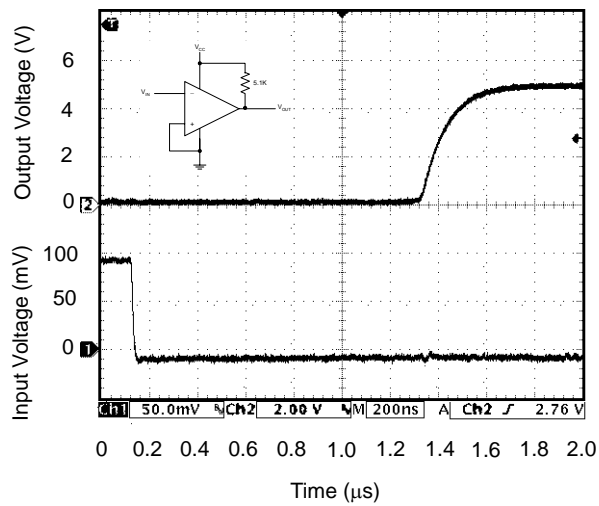

Figure 8. Response Time for 5mV Input Overdrive - Positive Transition



LOW POWER LOW OFFSET VOLTAGE QUAD COMPARATORS AS339/339A

Typical Applications

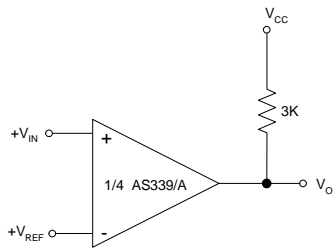

Figure 9. Basic Comparator

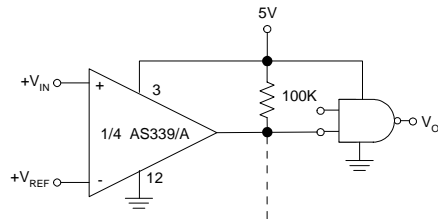

Figure 10. Driving CMOS

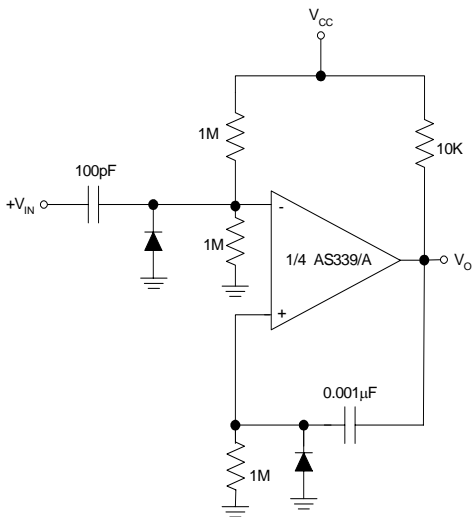

Figure 11. One Shot Multivibrator

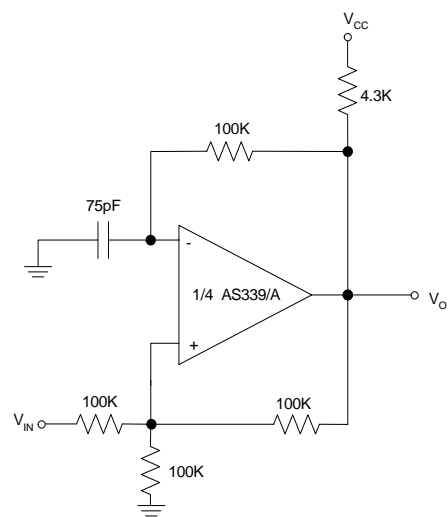

Figure 12. Squarewave Oscillator



LOW POWER LOW OFFSET VOLTAGE QUAD COMPARATORS AS339/339A

Mechanical Dimensions

DIP-14

Unit: mm(inch)

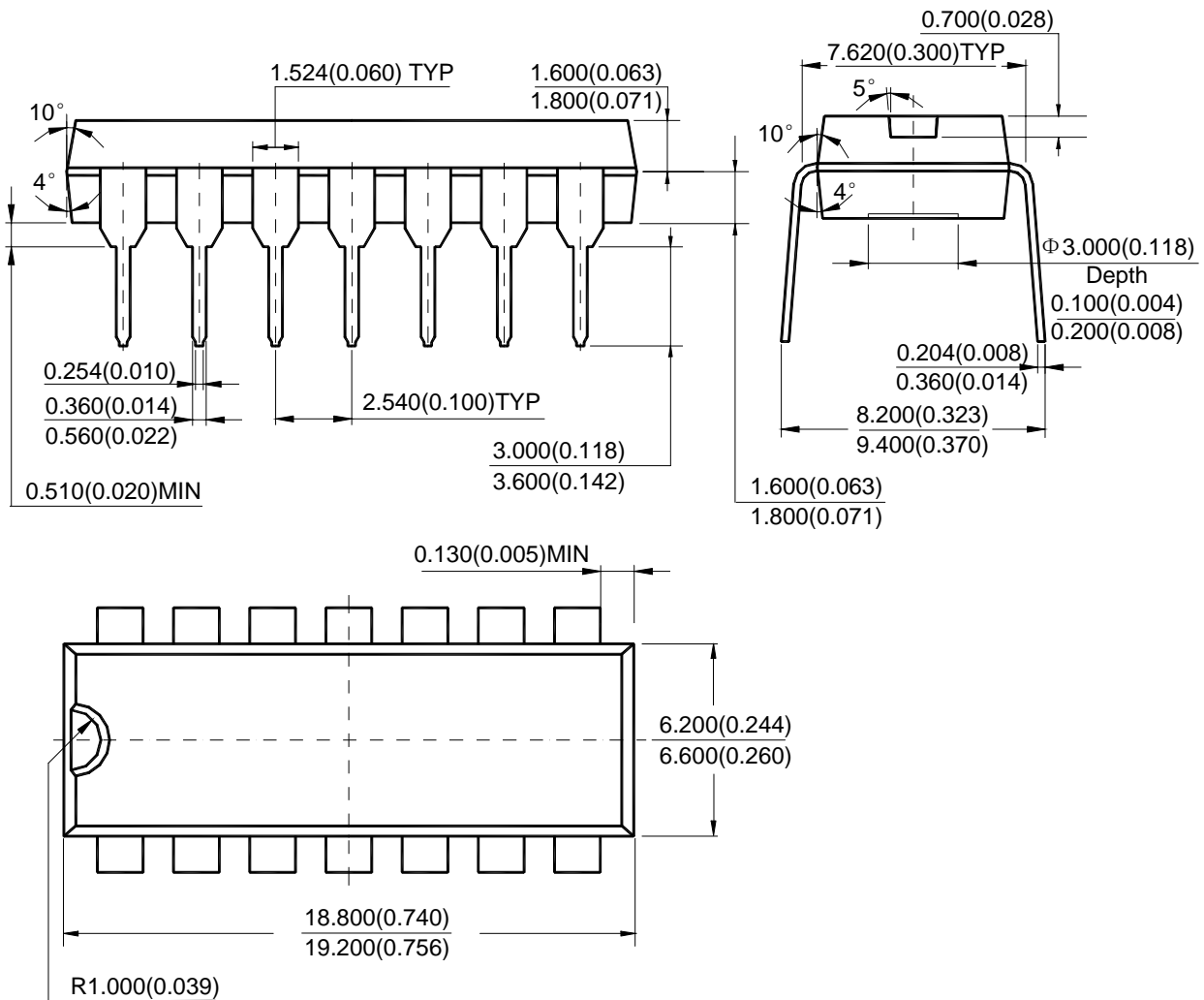



LOW POWER LOW OFFSET VOLTAGE QUAD COMPARATORS AS339/339A

Mechanical Dimensions (Continued)

SOIC-14

Unit: mm(inch)

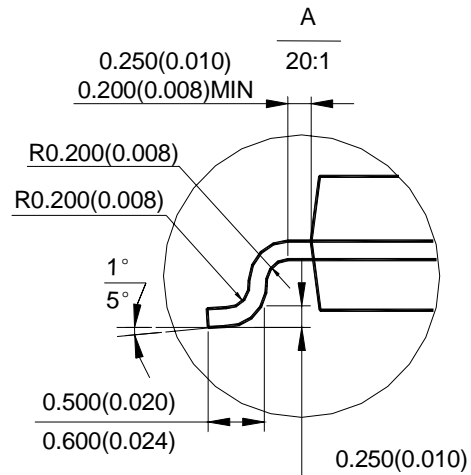
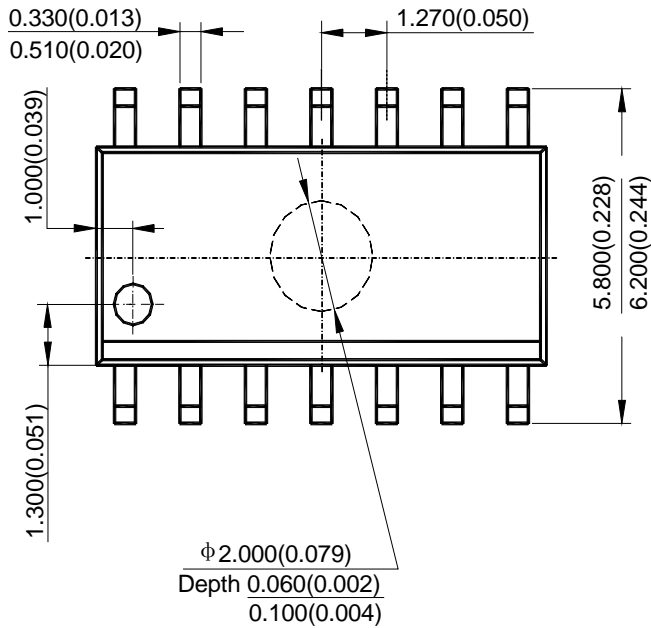
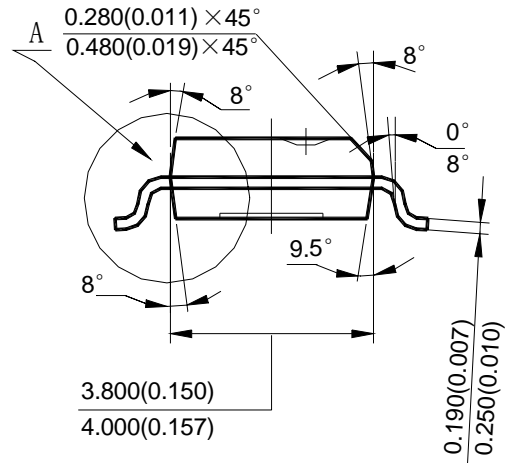
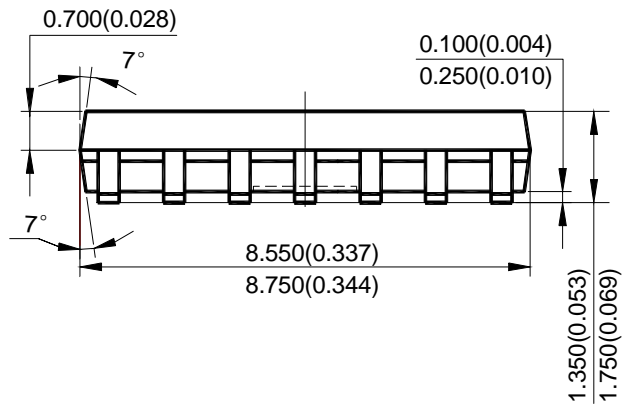



LOW POWER LOW OFFSET VOLTAGE QUAD COMPARATORS AS339/339A

Mechanical Dimensions (Continued)

TSSOP-14

Unit: mm(inch)

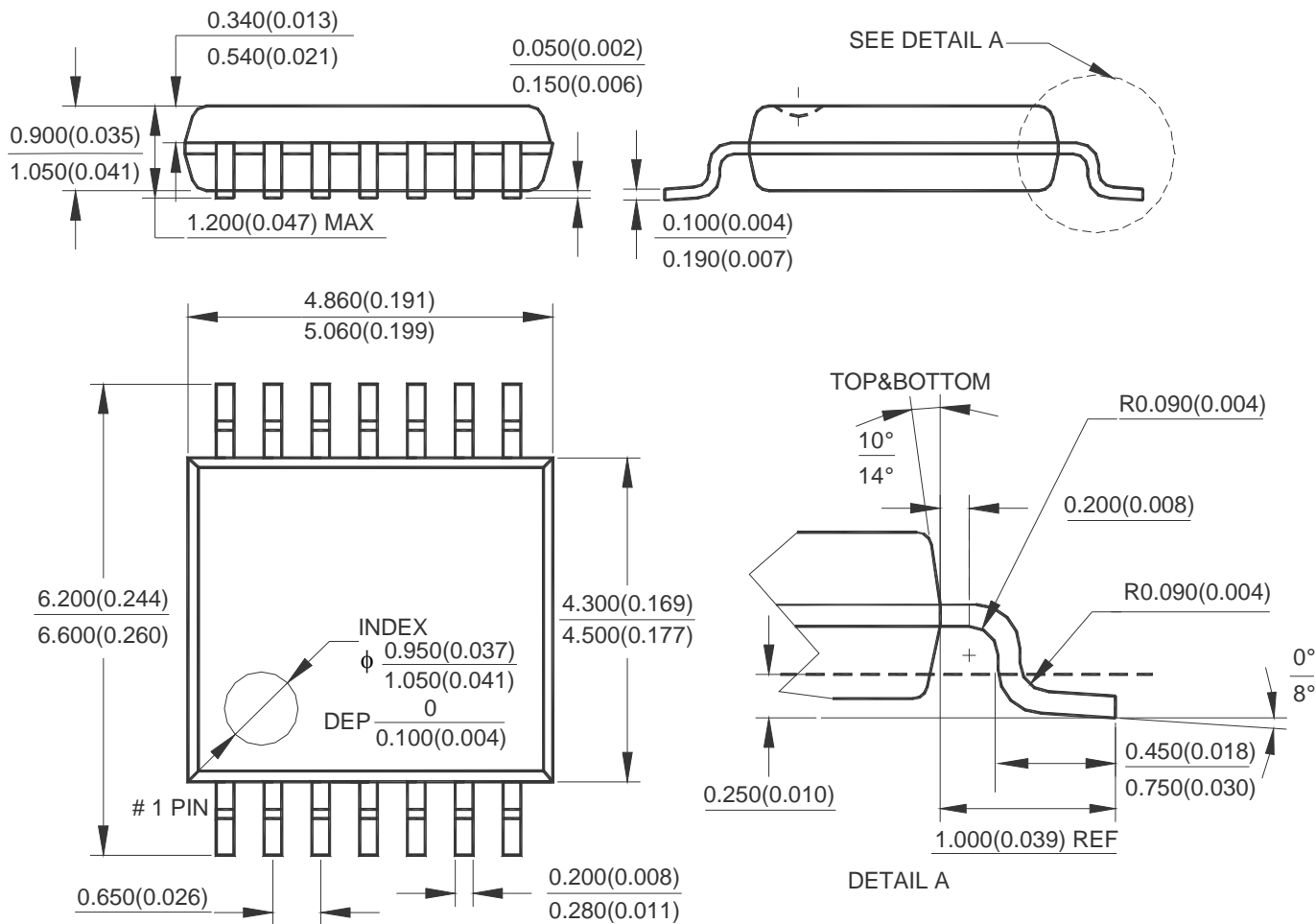



BCD Semiconductor Manufacturing Limited

<http://www.bcdsemi.com>

IMPORTANT NOTICE

BCD Semiconductor Manufacturing Limited reserves the right to make changes without further notice to any products or specifications herein. BCD Semiconductor Manufacturing Limited does not assume any responsibility for use of any its products for any particular purpose, nor does BCD Semiconductor Manufacturing Limited assume any liability arising out of the application or use of any its products or circuits. BCD Semiconductor Manufacturing Limited does not convey any license under its patent rights or other rights nor the rights of others.

MAIN SITE

BCD Semiconductor Manufacturing Limited
- Wafer Fab
Shanghai SIM-BCD Semiconductor Manufacturing Limited
800, Yi Shan Road, Shanghai 200233, China
Tel: +86-21-6485 1491, Fax: +86-21-5450 0008

BCD Semiconductor Manufacturing Limited
- IC Design Group
Advanced Analog Circuits (Shanghai) Corporation
8F, Zone B, 900, Yi Shan Road, Shanghai 200233, China
Tel: +86-21-6495 9539, Fax: +86-21-6485 9673

REGIONAL SALES OFFICE

Shenzhen Office
Shanghai SIM-BCD Semiconductor Manufacturing Co., Ltd. Shenzhen Office
Advanced Analog Circuits (Shanghai) Corporation Shenzhen Office
27B, Tower C, 2070, Middle Shen Nan Road, Shenzhen 518031, China
Tel: +86-755-8368 3987, Fax: +86-755-8368 3166

Taiwan Office
BCD Semiconductor (Taiwan) Company Limited
4F, 298-1, Rui Guang Road, Nei-Hu District, Taipei,
Taiwan
Tel: +886-2-2656 2808, Fax: +886-2-2656 2806

USA Office
BCD Semiconductor Corporation
3170 De La Cruz Blvd., Suite 105, Santa Clara,
CA 95054-2411, U.S.A
Tel: +1-408-988 6388, Fax: +1-408-988 6386