

THREE-TERMINAL NEGATIVE VOLTAGE REGULATORS

The LM79L00 Series negative voltage regulators are inexpensive, easy-to-use devices suitable for numerous applications requiring up to 100 mA. Like the higher powered LM7900 Series negative regulators, this series features thermal shutdown and current limiting, making them remarkably rugged. In

most applications, no external components are required for operation.

The LM79L00 devices are useful for on-card regulation or any other application where a regulated negative voltage at a modest current level is needed. These regulators offer substantial advantage over the common resistor/zener diode approach.

FEATURES

- No External Components Required
- Internal Short-Circuit Current Limiting
- Internal Thermal Overload Protection
- Low Cost
- Complementary Positive Regulators Offered (LM78L00 Series)
- Available in $\pm 2\%$ Voltage Tolerance

PIN ARRANGEMENT

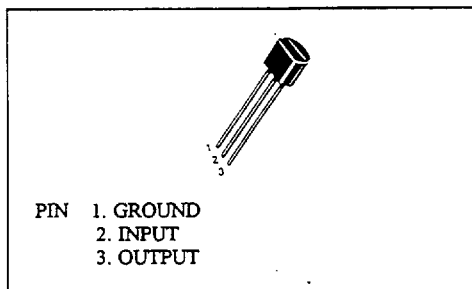

CIRCUIT SCHEMATIC

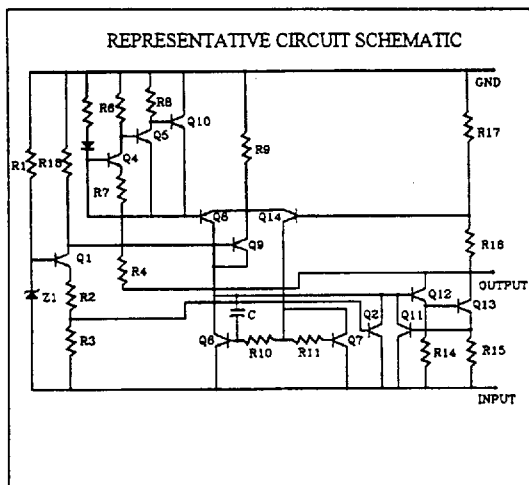

TYPICAL CONNECTING CIRCUIT

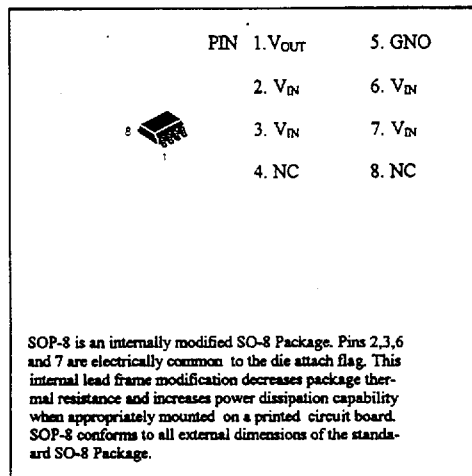

ABSOLUTE MAXIMUM RATINGS ($T_A = +25^\circ\text{C}$)

Rating	Symbol	LM79L00 Series	Unit
Input Voltage	$V_{in} *1$	- 30	V
Input Voltage	$V_{in} *2$	- 35	V
Input Voltage	$V_{in} *3$	- 40	V
Storage Temperature	T_{stg}	- 65 to 150	$^\circ\text{C}$
Junction Temperature Range	T_J	0 to 150	$^\circ\text{C}$

Note: *1. LM79L05

*2. LM79L12, LM79L15, LM79L18

*3. LM79L24

LM79L05 Series ELECTRICAL CHARACTERISTICS

($V_I = -10\text{V}$, $I_O = 40\text{mA}$, $C_I = 0.33\ \mu\text{F}$, $C_O = 0.1\ \mu\text{F}$, $0^\circ\text{C} < T_J < 125^\circ\text{C}$ unless otherwise noted.)

Characteristic	Symbol	LM79L05			Unit
		Min	Typ	Max	
Output Voltage ($T_J = +25^\circ\text{C}$)	V_O	- 4.9	- 5.0	- 5.1	Vdc
Line Regulation ($T_J = +25^\circ\text{C}$) - 7.0 Vdc $\geq V_I \geq$ -20 Vdc - 8.0 Vdc $\geq V_I \geq$ -20 Vdc	REGline	--	--	150 100	mV
Load Regulation $T_J = +25^\circ\text{C}$, $1.0\text{mA} \leq I_O \leq 100\text{mA}$ $1.0\text{mA} \leq I_O \leq 40\text{mA}$	REGload	--	--	60 30	mV
Output Voltage - 7.0 Vdc $\geq V_I \geq$ -20 Vdc, $1.0\text{mA} \leq I_O \leq 40\text{mA}$ $V_I = -10\text{Vdc}$, $1.0\text{mA} \leq I_O \leq 70\text{mA}$	V_O	- 4.9 - 4.9	--	- 5.1 - 5.1	Vdc
Input Bias Current ($T_J = +25^\circ\text{C}$) ($T_J = +125^\circ\text{C}$)	I_{IB}	--	--	6.0 5.5	mA
Input Bias Current Change - 8.0 Vdc $\geq V_I \geq$ -20 Vdc $1.0\text{mA} \leq I_O \leq 40\text{mA}$	ΔI_{IB}	--	--	1.5 0.1	mA
Output Noise Voltage ($T_A = +25^\circ\text{C}$, $10\text{Hz} \leq f \leq 100\text{kHz}$)	V_n	--	40	--	μV
Ripple Rejection (- 8.0 $\geq V_I \geq$ 18 Vdc, $f = 120\text{Hz}$, $T_J = 25^\circ\text{C}$)	RR	41	49	--	dB
Dropout Voltage $I_O = 40\text{mA}$, $T_J = +25^\circ\text{C}$	$ V_I - V_O $	--	1.7	--	Vdc

LM79L12 Series ELECTRICAL CHARACTERISTICS

($V_I = -19V$, $I_O = 40$ mA, $C_I = 0.33$ μ F, $C_O = 0.1$ μ F, $0^\circ\text{C} < T_J < 125^\circ\text{C}$ unless otherwise noted.)

Characteristic	Symbol	LM79L12			Unit
		Min	Typ	Max	
Output Voltage ($T_J = +25^\circ\text{C}$)	V_O	-11.76	-12	-12.24	Vdc
Line Regulation ($T_J = +25^\circ\text{C}$) -14.5 Vdc $\geq V_I \geq -27$ Vdc -16 Vdc $\geq V_I \geq -27$ Vdc	REGline	--	--	250 200	mV
Load Regulation $T_J = +25^\circ\text{C}$, 1.0 mA $\leq I_O \leq 100$ mA 1.0 mA $\leq I_O \leq 40$ mA	REGload	--	--	100 50	mV
Output Voltage -14.5 Vdc $\geq V_I \geq -27$ Vdc, 1.0 mA $\leq I_O \leq 40$ mA $V_I = -19$ Vdc, 1.0 mA $\leq I_O \leq 70$ mA	V_O	-11.66 -11.66	--	-12.34 -12.34	Vdc
Input Bias Current ($T_J = +25^\circ\text{C}$) ($T_J = +125^\circ\text{C}$)	I_{IB}	--	--	6.5 6.0	mA
Input Bias Current Change -16 Vdc $\geq V_I \geq -27$ Vdc 1.0 mA $\leq I_O \leq 40$ mA	ΔI_{IB}	--	--	1.5 0.1	mA
Output Noise Voltage ($T_A = +25^\circ\text{C}$, 10 Hz $\leq f \leq 100$ kHz)	V_n	--	80	--	μ V
Ripple Rejection ($-15 \geq V_I \geq -25$ Vdc, $f = 120$ Hz, $T_J = 25^\circ\text{C}$)	RR	37	42	--	dB
Dropout Voltage $I_O = 40$ mA, $T_J = +25^\circ\text{C}$	$ V_I - V_O $	--	1.7	--	Vdc

LM79L15 Series ELECTRICAL CHARACTERISTICS

($V_I = -23V$, $I_O = 40$ mA, $C_I = 0.33$ μ F, $C_O = 0.1$ μ F, $0^\circ\text{C} < T_J < 125^\circ\text{C}$ unless otherwise noted.)

Characteristic	Symbol	LM79L15			Unit
		Min	Typ	Max	
Output Voltage ($T_J = +25^\circ\text{C}$)	V_O	-14.7	-15	-15.3	Vdc
Line Regulation ($T_J = +25^\circ\text{C}$) -17.5 Vdc $\geq V_I \geq -30$ Vdc -20 Vdc $\geq V_I \geq -30$ Vdc	REGline	--	--	300 250	mV
Load Regulation $T_J = +25^\circ\text{C}$, 1.0 mA $\leq I_O \leq 100$ mA 1.0 mA $\leq I_O \leq 40$ mA	REGload	--	--	150 75	mV
Output Voltage -17.5 Vdc $\geq V_I \geq -30$ Vdc, 1.0 mA $\leq I_O \leq 40$ mA $V_I = -23$ Vdc, 1.0 mA $\leq I_O \leq 70$ mA	V_O	-14.25 -14.25	--	-15.75 -15.75	Vdc
Input Bias Current ($T_J = +25^\circ\text{C}$) ($T_J = +125^\circ\text{C}$)	I_{IB}	--	--	6.5 6.0	mA
Input Bias Current Change -20 Vdc $\geq V_I \geq -30$ Vdc 1.0 mA $\leq I_O \leq 40$ mA	ΔI_{IB}	--	--	1.5 0.1	mA
Output Noise Voltage ($T_A = +25^\circ\text{C}$, 10 Hz $\leq f \leq 100$ kHz)	V_n	--	90	--	μ V
Ripple Rejection (-18.5 Vdc $\leq V_I \leq -28.5$ Vdc, $f = 120$ Hz)	RR	34	39	--	dB
Dropout Voltage $I_O = 40$ mA, $T_J = +25^\circ\text{C}$	$ V_I - V_O $	--	1.7	--	Vdc

LM79L18 Series ELECTRICAL CHARACTERISTICS

($V_I = -27V$, $I_O = 40$ mA, $C_I = 0.33$ μ F, $C_O = 0.1$ μ F, $0^\circ C < T_J < 125^\circ C$ unless otherwise noted.)

Characteristic	Symbol	LM79L18			Unit
		Min	Typ	Max	
Output Voltage ($T_J = +25^\circ C$)	V_O	-17.64	-18	-18.36	Vdc
Line Regulation ($T_J = +25^\circ C$) -20.7 Vdc $\geq V_I \geq -33$ Vdc -21.4 Vdc $\geq V_I \geq -33$ Vdc -22 Vdc $\geq V_I \geq -33$ Vdc -21 Vdc $\geq V_I \geq -33$ Vdc	REGline	--	--	325	mV
Load Regulation $T_J = +25^\circ C$, 1.0 mA $\leq I_O \leq 100$ mA 1.0 mA $\leq I_O \leq 40$ mA	REGload	--	--	170 85	mV
Output Voltage -20.7 Vdc $\geq V_I \geq -33$ Vdc, 1.0 mA $\leq I_O \leq 40$ mA -21.4 Vdc $\geq V_I \geq -33$ Vdc, 1.0 mA $\leq I_O \leq 40$ mA $V_I = -27$ Vdc, 1.0 mA $\leq I_O \leq 70$ mA	V_O	-17.44 -- -17.1	-- -- --	-18.56 -- -1.89	Vdc
Input Bias Current ($T_J = +25^\circ C$) ($T_J = +125^\circ C$)	I_{IB}	-- --	-- --	6.5 6.0	mA
Input Bias Current Change -21 Vdc $\geq V_I \geq -33$ Vdc -27 Vdc $\geq V_I \geq -33$ Vdc 1.0 mA $\leq I_O \leq 40$ mA	ΔI_{IB}	-- -- --	-- -- --	1.5 -- 0.1	mA
Output Noise Voltage ($T_A = +25^\circ C$, 10 Hz $\leq f \leq 100$ kHz)	V_n	--	150	--	μ V
Ripple Rejection ($-23 \geq V_I \geq -33$ Vdc, $f = 120$ Hz, $T_J = 25^\circ C$)	RR	33	48	--	dB
Dropout Voltage $I_O = 40$ mA, $T_J = +25^\circ C$	$ V_I - V_O $	--	1.7	--	Vdc

LM79L24 Series ELECTRICAL CHARACTERISTICS

($V_I = -33\text{V}$, $I_O = 40\text{ mA}$, $C_I = 0.33\ \mu\text{F}$, $C_O = 0.1\ \mu\text{F}$, $0^\circ\text{C} < T_J < 125^\circ\text{C}$ unless otherwise noted.)

Characteristic	Symbol	LM79L24			Unit
		Min	Typ	Max	
Output Voltage ($T_J = +25^\circ\text{C}$)	V_O	-23.52	-24	-24.48	Vdc
Line Regulation ($T_J = +25^\circ\text{C}$)	REGline	--	--	350	mV
-27 Vdc $\geq V_I \geq -38\text{ Vdc}$		--	--	--	
-27.5Vdc $\geq V_I \geq -38\text{ Vdc}$		--	--	300	
-28 Vdc $\geq V_I \geq -38\text{ Vdc}$		--	--	--	
Load Regulation	REGload	--	--	200	mV
$T_J = +25^\circ\text{C}$, $1.0\text{ mA} \leq I_O \leq 100\text{ mA}$		--	--	100	
$1.0\text{ mA} \leq I_O \leq 40\text{ mA}$		--	--	--	
Output Voltage	V_O	-23.32	--	-24.68	Vdc
-27 Vdc $\geq V_I \geq -38\text{ Vdc}$, $1.0\text{ mA} \leq I_O \leq 40\text{ mA}$		--	--	--	
-28 Vdc $\geq V_I \geq -38\text{ Vdc}$, $1.0\text{ mA} \leq I_O \leq 40\text{ mA}$		--	--	--	
$V_I = -33\text{ Vdc}$, $1.0\text{ mA} \leq I_O \leq 70\text{ mA}$		-23.32	--	-24.68	
Input Bias Current	I_{IB}	--	--	6.5	mA
($T_J = +25^\circ\text{C}$)		--	--	6.0	
($T_J = +125^\circ\text{C}$)		--	--	--	
Input Bias Current Change	ΔI_{IB}	--	--	1.5	mA
-28 Vdc $\geq V_I \geq -38\text{ Vdc}$		--	--	0.1	
$1.0\text{ mA} \leq I_O \leq 40\text{ mA}$		--	--	--	
Output Noise Voltage	V_n	--	200	--	μV
($T_A = +25^\circ\text{C}$, $10\text{ Hz} \leq f \leq 100\text{ kHz}$)		--	--	--	
Ripple Rejection	RR	31	47	--	dB
($-29 \leq V_I \leq -35\text{ Vdc}$, $f = 120\text{ Hz}$, $T_J = 25^\circ\text{C}$)		--	--	--	
Dropout Voltage	$ V_I - V_O $	--	1.7	--	Vdc
$I_O = 40\text{ mA}$, $T_J = +25^\circ\text{C}$		--	--	--	

APPLICATIONS INFORMATION

Design Considerations

The LM79L00 Series of fixed voltage regulators are designed with Thermal Overload Protection that shuts down the circuit when subjected to an excessive power overload condition, Internal Short-Circuit Protection that limits the maximum current the circuit will pass.

In many low current applications, compensation capacitors are not required. However, it is recommended that the regulator input be bypassed with a capacitor if the regulator is connected to the power supply filter with long

FIGURE 1 - POSITIVE AND NEGATIVE REGULATOR

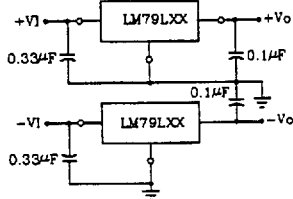

wire lengths, or if the output load capacitance is large. An input bypass capacitor should be selected to provide good high-frequency characteristics to insure stable operation under all load conditions. A 0.33 μF or larger tantalum, mylar, or other capacitor having low internal impedance at high frequencies should be used to minimize ground loops and lead resistance drops since the regulator has no external sense lead. Bypassing the output is also recommended.

FIGURE 2-STANDARD APPLICATION

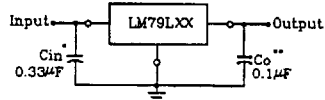

A common ground is required between the input and the output voltages. The input voltage must remain typically 2.0 V above the output voltage even during the low point on the input ripple voltage.

* = C_I is required if regulator is located an appreciable distance from power supply filter.

** = C_O improves stability and transient response.

FIGURE 3-DROPOUT CHARACTERISTICS

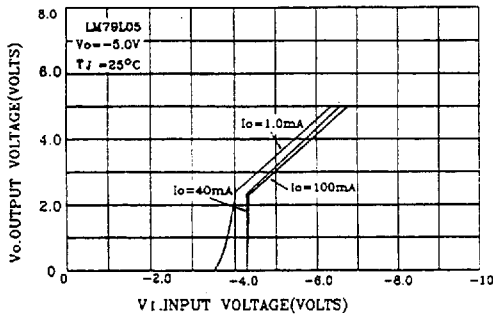

FIGURE 4-DROPOUT VOLTAGE versus JUNCTION TEMPERATURE

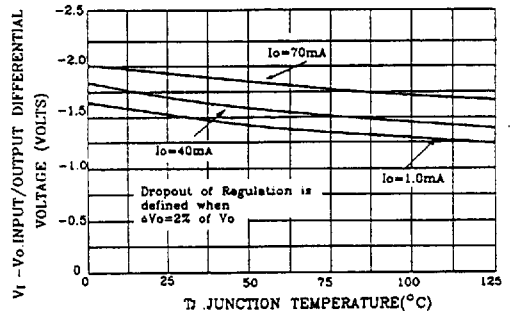

FIGURE 5-INPUT BIAS CURRENT versus AMBIENT TEMPERATURE

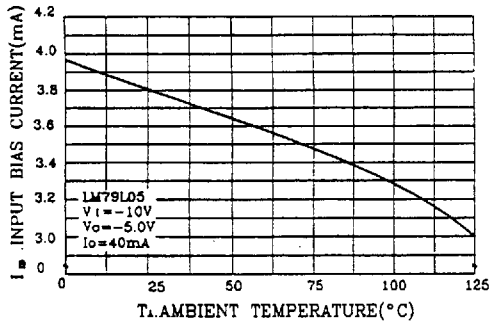

FIGURE 6-INPUT BIAS CURRENT versus INPUT VOLTAGE

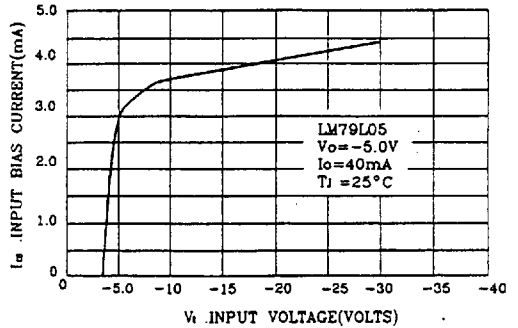

FIGURE 7-MAXIMUM AVERAGE POWER DISSIPATION versus AMBIENT TEMPERATURE -TO-92 Type Package

