



## TDA2050

LINEAR INTEGRATED CIRCUIT

### 32W HI-FI AUDIO POWER AMPLIFIER

#### DESCRIPTION

The UTC TDA2050 is a monolithic integrated circuit with high power capability and is designed to use as an class AB audio amplifier. It can deliver typically 50W music power into 4Ω load over 1 sec at  $V_s=22.5V$ ,  $f = 1KHz$ .

The device is most suitable for both Hi-Fi and high class TV sets on the strength of its high supply voltage and very low harmonic and crossover distortion.

#### FEATURES

- \* High output power (50W Music Power IEC 268.3 Rules)
- \* High operating supply voltage (50V)
- \* Single or split supply operations
- \* Very low distortion
- \* Short circuit protection (OUT to GND)
- \* Thermal shutdown

#### ORDERING INFORMATION

Ordering Number		Package	Packing
Normal	Lead Free Plating		
TDA2050-TB5-T	TDA2050L-TB5-T	TO-220B	Tube

#### PIN CONFIGURATION

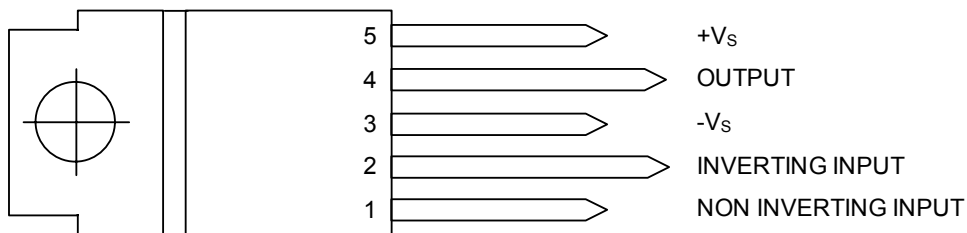

\*TAB CONNECTED TO PIN 3

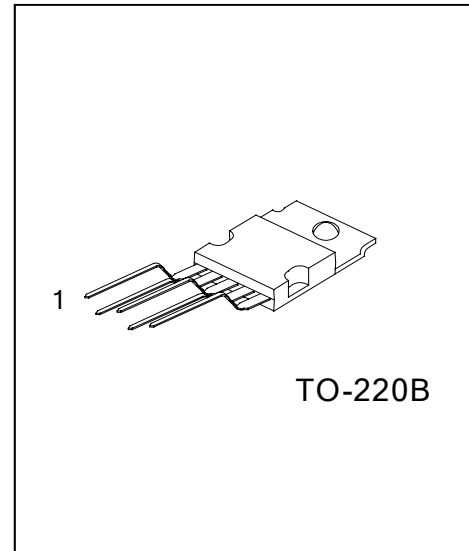

\*Pb-free plating product number: TDA2050L

## ■ BLOCK DIAGRAM

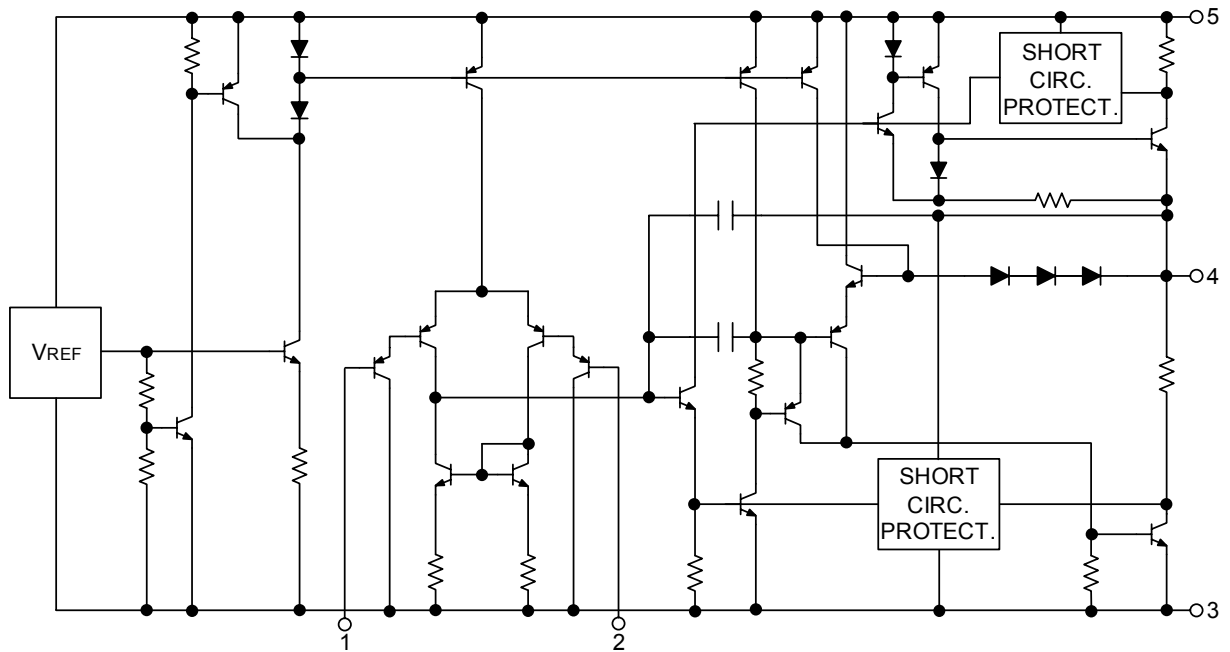

### ■ ABSOLUTE MAXIMUM RATINGS

PARAMETER	SYMBOL	RATINGS	UNIT
Supply Voltage	$V_S$	$\pm 25$	V
Input Voltage	$V_{IN}$	$V_S$	
Differential Input Voltage	$V_{IN(DIFF)}$	$\pm 15$	$^{\circ}C$
Output Peak Current (internally limited)	$I_{OUT}$	5	$^{\circ}C$
Power Dissipation $T_C = 75^{\circ}C$	$P_D$	25	W
Junction Temperature	$T_J$	+125	$^{\circ}C$
Storage Temperature	$T_{STG}$	-40 ~ +150	$^{\circ}C$

Note: 1. Absolute maximum ratings are those values beyond which the device could be permanently damaged.

Absolute maximum ratings are stress ratings only and functional device operation is not implied.

2. The device is guaranteed to meet performance specification within  $0^{\circ}C \sim 70^{\circ}C$  operating temperature range and assured by design from  $-40^{\circ}C \sim 85^{\circ}C$ .

### ■ THERMAL DATA

PARAMETER	SYMBOL	RATINGS	UNIT
Thermal Resistance junction-case	$\theta_{JC}$	3	$^{\circ}C/W$

### ■ ELECTRICAL CHARACTERISTICS

(Refer to the Test Circuit,  $V_S = \pm 18V$ ,  $T_a = 25^{\circ}C$ ,  $f = 1 kHz$ , unless otherwise specified.)

PARAMETER	SYMBOL	TEST CONDITIONS	MIN	TYP	MAX	UNIT
Supply Voltage	$V_S$		$\pm 4.5$		$\pm 25$	V
Quiescent Drain Current	$I_D$	$V_S = \pm 4.5V$ $V_S = \pm 25V$		18 21	50 90	mA
Input Bias Current	$I_B$	$V_S = \pm 22V$		0.4	0.5	$\mu A$
Input Offset Voltage	$V_{IN(OS)}$	$V_S = \pm 22V$			$\pm 15$	mV
Input Offset Current	$I_{IN(OS)}$	$V_S = \pm 22V$			$\pm 200$	nA
RMS Output Power	D = 0.5%	$P_O$ $R_L = 4\Omega$ $R_L = 8\Omega$ $R_L = 8\Omega, V_S = \pm 22V$	24	27		W
			22	18 25		
	D = 10%	$R_L = 4\Omega$ $R_L = 8\Omega$ $R_L = 8\Omega, V_S = \pm 22V$		35 22 32		
Music Power IEC268.3 RULES		D = 10%, T = 1s, $V_S = \pm 22.5V$ , $R_L = 4\Omega$		50		
Total Harmonic Distortion	THD	$R_L = 4\Omega$ f = 1kHz, $P_O = 0.1 \sim 24W$ f = 100Hz ~ 10kHz, $P_O = 0.1 \sim 18W$		0.03	0.5 0.5	%
		$R_L = 8\Omega, V_S = \pm 22V$ f = 1kHz, $P_O = 0.1 \sim 20W$ f = 100Hz ~ 10kHz, $P_O = 0.1 \sim 15W$		0.02	0.5	
Slew Rate	SR		5	8		V/ $\mu s$
Open Loop Voltage Gain	$G_V$			80		dB
Closed Loop Voltage Gain	$G_V$		30	30.5	31	dB
Power Bandwidth (-3dB)	$B_W$	$R_L = 4\Omega, V_{IN} = 200mV$	20 ~ 80000			Hz
Total Input Noise	$e_N$	Curve A B = 22Hz ~ 22kHz		4 5	10	$\mu V$
Input Resistance (pin 1)	$R_{IN}$		500			k $\Omega$
Supply Voltage Rejection	SVR	$R_S = 22K\Omega, f = 100Hz, V_{RIPPLE} = 0.5V_{rms}$		45		dB
Efficiency	$\eta$	$P_O = 28W, R_L = 4\Omega$		65		%
		$P_O = 25W, R_L = 8\Omega, V_S = \pm 22V$		67		

### ■ TYPICAL APPLICATION CIRCUIT

#### FOR SPLIT SUPPLY APPLICATION SUGGESTIONS

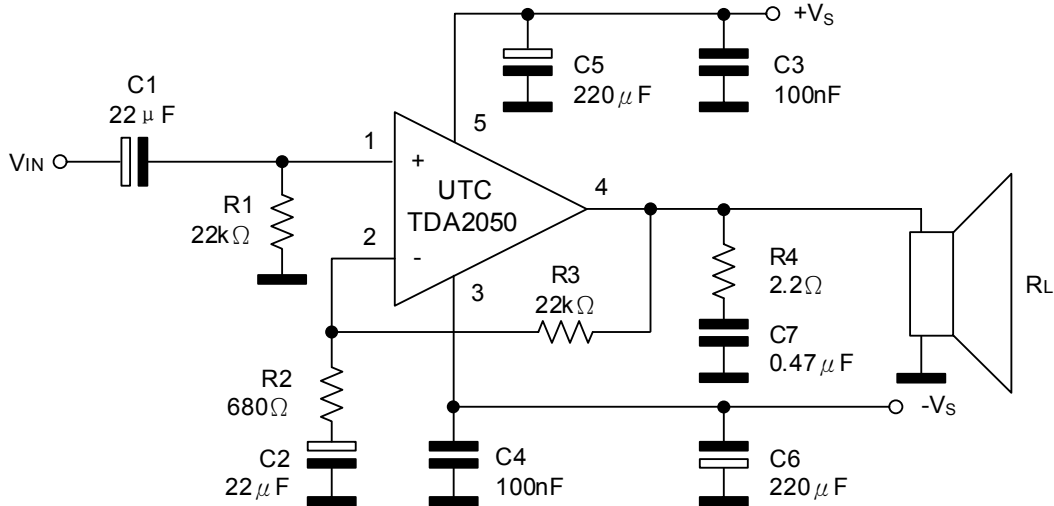

Figure.1 Split Supply Typical Application Circuit

The following table demonstrates the recommended values of the external components are those shown on above circuit. Different values can be used.

COMPONENT	PURPOSE	RECOMMENDED VALUE		
		TYPICAL	LARGER	SMALLER
R1	Input Impedance	22kΩ	Increase of Input Impedance	Decrease of Input Impedance
R2	Feedback Resistor	680Ω	Decrease of Gain*	Increase of Gain
R3		22kΩ	Increase of Gain	Decrease of Gain*
R4	Frequency Stability	2.2Ω	Danger of Oscillations	
C1	Input Decoupling DC	1µF		Higher Low-frequency cut-off
C2	Inverting Input DC Decoupling	22µF	Increase of Switch ON/OFF Noise	Higher Low-frequency cut-off
C3, C4	Supply Voltage Bypass	100nF		Danger of Oscillations
C5, C6	Supply Voltage Bypass	220µF		Danger of Oscillations
C7	Frequency Stability	0.47µF		Danger of Oscillations

\* The gain must be higher than 24dB

## ■ TYPICAL APPLICATION CIRCUIT(CONT.)

### FOR SINGLE SUPPLY APPLICATION SUGGESTIONS

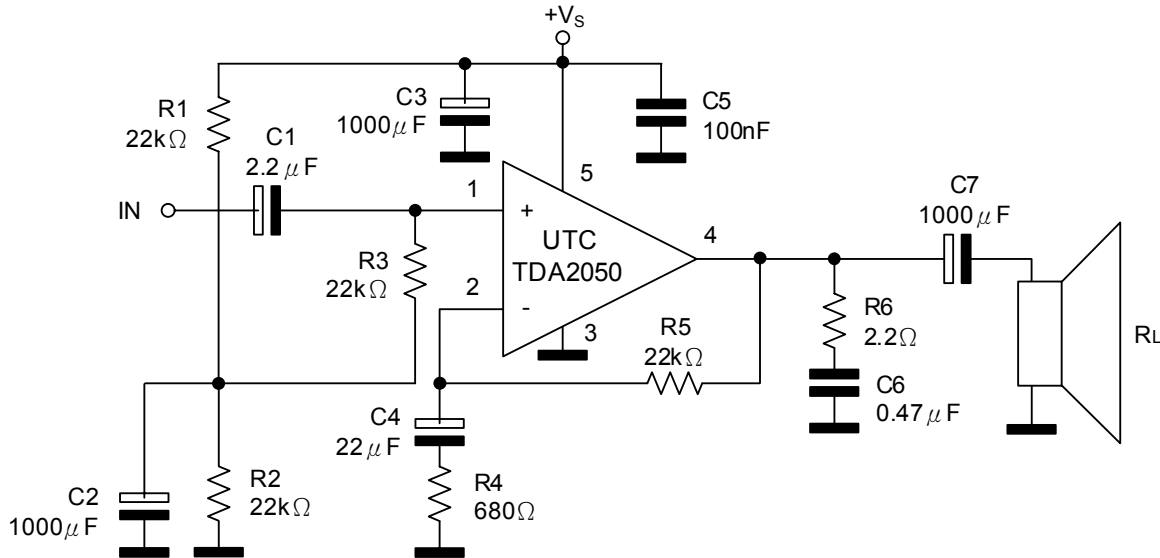

Figure.2 Single Supply Typical Application Circuit

The following table demonstrates the recommended values of the external components are those shown on above circuit. Different values can be used.

COMPONENT	PURPOSE	RECOMMENDED VALUE		
		TYPICAL	LARGER	SMALLER
R1, R2, R3	Biasing Resistor	22kΩ		
R4	Feedback Resistor	22kΩ	Increase of Gain	Decrease of Gain*
R5		680Ω	Decrease of Gain*	Increase of Gain
R6	Frequency Stability	2.2Ω	Danger of Oscillations	
C1	Input Decoupling DC	2.2μF		Higher Low-frequency cut-off
C2	Supply Voltage Rejection	100μF	Worse Turn-off Transient Worse Turn-on Delay	
C3	Supply Voltage Bypass	1000μF		Danger of Oscillations Worse of Turn-off Transient
C4	Inverting Input DC Decoupling	22μF	Increase of Switch ON/OFF	Higher Low-frequency cut-off
C5	Supply Voltage Bypass	100nF		Danger of Oscillations
C6	Frequency Stability	0.47μF		Danger of Oscillations
C7	Output DC Decoupling	1000μF		Higher Low-frequency cut-off

\* The gain must be higher than 24dB

**NOTE:** If the supply voltage is lower than 40V and the load is 8Ω (or more), a lower value of C2 (i.e. 22μF) can be used. C7 can be larger than 1000μF only if the supply voltage does not exceed 40V.

■ **TYPICAL CHARACTERISTICS** (Split Supply Test Circuit, unless otherwise specified)

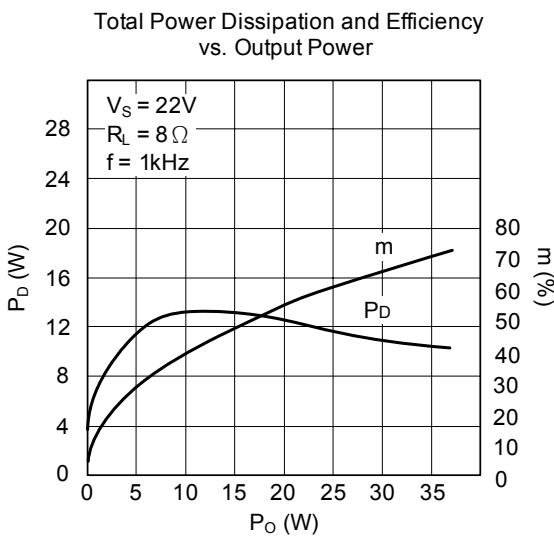
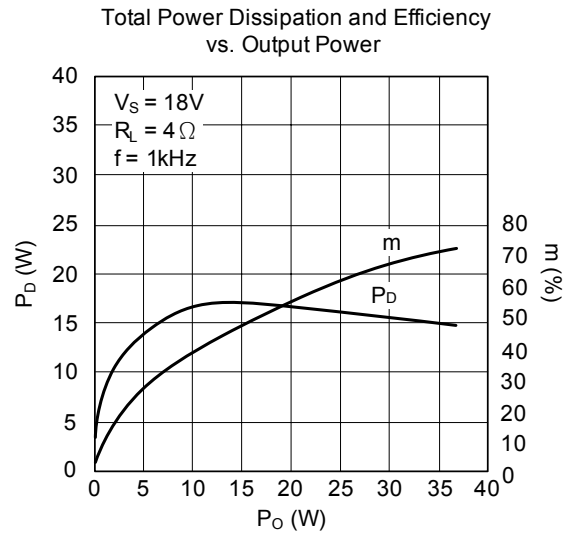
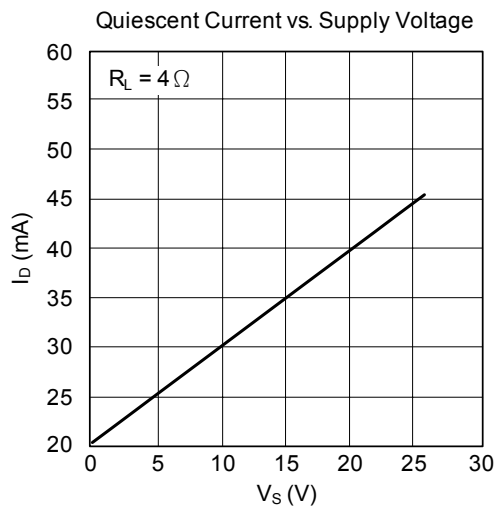
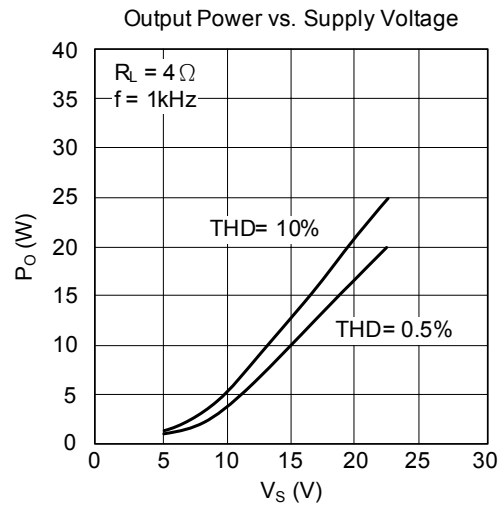
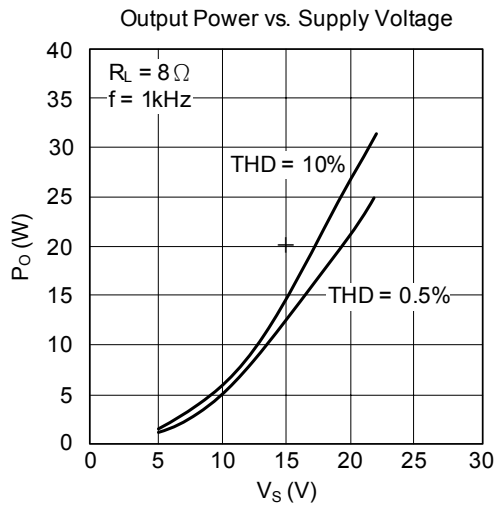

UTC assumes no responsibility for equipment failures that result from using products at values that exceed, even momentarily, rated values (such as maximum ratings, operating condition ranges, or other parameters) listed in products specifications of any and all UTC products described or contained herein. UTC products are not designed for use in life support appliances, devices or systems where malfunction of these products can be reasonably expected to result in personal injury. Reproduction in whole or in part is prohibited without the prior written consent of the copyright owner. The information presented in this document does not form part of any quotation or contract, is believed to be accurate and reliable and may be changed without notice.