

# Giant Magneto Resistive Position Sensor Version 2.0

## GMR B6

This angle sensor is based on the Giant Magneto Resistive (GMR) technology. It is outstanding for the huge tolerances it offers to the user in assembly.

### Features

- GMR sensor in SMD package
- **Sensitive to the direction**, not to the intensity of the magnetic field
- Constant  $T_C$  of basic resistance  $R$  and magneto resistance  $\Delta R$

### Applications

- Rotation and linear sensing with large airgaps
- Angle encoders
- Contactless potentiometers
- Incremental encoders

### Pin Configuration

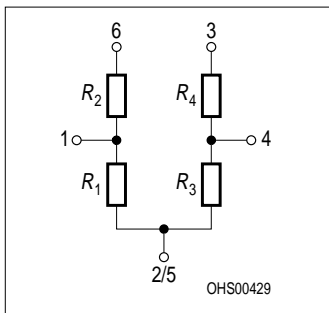

6, 3	supply
5 (= 2)	ground
1, 4	GMR bridge access

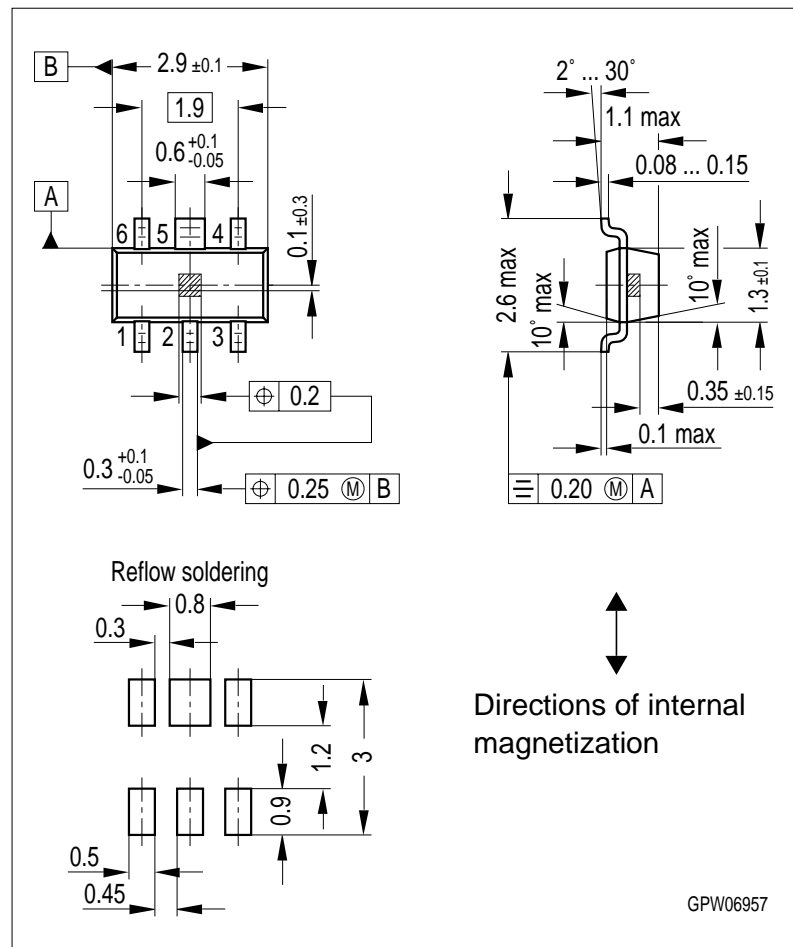

Dimensions in mm

GPW06957

Type	Marking	Ordering Code
GMR B6	B	Q62705-K5004

The GMR B6 is an angle sensor based on sputtered metallic multilayer technology. 4 resistors are monolithically integrated on 1 chip. They can be used as a fullbridge or, if 2 external resistors are added, as 2 halfbridges. The outstanding feature of this magnetic sensor is the fact, that it is sensitive to the orientation of the magnetic field and not to its intensity as long as the field is in a range between 5 ... 15 kA/m. This means, the signal output of this sensor is independent of the sensor position relative to the magnet in lateral, axial or rotational direction in the range of several millimeters. Optimum results are achieved by using magnetic targets like permanent magnets or magnetic pole-wheels. There is no need for a biasing magnet! Due to the linear change of both, basic and field dependent part of the resistance vs. temperature, simple and efficient electronic compensation of  $T_C (R, \Delta R)$  is possible.

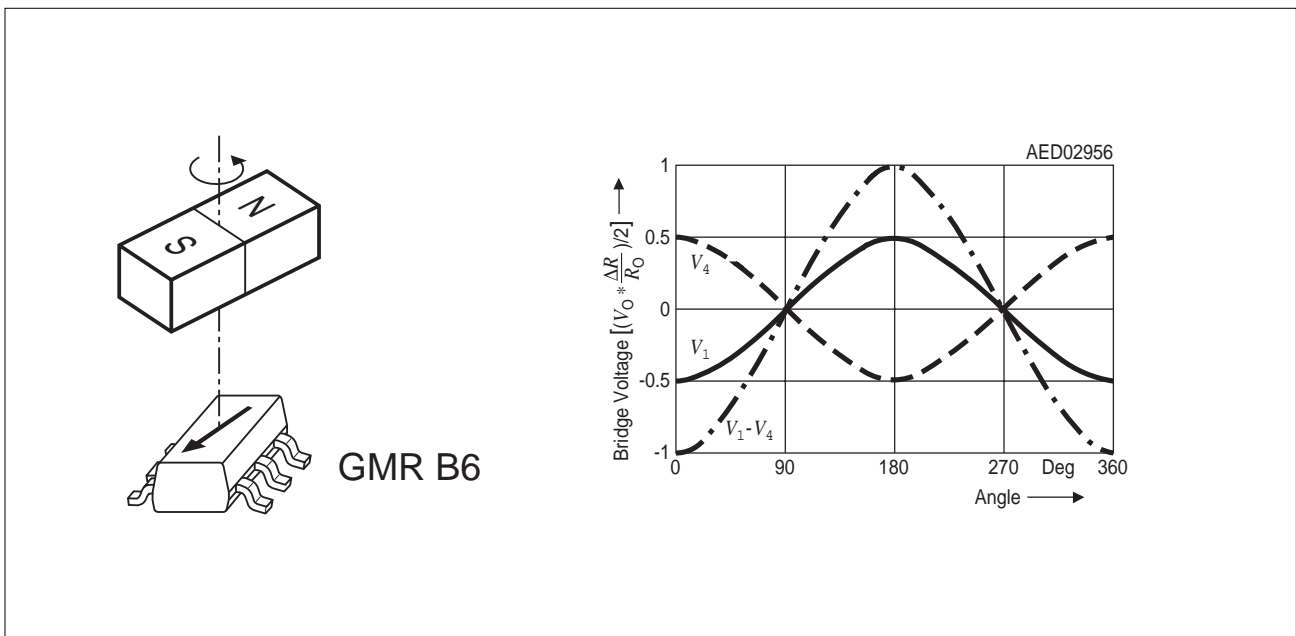

**Figure 1**  
**Output Voltage of Half Bridges ( $V_1$ ,  $V_4$ ) and Full Bridge ( $V_4 - V_1$ ) as a Function of the Magnetic Field Orientation**

**Maximum Ratings**

Parameter	Symbol	Value	Unit
Operating temperature	$T_A$	- 40 ... + 150	°C
Storage temperature	$T_{stg}$	- 50 ... + 150	°C
Supply voltage	$V_1$	7	V
Thermal conductivity	$G_{thC} A$	> 4	mW/K
Magnetic field <sup>1)</sup>	$H_{rot}$	< 15	kA/m

<sup>1)</sup> larger fields may reduce the magnetoresistive effect irreversibly

**Characteristics ( $T_A = 25\text{ °C}$ )**

Parameter	Symbol	Value	Unit
Nominal supply voltage	$V_{1N}$	5	V
Basic resistance	$R_0$	> 700	$\Omega$
Magnetoresistive effect $H_{rot} = 5 \dots 15\text{ kA/m}$	$\Delta R/R_0$	> 4	%
Output signal fullbridge @ $V_{1N} = 5\text{ V}$	$V_{OUT}$	> 200	mV
Offset voltage @ $V_{1N} = 5\text{ V}$	$ V_0 $	< 8	mV
Temperature coefficient of basic resistance	$TC_{R0}$	+ 0.09 ... + 0.12	%/K
Temperature coefficient of magnetoresistance	$TC_{\Delta R}$	- 0.12 ... - 0.09	%/K
Temperature coefficient of magnetoresistive effect	$TC_{\Delta R/R_0}$	- 0.27 ... - 0.23	%/K

**Application Hints**

The application mode of the GMR position sensor is preferably as a bridge or halfbridge circuit. In every case this type of circuit compensates for the  $T_C$  of the resistance value  $R_0$ . To compensate for the  $T_C$  of the GMR effect  $\Delta R/R_0$ , if there is the necessity, is left to the application circuit and can be done for example with a NIC circuit. When operated over a complete 360° turn, a total signal of  $\approx 20\text{ mV/V}$  is achieved at 25 °C with a halfbridge. The output signal is doubled to of  $\approx 40\text{ mV/V}$  when a fullbridge circuit is used. In the case of linear position sensing, the electrical circuit remains unchanged.

**Output Voltage Degradation (typical) at high Temperature Operation**

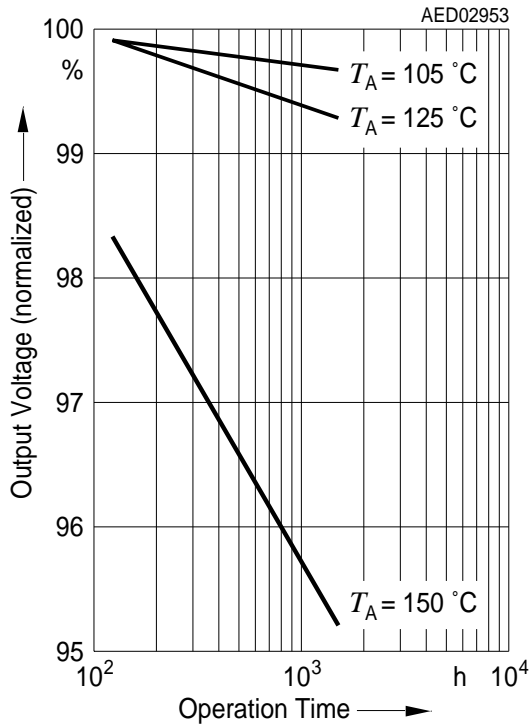

**Magnetoresistive Effect (typical) versus Temperature  $\Delta R/R_0 = f(T_A)$**

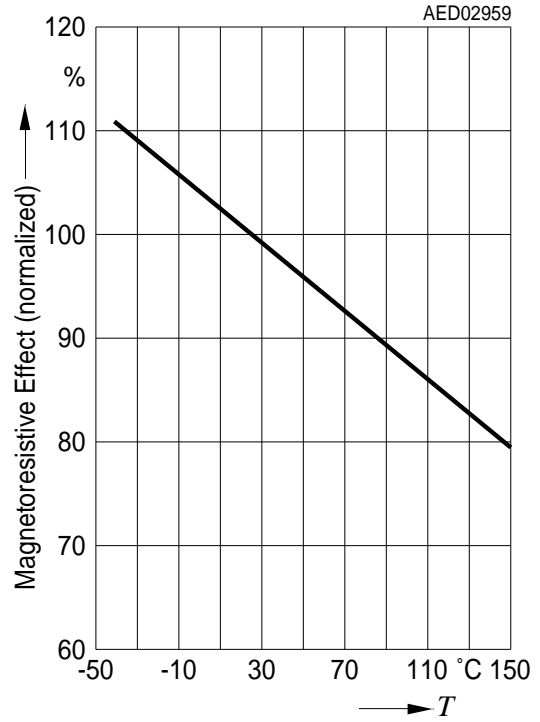

**Basic Resistance (typical) versus Temperature  $R_0 = f(T_A)$**

