



## DTA114T

### PNP SILICON TRANSISTOR

## DIGITAL TRANSISTORS (BUILT-IN BIAS RESISTORS)

### FEATURES

- \* Built-in bias resistors that implies easy ON/OFF applications.
- \* The bias resistors are thin-film resistors with complete isolation to allow positive input.

### EQUIVALENT CIRCUIT

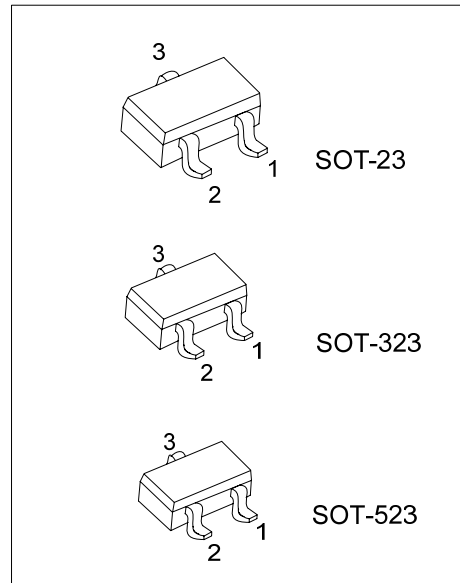
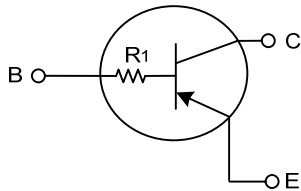

\*Pb-free plating product number:DTA114TL

### ORDERING INFORMATION

Order Number		Package	Pin Assignment			Packing
Normal	Lead Free Plating		1	2	3	
DTA114T-AE3-R	DTA114TL-AE3-R	SOT-23	E	B	C	Tape Reel
DTA114T-AL3-R	DTA114TL-AL3-R	SOT-323	E	B	C	Tape Reel
DTA114T-AN3-R	DTA114TL-AN3-R	SOT-523	E	B	C	Tape Reel

<p>DTA114TL-AE3-R</p> <p>(1) Packing Type (2) Package Type (3) Lead Plating</p>	<p>(1) R: Tape Reel (2) AE3: SOT-23, AL3: SOT-323, AN3: SOT-523 (3) L: Lead Free Plating, Blank: Pb/Sn</p>
---	--

### MARKING

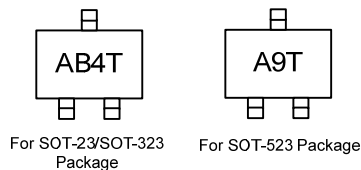

■ ABSOLUTE MAXIMUM RATINGS (Ta = 25°C)

PARAMETER		SYMBOL	RATING	UNIT
Collector-Base Voltage		$V_{CBO}$	-50	V
Collector-Emitter Voltage		$V_{CEO}$	-50	V
Emitter-Base Voltage		$V_{EBO}$	-5	V
Collector Current		$I_C$	-100	mA
Collector Power Dissipation	SOT-23	$P_C$	200	mW
	SOT-323/SOT-523		150	mW
Junction Temperature		$T_J$	+150	°C
Storage Temperature		$T_{STG}$	-55~+150	°C

Note Absolute maximum ratings are those values beyond which the device could be permanently damaged. Absolute maximum ratings are stress ratings only and functional device operation is not implied.

■ ELECTRICAL CHARACTERISTICS (Ta= 25°C, unless otherwise specified)

PARAMETER	SYMBOL	TEST CONDITIONS	MIN	TYP	MAX	UNIT
Collector-Base Breakdown Voltage	$BV_{CBO}$	$I_C = -50\mu A$	-50			V
Collector-Emitter Breakdown Voltage	$BV_{CEO}$	$I_C = -1mA$	-50			V
Emitter-Base Breakdown Voltage	$BV_{EBO}$	$I_E = -50\mu A$	-5			V
Collector-Emitter Saturation Voltage	$V_{CE(SAT)}$	$I_C = -10mA, I_B = -1mA$			-0.3	V
Collector Cutoff Current	$I_{CBO}$	$V_{CB} = -50V$			-0.5	$\mu A$
Emitter Cutoff Current	$I_{EBO}$	$V_{EB} = -4V$			-0.5	$\mu A$
DC Current Gain	$h_{FE}$	$V_{CE} = -5V, I_C = -1mA$	100	250	600	
Input Resistance	$R_1$		7	10	13	k $\Omega$
Transition Frequency	$f_T$	$V_{CE} = -10V, I_E = 5mA, f = 100MHz^*$		250		MHz

\* Transition frequency of the device

## ■ TYPICAL CHARACTERISTICS

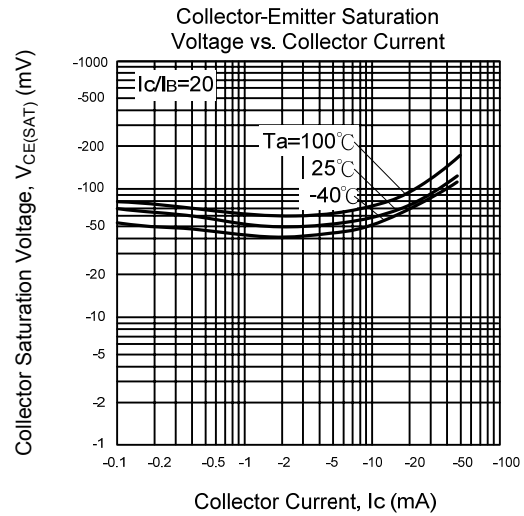
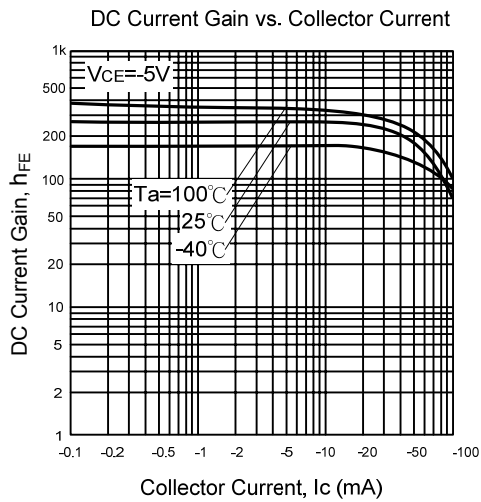

UTC assumes no responsibility for equipment failures that result from using products at values that exceed, even momentarily, rated values (such as maximum ratings, operating condition ranges, or other parameters) listed in products specifications of any and all UTC products described or contained herein. UTC products are not designed for use in life support appliances, devices or systems where malfunction of these products can be reasonably expected to result in personal injury. Reproduction in whole or in part is prohibited without the prior written consent of the copyright owner. The information presented in this document does not form part of any quotation or contract, is believed to be accurate and reliable and may be changed without notice.