

Features

- Operating voltage: 2.4V~5.2V
- Low power consumption and high noise immunity
- Built-in oscillator needs only 5% resistor
- Learning function
- Maximum of 8 sets of customer codes can be stored
- 2²⁴ information
- 3 local alarm trigger inputs: TRIG, AL+, AL-
- ACC can disarm whole car alarm system
- Easy interface with RF or IR medium
- Check received codes 3 times

Applications

- Burglar alarm system
- Smoke and fire alarm system
- Garage door controllers
- Car door controllers
- Car alarm system
- Security system
- Cordless telephones
- Other remote control systems

General Description

The HT6P12 is a 24-bit decoder with a learning function. It pairs with the HT6P20D encoder for remote control system applications.

The HT6P12 can interface with HOLTEK's EEPROM (HT93LC46). When the data pins of the HT6P20D (data negative polarity output type) encoder is triggered from a range of 2²⁴ series, a complete remote car alarm system is formed with the HT6P12. The decoder can store 8 sets of customer codes maximum at the learning mode. The first 20 bits of the received 24 bit of information are interpreted as a customer

code and the last 4 bits as control signal data. If the received 20 bits of customer code match the bits of one of the stored customer codes in the EEPROM after continuous checking three times, the remaining 4-bit data are latched and then the control function is executed.

The HT6P12 incorporates five types of output functions, namely arm/disarm, panic, find car, mute, and On/Off. It, in addition, provides a momentary data output for other user-defined special purposes.

Pin Assignment

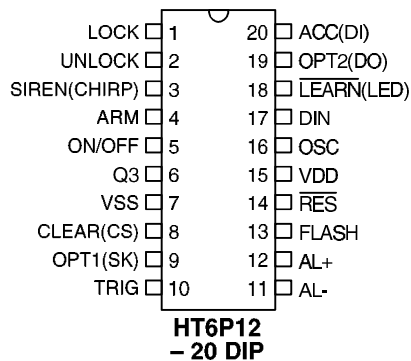

Block Diagram

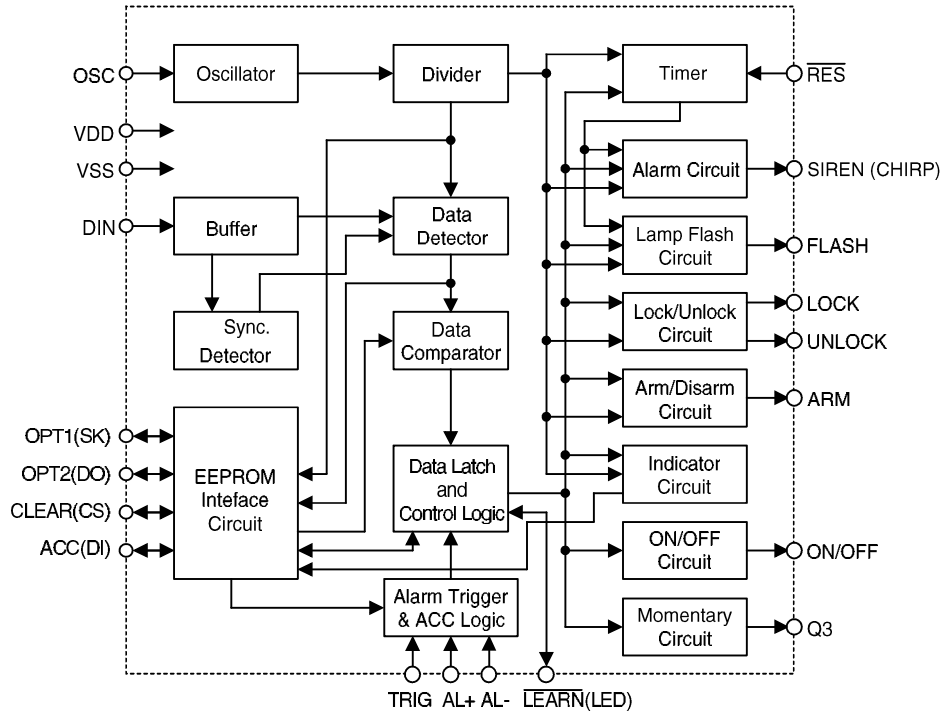

Pad Assignment

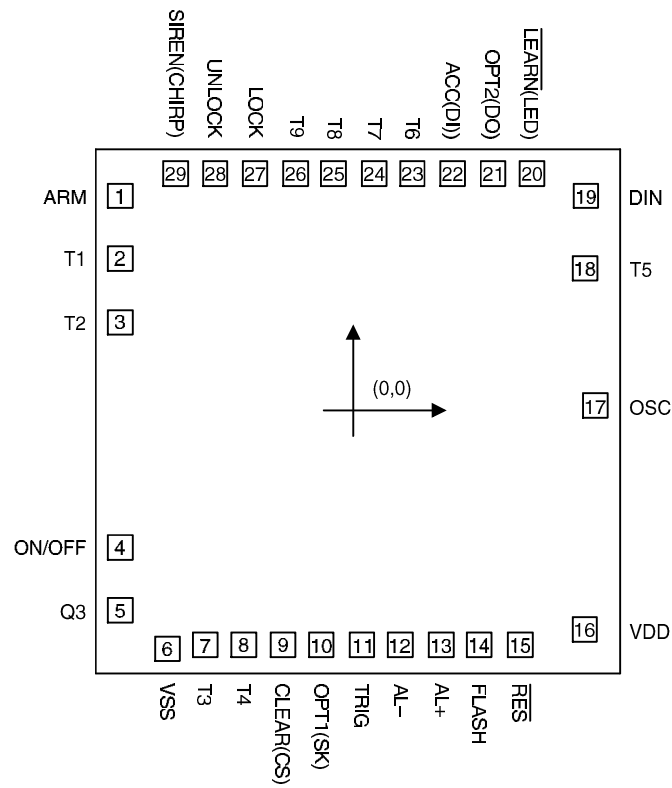

Chip size: 2580 × 2580 (μm)²

- * The IC substrate should be connected to VSS in the PCB layout artwork.
- * The T4 pad must be bonded to VDD or VSS.
- * Other test pad (T1~T3, T5~T9) must be floating.

Pad Coordinates

 Unit: μm

| Pad No. | X | Y | Pad No. | X | Y |
|---------|---------|---------|---------|--------|--------|
| 1 | -1113.4 | 936 | 16 | 1108.4 | -955.7 |
| 2 | -1113.4 | 662.8 | 17 | 1158.4 | 23 |
| 3 | -1113.4 | 384 | 18 | 1109 | 620.3 |
| 4 | -1113.4 | -598.5 | 19 | 1113.4 | 936.7 |
| 5 | -1113.4 | -871.5 | 20 | 855.6 | 1032.2 |
| 6 | -887.4 | -1039.7 | 21 | 668.2 | 1032.2 |
| 7 | -707.5 | -1022.2 | 22 | 476.3 | 1032.2 |
| 8 | -525 | -1022.2 | 23 | 284.2 | 1032.2 |
| 9 | -336.2 | -1022.2 | 24 | 101.7 | 1032.2 |
| 10 | -153.7 | -1022.2 | 25 | -95.1 | 1032.2 |
| 11 | 43.1 | -1022.2 | 26 | -277.6 | 1032.2 |
| 12 | 225.6 | -1022.2 | 27 | -469.7 | 1032.2 |
| 13 | 422.4 | -1022.2 | 28 | -661.6 | 1032.2 |
| 14 | 604.9 | -1022.2 | 29 | -849 | 1032.2 |
| 15 | 799.9 | -1022.2 | | | |

Pin Description

| Pin Name | I/O | Internal Connection | Description |
|---------------|-----|---------------------|--|
| LOCK | O | CMOS OUT | Lock signal output pin to control an external lock, active high |
| UNLOCK | O | CMOS OUT | Unlock signal output pin to control an external lock, active high |
| SIREN (CHIRP) | O | CMOS OUT | Siren or chirp signal output pin to control an external siren circuit, active high |
| ARM | O | CMOS OUT | Arm state output pin, toggle function, active high |
| ON/OFF | O | CMOS OUT | ON/OFF output pin for external control use, toggle function |
| Q3 | O | CMOS OUT | Momentary data output pin for external control use, active high |
| VSS | — | — | Negative power supply (GND) |
| CLEAR(CS) | I/O | CMOS I/O | Input: All data in the EEPROM are erased if the $\overline{\text{LEARN}}(\text{LED})$ pin turns low and the CLEAR(CS) pin turns high over 1 seconds, or if the CLEAR(CS) pin turns high for over 1 seconds in the learning state. Output: EEPROM chip selection signal output (connected to the CS pin of EEPROM) |

| Pin Name | I/O | Internal Connection | Description |
|---------------------------------------|-----|---------------------|--|
| OPT1(SK) | I/O | CMOS I/O Pull-High | Input: Selection of the siren and chirp sound function: Hi or Open: Chirp and siren sounds enabled Low: Chirp and siren sounds disabled Output: Serial clock output for EEPROM (connected to the SK pin of EEPROM) |
| TRIG | I | CMOS IN | Alarm trigger input pin in the arm state, high active |
| AL- | I | CMOS IN | Alarm trigger input pin in the arm state, low active |
| AL+ | I | CMOS IN | Alarm trigger input pin in the arm state, high active |
| FLASH | O | CMOS OUT | Flash output pin to control an external car lamp circuit |
| $\overline{\text{RES}}$ | I | CMOS IN | Input pin for resetting the chip inside, low active |
| VDD | — | — | Positive power supply |
| OSC | I | — | Oscillator input pin |
| DIN | I | CMOS IN | Serial data input pin |
| $\overline{\text{LEARN}}(\text{LED})$ | I/O | CMOS I/O Pull-High | Input: To set the chip into the learning state or to erase all EEPROM data when used with the CLEAR(CS) pin, low active Output: To sink the LED current for indicating the function state |
| OPT2(DO) | I/O | CMOS I/O Pull-High | Input: Selection of the car lamp flash function during alarm Hi or Open: Lamp flash enabled Low: Lamp flash disabled Output: To activate the LED for indicating the function state (refer to the function description) This pin is also used to output the received data to the EEPROM (connected to the DI pin of EEPROM) |
| ACC(DI) | I | CMOS IN | An active high signal to the ACC pin can disarm the alarm system. This pin is also used to input data from the EEPROM (connected to the DO pin of EEPROM) |

Approximate internal connection circuits

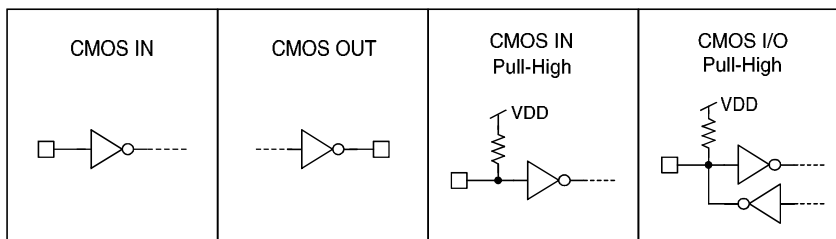

Absolute Maximum Ratings*

| | | | |
|----------------------|--|----------------------------|----------------|
| Supply Voltage | -0.3V to 5.5V | Storage Temperature..... | -50°C to 125°C |
| Input voltage..... | V _{SS} -0.3V to V _{DD} +0.3V | Operating Temperature..... | -20°C to 75°C |

*Note: Stresses above those listed under “Absolute Maximum Ratings” may cause permanent damage to the device. These are stress ratings only. Functional operation of this device at these or any other conditions above those indicated in the operational sections of this specification is not implied and exposure to absolute maximum rating conditions for extended periods may affect device reliability.

Electrical Characteristics

(Ta=25°C)

| Symbol | Parameter | Test Conditions | | Min. | Typ. | Max. | Unit |
|------------------|-----------------------------------|-----------------|-----------------------------------|------|------|-----------------|------|
| | | V _{DD} | Conditions | | | | |
| V _{DD} | Operating Voltage | — | — | 2.4 | 5 | 5.2 | V |
| I _{DD} | Operating Current | 5V | No load F _{OSC} =2MHz | — | 1 | 2 | mA |
| I _{OH1} | Output Source Current | 5V | V _{OH1} =4.5V | -2 | -3 | — | mA |
| I _{OL1} | Output Sink Current | 5V | V _{OL1} =0.5V | 4 | 6 | — | mA |
| V _{IH} | “H” Input Voltage | 5V | — | 3.5 | — | V _{DD} | V |
| V _{IL} | “L” Input Voltage | 5V | — | 0 | — | 1 | V |
| R _{PH} | Pull-High Resistance | 5V | V _{IN} =0V | 10 | 30 | 50 | kΩ |
| T _{KEY} | LEARN and CLEAR Key Debounce Time | — | F _{OSC} =2MHz | — | 20 | — | ms |
| F _{OSC} | Oscillator Frequency | 5V | R _{OSC} =200kΩ | — | 2 | — | MHz |

Functional Description

The HT6P12 is a 24-bit decoder with a learning function. It pairs with the HT6P20D (data negative polarity output type) encoder for remote control system applications. The decoder can interface with HOLTEK’s EEPROM

(HT93LC46). It stores a maximum of 8 sets of customer codes in the EEPROM, and contains an option table which is written into the EEPROM through HOLTEK’s tool.

Option table

| Option Items | Range | Default Values |
|------------------------------|---|----------------|
| Arm→Disarm Chirp Sound Times | 1~4 times | 2 times |
| Disarm→Arm Chirp Sound Times | 1~4 times | 1 time |
| Output Type Option | A, B, C (See the section “Output function selection”) | A |

| Option Items | Range | Default Values |
|---|---|-----------------------------------|
| Arm→Disarm, Disarm→Arm and FIND_CAR Chirp Output Period | OFF time: (1~31)×40ms ON time: (1~7)×40ms | OFF time: 240ms ON time: 80ms |
| | or Function Disabled | |
| Entry Delay Time | 1~255 secs | 5 secs |
| | or Function Disable | |
| AL_TRIG Siren Active Time | 1~255 secs | 10 secs |
| | or Function Disable | |
| TRIG And Panic Siren Active Time, One Interval | 1~255 secs | 20 secs |
| | or Function Disable | |
| TRIG Siren Pause Time | 1~127 secs | 10 secs |
| In Mute Mode, Disarm→Arm Chirp Sound | Enabled or Disabled | Enabled |
| AUTO_ARM Delay Time | (1~15)× 4 secs | Disabled |
| | or AUTO_ARM Disabled | |
| Max. Amount of TRIG Siren Active Cycle | 1~14 or unlimited or disable | Unlimited |
| RE_ARM Delay Time | 1~255 secs | 20 secs |
| | or RE_ARM Disabled | |
| Arm→Disarm, Disarm→Arm Lamp Flash Period | OFF time: (1~15)×100ms ON time: (1~15)×100ms | OFF time: 600ms ON time: 600ms |
| | or Function Disabled | |
| Arm→Disarm Lamp Flash Times | 1~15 times | 2 times |
| Disarm→Arm Lamp Flash Times | 1~15 times | 1 time |
| Alarm,Panic And FIND_CAR States Lamp Flash Period | OFF time: (1~15)×100ms ON time: (1~15)×100ms | OFF time: 300ms ON time: 200ms |
| | or Function Disabled | |
| Arm State LED Flash Period | OFF time: (1~15)×100ms ON time: (1~15)×100ms | OFF time: 800ms ON time: 200ms |
| | or Function Disabled | |
| Alarm State LED Flash Period | OFF time: (1~15)×100ms ON time: (1~15)×100ms | OFF time: 300ms On time: 100ms |
| | or Function Disabled | |
| LOCK Time | (1~255)×100ms | 2 secs |
| | or LOCK Disabled | |
| UNLOCK Time | (1~255)×100ms | 2 secs |
| | or UNLOCK Disabled | |
| FIND_TIME | 1~255 secs | 3 secs |
| | or FIND_CAR Disabled | |

Power on initial

After power is supplied, the HT6P12 reads in a value of an option parameter from the EEPROM to decide the operation type as well as the output format. If the option table is empty or the option format is erroneous, the HT6P12 will automatically load the internal default value to replace the value of the option table. The FLASH pin and the LED will also output a flash signal warning. After the operation type and the output format are both set, the decoder will check the customer code in the EEPROM. If a customer code has been stored, the HT6P12 will enter the idle state and go to the arm state immediately. But if none of the customer codes has been stored in the EEPROM, the decoder will enter the waiting state and the external LED will turn on (see the application circuits) to indicate a waiting state.

Waiting state

The HT6P12 enters the waiting mode after power is turned on and none of the customer codes has been saved in the EEPROM. In the waiting state, the oscillator is activated, and the HT6P12 is ready for receiving trigger signals from the $\overline{\text{LEARN}}(\text{LED})$ pin. After the trigger signals have been received from the $\overline{\text{LEARN}}(\text{LED})$ pin, the decoder will go to the learning state.

On the other hand, if trigger signals has not been received from the $\overline{\text{LEARN}}(\text{LED})$ pin, the decoder will go to the arm state after AUTO_ARM delay time. But, if the AUTO_ARM function is disabled (i.e., the AUTO_ARM delay time is zero, defined in the option table), the decoder will stay on the waiting state till trigger signals been received from the $\overline{\text{LEARN}}(\text{LED})$ pin.

Idle state

The HT6P12 enters the idle state after the EEPROM has stored one or more sets of customer codes in it. In the idle state, the HT6P12 is ready for receiving data from its paired encoder (HT6P20D) so as to trigger the DIN pin. Or pressing the LEARN key enters the learning state. Data in the EEPROM can be erased by

simultaneously pressing the LEARN and CLEAR keys over 1 seconds (refer to the application circuits).

Learning state

The HT6P12 enters the learning state from the waiting or from the idle state if the $\overline{\text{LEARN}}(\text{LED})$ pin is active low over 1 seconds. Then the LED output a flash signal at 1Hz rate until a set of customer codes has been acquired within 10 seconds (see the application circuits).

During the 10 seconds, if the DIN pin has received proper formatted data and no mistakes have been made after 5 times continuous check, the received customer code is stored in the EEPROM and the LED pin stops flashing also. After a customer code has been acquired, the learning state is terminated and the system goes to the idle state.

In contrast, during the 10 seconds if no proper formatted data has been entered, the LED pin will stop flashing and the decoder will return to its original state right after the time is up. The HT6P12 can save a maximum of 8 sets of customer codes in the EEPROM. Once the EEPROM has stored 8 sets of customer codes in it, the decoder cannot enter the learning state unless the customer codes in the EEPROM are all erased. In the learning state, all the output pins are held low.

EEPROM erase function

When the $\overline{\text{LEARN}}(\text{LED})$ pin turns low and the CLEAR(CS) pin turns high over 1 second all data in the EEPROM are erased. Once the CLEAR and LEARN keys are released the LED will automatically turn on.

Remote control mode

In the idle state, if the HT6P12 has received data from one of its paired encoders (HT6P20D), it compares the received customer code with one of the customer codes stored in the EEPROM three times continuously. If the received customer code matches one of the local customer codes in the EEPROM after a three times continuous check, the last 4 bits of the

received 24 bits of customer code are interpreted as control signals.

Output function selection

When the last 4 bits (bits 21~24) of the received 24 bits of customer code are interpreted as 4 kinds of control signal outputs, each control signal output controls an output function. There are totally 8 kinds of output functions, i.e., ARM/ DISARM, PANIC, ON/OFF, Q3, ARM, DISARM, MUTE, and FIND_CAR, which are further classified into three types A, B, and C. Each type consists of 4 different output functions. The mapping of the last 4 bits to the 4 kinds of output functions is as shown.

The output type is defined by the option table.

| Bit No. Output Type | 21 | 22 | 23 | 24 |
|------------------------|------------|--------|--------|----------|
| A | ARM/DISARM | PANIC | ON/OFF | Q3 |
| B | ARM | DISARM | MUTE | FIND_CAR |
| C | ARM/DISARM | PANIC | MUTE | FIND_CAR |

Arm/Disarm control

If the arm and disarm control signals are set on the same data bit (Output Type A or C), the arm and disarm states are toggle-controlled by the

same key of the encoder. But, if the arm and disarm control signals are set as 2 different data bits (Output Type B), the arm and disarm states are separately controlled.

After the disarm control signal has been received, and the LSI is in the arm state, the car lamp will flash twice successively (defined by the “Arm→Disarm lamp flash times” in the option table), the chirp sound will be output twice continuously (defined by the “Arm→Disarm chirp sound times” in the option table), the UNLOCK pin will be active high, a duration (defined by the “UNLOCK Time” in the option table), the ARM pin will be active low, and the alarm system will enter the disarm state. On the other hand, after the arm control signal has been received, the car lamp will flash once (defined by the “Disarm→Arm lamp flash times” in the option table), the LED will flash at 1Hz rate continuously (defined by the “Arm state LED flash period”), the chirp sound will be output once (defined by the “Disarm→Arm chirp sound times” in the option table), the LOCK pin will be active high, a duration (defined by the “LOCK Time” in the option table), the ARM pin will be active high, and the alarm system will enter the arm state. In addition, the duty of the chirp sound and lamp flash are both settable in the option table.

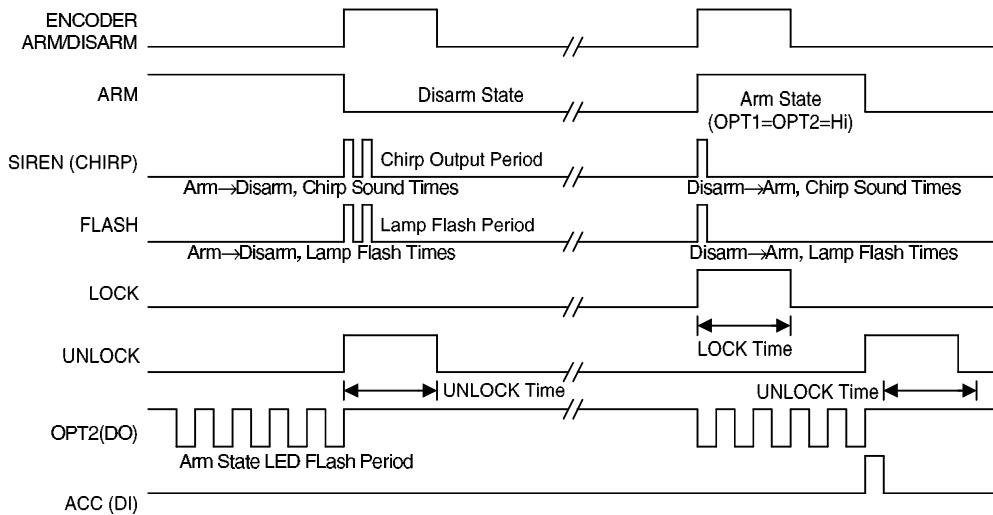

Fig.1 Arm/Disarm Timing

In the disarm state, if the RE_ARM is enabled (when the RE_ARM delay time is not zero; refer to the option table for details), the disarm state will change to the arm state after the RE_ARM delay time. The timing of the arm/disarm control is shown in the previous page.

Mute mode

If one of the encoder's data bits is set as a MUTE control bit (Output Type B or C), its function is similar to the function of the arm/disarm control except that the chirp sound is disabled in the mute mode (when the arm state changes to the disarm state). In the mute mode when the FIND_CAR function or the alarm trigger is activated, the chirp sound will be disabled. That is to say, only the car lamp will flash in the FIND_CAR mode or the alarm trigger mode under the MUTE function. When the disarm state changes to the arm state, the chirp sound can be enabled or disabled (defined by the "In mute mode, Disarm→Arm chirp Sound" in the option table).

Alarm trigger mode (AL+, AL-, TRIG)

With an alarm in the arm state, any one of the three signals AL+, AL-, and TRIG can trigger the alarm as described below.

- TRIG trigger

For the TRIG trigger, the LSI provides the following outputs:

- The FLASH pin will output a flash signal at a settable rate (defined by the "Alarm, Panic and FIND_CAR states lamp flash period" in the option table).
- The SIREN (CHIRP) pin will output a siren sound. The active interval is settable (defined by the "TRIG and Panic siren active time" and the "TRIG siren pause time" in the option table). Four intervals combined to produce a cycle.
- The LED will output a flash signal. The flash rate is settable (defined by the "Alarm state LED flash period" in the option table). The LED flash output will continue until ACC(DI) pin is activated.

If the TRIG trigger is removed within a cycle

of 4 intervals, the FLASH and SIREN outputs will stop at the end of a cycle. Otherwise they will continue to complete another cycle of 4 intervals. The total amount of cycle to be repeated can be set from 0 to 14 or unlimited (defined by the "maximum amount of TRIG SIREN active cycle" in the option table). After the repeating times have been set, the FLASH and SIREN output will stop at the end of the assigned cycle although the trigger signal is still not removed. Once the ACC (DI) pin is activated the three kinds of output will cease.

- AL+, AL- triggers

For the AL+ and AL- triggers, the AL+ is activated at a high level and the AL- at a low level. The LSI provides the following outputs:

- The FLASH pin will output a flash signal at a settable rate (defined by the "ALARM, Panic and FIND_CAR states lamp flash period" in the option table).
- The SIREN (CHIRP) pin will output a siren sound. The active interval is settable (defined by the "AL_TRIG siren active time" in the option table).
- The LED pin will output a flash signal. The flash rate is settable (defined by the "Alarm state LED flash period" in the option table). The LED flash output will continue until ACC(DI) pin is activated.

If the AL+ or AL- trigger signal is removed within the AL_TRIG siren active time (defined by the "AL_TRIG siren active time" in the option table), the FLASH and SIREN outputs will stop at the end of the active time. Otherwise, the system will remain at the alarm state, the AL_TRIG siren active time will be re-loaded to count, and the FLASH and SIREN outputs will continue until the signal is removed within new active time or the ACC (DI) is activated. Once the ACC (DI) pin is activated the three kinds of pin output will stop.

The TRIG, AL+, and AL- triggers are all disabled in the disarm state. Once the active high ACC(DI) input is activated, all the outputs will cease and the arm state will change to the disarm state. When the ACC(DI) pin return to low, if the AUTO_ARM is enabled

(when the AUTO_ARM delay time is not zero), the disarm state will change to the arm state after the AUTO_ARM delay time (defined by the "AUTO_ARM delay time" in the option table). The timing of the alarm trigger is shown below.

will sound and the car lamp will flash. The timing of the SIREN, FLASH, and LED outputs is the same as the timing of the alarm trigger mode. The active output length is on a par with the TRIG siren active time, One interval (defined by the "TRIG and Panic siren active time" in the option table). The siren sound as well as the car lamp flash can be interrupted by occurrence of a second panic control signal or by activating the ACC (DI) pin. The panic mode takes a priority of other modes.

Panic mode

Whether in the arm or disarm state, after a panic control signal has been received, the siren

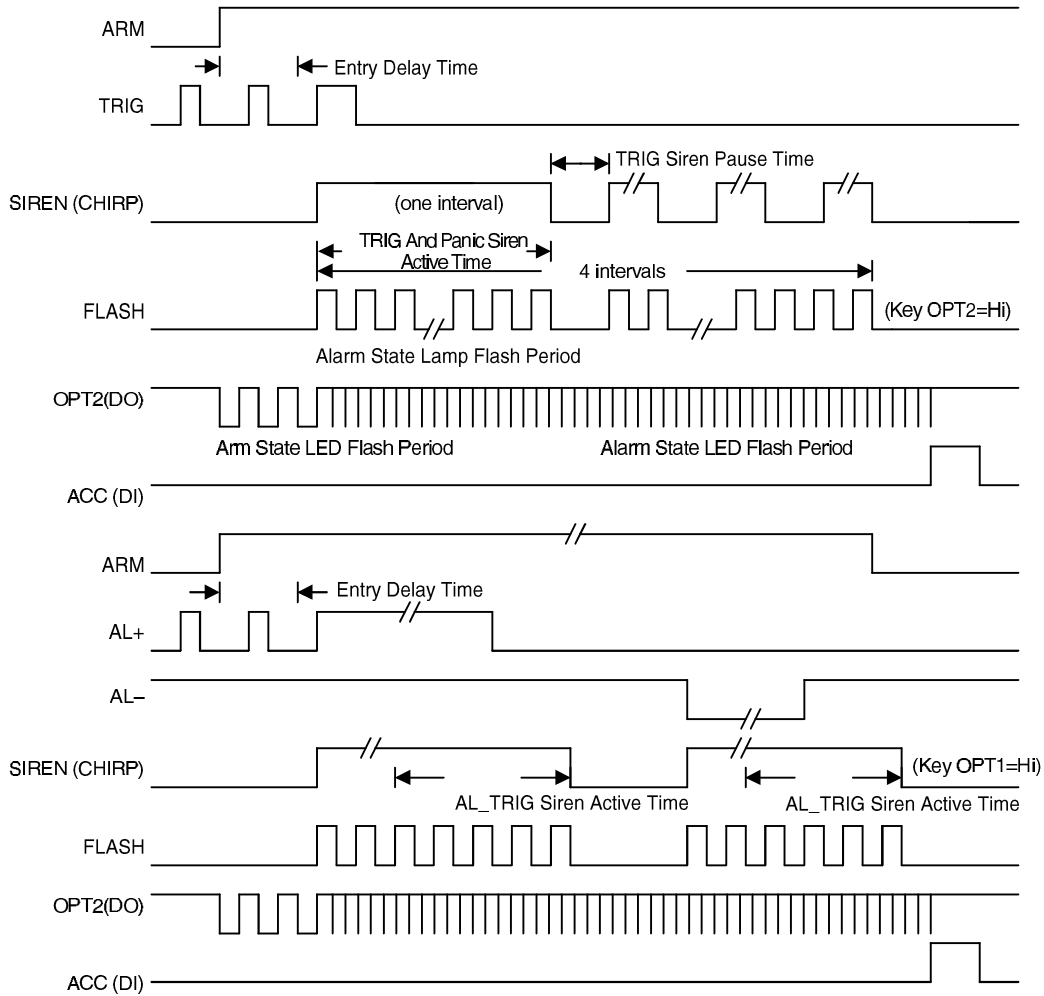

Alarm Triggers (AL+, AL-, TRIG) for Arm State

Note: During the Entry delay time, the chip ignores all trigger signals from the TRIG, AL+, AL- pins.

Once the Panic siren ends, the system will detect the state of the ACC (DI) pin.

If the ACC (DI) pin keeps at the Lo-level, the system will automatically execute the Disarm→Arm control once and the LED flash output will continue. Once the ACC(DI) pin detects a state transformation from Lo to Hi, the LED will turn off. The timing is shown below.

On the other hand, if the ACC (DI) keeps at the Hi-level, the LED flash output will continue. Once the ACC (DI) detects a state transformation from Lo to Hi, the LED will turn off. The timing is show below.

Find car mode

The HT6P12 enters the FIND_CAR mode when

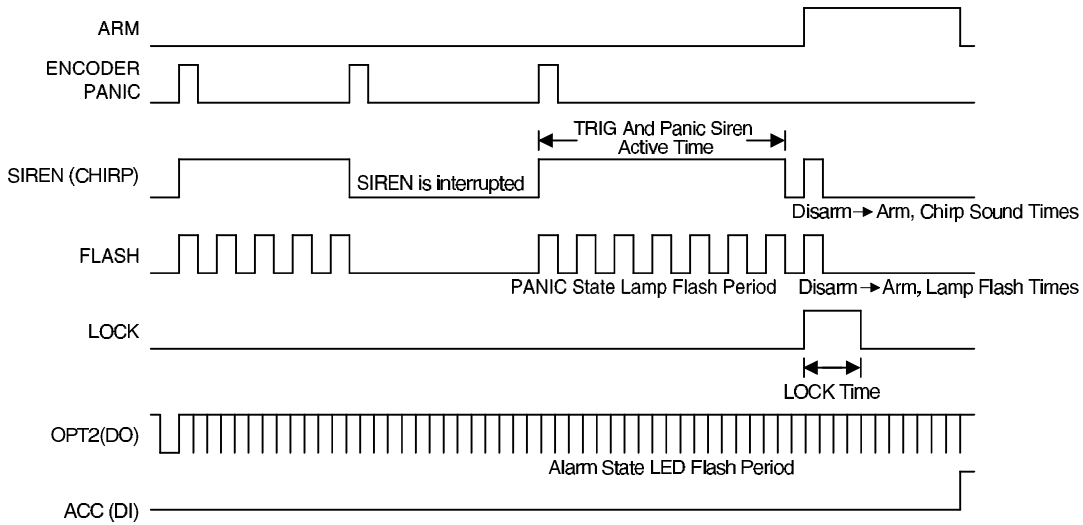

Panic Timing

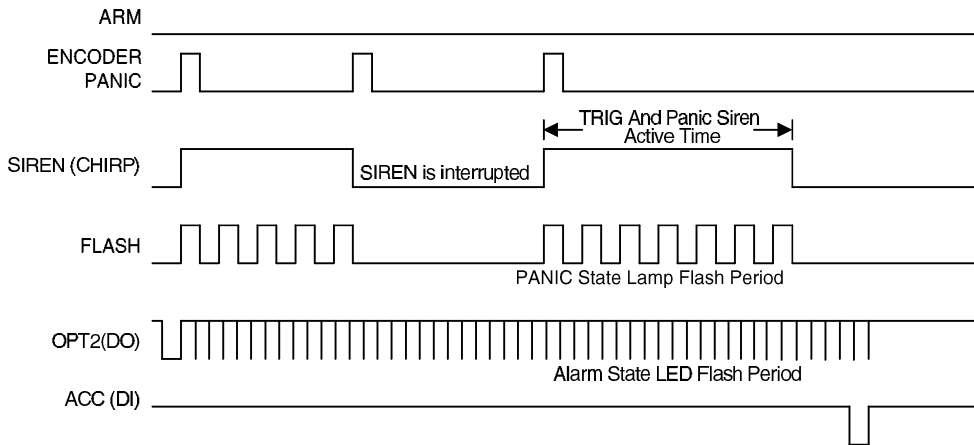

Panic Timing

one of the encoder's data bits is set as a FIND_CAR control signal (Output Type B or C). Whether in the arm or disarm state, as long as a FIND_CAR control signal has been received from the DIN pin, the car lamp will flash and the chirp will sound. The flash rate is identical to those in the alarm trigger mode. The chirp rate is defined by the "FIND CAR chirp output period" in the option table. If the control signal has been removed within the FIND_TIME (defined by the "FIND_TIME" in the option table), the car lamp flashing and the chirp output will stop at the end of the FIND_TIME. Otherwise they will continue to complete another new FIND_TIME period. If the encoder's FIND_CAR key is retriggered at this time the FIND_TIME will be re-counted. But, if the FIND_CAR key is triggered in the mute mode, the chirp function will be disabled. The timing of the FIND_CAR mode is shown below.

Door Open Alarm

If the TRIG pin is triggered and trigger signal is held in the disarm state, the SIREN will not be activated, and then the disarm state changes to the arm state. HT6P12 will be active for a

period of AL_TRIG siren active time, and the system will enter the alarm trigger mode, and the output of the SIREN, FLASH and LED is the same as the timing of the alarm trigger mode. To disable the output, the trigger signal on the TRIG pin has to be removed or the ACC(DI) pin be activated. The timing of the door open is shown below.

Alarm output (SIREN)

If the TRIG signal has been removed within a cycle of four intervals, the siren will stop at the end of the period. On the other hand, if the AL+ (AL-) signal has been removed within the period of the AL_TRIG siren active time, the siren will also cease at the end of the period. Otherwise it will continue to complete another new period.

The duration time of a cycle is decided by the value of the option table. The alarm state is terminated by the disarm control signal. After the panic control signal has been received, the SIREN (CHIRP) will output a period of time the same as the TRIG siren active time. The alarm state can be terminated by an active high ACC signal.

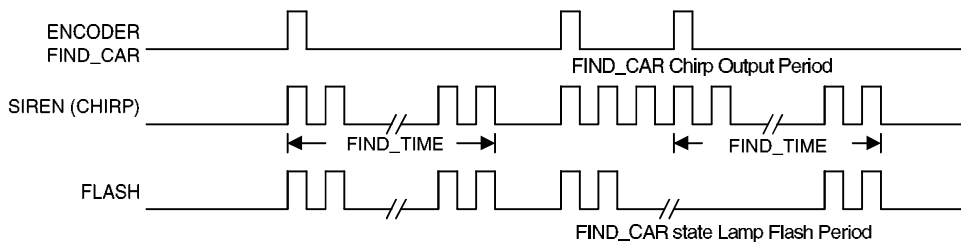

Find Car Timing

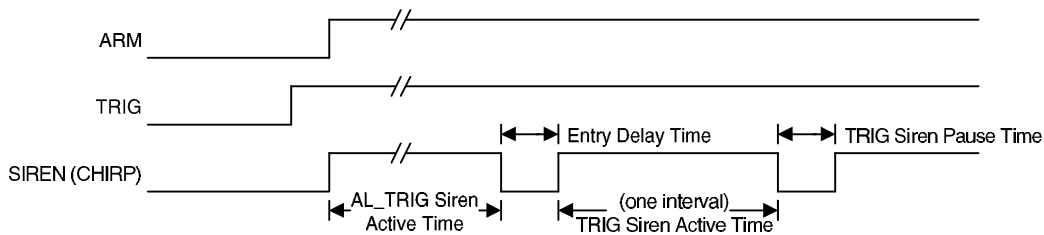

Door Open Alarm

When the SIREN enters the arm or disarm state, it will output some pulses (defined by the “Arm→Disarm chirp sound times” and the “Disarm→Arm chirp sound times” in the option table). The pulse width along with the pulse space is decided by the option table. Except in the panic trigger mode, the SIREN output can be inhibited by setting the OPT1(SK) pin to be in a low level before power is turned on (see the application circuits).

LOCK/UNLOCK output

The LOCK and UNLOCK pins are not activated at the initial power on. After the decoder enters the arm state the LOCK pin will output a 2-second pulse (by default). The UNLOCK pin, on the other hand, will output a 2-second pulse (by default) when the decoder enters the disarm state. The two pins cannot operate simultaneously. The LOCK pin takes a priority of the UNLOCK pin. During the LOCK or UNLOCK period, any control or trigger signals such as the ARM, DISARM, MUTE, ACC, TRIG, etc., are all disabled.

The UNLOCK pin will output a 2-second pulse each time the ACC (DI) pin receives a Hi to Lo signal. The timing is shown in Fig.1.

FLASH output

The FLASH pin will output under the following conditions:

- The LSI changes from the arm state to the disarm state or from the disarm state to the arm state. The flash rate is defined by the “Arm→Disarm, Disarm→Arm lamp flash period” in the option table.
- The LSI is in the alarm state. The flash rate is defined by the “ALARM, Panic and FIND_CAR states lamp flash period” in the option table.
- The LSI has received a PANIC trigger signal. The flash rate is defined by the “ALARM, Panic and FIND_CAR states lamp flash period” in the option table.
- The LSI has received a FIND_CAR trigger signal. The flash rate is defined by the

“ALARM, Panic and FIND_CAR states lamp flash period” in the option table.

This function can be inhibited by setting the OPT2(DO) pin key to be in a low level before power is turned on. (see the application circuits)

ACC input

Once the active high ACC (DI) input is activated, the car alarm system enters the disarm state, and the arm/disarm, mute, and FIND_CAR control signals as well as the TRIG, AL+, and AL-trigger signals all fail to be received. The PANIC, LOCK/UNLOCK, Q3, ON/OFF, CLEAR, LEARN, etc., control signals are still effective. But only the external LED stops flashing.

ARM output

When the HT6P12 operates in the arm state the ARM pin outputs a “Hi” signal; otherwise it outputs a “Lo” signal.

ON/OFF output

The LSI provides an external on/off toggle control when one of the data bits is set as an ON/OFF control signal (Output Type A). The ON/OFF timing is shown below.

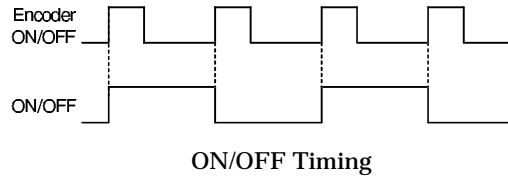

Q3 data output

Q3 is a momentary type of data output when one of the data bits is set as Q3 (Output Type A). This line is user-defined. The timing is shown below.

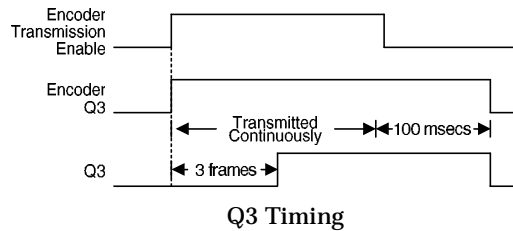

Power-on initial flowchart

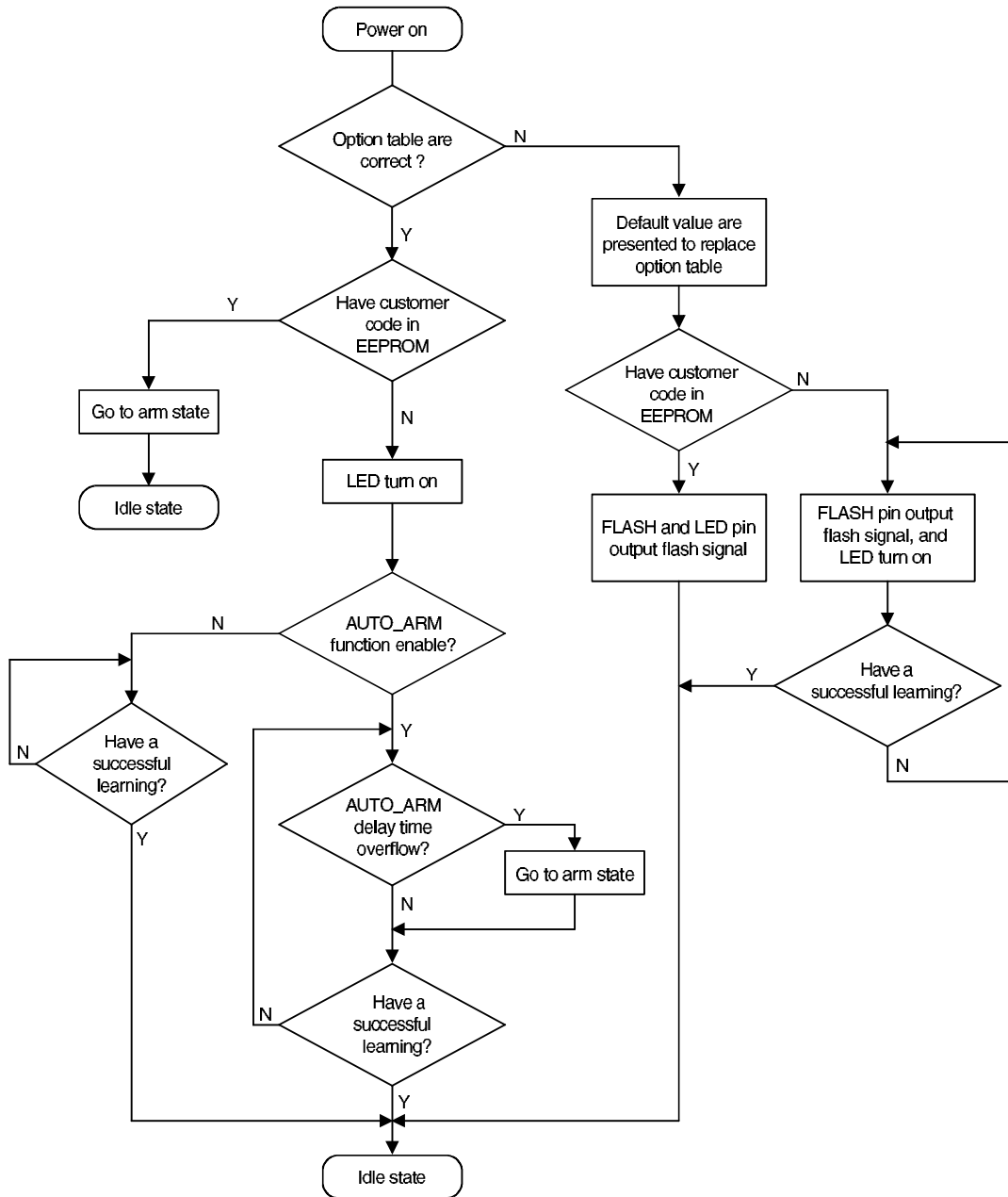

Idle state flowchart

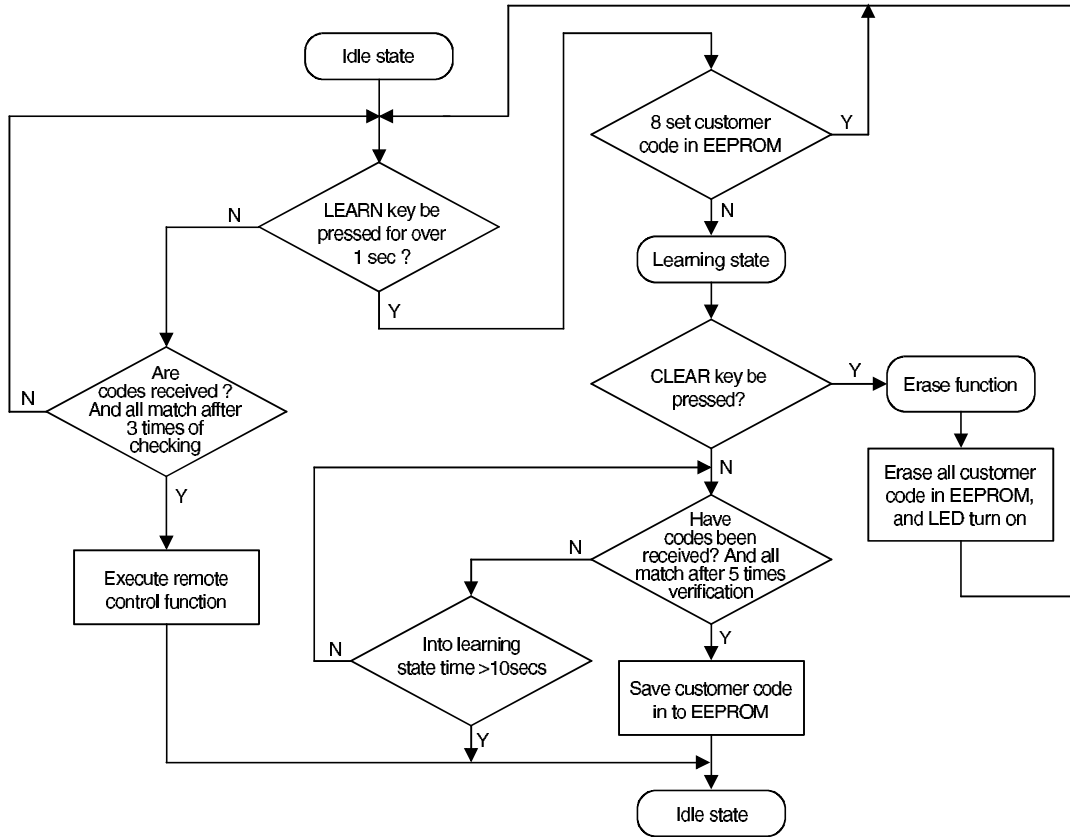

Application Circuits

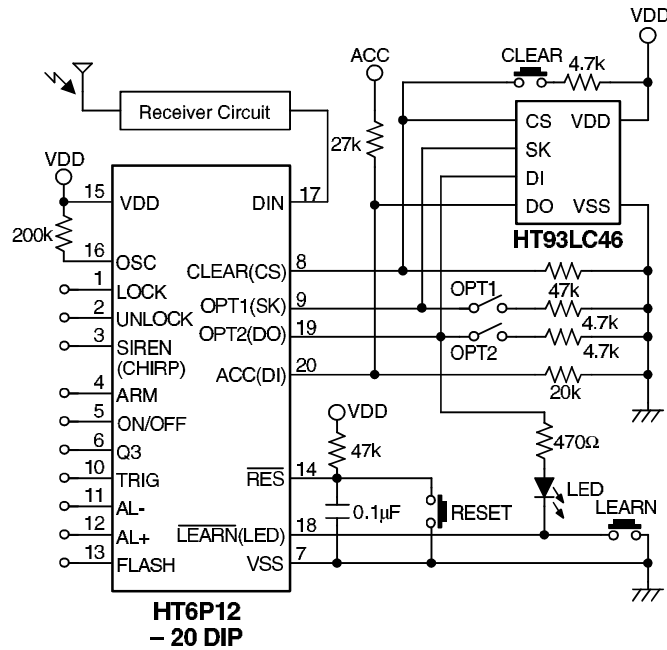
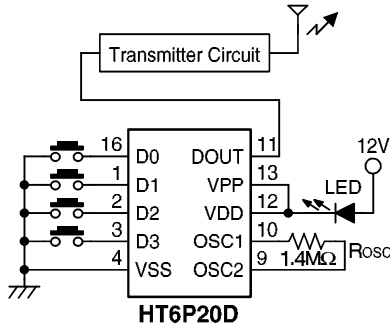

Note: Typical infrared receiver: PIC-12043T/PIC-12043S (DODESHI CORP.) or LTM9052 (LITEON CORP.)

Typical RF receiver: JR-200 (JUWA CORP.)

The key resistance must be less than 200Ω when the LEARN key is pressed