

DIGITAL SENSORLESS MOTOR DRIVE MODULE

IRMCT3UF1

Complete Integrated High Performance Sensorless Speed Control in a Compact, Ruggedized Package

- For up to 500VA, 3Phase Brushless DC and PMAC Sinusoidal Motors
- Ideal for Pumps, Fans, Compressors in Rugged Environments needing a Small Footprint
- Uses IR's iMOTION™ Digital Integrated Motor Drive Technology

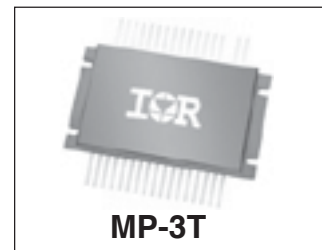

Description

IR's HiRel Digital Sensorless Motor Drive Module is a complete digital speed/torque controller ideal for applications demanding efficient operation in a compact and rugged package such as fuel pumps, fans, and compressors. This control is supported by the latest hardware motion control technology from IR, including the Servo Designer™ tools. No software code development is required due to its pre-configured Motion Control Engine.

The HiRel Motor Drive Module contains IR's advanced iMOTION™ Motion Control Chipset with monolithic Gate Driver ICs and state of the art 100V MOSFETs enabling simple and cost effective design of high reliability speed controls.

Feature Summary

- No Software - Digital Sine FOC Algorithm utilizes IR's New Hardware based Motion Control Engine
- Digital Configuration Interface supports Dynamic Re-Configuration of FOC
- Complete Digital Sine-Drive supports both 2 and 3-Phase Center Aligned and Assymetrical SVM Operation > 20KHz PWM Rate
- Ideal for Speed/Torque Control of High Performance Motors (> 25000 RPM)
- Speed/Torque command >10KHz Digital Speed Command Rate/Sampled Analog Command Input
- Control Loop Computation Time 11μsec
- Output Current up to 20Arms (48Vdc Bus)
- Max RS232C Speed 57.6 Kbps
- Stand-Alone Operation possible (without Host Micro)
- Lightweight Plastic Ring-Frame Enclosure
- Low R_{th} Insulated Metal Substrate (IMS) with Low R_{ds(on)} MOSFETs and IR's Advanced HVIC Gate Drivers
- Storage Temperature Range -55°C to +125°C
- Case Operating Temperature -40°C to +85°C
- Thermal Resistance 1.5°C/W

Electrical Characteristics @Tc = 25°C (Unless Otherwise Specified)

Parameter	Value
INPUT POWER	
Voltage	28Vdc to 48Vdc
Power Dissipation	12.5Watts
OUTPUT POWER	
Power	500VA Continuous
Phase Current	15Arms Continuous
	20Arms Overload
INTERFACE	
Diagnostic Interface (RS232C/422)	57.6Kbaud Single Ended
Analog Input	0-2.5V or 2.5-5.0V Input Reference Command
DISCRETE I/O	
Input	ON / OFF, Fault Clear
Output	FAULT
ANALOG FEEDBACK	
Current Sensing	Leg Shunt - (low side)
Voltage Sensing	Vbus Voltage Divider
Analog to Digital Converter	12 bit Resolution
PROTECTION	
Output Current Trip Level	500VA Version - 30A Peak
Over-Temperature Trip Level	110°C Min
Short Circuit Response Time	5.0 μ s
DC BUS VOLTAGE	
Maximum DC Bus Voltage	48V
Minimum DC Bus Voltage	20V
AMBIENT ENVIRONMENT	
Case Operating Temperature	-40°C to 85°C
Storage Temperature	-55°C to 125°C
POWER MODULE	
Power Stage	IMS contains 6 Mosfets
R _{th-JC}	1.5°C/W
Maximum Operating T _J (MOSFET)	150°C

Overview

The IRMCT3UF1 is a complete Sensorless drive system based on a proprietary digital motion control ASIC. The system is based on a configurable control engine implemented by hardware logics in the ASIC. The system has a simple and low cost structure, made possible by an advanced IR motion power components including the MOSFET module and IR2011 monolithic gate driver IC. These components together with the ASIC simplify hardware implementation. Since all control logic is implemented in hardware state machine as opposed to programmed software, unmatched parallel computation is achieved resulting in higher bandwidth control and higher motor operating frequency (< 25µsec PWM period).

Module Block Diagram

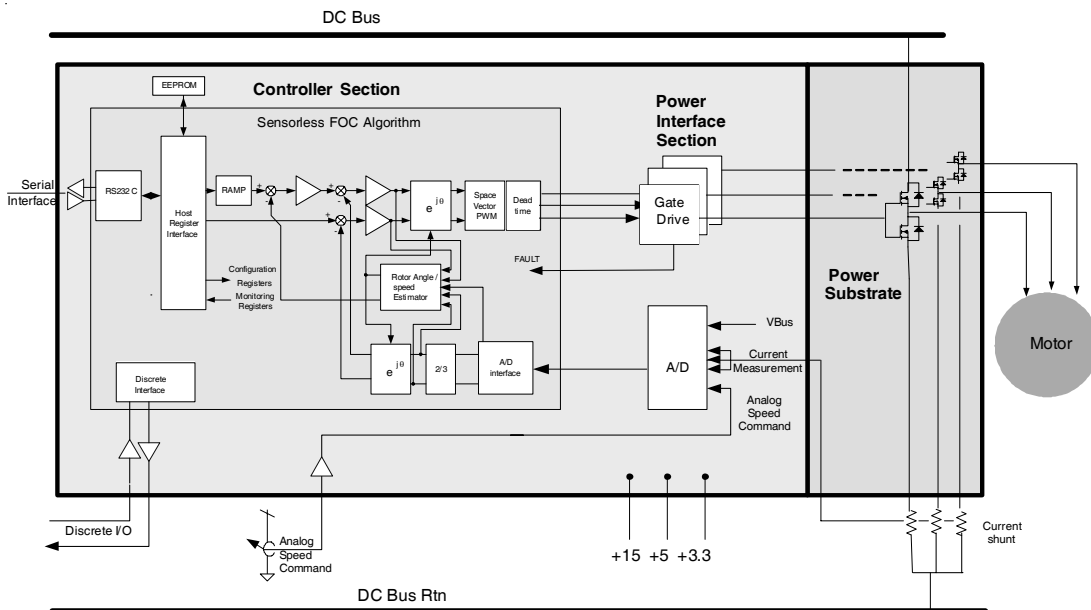

Application Diagram

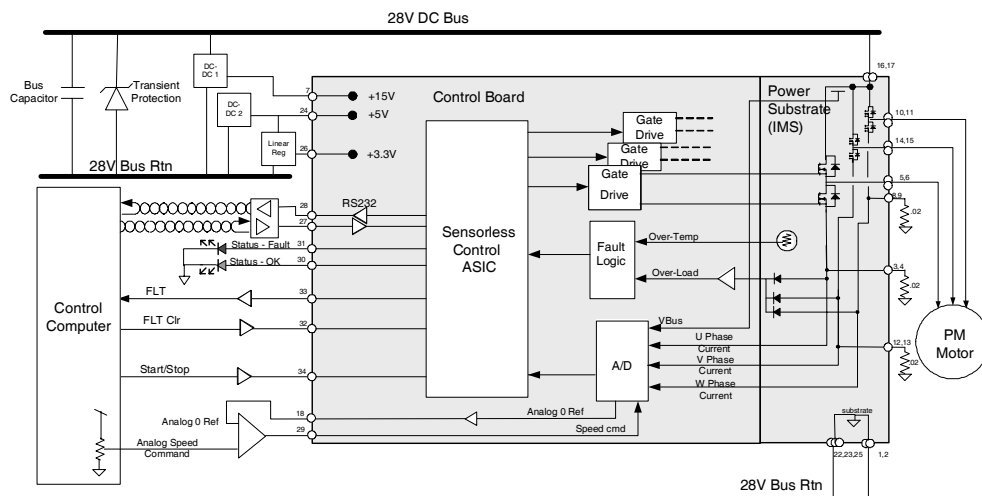

Pin Designation Table

Power Side		Control Side	
Pin #	Pin Description	Pin #	Pin Description
1	MOT_RTN	18	2.5V_REF_BUF
2	MOT_RTN	19	CS_LU (sense)
3	CS_LW	20	CS_LV (sense)
4	CS_LW	21	CS_LW (sense)
5	PHASE_W	22	GND
6	PHASE_W	23	GND
7	+15V	24	+5.0V
8	CS_LU	25	GND
9	CS_LU	26	+3.3V
10	PHASE_U	27	RX
11	PHASE_U	28	TX
12	CS_LV	29	SPD_CMD
13	CS_LV	30	GRN
14	PHASE_V	31	RED
15	PHASE_V	32	FLT_CLR
16	VBUS	33	FAULT
17	VBUS	34	START/STOP

Pin Descriptions

MOT_RTN (Pins 1, 2) - These two pins are connected to the motor bus voltage return path as well as the control power supply grounds.

CS_LW, CS_LU and CS_LV (Pins 3 & 4, 8 & 9, 12 & 13) - These pins are the current sense connections for corresponding motor phase. The pins on the power side are the output of the low side MOSFETs and must be connected to the current sense resistor in the external application. Each pin must also be connected to the corresponding current sense connection on the control side (see CS_LU, CS_LV, CS_LW description below).

PHASE_W, PHASE_U, PHASE_V (Pins 5 & 6, 10 & 11, 14 & 15) - Motor connections for the three phases.

VBUS (Pins 16 & 17) - Input voltage for the motor. The nominal value is 28Vdc with a maximum of 48V.

2.5V_REF_BUF (Pin 18) - 2.5V reference buffer provided for speed command referencing. (see SPD_CMD description)

CS_LU, CS_LV, CS_LW (Pins 19, 20 & 21) - Control side inputs from the current sense resistors. These monitor the voltage waveform at the top of the current sense resistor and use this signal to track the rotation of the motor. An approximate value for the resistor can be found using the Servo Designer software needed to configure the motor controller. The pins must be connected directly to the corresponding pins on the power side and care should be taken to make sure all three traces are approximately equal in length. Use low-inductance shunt resistors and keep leads short.

GND (Pins 22, 23 & 25) - Ground connections for the +15V, +5V and +3.3V power supplies. All three should be connected. This can be accomplished at the hybrid interface or by tying all three pins to a common ground plane.

+15V, +5.0V, +3.3V (Pins 7, 24 & 26) - Local housekeeping power supplies for the unit. The +15V power supply is used to drive the MOSFETs and should be rated at 100mA. The +5.0V and +3.3V supplies are responsible for the rest of the ICs in

the circuit including logic and the iMotion digital controller. The +5.0V supply should be rated at 100mA and +3.3V supply at 200mA.

RX, TX (Pins 27 & 28) - RS-232 interface pins for programming the controller. The interface operates at 57.6kBaud.

SPD_CMD (Pin 29) - Speed command for the motor controller. For the IRMCT3UF1, there are two operating ranges for the speed command input: 0-2.5V and 2.5-5V. In each case, 2.5V is zero speed and the other extreme (0V or 5V) is maximum speed. An external 2.5V reference is provided to help configure a particular speed command interface.

GRN, RED (Pins 30 & 31) - Outputs for driving Green and Red LEDs. These outputs are provided as a visual interface to determine the status of the drive. The Green LED output indicates a clear condition and the Red LED indicates that a Fault has occurred. Each output is referenced to +3.3V and is capable of driving a maximum current of 30mA. Also, each output has an internal series resistance of 100Ω.

FLT_CLR, FAULT (Pins 32 & 33) - Fault indication and Fault Clear function. Use these pins to monitor the Fault status of the controller. When there is no fault (clear condition), the fault pin is low. It goes to 3.3V upon the occurrence of a Fault. The controller can be reset by pulsing the Fault Clear pin high for a minimum of 1μs. This is a Schmitt input and is 5.5V tolerant.

START/STOP (Pin 34) - Start and Stop command for the controller. The drive will start on the rising edge of the command and will stop on the falling edge. This is a Schmitt input and is 5.5V tolerant.

Input / Output Characteristics

I/O	Pin Description	Parameter	Min.	Typ.	Max.	Units
Pins 30, 31	RED, GREEN	Reference Voltage	2.475	2.5	2.525	V
		Drive Current	1.0	-	30	mA
		Internal Series Resistance	-	100	-	Ω
Pins 32, 33	FAULT	No FAULT	-	-	0.2	V
		FAULT	3.3	-	-	
		Clear Pulse	1.0	-	-	μs
		Clear Pulse Amplitude	-	-	5.5	
Pin 29	SPEED COMMAND	0	-	2.5	-	V
		Max Speed 1	-	0	-	
		Max Speed 2	-	5.0	-	
Pin 7	+15V	Voltage	14.25	15	15.75	
		Load Current	-	100	-	mA
Pin 24	+5.0V	Voltage	4.75	5.0	5.25	V
		Load Current	-	100	-	mA
Pin 26	3.3V	Voltage	3.135	3.3	3.465	V
		Load Current	-	200	-	mA

Case Outline and Dimensions - MP-3T

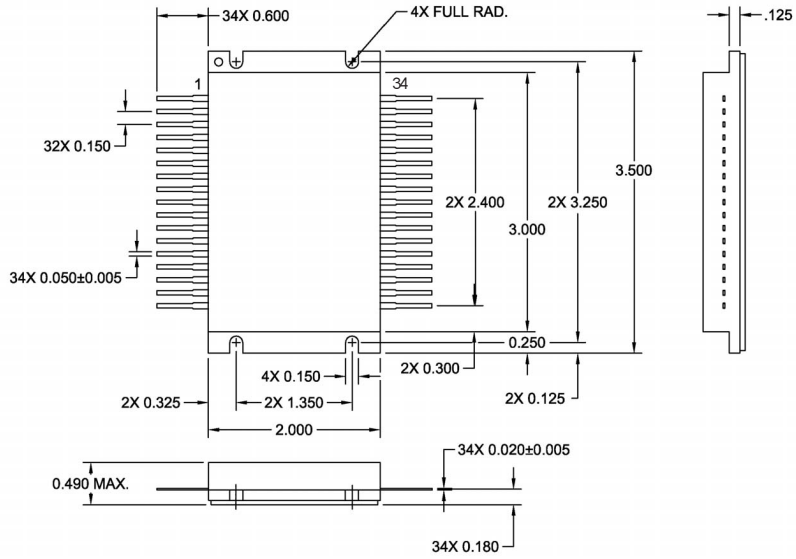

NOTES:

- 1.- DIMENSIONING AND TOLERANCING PER ASME Y14.5M-1994.
- 2.- CONTROLLING DIMENSION: INCH.
- 3.- DIMENSIONS ARE SHOWN IN INCHES.
- 4.- TOLERANCES ARE ± 0.010 U.O.S.
- 5.- SEE INDIVIDUAL DATA SHEETS FOR PIN ASSIGNMENTS.

Module Screening

Test	Method	Frequency Sampling
Internal Visual (Hybrids)	MIL-STD-883 TM2017	100%
Temperature Cycling	MIL-STD-883 TM1010 (20 Cycles -55°C To 125°C)	100%
Pre-Burn Electrical Test	Test Specification	100%
Burn-In-Static-Power Stage	MIL-STD-883 TM1015 Condition A (125°C, 160 hrs)	100%
Burn-In Active Hybrid	MIL-STD-883 TM1015 Condition A (85°C, 160 hrs)	100%
Final Electrical Test	Test Specification	100%
High Potential Test	MIL-STD-883 TM1003 Condition E (500 Vdc)	100%
Physical and Mechanical External Visual	MIL-STD-883 TM2009	100%

Part Numbering Nomenclature

