

MSC1075MP

RF AND MICROWAVE TRANSISTORS HF SSB APPLICATIONS

Features

- DESIGNED FOR HIGH POWER PULSED IFF, DME, TACAN APPLICATIONS
- 80 W (typ.) IFF 1030 – 1090 MHz
- 75 W (min.) DME 1025 – 1150 MHz
- 50 W (typ.) TACAN 960 – 1215 MHz
- 8.0 dB MIN. GAIN
- REFRACTORY GOLD METALLIZATION
- EMITTER BALLASTING AND LOW THERMAL RESISTANCE FOR RELIABILITY AND RUGGEDNESS
- INFINITE LOAD VSWR CAPABILITY AT SPECIFIED OPERATING CONDITIONS
- INPUT MATCHED COMMON BASE CONFIGURATION

DESCRIPTION:

The MSC1075MP is a gold-metallized silicon, NPN power transistor designed for applications requiring high peak power and low duty cycles, such as IFF, DME, and TACAN. It is packaged in the .280" input-matched stripline flange package, resulting in improved broadband performance and low thermal resistance.

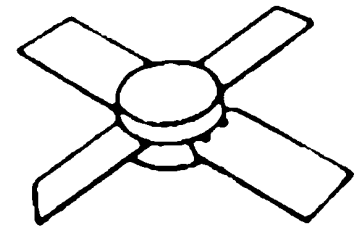

**.280 4LSL (M115)
hermetically sealed**

PIN CONNECTION

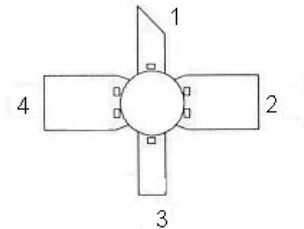

1. COLLECTOR 3. EMITTER
2. BASE 4. BASE

ABSOLUTE MAXIMUM RATINGS (T_{case} = 25°C)

Symbol	Parameter	Value	Unit
V _{CBO}	Collector-Base Voltage	65	V
V _{CES}	Collector-Emitter Voltage	65	V
V _{EBO}	Emitter-Base Voltage	3.5	V
I _C	Device Current	5.5	A
P _{DISS}	Power Dissipation	218.7	W
T _J	Junction Temperature	+ 200	°C
T _{STG}	Storage Temperature	-65 to +150	°C

THERMAL DATA

R _{TH(j-c)}	Junction-Case Thermal Resistance	0.8	°C/W
----------------------	----------------------------------	-----	------

ELECTRICAL SPECIFICATIONS (T_{case} = 25°C)

STATIC

Symbol	Test Conditions	Value			Units
		Min.	Typ.	Max.	
BV_{CBO}	I_C = 10 mA I_E = 0 Ma	65			V
BV_{CES}	I_C = 25 mA V_{BE} = 0 V	65			V
BV_{EBO}	I_E = 10 mA I_C = 0 mA	3.5			V
I_{CES}	V_{CE} = 50 V I_E = 0 mA			5	mA
h_{FE}	V_{CE} = 5 V I_C = .1 A	10			

DYNAMIC

Symbol	Test Conditions	Value			Units
		Min.	Typ.	Max.	
P_{OUT}	f = 1025 – 1150 MHz P_{IN} = 13.0 W V_{CE} = 50 V	75			W
G_P	f = 1025 – 1150 MHz P_{IN} = 13.0 W V_{CE} = 50 V	7.5			dB

Note: Pulse width = 10μSec. Duty Cycle = 1%
This device is suitable for use under other pulse width/duty cycle conditions.
Please contact the factory for specific applications assistance.

PACKAGE MECHANICAL DATA

PACKAGE STYLE M115

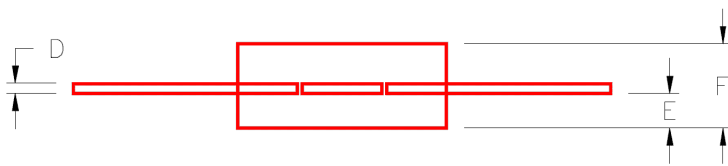
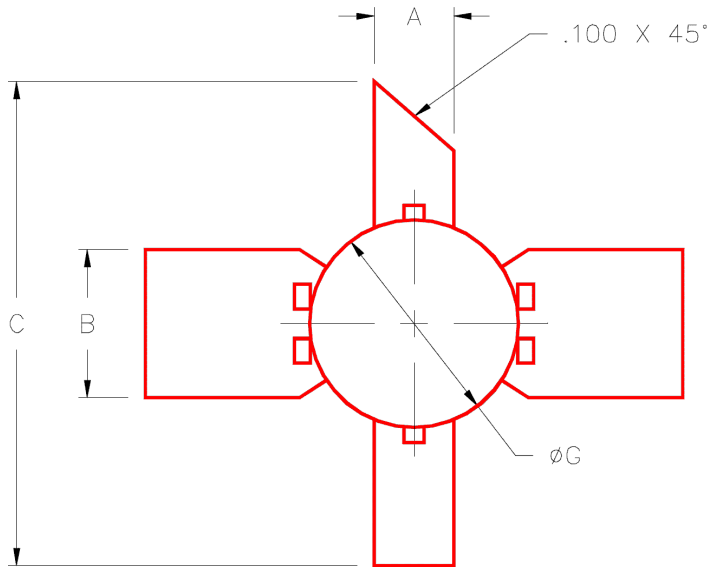

	MINIMUM INCHES/MM	MAXIMUM INCHES/MM		MINIMUM INCHES/MM	MAXIMUM INCHES/MM
A	.095/2,41	.105/2,67			
B	.195/4,95	.205/5,21			
C	1.000/25,40				
D	.004/0,10	.007/0,18			
E	.050/1,27	.065/1,65			
F	.120/3,05	.135/3,43			
G	.275/6,99	.285/7,21			