

AS8168**Single Phase Average Energy Metering IC
with On-Chip Calibration, Stepper Motor Drive and LED Output****DATA SHEET****Features**

- Extremely accurate, surpassing the accuracy requirements of the IEC1036 Specification with less than 0.1% error over a 1000 : 1 dynamic range
- On-chip programmable current input gain suitable for use with low-resistance shunt resistor or current transformer
- On-chip programming for output pulse rate selection.
- On-chip calibration eliminates the need for an external resistor network or trim-potentiometer
- Programmable on-chip creep prevention under no-load condition
- All on-chip programmable functions may be reprogrammed a second time
- Outputs directly drive an electromechanical counter or a two phase stepper motor counter and consumption LED indicator
- Fast calibration pulse output for high speed manual or automated calibration
- On-chip voltage reference and power supply monitoring
- Bi-directional or unidirectional energy measurement, with direction indication output available

Description

The AS8168 is a very accurate single-phase bi-directional average energy measurement integrated circuit, which surpasses all the accuracy requirements for IEC1036 alternating current static watt-hour meters. The measured energy is converted into pulses with the number of output pulses being proportional to the measured energy.

The AS8168 is ideal for use in 'stand alone' kWh meter applications, where the IC directly drives an electromechanical counter with a two-phase stepper motor, or for more complex meter applications, the AS8168 interfaces directly to a micro-controller.

The highly integrated AS8168 design includes all the required functional blocks. The blocks comprise of analog to digital converters (ADC) for the voltage and current channels, digital filters, a digital signal processing block, a control block and non-volatile calibration memory for the

on-chip programming. The on-chip programming enables the setting of the current input gain, the anti-creep threshold, the output pulse rates and the system calibration. The high level of integration ensures a minimum number of non-critical external components are required.

The on-chip anti-creep circuit ensures that the AS8168 does not output pulses when the meter is in a no-load condition and that the IEC1036 anti-creep test requirements are fully complied with, for both direct or transformer connection meters.

The AS8168 offers three different pulse outputs. A stepper motor drive output for directly driving a stepper motor display, a LED output for energy consumption indication and a dedicated high frequency output for fast single point system calibration.

The AS8168 is available in either surface mount SOIC-18 or dual-in-line DIP-18 packages.

Block Diagram

Figure 1 Block diagram of the AS8168

Typical Connection Circuit

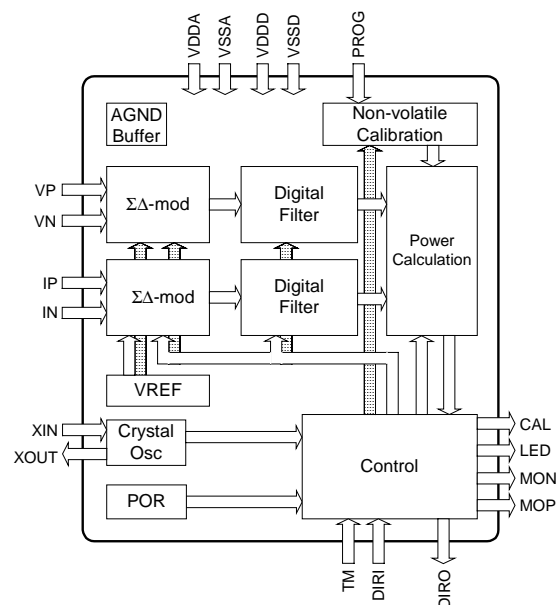
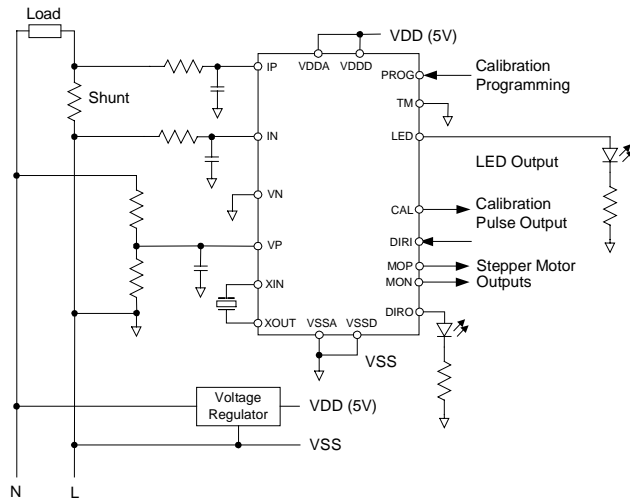

Figure 2 Typical connection circuit for the AS8168

Pin Configuration

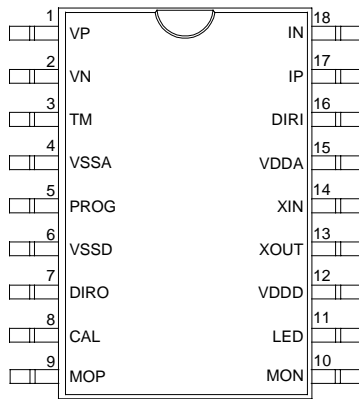
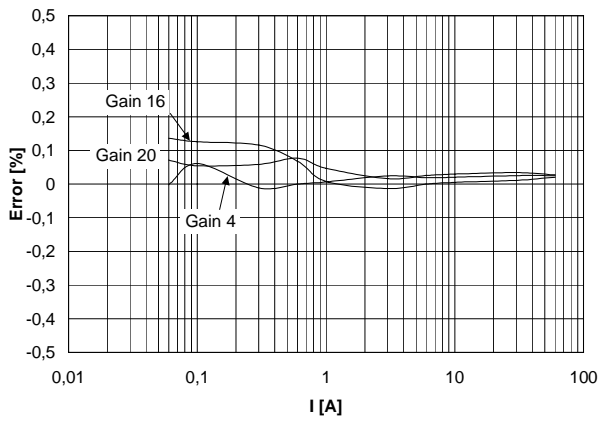

Figure 3 Pin configuration of the AS8168

Pin Description

Pin No.	Pin Name	Description
1	VP	Positive input for the voltage channel. VP is a differential input with VN. The differential voltage should be set at $\pm 150\text{mV}$ peak for rated voltage conditions. VP is an analog input pin.
2	VN	Negative input for the voltage channel. VN is a differential input with VP. VN is usually tied to 0V potential (VSSA). VN is an analog input pin.
3	TM	On 'power up', the test mode input defines the operation mode of the device. Either 'Normal Operation', or 'Calibration' modes may be selected. TM has an on-chip pull down resistor and should be left unconnected during 'Normal Operation'. TM must be set to logic '1' at 'power up' to set the device in 'Calibration' mode.
4	VSSA	Negative analog supply. VSSA is the ground reference for the on-chip analog circuitry.
5	PROG	Programming pin for calibration procedure. PROG is an analog input pin which must be left unconnected during normal operation. Note: PROG must not be connected to VSS.
6	VSSD	Negative digital supply. VSSD is the ground reference for the on-chip digital circuitry.
7	DIRO	Direction output provides indication of the direction of current flow through the current sensor. This digital input/output has an on-chip pull down resistor and provides logic '0' for positive power and logic '1' for negative power. DIRO is used as an input during the programming cycle. This output may be directly connected to a LED and is capable of driving 4mA.
8	CAL	Fast energy pulse output for calibration. CAL pulse rate is programmable and dependent upon the selected MON/MOP frequency.
9	MOP	Positive motor drive signal. MOP and MON are low frequency outputs for directly driving a two phase stepper motor. The frequency of the MOP/MON outputs is programmable to suite all industry standards and is capable of driving 10mA.
10	MON	Negative motor drive signal. MON and MOP are low frequency outputs for directly driving a two phase stepper motor. The frequency of the MOP/MON outputs is programmable to suite all industry standards and is capable of driving 10mA.
11	LED	This output may be connected to an LED to display energy consumption. LED is a digital output, which is programmable to a desired pulse rate. All the industry standard pulse rates are available. This output is capable of driving 10mA.
12	VDDD	Positive digital supply. VDDD provides the supply voltage for the AS8168 digital circuitry. The required supply voltage is $5\text{V} \pm 10\%$.
13	XOUT	See XIN below, for the connection of a crystal or ceramic resonator. When an external clock is applied to XIN, XOUT is not connected.
14	XIN	A 3.579545 MHz crystal or ceramic resonator may be connected across XIN and XOUT without the need for external load capacitors. Alternatively, an external clock signal may be applied to XIN.
15	VDDA	Positive analog supply. VDDA provides the supply voltage for the AS8168 analog circuitry. The required supply voltage is $5\text{V} \pm 10\%$.
16	DIRI	Direction input pin for selecting unidirectional or bi-directional energy measurement mode. When DIRI is at logic '0', the AS8168 is set in unidirectional mode. When DIRI is at logic '1' the AS8168 is in bi-directional mode. In default mode, when DIRI is not connected, the AS8168 is in bi-directional mode. DIRI is a digital input with an on-chip pull-up resistor.
17	IP	Positive input for the current channel. IP is a differential input with IN. The input gain is programmable depending on the desired current sensor. The maximum differential voltage is $\pm 150\text{mV}$ peak (Gain = 4). IP is an analog input pin.
18	IN	Negative input for the current channel. IN is a differential input with IP. The input gain is programmable depending on the desired current sensor. IN is usually at 0V potential. IN is an analog input pin.

AS8168 Performance Graphs



Graph 1: Error as a % of reading for gain settings 4, 16 and 20 at 25°C

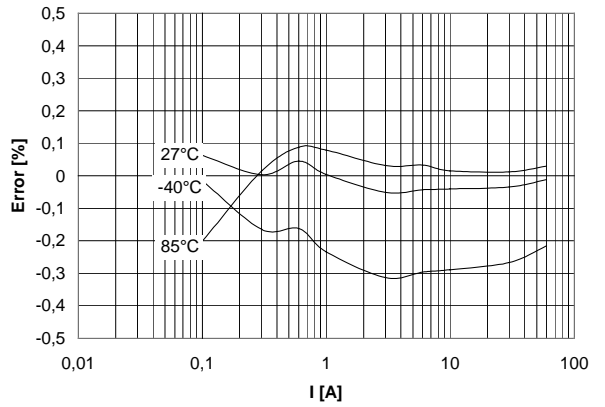

Graph 4: Error as a % of reading at temperature limits and PF = 0.5

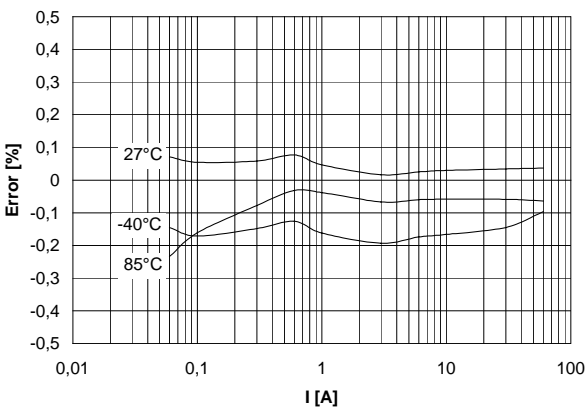

Graph 2: Error as a % of reading at temperature limits and PF = 1

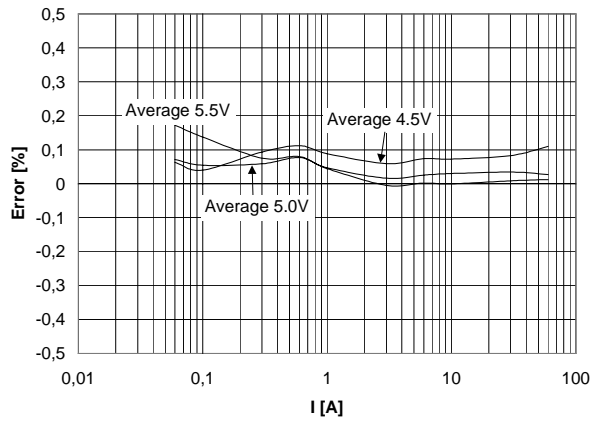

Graph 5: Error as a % of reading with variation in VDD

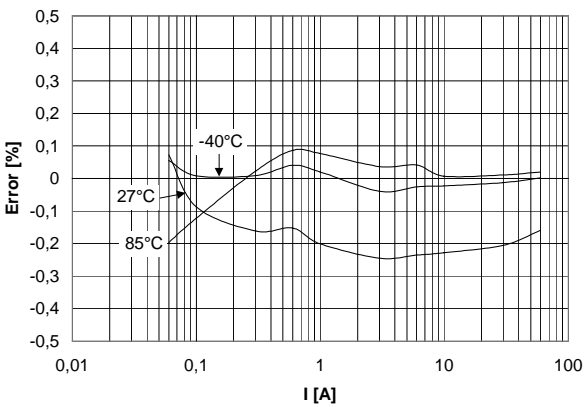

Graph 3: Error as a % of reading at temperature limits and PF = 0.8

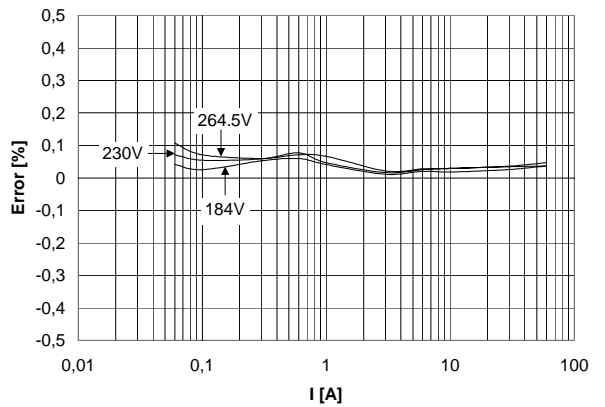

Graph 6: Error as a % of reading with mains voltage variation

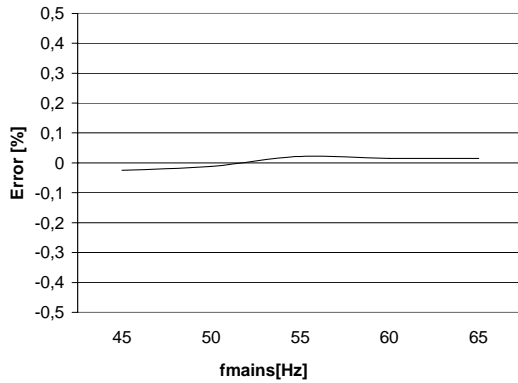

Graph 7: Error as a % of reading with mains frequency variation

Functional Description

The AS8168 is a CMOS mixed signal integrated circuit that measures electrical power over a dynamic range of 1000:1, to an accuracy of better than 0.1%.

The AS8168 comprises of standard functional blocks including two sigma/delta modulators, which convert the analog voltage and current input signals into digital signals. The voltage and current signals are then digitally filtered, which eliminates offsets thus enabling a single point calibration cycle. A power calculation block calculates the active energy value. An on-chip voltage reference (30ppm/K typical), oscillator and non-volatile calibration registers and control block for programming the AS8168 completes the core functional elements.

Programming of the AS8168 enables the device to be configured to suite the users specific input and output requirements and allows for fast and efficient calibration. The AS8168 device provides the user with two complete opportunities to programme the device. The following parameters may be programmed via the on-chip non-volatile memory:

- Current channel input gain
- Calibration pulse output frequency
- Stepper motor output drive frequency
- LED output frequency
- Anti-creep threshold
- Calibration constant

A detailed description of the versatility of the AS8168 is given below.

Current Inputs for Energy Calculation

The current channel input consisting of inputs IP and IN is differential and connected to a low resistance shunt or current transformer, in series with the load. The current input signal level may be programmed by means of an on-chip programmable gain amplifier (PGA). The gain is selected through the programming of 2 bits in the on-chip memory as follows:

Parameter: **Gain**

Setting	Voltage Gain	Input Voltage	Comments
1 1	20	$-30\text{mV}_{\text{peak}} \leq V_{\text{IP}} \leq 30\text{mV}_{\text{peak}}$	Shunt mode
1 0 0 1	16	$-38\text{mV}_{\text{peak}} \leq V_{\text{IP}} \leq 38\text{mV}_{\text{peak}}$	CT mode
0 0	4	$-150\text{mV}_{\text{peak}} \leq V_{\text{IP}} \leq 150\text{mV}_{\text{peak}}$	CT mode

For optimum operating conditions, the input signal at the Maximum Current (I_{max}) condition should be set at $\pm 30\text{mV}$ peak, when the input Gain = 20, or $\pm 150\text{mV}$ peak, when the input Gain = 4.

The default gain, namely the AS8168 setting which is available without any programming required, is Gain = 20.

The value of an ideal shunt resistor, may be calculated as follows:

Assuming an I_{max} rating of 60A (rms) \rightarrow 84.85A (peak), then a shunt value of $350\mu\Omega$ would be suitable.

$$R_{shunt} = \frac{30\text{mV}_{peak}}{84.85\text{A}_{peak}} = 350\mu\Omega$$

The mains current is sampled at 1.7478kHz, assuming that the recommended crystal oscillator frequency of 3.5795MHz, is used.

Voltage Input for Energy Calculation

The voltage channel input consists of inputs VP and VN, which are differential, with VP connected to the tap of a resistor divider circuit of the line voltage and VN connected to Ground. For optimum operating conditions, the input signal at VP with respect to VN, should be set at 150mV peak for the rated line voltage condition.

The maximum voltage on VP for the specified operation is 210mV with respect to VSS. The maximum allowed voltage signal at VP, which ensures that pulses are still provided at the output, is 300mV with respect to VSS. Both VP and VN have internal ESD protection and an over-voltage of $\pm 7\text{V}$ can be sustained on these pins without risk of permanent damage to the device.

The resistor values for an ideal voltage divider, may be calculated as follows:

Assuming a V_{mains} of 230V (rms) \rightarrow 325V (peak) and according to the voltage divider shown below, the value for $R_2 = 820\Omega$, the value of R_1A+R_1B may be calculated as follows:

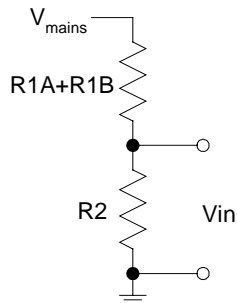

$$R_1A + R_1B = R_2 * \frac{(V_{mains(peak)} - V_{IP max})}{V_{IP max}} = 820\Omega * \frac{325V - 150\text{mV}}{150\text{mV}} = 1.77\text{M}\Omega$$

The mains voltage is sampled at 1.7478kHz, assuming that the recommended crystal oscillator frequency of 3.5795MHz is used.

Digital Filters

The current and voltage channels have been identically implemented with digital high pass filters in both channels, thus eliminating offsets.

The filters ensure that there are no phase errors introduced between the voltage and current channels, enabling single point calibration.

Energy to Pulse Output Conversion

The energy value is accumulated in the energy accumulator and compared with the default or programmed threshold level, following each sample. The threshold represents the *pulse equivalent energy value*. If the energy value goes above the threshold, a pulse is generated and presented to the output. Each time a pulse is generated the threshold value is subtracted from the contents of the energy accumulator.

The remaining energy, namely the energy value above the threshold value is retained in the accumulator. Further measured energy is added to the retained value in the accumulator and a pulse is again generated and presented to the output, when the value again exceeds the threshold value. Thus no energy is lost during the energy to pulse output conversion process. The voltage and current signals are sampled at 1.7478kHz. The sample rate is derived from the main clock (F_{MCLK}) as follows:

$$3.57945 \text{ MHz} / 8 \cdot 256 = 1.7478 \text{ kHz}$$

The number of measured harmonics is defined by the sample rates of the voltage and current input signals. The maximum bandwidth, which is half the sample frequency, is calculated as follows:

$$1.7478/2 \text{ kHz} = 873.9 \text{ Hz}$$

Thus, depending on the mains frequency, the measured energy is up to the following harmonics:

50Hz mains = 17th harmonic

60Hz mains = 14th harmonic

Energy Pulse Outputs

The AS8168 has three different pulse outputs. All the outputs are derived directly from the measured energy; thus, the outputs can be used for energy accumulation and for calibration purposes. The output options include the following:

- CAL: A higher pulse rate output for fast calibration
- MOP/MON: Low pulse rate outputs for directly driving a stepper motor
- LED: A low pulse rate output which may be used to directly drive a LED for displaying power consumption

Calibration Pulse Output (CAL): The CAL output is a high frequency output, the frequency of which is proportional to the real power measured.

The output pulse rate is programmable via the on-chip memory and allows for 4 pulse rate options:

Parameter: ***F_cal_sel***

Setting	CAL Output Pulse Rate
00	MON/MOP x 8
01	MON/MOP x 16
10	MON/MOP x 32
11	MON/MOP x 64

The default pulse rate of CAL is MON/MOP x 16. The default pulse rate is the pulse rate available at the output, without any programming required to the AS8168.

(Note: As the default pulse rate of MON/MOP is 400 imp/kWh, the actual CAL default pulse rate is $400 \times 16 = 6,400$ imp/kWh)

As an example, the maximum selectable pulse rate of CAL is $64 \times 800 = 51,200$ imp/kWh (See MON/MOP below)
The CAL pulse width is fixed at 1ms and is shown in the *Timing Diagram* and *Timing Parameters* that follow.

Stepper Motor Drive Outputs (MON & MOP): The MON and MOP outputs may be used to directly drive an electromechanical counter or a stepper motor counter. The output frequencies are proportional to the real power measured. The required format of the signal for driving a mechanical counter, activated by a 2-phase stepper motor is provided by the difference between the MON and MOP outputs.

The output pulse rate is programmable via the on-chip memory, with 4 pulse rate options being available:

Parameter: ***F_mon_sel***

Setting	MON/MOP Output Pulse Rate
00	100 imp/kWh
01	200 imp/kWh
10	400 imp/kWh
11	800 imp/kWh

The default MON/MOP pulse rate is set at 400 imp/kWh. The default pulse rate is the pulse rate available at the output, without any programming required to the AS8168.

The MON and MOP outputs shown in Figure 4 are capable of driving 10mA at $V_{OH} = 4.0V$ and $V_{OL} = 0.4V$.

The widths of the MON/MOP pulses are 200ms for all settings up to 800 imp/kWh. Above 800imp/kWh, the MON/MOP pulse widths maintain a constant 50% duty cycle and is shown in the *Timing Diagram* and *Timing Parameters* that follows.

LED Driver Pulse Output (LED): The LED output is a low frequency output, the frequency of which is proportional to the real power measured. The pulse rate is programmable via the on-chip memory the selected pulse rate is independent of the settings of both the selected CAL and the MON/MOP settings.

Parameter: ***F_led_sel***

Setting	LED Output Pulse Rate
000	100 imp/kWh
001	200 imp/kWh
010	400 imp/kWh
011	800 imp/kWh
100	1600 imp/kWh
101	3200 imp/kWh
110	6400 imp/kWh

The default LED pulse rate is set at 3200 imp/kWh. The default frequency is the frequency available at the output, without any programming required to the AS8168.

The LED output is capable of driving 10mA at $V_{OH} = 4.0V$ and $V_{OL} = 0.4V$.

The width of the LED pulse is 80 ms for all settings except where the LED stream is shorter than 160ms. In this case, a 50% duty cycle is maintained. The format of the LED signal is shown in the *Timing Diagram* and *Timing Parameters* below.

Anti-Creep Threshold Setting

The anti-creep threshold is programmable to ensure that the set threshold lies between the anti-creep current, a current level at which no pulses must be generated and the start current. The programmable threshold levels have been set to accommodate the various specified base currents (I_B) of the meter and if the meter is direct connection (shunt resistor) or connection is through a current transformer. The formulae for calculating the appropriate thresholds are as follows:

$$\text{Shunt: } ac_th = \frac{4 * I_B}{1000} * \frac{1}{5} = I_{Start} * \frac{1}{5}$$

$$\text{Current Transformer: } ac_th = \frac{2 * I_B}{1000} * \frac{1}{5} = I_{Start} * \frac{1}{5}$$

Parameter: ***Acreep_sel***

(All values are given in mA, unless otherwise specified)

Setting	$I_{threshold}$	I_B (A)	$I_{max}(A)$ ($I_B * 4$)	$I_{max}(A)$ ($I_B * 6$)	$I_{anticreep}$ Shunt	$I_{starting}$ Shunt	$I_{anticreep}$ CT	$I_{starting}$ CT
00	2.3	1.5	6	9	1.2	6	0.6	3
	2.3	2.5	10	15	2	10	1	5
01	7.4	5	20	30	4	20	2	10
10	14.8	10	40	60	8	40	4	20
	14.8	15	60	90	12	60	6	30
11	29.7	20	80	120	16	80	8	40
	29.7	30	120	n/a	20	100	10	50

The default anti-creep threshold (ac_th) is set at 7.4mA, best suited to a 30A ($I_B * 6$) or 20A ($I_B * 4$) meter. The default anti-creep is the programmed threshold setting, without any programming required to the AS8168.

Summary of Programmable Parameters

The AS8168 programming options, along with the default settings have been summarised in the table below:

I Gain	CAL	MON/MOP	LED	Anti-Creep Threshold
20	8	100	100	2.32mA
16	16	200	200	7.43mA
4	32	400	400	14.90mA
	64	800	800	29.70mA
			1600	
			3200	
			6400	

Note: The default settings have been highlighted.

Timing Diagram

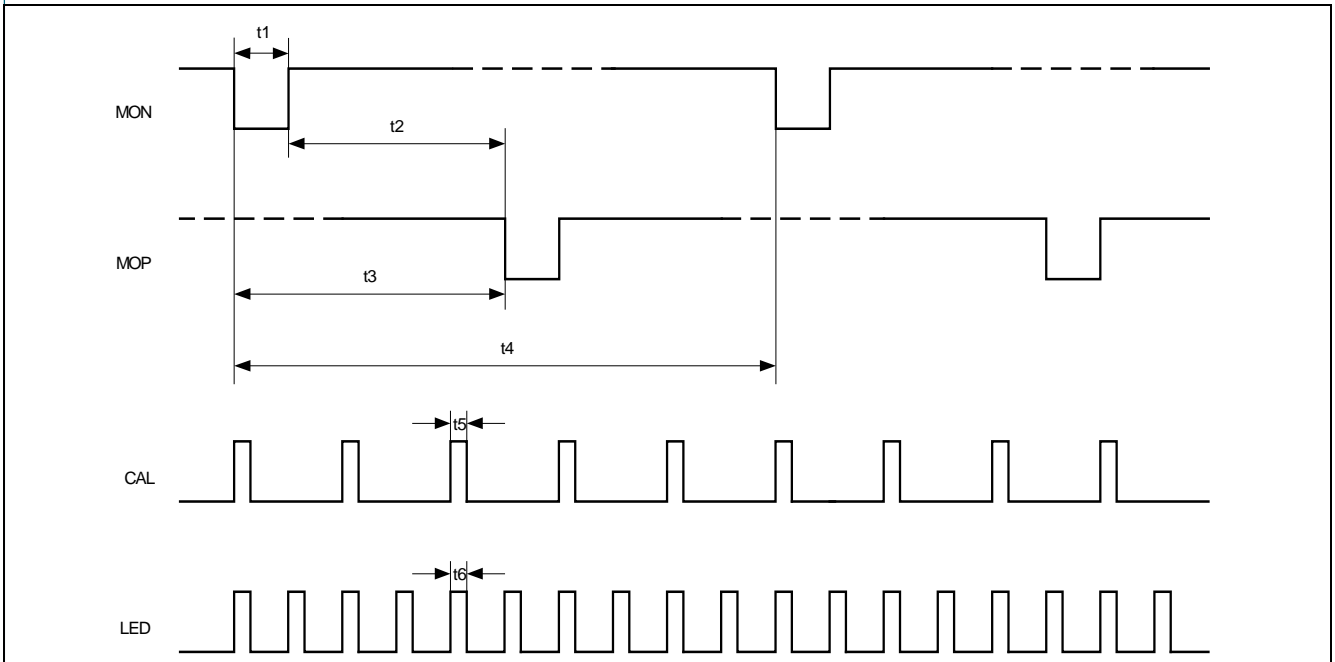

Figure 4 Timing diagram for AS8168 frequency outputs

Timing Parameters

Parameter	Values	Unit	Pulse rate	Comments
t1	200	ms	100,200,400 imp/kWh	For all currents up to 120A ; 230V
	200	ms	800 imp/kWh	$I_{max} < 97.8A$; 230V
	50% duty cycle		800 imp/kWh	$I_{max} > 97.8A$; 230V
t2	$T_{osc} \cdot 4$	ms		Minimum time between MON and MOP
t3	$t_1 + t_2$	ms	100,200,400,800 imp/kWh	
t4	$2 \cdot t_3$	ms	50,100,200,400 imp/kWh	
t5	1	ms		
t6	80	ms	100,200,400,800 imp/kWh	For all currents up to 120A; 230V
	80	ms	1600 imp/kWh	For currents below 61.14A; 230V
	50% duty cycle		1600 imp/kWh	For currents above 61.14A; 230V
	80	ms	3200 imp/kWh	For currents below 30.57A; 230V
	50% duty cycle		3200 imp/kWh	For currents above 30.57A; 230V
	50% duty cycle		3200 imp/kWh	For currents above 61.14A; 230V
	80	ms	6400 imp/kWh	For currents below 15.28A; 230V
	50% duty cycle		6400 imp/kWh	For currents above 15.28A; 230V
	50% duty cycle		6400 imp/kWh	For currents above 30.57A; 230V
	50% duty cycle		6400 imp/kWh	For currents above 61.14A; 230V

Direction Input (DIRI)

The direction input pin (DIRI) is used to program the AS8168 for either bi-directional energy measurement, or unidirectional measurement.

Bi-directional measurement mode ensures that all energy is measured regardless of the direction of the current through the current sensor. In unidirectional energy measurement mode, all negative going energy is suppressed and thus excluded from the accumulated energy value.

The programming conditions for the DIRI pin are given below:

DIRI Pin	Mode
0	Unidirectional
1	Bi-directional

The default condition, when the DIRI pin is not connected is bi-directional energy measurement, as the DIRI pin has an on-chip pull-up resistor.

Direction Output (DIRO)

The Direction Output pin (DIRO) is a logic output providing information on the direction of the current flow through the current sensor. The DIRO output may be used to directly drive an LED to indicate a reversal in the direction of current flow.

The conditions that will initiate a change in the DIRO logic output are given below:

If DIRI = 1 (bi-directional mode) DIRO changes only when there is a pulse at CAL or LED.

If DIRI = 0 (unidirectional mode) DIRO changes at a zero-crossing when not in anti-creep.

The timing diagram below demonstrates the operation of the DIRO output and the pulse outputs (MOP/MON, CAL and LED) relative to the sign of the measured energy and the setting of the DIRI input.

For illustration purposes, the timing diagram below only shows the LED output.

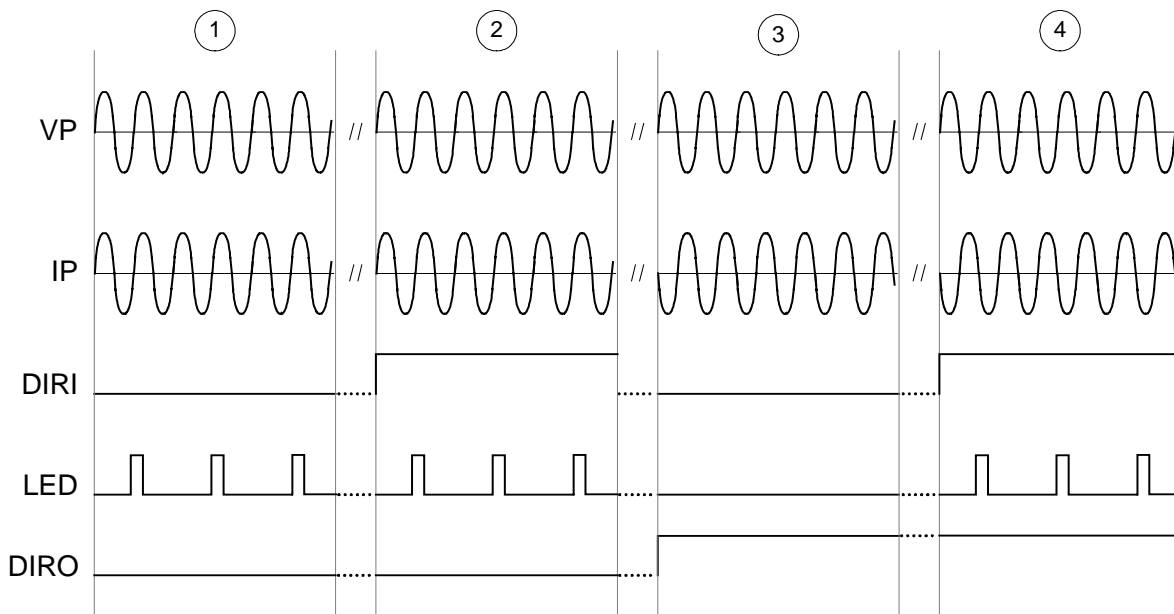

Figure 5 Timing diagram for the DIRI and DIRO functions

The timing diagram above demonstrates the state of both the LED and DIRO output pins depending on the input conditions:

1. The voltage input (VP) and current input (IP) are in phase and the direction input DIRI is set to 'Unidirectional' mode. Pulses are available at the LED output and DIRO indicates a positive energy flow.
2. The voltage input (VP) and current input (IP) are in phase and the direction input DIRI is set to 'Bidirectional' mode. Pulses are available at the LED output and DIRO indicates a positive energy flow.
3. The voltage input (VP) and current input (IP) are out of phase and the direction input DIRI is set to 'Unidirectional' mode. Pulses are no longer available at the LED output as negative going energy is not measured. The direction output DIRO indicates a change in direction of the input current at IP.
4. The voltage input (VP) and current input (IP) are out of phase. The direction input DIRI is set to 'Bidirectional' mode. Pulses are again available at the LED output and the direction output DIRO indicates a change in direction of the input current at IP.

Crystal Oscillator

The AS8168 has an on-chip crystal oscillator, with the recommended 3.5795MHz crystal connected to the XIN (Crystal Input) and XOUT (Crystal Output) pins. The 3.5795MHz crystal is recommended, as it is a standard low cost component.

Alternatively, an external clock signal may be applied to XIN. In this case, XOUT should not be connected.

Test Mode (TM)

On 'power up', the test mode input defines the mode of operation of the device. Either 'Normal Operation', or 'Programming' modes may be selected. TM has an on-chip pull down resistor and should be left unconnected during 'Normal Operation'. TM must be set to logic '1' at 'power up' to set device in 'Programming' mode.

The AS8168 programming procedure is defined in detail in the following paragraphs.

Power Supply Monitor

The AS8168 has an on-chip power supply monitor (PSM) which resets the complete device once the supply voltage drops below the specified threshold of $3.5V \pm 5\%$.

Programming the AS8168

The AS8168 is a programmable device, which uses on-chip zener diodes to permanently program specific data such as current input channel gain, pulse-level, meter constant settings and system calibration. This programming operation is also called 'burn' which relates to the permanent physical change of the on-chip zener diodes electrical behavior. Another term for 'permanent programming' is OTP (One-Time-Programming).

Two banks of zener diodes are available in the AS8168 in order to allow a second calibration. By programming the 2nd bank of zener diodes, this bank will subsequently be used (bank-select-bit). During power-up of AS8168, a readout of all zener diodes occurs and the data of the active bank is used.

The AS8168 may also be used with the default operating parameters, which have been defined earlier in this document. If the user wishes to alter the operating parameters, the AS8168 may simply be programmed to provide the required operating parameters. Fast meter system calibration may also be carried out as part of the AS8168 programming procedure, providing long term meter system stability.

The AS8168 can be operated in one of two modes. The two modes are:

- Normal Operation Mode: Normal operation is the mode in which the device operates to perform the kWh metering function, for which the device is designed.
 - Programming Mode: Programming is the mode in which the AS8168 is set to perform the programming operations. When in Programming mode, two different operations may be carried out:
 - Test Write: Test Write enables the writing of data to a register in the device and for the resultant chip behaviour to be investigated, before the data is written permanently to the non-volatile PROM (programmable read only memory) memory.
 - Burn: Burn is the programming cycle that ensures that the required data is permanently written to the non-volatile PROM (programmable read only memory).
- During Programming mode all pulse outputs (MOP/MON, CAL and LED) can be accessed.

The AS8168 may only be set up in one of these two modes during the 'power up' cycle of the device. The mode is selected by programming the TM and DIRO at 'power up' as shown in the table below:

Mode of Operation	TM	DIRO
Normal Operation	0	X
Programming	1	0

Note: Pin DIRO has an on-chip internal pull-down resistor, thus the pin may be left open or tied 'low' for both Normal Operation and Programming modes. The default mode is thus Normal Operation mode, with the AS8168 only being set to Programming mode when TM is pulled high during power up.

The analog input pin PROG is also required for the programming of the AS8168. During Test-Write PROG is used to transfer digital data to the internal register. During Burn it is used to change the states of the internal PROM cells.

When in Programming mode, the AS8168 must be powered down before the device can enter Normal Operation mode.

PROM Definition and Contents

The table below provides a definition of the internal PROM cells. As shown, sets of PROM cells form binary words, which represent, for example, a defined pulse rate.

Parameter	Description	Number of bits	Register bits		Settings	Default
			Bank 0	Bank 1		
Gain	Select current channel gain	2	[34:33]	[67:66]	00 : 4 01 : 16 10 : 16 11 : 20	11
Acreep_sel	Select anti creep threshold	2	[32:31]	[65:64]	00 : 2.32mA 01 : 7.43mA 10 : 14.9mA 11 : 29.7mA	01
F_mon_sel	Select MOP/MON pulse rate [imp/kWh]	2	[30:29]	[63:62]	00 : 100 01 : 200 10 : 400 11 : 800	10

Parameter	Description	Number of bits	Register bits		Settings	Default
F_cal_sel	Select multiplier for CAL pulse rate related to MOP/MON pulse rate	2	[28:27]	[61:60]	00 : 8 01 : 16 10 : 32 11 : 64	01
F_led_sel	Select LED pulse rate [imp/kWh]	3	[26:24]	[59:57]	000 : 100 001 : 200 010 : 400 011 : 800 100 : 1600 101 : 3200 110 : 6400	101
Pulse_lev	Central pulse_level value	22	[23:2]	[56:35]		0x6A6D4
Bank01	Select PROM bank 0 or 1	1	[1]		0 : Bank 0 1 : Bank 1	0
Sel_def	Select default or programmed values	1	[0]		0 : default 1 : programmed Value	0
	Not used	2	[69:68]			00
	Total	70				

The "Default" values are *hard coded* on-chip outside the PROM block. Only once the **Sel_def** bit has been set, are the PROM parameters selected by the AS8168.

Two PROM banks are defined as 'Bank 0' and 'Bank 1'. This feature allows for a complete reprogramming cycle if necessary. The required bank is selected with the bit called **Bank01**.

The calibration of the AS8168 adjusts the specific pulse-level (Pulse_lev), which defines exactly the energy level when a pulse has to be generated and presented to the output. This pulse-level is used to define a very fast internal pulse rate from which the external pulse outputs are derived. Therefore, the AS8168 is extremely flexible in defining pulse output rates as required for a specified kWh meter.

The parameters **F_mon_sel**, **F_cal_sel** and **F_led_sel** are used to define the pulse rates for the pins MOP/MON, CAL and LED.

The **Acreep_sel** bit defines the threshold for the current for when no pulses should be transmitted.

Calculations for Calibration

This paragraph describes how to successfully calibrate the AS8168 device. The parameter **Pulse_lev** is the main parameter to determine the basic internal (very fast) frequency. This frequency relates to the measured power and is the basis from which all the output pulse rates namely, MOP/MON, CAL and LED are derived.

Prior to system calibration, the appropriate value for the parameter **Pulse_lev** must be calculated to produce the required output pulse rates for MOP/MON, CAL and LED. The calibration exercise must accommodate all system non-idealities that are present in the meter system.

There are two calibration methods available to find the appropriate value of **Pulse_lev**, namely:

- Defined current and calibration time method
- Comparison method

It is also possible to perform:

- Calibration without on-chip programming

Defined Current and Calibration Time Method

The AS8168 generates a pulse whenever the internal energy accumulator contains a value, which is greater than a programmed threshold. This threshold is the parameter **Pulse_lev**. This parameter depends on the basic meter properties, the mains voltage V_{mains} and the maximum current to be measured, I_{max} . Furthermore, it is assumed that through a resistor divider V_{mains} is scaled down to match the maximum input range of the VP input.

Firstly, an ideal value for **Pulse_lev** is calculated. This is the value, which would have to be programmed into the AS8168 device if the meter system was perfect.

The following formula calculates this ideal value of **Pulse_lev**:

$$\text{Pulse_lev(ideal)} = \frac{230\text{V}}{V_{\text{mains}}} * \frac{20\text{A}}{I_{\text{max}}} * 435924$$

A calibration is performed to compensate for system non-idealities like resistor tolerances etc. The effect of these non-idealities is that with the ideal **Pulse_lev** value the pulse rates will not be correct. In order to calibrate the meter, a new **Pulse_lev** value has to be found. Figure 6 shows the basic calibration setup. CAL pulses from a meter built with the AS8168 are counted during a defined time period **tc**, while an accurately defined calibration current **Ical**, is being measured.

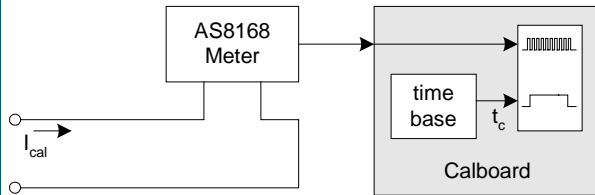

Figure 6 Basic calibration setup for defined current and calibration time method

Again, if the system was perfect we would expect a certain number of pulses to be counted, the ideal number of pulses, **Ni**:

$$N_i = \frac{\text{PR} * t_c * V_{\text{mains}} * I_{\text{cal}}}{3600 * 1000}$$

where t_c is in seconds.

PR is the pulse rate on pin CAL, which can be calculated from the PROM parameters **F_mon_sel** and **F_cal_sel**:

$$\text{PR} = F_{\text{mon}} * F_{\text{cal}}$$

where **Fmon** [imp/kWh] is the pulse rate selected by **F_mon_sel** and **Fcal** is the multiplier selected by **F_cal_sel**.

If pin LED is used for calibration then PR is the pulse rate on pin LED (selected by **F_led_sel**).

The corrected value for **Pulse_lev** can now be calculated using the following formula:

$$\text{Pulse_lev}(\text{corrected}) = \text{Pulse_lev}(\text{ideal}) * \frac{N_r}{N_i},$$

where N_r is the real number of pulses, i.e. the number of pulses counted during t_c .

A logical flow of the described calculations, is shown below:

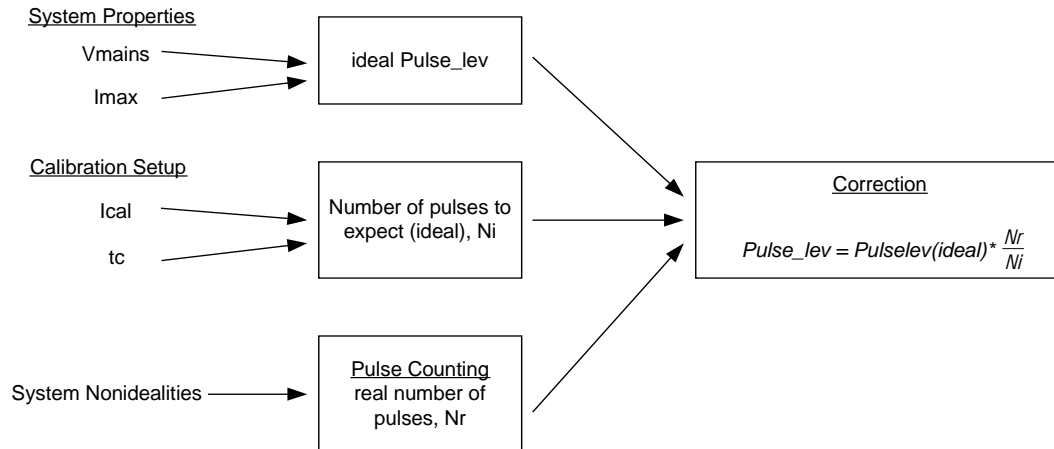

Example

Calibrate a meter with $V_{\text{mains}} = 230\text{V}$, $I_{\text{max}} = 40\text{A}$ and $I_{\text{cal}} = 10\text{A}$. Calibration time is 20 seconds, the PROM settings for the pulse rates are: $F_{\text{mon}}: 200 \text{ imp/kWh}$, $F_{\text{cal}}: 64$

$$\text{Pulse_lev}(\text{ideal}) = \frac{230\text{V}}{230\text{V}} * \frac{20\text{A}}{40\text{A}} * 435924 = 217962$$

The ideal number of pulses during 20 seconds of calibration is:

$$N_i = \frac{200 \text{ imp/kWh} * 64 * 20\text{s} * 230\text{V} * 10\text{A}}{3600 * 1000} = 163.56 \text{ imp} \approx 164 \text{ imp}$$

Thus 164 pulses are expected during the 20 seconds calibration time. (For this example it is not important what error is introduced with this setting!).

Assuming that 170 pulses were actually counted. The real pulse level may then be calculated:

$$\text{Pulse_lev}(\text{real}) = 217962 * \frac{170}{164} = 225936.2 \approx 225936$$

This pulse level must then be written to the PROM so that N_r equals N_i .

Comparison Method

Most common, is the comparison of energy reading of the meter under test against a standard or reference meter. Normally, the standard, or reference meter has a considerably higher pulse rate than the meter under calibration. In this case, the absolute calibration time is not important for the calculations. The basic calibration setup is shown below:

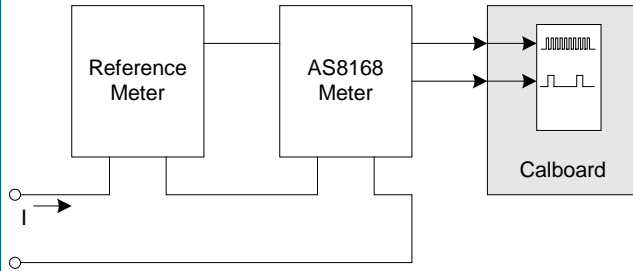

Figure 7 Basic calibration setup for comparison calibration method

The standard or reference meter pulses are counted between two or more pulses from the meter to be calibrated. Ideally the sum of the pulses would exactly be the ratio between standard meter pulse rate and the pulse rate of the meter under test. From the deviation the corrected **Pulse_lev** may be calculated.

$$\text{Pulse_lev}(\text{corrected}) = \text{Pulse_lev}(\text{ideal}) * \frac{N_i}{N_r},$$

Where N_r is the number of pulses counted from the standard or reference meter and N_i is the ratio between the pulse rates, which is always >1 . The formula for N_i is as follows:

$$N_i = \frac{\text{PR}(\text{ref})}{F_{\text{mon}} * F_{\text{cal}}},$$

This is assuming that the CAL pulse output is used for calibration. If the LED pulse output is used for calibration, the following formula should be used:

$$N_i = \frac{\text{PR}(\text{ref})}{F_{\text{led}}}$$

The **Pulse_lev (ideal)** is calculated using the following formula:

$$\text{Pulse_lev}(\text{ideal}) = \frac{230\text{V}}{V_{\text{mains}}} * \frac{20\text{A}}{I_{\text{max}}} * 435924$$

It is important to note that the formula for **Pulse_lev (corrected)** above should not be confused with the formula in the previous method of calibration for 'Defined Current and Calibration Time' method, where N_i and N_r are reversed.

Example

The reference meter has a pulse rate, which is 10,000 times greater than the pulse rate of the AS8168 CAL output. During a calibration cycle we measure 11,000 pulses between two CAL pulses. Therefore the ideal pulse-level has to be changed by a factor of $10,000/11,000 = 0.909$.

Calibration without On-Chip Programming

It is also possible to calibrate a kWh meter using the AS8168 by means of an external resistor network or trim-potentiometer. In this case, the parameters for the required pulse outputs are programmed into the device, along with the ideal value for **Pulse_lev** as defined in the formula above. A resistor network may then be used in the voltage divider for the voltage input setting, which is then trimmed until the measured pulse rate matches the ideal pulse rate.

In the case for kWh meter designs, which include a μ -controller and non-volatile memory, again, the parameters for the required pulse outputs are programmed into the device, along with the ideal value for **Pulse_lev** as defined in the formula above. The calibration may then be performed in the μ -controller.

Defining the Programmed Word

The AS8168 allows for all on-chip programmable functions to be reprogrammed a second time. It is important to always use the Bank '0' as the first programming option. This is necessary as once Bank '1' has been selected and this selection has been permanently 'Burned' into the AS8168 device, Bank '0' can no longer be selected.

When programming the AS8168, the Bank that is NOT selected should have all '0' values as the programmed values. Confirmation of this is shown in the example below, where Bank '0' has been selected for programming. All the programme bits of Bank '1' have been programmed as '0'.

Important: The value of Bit [0] must always be '1' when programming the AS8168, regardless of the memory bank being programmed. The Bits [69:68] are not used and are thus 'Don't Care' bits. The programmed value may be '1' or '0'.

An example of the word to be programmed to the AS8168 should look as follows:

Bit Number	Bit Value	Description
[69:68]	00	Not used bits
[67:66]	00	Bank 1: Gain
[65:64]	00	Bank 1: Anticreep threshold
[63:62]	00	Bank 1: F_mon
[61:60]	00	Bank 1: F_cal
[59:57]	000	Bank 1: F_led
[56:35]	0x000000	Bank 1: Pulse_lev
[34:33]	00	Bank 0: Gain = 4 (CT mode)
[32:31]	01	Bank 0: Anticreep threshold = 7.43mA
[30:29]	00	Bank 0: F_mon: 100 imp/kWh
[28:27]	10	Bank 0: F_cal: Fmon x 32
[26:24]	101	Bank 0: F_led: 3200 imp/kWh
[23:2]	0x06A6D4	Bank 0: Pulse_lev: 435924
[1]	0	Select Bank 0
[0]	1	Select programmed values

After selecting all PROM parameters as required a complete 70-bit word (including two overhead bits) is formed, which must be written to the PROM.

Testwrite

Testwrite means that the word to be programmed is simply written to an on-chip shift register so that the resulting behavior of the AS8168 device may be examined. Once the PROM word is confirmed correct, it may be burned into the device. i.e. Irreversibly written to the AS8168.

Until the data has been burned into the device, in other words, if only a Testwrite procedure has been performed, the data will be lost when the supply is removed from the AS8168 device.

Due to the respective on-chip processing it is required to testwrite the inverse of the word to be programmed. Continuing with the above example the word defined in the example should be as follows:

69	68	67	66	65	64	63	62	61	60	59	58	57	56	55	54	53	52	51
1	1	1	1	1	1	1	1	1	1	1	1	1	1	1	1	1	1	1
50	...	34	33	32	31	30	29	28	27	26	25	24	23	22	21	20	19	
1	...	1	1	1	0	1	1	0	1	0	1	0	1	1	1	0	0	
18	17	16	15	14	13	12	11	10	9	8	7	6	5	4	3	2	1	0
1	0	1	0	1	1	0	0	1	0	0	1	0	1	0	1	1	1	0

The Testwrite procedure is carried out as described in the following timing diagram:

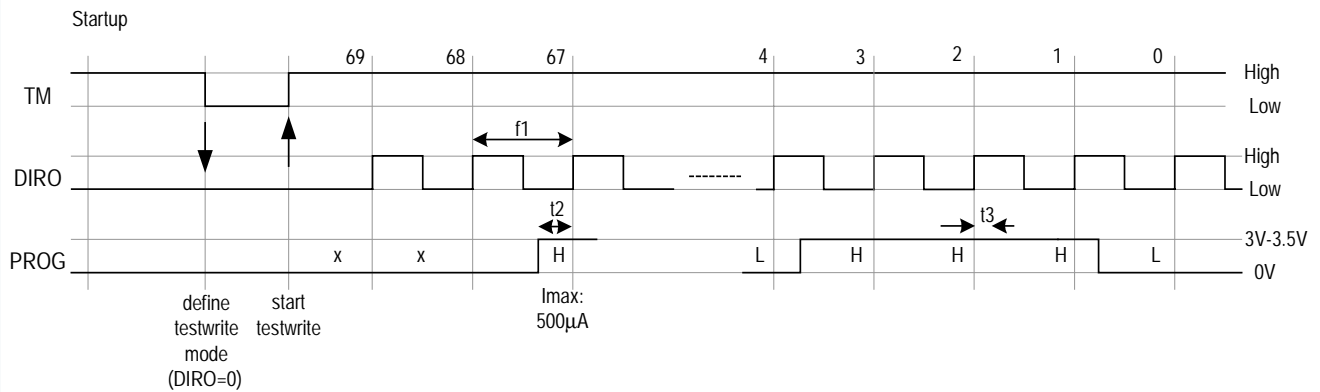

Note: High and Low refers to VDD and VSS respectively.

On the first falling TM edge the mode (Testwrite) is defined. On the next rising TM edge the procedure is started. Afterwards 70 clocks have to be sent to DIRO. As can be seen the logic level on PROG prior to the positive DIRO edges defines the state to be shifted into the internal register.

Important timing parameters are:

f1: Maximum frequency, must not exceed 50kHz

t2: Data setup time, minimum is 100ns

t3: Data storage time: the programmed bit is stored after approximately 20ns

Burn

The Burn procedure irreversibly writes data to the PROM. To do this, the 1s in the original word to be programmed must be burned.

Continuing with the above example, the defined word to be burned will be as follows:

69	68	67	66	65	64	63	62	61	60	59	58	57	56	55	54	53	52	51
0	0	0	0	0	0	0	0	0	0	0	0	0	0	0	0	0	0	0
50	...	34	33	32	31	30	29	28	27	26	25	24	23	22	21	20	19	
0	...	0	0	0	1	0	0	1	0	1	0	1	0	0	0	1	1	
18	17	16	15	14	13	12	11	10	9	8	7	6	5	4	3	2	1	0
0	1	0	1	0	0	1	1	0	1	1	0	1	0	1	0	0	0	1

The following timing diagram shows how the burn procedure is carried out:

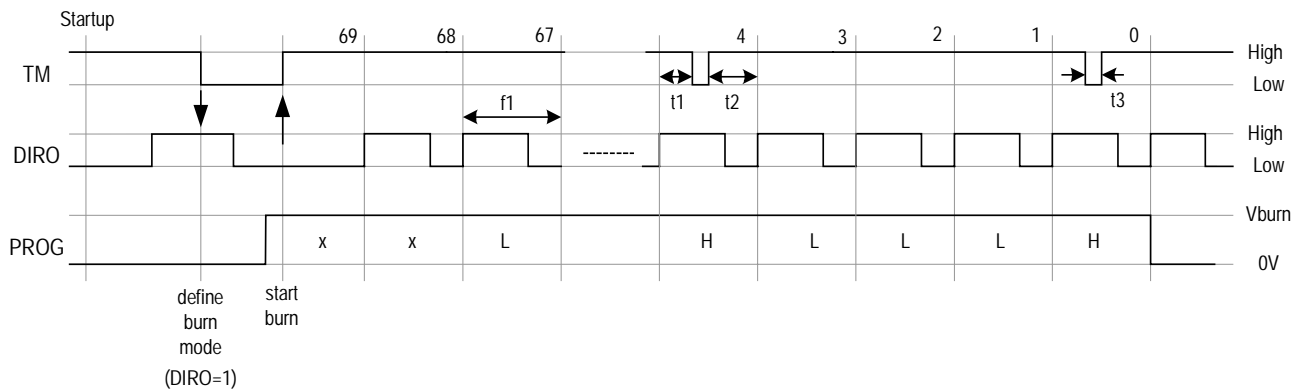

Note: High and Low refers to VDD and VSS respectively.

The first falling and rising edges on TM define the burn mode and starts it (as can be seen DIRO must be set to logic 'high' at the falling edge, but must be low at the rising edge). Then the first PROM cell is selected. After each rising clock edge on DIRO the next PROM cell is selected going from MSB to LSB. While one of the PROM cells is selected a defined (low-active) pulse on TM must be applied to "burn" the respective PROM cell, i.e. write a permanent logic-1 to it.

Important specifications are:

Tburn: Temperature during burn cycle: 25°C ± 10°C

Vburn: 7.50 ± 0.25V (at the AS8168 PROG pin)

f1: Maximum DIRO clock frequency is 100kHz

t1: The burn pulse must have a delay of at least 1µs after the previous positive DIRO clock edge

t2: After one burn pulse there must be a delay of at least 1µs before the next PROM cell is selected

t3: The burn pulse width is defined to be 1.0 ± 0.2µs. The rise and fall time of the burn pulses on TM must be less than 50ns.

After a burn cycle has been completed, a read cycle must be initiated so that the actual data is loaded. (After "burn" the data in the internal register is inverted!)

Read

The conditions for 'burn' are specified very tightly. In order to be certain that the 'burn' process was successful this process has to be verified. There are 2 modes of readout, a digital readout and analog readout.

Digital readout uses the threshold of the comparator internal to the AS8168. Thus, the result, which can be observed on the CAL pin, is the same as that used internally by the AS8168. Digital readout does NOT allow the quality of the 'burn' to be evaluated.

Analog readout does allow for the verification of the analog value of the zener diodes. With analog readout, the quality of the 'burn' can be verified.

In order to verify the 'burn' process, an 'analog readout' of the zener diodes voltages has to be performed as the last step after calibration. This can be done during the 'read' process, which may be started during calibration mode. The goal is to verify that burned diodes show a voltage level of not more than 0.5V during the analog readout and the 'unburned' diodes a voltage level of more than 2.4V.

Digital Readout

The AS8168 offers the customer the ability to read the PROM data. For example, it may be necessary to examine if a device has been calibrated already and what value is correctly stored in the PROM. For the read mode the same two digital inputs (TM and DIRO) are used as for 'testwrite' and 'burn'. As can be seen in the following timing diagram the read mode is selected by setting DIRO=1 while there is a rising edge on TM. (This assumes that one of the 3 modes has been completed or the chip has just been powered up, i.e. the chip expects to enter a new mode.)

The following timing diagram shows the digital readout of the zener diodes:

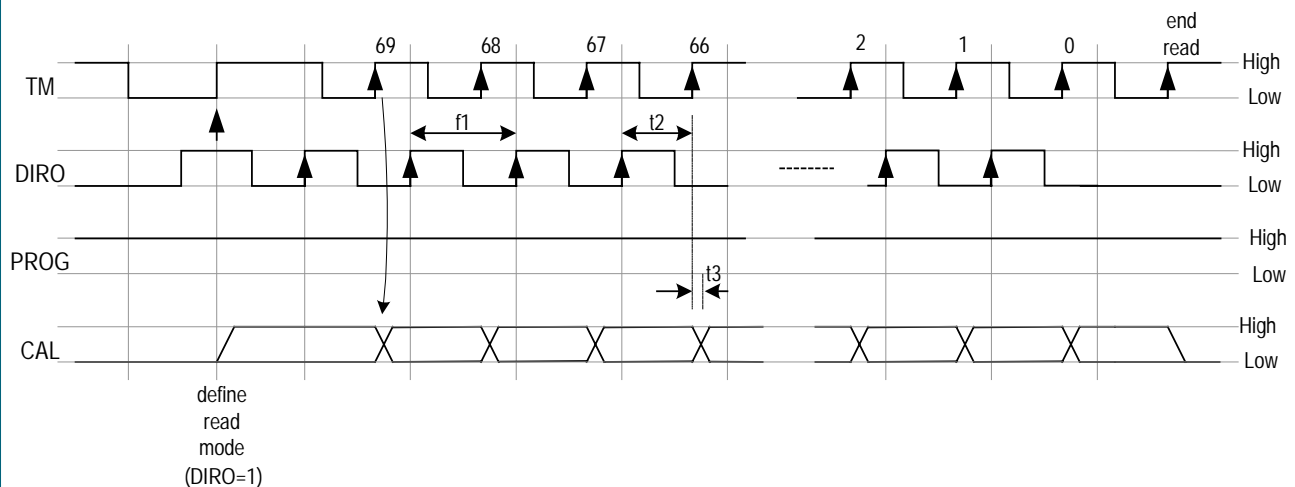

Note:

1. High and Low refers to VDD and VSS respectively.
2. In this case, the term 'digital' means that there is an on-chip comparator, which decides on the values of the bits, 0 or 1, relative to a certain threshold; it neither guarantees the burned zener diodes voltage level to be below 0.5V (ZV_B) nor a value for unburned zener diodes of higher than 2.4V (ZV_{UB}) as shown in the Operating Conditions.

After starting read mode with each rising edge on DIRO one of the PROM cells is selected. Its content is stored in a separate internal flip-flop, the output of which can be watched on pin CAL (only during read!). With one additional rising edge on TM the read mode is left and pin CAL shows the normal pulse output again.

Important: The bits displayed on CAL are the inverse of the PROM contents, i.e. they have to be inverted to match with the previous PROM contents table.

Important timings are:

f1: Maximum read frequency, for reliable reading this should not be higher than 100kHz.

t2: Delay between the two rising edges: >100ns

t3: Depending on the loading on pin CAL the delay between rising edge on TM and change of data on CAL may vary. A typical value is 50ns.

Analog Readout

The analog readout can be performed by disconnecting the PROG pin from the calibration board and starting a 'read' sequence. At specific points in time the voltage level on the PROG pin must be sampled. These time points are shown in the following timing diagram.

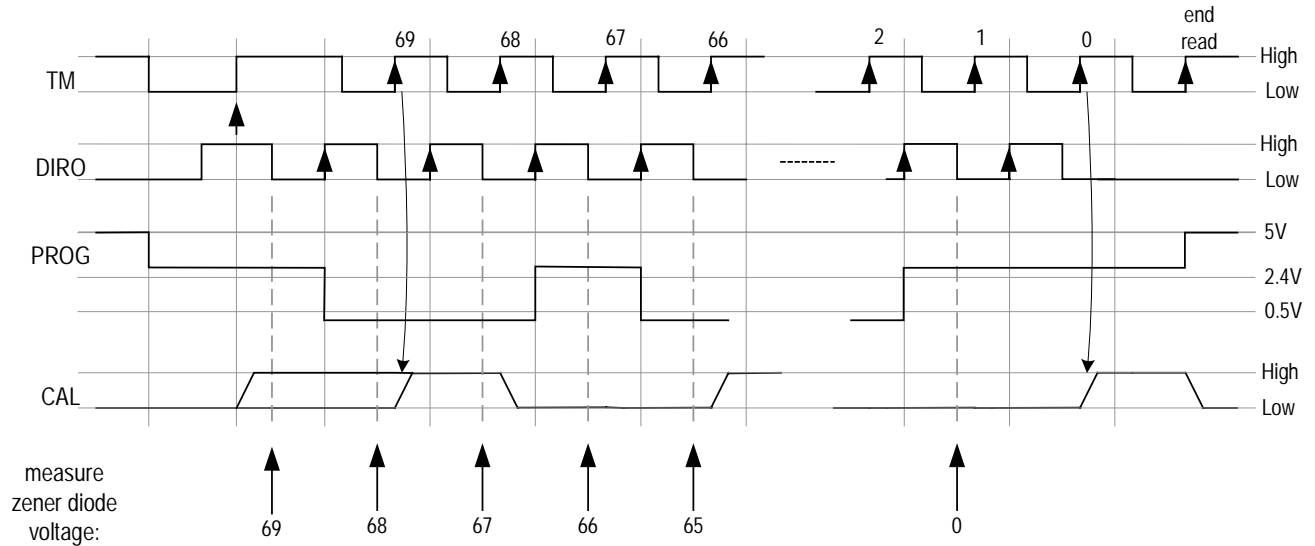

The numbers at the bottom of this timing diagram indicate the sample points of the bits in the PROM table, at which the zener diode voltage level can be measured and compared against the limits for burned and unburned zener diodes.

In general this readout is most important, when a new calibration system is installed. Variations on the burn voltage or even the length of the cable connected to the AS8168 PROG pin may have an influence on the quality of the burn process.

Application Circuit

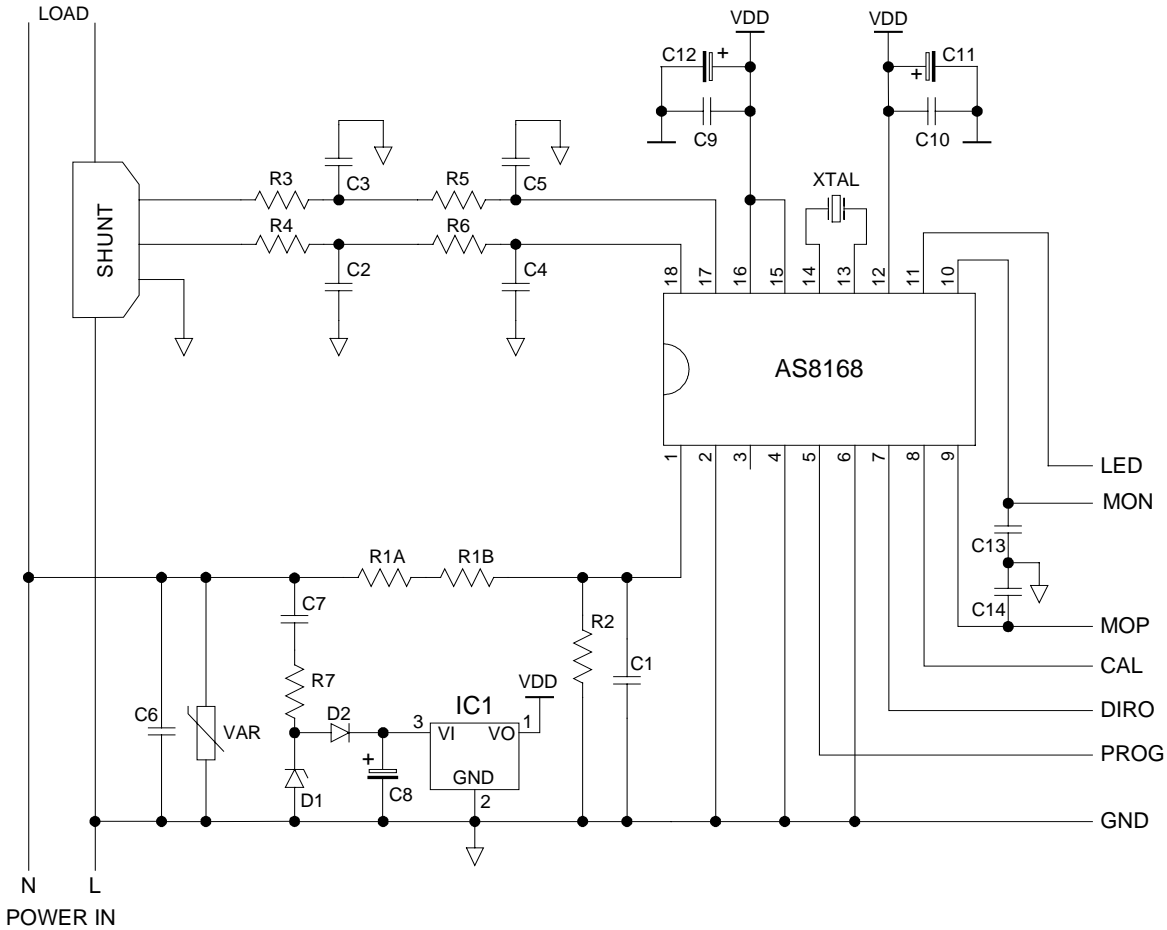

Note:

1. There must be proper ground connection between the calibration hardware and the meter under calibration during 'Calibration Mode'. This ensures that the programming procedure is not effected by spurious signals. Such spurious signals could originate from load switching during calibration.
2. When using a low resistance shunt for current sensing, a small parasitic inductance introduced by the shunt can have negative effects on the measurement accuracy. The filters on the current inputs designated by the components R5, C5 and R6, C4 provide a cancellation effect on the parasitic shunt inductance. The filters assume a typical inductance of between 1nH and 2nH.

Parts List

Designation	Value	Unit	Description
AS8168			Single Phase Average Energy Metering IC
Rshunt	300	μOhm	Precision Resistor, ±5%
R1A	820	kOhm	Resistor, 0.6W, ±10%
R1B	750	kOhm	Resistor, 0.6W, ±10%
R2	820	Ohm	SMD Resistor, ±1%
R3, R4, R5, R6	680	Ohm	SMD Resistor, ±1%
R7	470	Ohm	Resistor, 1W, ±5%
C1	68	nF	SMD Capacitor, ±5%
C2, C3, C4, C5	33	nF	SMD Capacitor, ±5%
C6	10	nF	Capacitor (Polypropylene), 1000VDC/250VAC, ±10%
C7	470	nF	Capacitor (Polypropylene), 1000VDC/250VAC, ±10%
C8	470	μF	Capacitor (Electrolytic), ±20%
C9, C10	100	nF	SMD Capacitor, ±5%
C11	10	μF	Capacitor (Electrolytic) , ±10%
C12	220	μF	Capacitor (Electrolytic) , ±20%
C13, C14	100	nF	SMD Capacitor, ±10%
IC1			LM78L05 Voltage Regulator, ±5%
XTAL	3.579545	MHz	Quartz Crystal or Ceramic Resonator, 20ppm/K
D1			BZV85-C15 Zener Diode, 1.3W, 15V, ±5%
D2			1N4007 Diode
VAR S20K275			Varistor, $V_{RMS} = 275V$, $V_{DC} = 350V$

Electrical Characteristics

Absolute Maximum Ratings *

Parameter	Symbol	Min	Max	Unit	Note
DC Supply Voltage	VDD	-0.3	7.0	V	
Input Pin Voltage	V _{in}	-0.3	VDD + 0.3	V	
Input Current on any Pin	I _{in}	-100	+100	mA	25°C
Storage Temperature	T _{strg}	-65	+150	°C	
Humidity Noncondensing	H	5	85	%	
Electrostatic Discharge			1000	V	1)
Lead Temperature				°C	2)

1) MIL STD883 method 3015.7 'Human Body Model' (R = 1.5kΩ; C = 100pF)

2) IEC61760-1, soldering conditions

* Stresses above those listed may cause permanent damage to the device. This is a stress rating only and functional operation of the device at these or any other conditions above those indicated in the operational sections of this specification is not implied. Exposure to absolute maximum rating conditions for extended periods may affect device reliability (eq. hot carrier degradation).

Operating Conditions

Parameter	Symbol	Min	Typ	Max	Unit	Note
Positive Analog Supply Voltage	AVDD	4.5	5.0	5.5	V	Referred to AVSS Typical ±10%
Negative Analog Supply Voltage	AVSS		0		V	
Difference of Supply	A - D	-0.1		0.1	V	AVDD – DVDD AVSS – DVSS
Positive Digital Supply Voltage	DVDD	4.5	5.0	5.5	V	Referred to DVSS Typical ±10%
Negative Digital Supply Voltage	DVSS		0		V	
Supply Current	I _{supp}			4	mA	
Ambient Temperature	T _{amb}	-40	25	85	°C	
Measured Frequency	f _{meas}	45		65	Hz	
System Clock Frequency	f _{clk}	3.56	3.58	3.60	MHz	Variations result in gain errors which are calibrated out
Measurement Bandwidth	BW		870		Hz	
PROM Zener Voltage Unburned	ZV _{UB}	2.4			V	Measured during analog readout
PROM Zener Voltage Burned	ZV _B			0.5	V	Measured during analog readout
Output Pulse Stability	OPst			0.2	%	1)

1) Difference between largest and smallest error of 20 successive error samples.

Test Conditions: Reference meter: 10,000 x MUT meter constant; measured at 5 % I_B, I_B and I_{max}; meter constant 3200imp/kWh

DC Characteristics

Digital Input with Pull-down (TM)

Parameter	Min	Max	Note
Vih	0.8 * VDD		
Vil		0.2 * VDD	
Iih	30µA	160µA	DI, cmos w/pull-down (1)
Iil	NA	NA	DI, cmos w/pull-down

1) Iih tested at VDD = 5.5V and Vin = 5.5V

Digital Input with Pull-up (DIRI)

Parameter	Min	Max	Note
Vih	0.8 * VDD		
Vil		0.2 * VDD	
Iih	NA	NA	DI, cmos w/pull-up (2)
Iil	30µA	160µA	DI, cmos w/pull-up

2) Iil tested at VDD = 5.5V and Vin = 0V

Digital Input/Output with Pull-down (DIRO, CAL)

Parameter	Min	Max	Note
Input			
Vih	0.8 * VDD		
Vil		0.2 * VDD	
Iih	30µA	160µA	(1)
Iil	NA	NA	DI, cmos w/pull-down
Output			
Voh	4.0V		Ioh = -4mA
Vol		0.4V	Iol = 4mA

1) Iih is tested at VDD = 5.5V and Vin = 5.5V

Digital Output (MON, MOP, LED)

Parameter	Min	Max	Note
Voh	4.0V		Ioh = -10mA
Vol		0.4V	Iol = 10mA

Package Dimensions

PDIP-18

(ALL DIMENSIONS IN INCH)

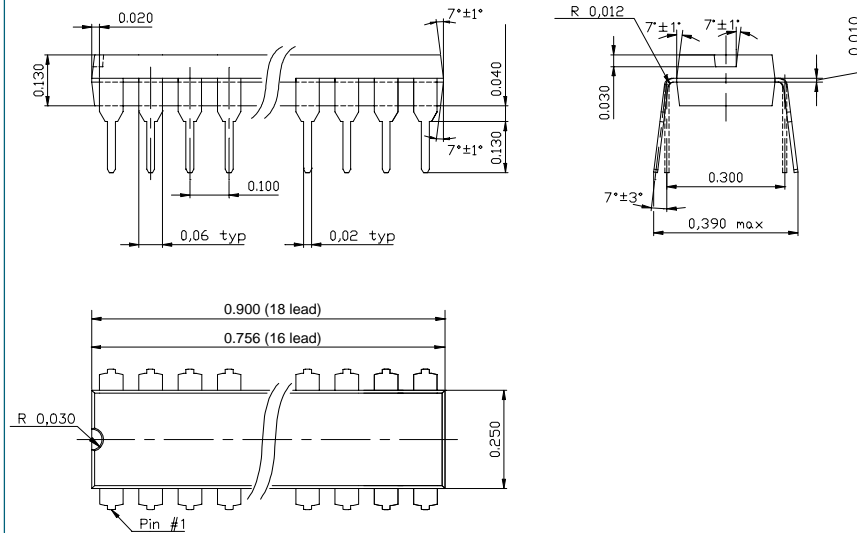

SOIC-18

(ALL DIMENSIONS IN INCH)

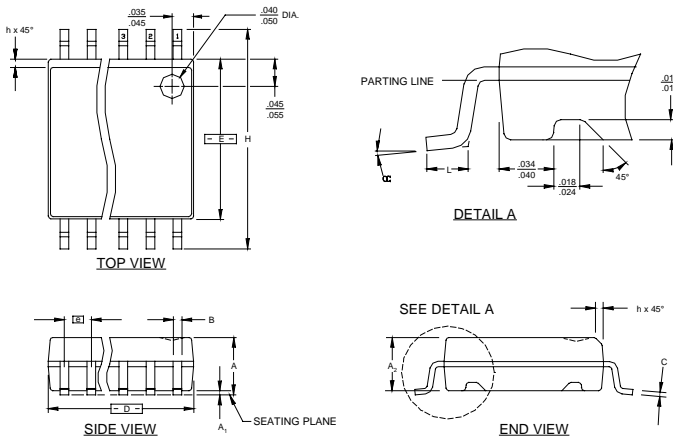

SYMBOL	COMMON DIMENSIONS			NOTE
	MIN	NOM	MAX	
A	.097	.101	.104	
A ₁	.0050	.009	.0115	
A ₂	.090	.092	.094	
B	.014	.016	.019	
C	.0091	.010	.0125	
D	SEE VARIATIONS			3
E	.292	.296	.299	
e	.050			
H	.400	.406	.410	
h	.010	.013	.016	
L	.024	.032	.040	
N	SEE VARIATIONS			5
	0°	5°	8°	
X	.085	.093	.100	
VARIATIONS				NOTE 5 (N)
NOTE 3 (D)				
SYMBOL	MIN	NOM	MAX	
AA	.402	.407	.412	16
AB	.451	.456	.461	18
AC	.500	.505	.510	20
AD	.602	.607	.612	24
AE	.701	.706	.711	28

Ordering Information

Part Number	Package
AS8168D18	DIP-18
AS8168S18	SOIC-18

Copyright

Copyright © 1997-2004, austriamicrosystems AG, Schloss Premstaetten, 8141 Unterpremstaetten, Austria - Europe. Trademarks Registered ®. All rights reserved. The material herein may not be reproduced, adapted, merged, translated, stored, or used without the prior written consent of the copyright owner.

Disclaimer

Devices sold by austriamicrosystems AG are covered by the warranty and patent indemnification provisions appearing in its Terms of Sale. austriamicrosystems AG makes no warranty, express, statutory, implied, or by description regarding the information set forth herein or regarding the freedom of the described devices from patent infringement. austriamicrosystems AG reserves the right to change specifications and prices at any time and without notice. Therefore, prior to designing this product into a system, it is necessary to check with austriamicrosystems AG for current information. This product is intended for use in normal commercial applications. Applications requiring extended temperature range, unusual environmental requirements, or high reliability applications, such as military, medical life-support or life-sustaining equipment are specifically not recommended without additional processing by austriamicrosystems AG for each application.

The information furnished here by austriamicrosystems AG is believed to be correct and accurate. However, austriamicrosystems AG shall not be liable to recipient or any third party for any damages, including but not limited to personal injury, property damage, loss of profits, loss of use, interruption of business or indirect, special, incidental or consequential damages, of any kind, in connection with or arising out of the furnishing, performance or use of the technical data herein. NO obligation or liability to recipient or any third party shall arise or flow out of austriamicrosystems AG rendering of technical or other services.

Note:

Contact

Headquarters

austriamicrosystems AG
 A 8141 Schloss Premstaetten, Austria
 Phone: +43 3136 500 0
 Fax: +43 3136 525 01
info@austriamicrosystems.com

austriamicrosystems AG
 Suite 915, No. 1,
 Suhua Road,
 Suzhou Industrial Park,
 PR **China** 215021
 Phone: +86 512 6762 2590
 (6762 2593)
 Fax: +86 512 6762 2594

Sales Offices

austriamicrosystems Germany GmbH
 Tegernseer Landstrasse 85
 D 81539 München, **Germany**
 Phone: +49 89 69 36 43 0
 Fax : +49 89 69 36 43 66

austriamicrosystems AG
 Suite 811, Tsimshatsui Centre,
 East Wing, 66 Mody Road,
 Tsim Sha Tsui East,
 Kowloon, **Hong Kong**
 Phone: +852 2268 6899
 Fax: +852 2268 6799

austriamicrosystems AG
 Klaavuntie 9 G 55
 FI 00910 Helsinki, **Finland**
 Phone: +358 9 72688 170
 Fax: +358 9 72688 171

austriamicrosystems Japan, AG
 AIOS Gotanda Annex 5th Fl.,
 1-7-11,
 Higashi-Gotanda,
 Shinagawa-ku,
 Tokyo 141-0022, **Japan**
 Phone: +81 3 5792 4975
 Fax : +81 3 5792 4976

austriamicrosystems France S.A.R.L.
 124, Avenue de Paris
 F 94300 Vincennes, **France**
 Phone: +33 1 43 74 00 90
 Fax : +33 1 43 74 20 98

austriamicrosystems AG
 #805, Dong Kyung Bldg., 824-19,
 Yeok Sam Dong,
 Kang Nam Gu, Seoul
Korea 135-080
 Phones: +82 2 557 8776
 Fax: +82 2 569 9823

austriamicrosystems AG
 Bivägen 3B
 S 19163 Sollentuna, **Sweden**
 Phone: +46 8 6231 710

austriamicrosystems AG
 83, Clemenceau Avenue,
 #02-01, UE Square,
Singapore 239920
 Phone: +65 6 830 8305
 Fax: +65 6 234 3120

austriamicrosystems Switzerland AG
 Rietstrasse 4
 CH 8640 Rapperswil, **Switzerland**
 Phone: +41 55 220 9008
 Fax : +41 55 220 9001

austriamicrosystems AG
 2nd Floor,
 No. 31, Sec. 2
 Nam-Chang Road,
 Taipei, **Taiwan**
 Phone: +886 2 2395 6600 227
 Fax: +886 2 2395 7330

austriamicrosystems AG
 88, Barkham Ride,
 Finchampstead, Wokingham,
 Berkshire RG40 4ET, **United Kingdom**
 Phone: +44 118 973 1797
 Fax: +44 118 973 5117

austriamicrosystems USA, Inc.
 8601 Six Forks Road
 Suite 400
 Raleigh, NC 27615, **USA**
 Phone: +1 919 676 5292
 Fax : +1 509 696 2713