

3-Channel Power Supply Supervisor

Features

- Over Voltage Protection and Lock Out for 3.3 V, 5 V, and 12 V
- Under Voltage Protection and Lock Out for 3.3 V and 5 V
- Fault Protection Output with Open Drain Output Stage
- Open Drain Power Good Output Signal for Power Good Input, 3.3 V and 5 V
- 300 ms Power Good Delay
- 2.36ms $\overline{\text{PSON}}$ Control to $\overline{\text{FPO}}$ Turn Off Delay
- 38 ms Control Debounce
- 75 ms Delay for 3.3V and 5V Under Voltage Protection
- 73 μs Width Noise Deglitches
- Wide Power Supply Voltage Range from 4 V to 15 V

General Description

The APW1680 is designed to minimize the external components of personal-computer switching power supply systems. It provides protection circuits, power good indicator, fault protection output FPO and control.

OVP (over voltage protection) monitors 3.3V, 5 V, and 12 V (12 V OV detects via V_{CC} terminal). UVP (under voltage protection) monitors 3.3V and 5V. When an OV or UV condition is detected, the PGO (power good output) is set to low and FPO is latched to high. $\overline{\text{PSON}}$ from low to high resets the protection latch.

Power good feature monitors PGI, 3.3V and 5V under voltages, and issues a power good signal when they are ready.

Applications

- PC Switching Power Supply

Pin Description

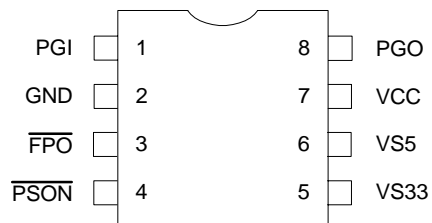

Ordering Information

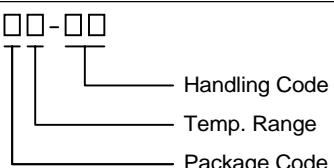
<p>APW1680 $\square\square-\square\square$</p> <div style="margin-left: 20px;">  </div>	<p>Package Code J : DIP - 8 Temp. Range C : 0 to 70 °C Handling Code TU : Tube</p>
--	--

ANPEC reserves the right to make changes to improve reliability or manufacturability without notice, and advise customers to obtain the latest version of relevant information to verify before placing orders.

Pin Function Description

Terminal Name	NO.	I/O	Terminal Function Description
V_{S33}	5	I	3.3 V over/under voltage protection input pin
V_{S5}	6	I	5 V over/under voltage protection input pin
GND	2		Ground
\overline{FPO}	3	O	Inverted fault protection output, open drain output stage
PGI	1	I	Power good input signal pin
PGO	8	O	Power good output signal pin, open drain output stage
\overline{PSON}	4	I	ON/OFF control input pin
V_{CC}	7	I	Supply voltage/12 V over voltage protection input pin

Thermal Characteristics

Symbol	Parameter	Value	Unit
R_{THJA}	Thermal Resistance from Junction to Ambient in Free Air DIP-8	129	K/W

Electrical Characteristics $V_{CC}=5V, T_A=25^\circ C$ (unless otherwise noted)

Symbol	Parameter	Test Conditions	APW1680			Unit
			Min.	Typ.	Max.	
Over Voltage Protection						
	Over Voltage Threshold	V_{S33}	3.7	3.9	4.1	V
		V_{S5}	5.7	6.1	6.5	
		V_{CC}	13.3	13.8	14.3	
I_{LKG}	Leakage Current (\overline{FPO})	$V(\overline{FPO})=5V$			5	μA
V_{OL}	Low Level Output Voltage (\overline{FPO})	$I_{SINK}=10mA$			0.3	V
		$I_{SINK}=30mA$			0.7	
V_{OH}	\overline{FPO} Pin Pull High Voltage				15	V
PGI and PGO						
	Input Threshold Voltage (PGI)		1.14	1.19	1.24	V
	Under Voltage threshold	V_{S33}	2.55	2.7	2.83	V
		V_{S5}	4.1	4.3	4.5	
	Under Voltage Protection Delay Time (3.3V and 5V)		49	75	114	ms

Electrical Characteristics (Cont.)

Symbol	Parameter	Test Conditions	APW1680			Unit
			Min.	Typ.	Max.	
I_{LKG}	Leakage Current (PGO)	PGO=5V			5	μA
V_{OL}	Low Level Output Voltage (PGO)	Sink Current = 10mA			0.4	V
V_{OH}	PGO Pin Pull High Voltage				7	V
PSON Control						
	Input Pull-Up Current	$\overline{PSON} = 0V$		150		μA
	High-Level Input Voltage		2.4			V
	Low-Level Input Voltage				1.2	V
Total Device						
V_{CC}	Supply Voltage		4		15	V
I_{CC}	Supply Current	$\overline{PSON} = 5V$			1	mA
Switching Characteristics						
t_{d1}	Delay time (PGI to PGO)		200	300	450	ms
t_b	Debounce Time (\overline{PSON})		24	38	57	ms
T_{dq}	Noise Deglitch Time		47	73	110	μs
t_{d2}	Delay Time (\overline{PSON} to \overline{FPO})		$t_b+1.1$	$t_b+2.36$	t_b+4	ms

Typical Application Circuit

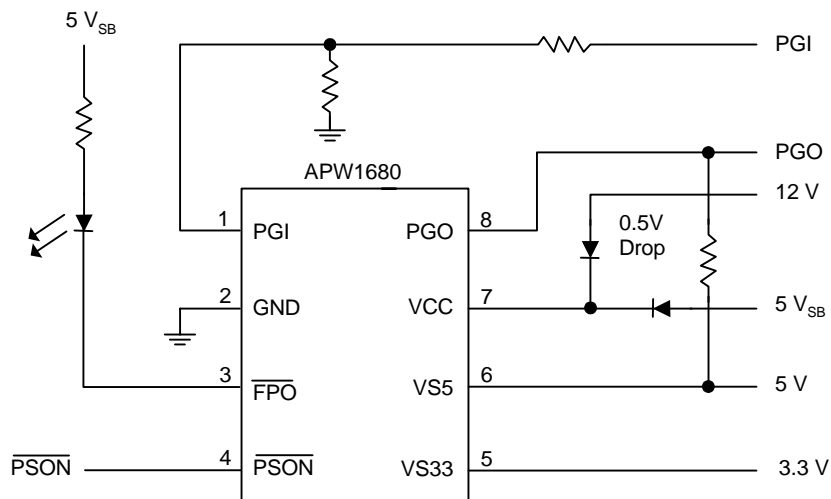

Timing Chart

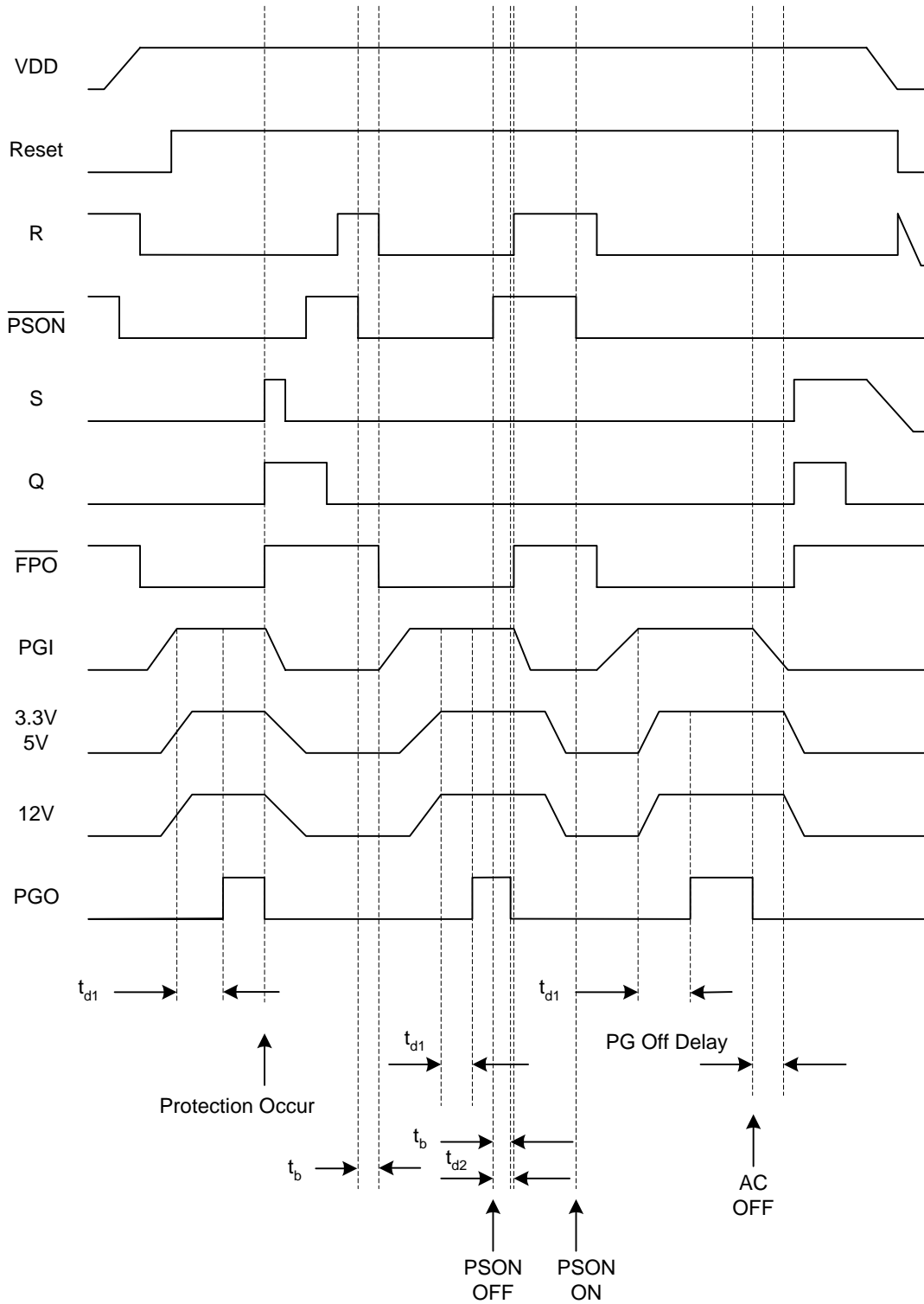

Packaging Information

PDIP-8 pin (Reference JEDEC Registration MS-001)

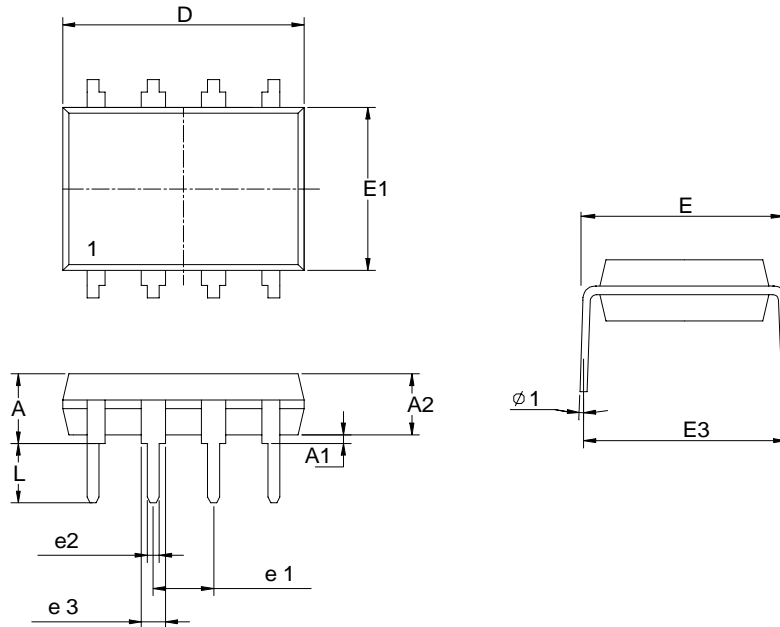

Dim	Millimeters		Inches	
	Min.	Max.	Min.	Max.
A		5.33		0.210
A1	0.38		0.015	
A2	2.92	3.68	0.115	0.145
D	9.02	10.16	0.355	0.400
e1	2.54BSC		0.100BSC	
e2	0.36	0.56	0.014	0.022
e3	1.14	1.78	0.045	0.070
E	7.62 BSC		0.300 BSC	
E1	6.10	7.11	0.240	0.280
E3		10.92		0.430
L	2.92	3.81	0.115	0.150
φ 1	0°	15°	0°	15°

Customer Service

Anpec Electronics Corp.

Head Office :

5F, No. 2 Li-Hsin Road, SBIP,
Hsin-Chu, Taiwan, R.O.C.
Tel : 886-3-5642000
Fax : 886-3-5642050

Taipei Branch :

7F, No. 137, Lane 235, Pac Chiao Rd.,
Hsin Tien City, Taipei Hsien, Taiwan, R. O. C.
Tel : 886-2-89191368
Fax : 886-2-89191369