

HIGH RELIABILITY HYBRID DC-DC CONVERTERS

DESCRIPTION

The DVGF+ series of high reliability DC-DC converters is operable over the full military (-55 °C to +125 °C) temperature range with no power derating. Unique to the DVGF+ series is a fault tolerant magnetic feedback circuit. Operating at a nominal fixed frequency of 325 kHz per stage, these regulated, isolated units utilize well-controlled undervoltage lockout circuitry to eliminate slow start-up problems.

These converters are designed and manufactured in a facility qualified to ISO9001 and certified to MIL-PRF-38534 and MIL-STD-883.

This product may incorporate one or more of the following U.S. patents:

5,784,266
5,790,389
5,963,438
5,999,433
6,005,780
6,084,792
6,118,673

FEATURES

- High Reliability
- Very Low Output Noise
- Wide Input Voltage Range: 15 to 50 Volts per MIL-STD-704
- Up to 12.5 Watts Output Power
- Fault Tolerant Magnetic Feedback Circuit
- NO Use of Optoisolators
- Undervoltage Lockout
- Indefinite Short Circuit Protection
- Current Limit Protection
- Industry Standard Pinout
- High Input Transient Voltage: 80 Volts for 1 sec per MIL-STD-704A
- Precision Projection Welded Hermetic Package
- High Power Density: > 23 W/in³
- Custom Versions Available
- Additional Environmental Screening Available
- Meets MIL-STD-461C and MIL-STD-461D EMC Requirements When Used With a DVMH28 EMI Filter
- Flanged and Non-flanged Versions Available.
- MIL-PRF-38534 Element Evaluated Components

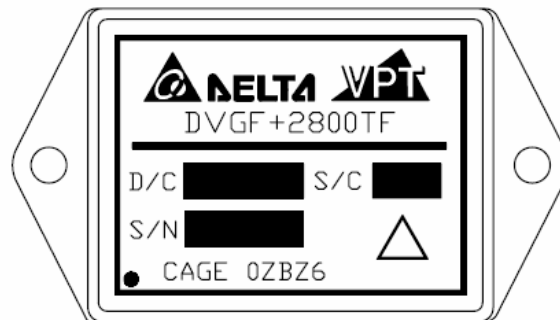

Figure 1 – DVGF+2800T / DVGF+2800TF DC-DC Converter
(Not To Scale)

SPECIFICATIONS ($T_{CASE} = -55^{\circ}C$ to $+125^{\circ}C$, $V_{IN} = +28V \pm 5\%$, Full Load⁵, Unless Otherwise Specified)

ABSOLUTE MAXIMUM RATINGS

Input Voltage (Continuous)	50 V _{DC}	Junction Temperature Rise to Case	+15°C
Input Voltage (Transient, 1 second)	80 Volts	Storage Temperature	-65°C to +150°C
Output Power	12.5 Watts	Lead Solder Temperature (10 seconds)	270°C
Power Dissipation (Full Load, $T_{CASE} = +125^{\circ}C$)	6.5 Watts	Weight (Maximum) (Un-Flanged / Flanged)	(26 / 29) Grams

Parameter	Conditions	DVGF+283R312T			DVGF+283R315T			Units	
		Min	Typ	Max	Min	Typ	Max		
STATIC									
INPUT Voltage	Continuous	15	28	50	15	28	50	V	
	Transient, 1 sec ⁴	-	-	80	-	-	80	V	
Current	Inhibited	-	3.5	5.0	-	3.5	5.0	mA	
	No Load	-	-	50	-	-	50	mA	
Ripple Current	Full Load ⁵ , 20Hz to 10MHz	-	-	50	-	-	50	mA _{p-p}	
Inhibit Pin Input ⁴		0	-	1.5	0	-	1.5	V	
Inhibit Pin Open Circuit Voltage ⁴		13	15	17	13	15	17	V	
UVLO Turn On		10.5	-	14.5	10.5	-	14.5	V	
UVLO Turn Off ⁴		9	-	13	9	-	13	V	
OUTPUT Voltage	V _{MAIN}	T _{CASE} = 25°C	3.267	3.30	3.333	3.267	3.30	3.333	V
	+V _{AUX}		11.88	12.0	12.12	14.85	15.0	15.15	V
	-V _{AUX}		-12.24	-12.0	-11.76	-15.30	-15.0	-14.70	V
	V _{MAIN}	T _{CASE} = -55°C to +125°C	3.25	3.30	3.35	3.25	3.30	3.35	V
	+V _{AUX}		11.64	12.0	12.36	14.55	15.0	15.45	V
	-V _{AUX}		-12.48	-12.0	-11.52	-15.60	-15.0	-14.40	V
Power ⁴	Total		0	-	12.5	0	-	12.5	W
	V _{MAIN}		0	-	5	0	-	5	W
	±V _{AUX} ⁶		0	-	7.5	0	-	7.5	W
Current ³	V _{MAIN}		0	-	1.5	0	-	1.5	A
	±V _{AUX}	Either Output ⁶	0	-	0.44	0	-	0.35	A
Ripple Voltage	V _{MAIN}	Full Load ⁵ , 20Hz to 10MHz	-	40	50	-	40	50	mV _{p-p}
	±V _{AUX}		-	60	80	-	60	80	mV _{p-p}
Line Regulation	V _{MAIN}	V _{IN} = 15V to 50V	-	10	20	-	10	20	mV
	±V _{AUX}		-	15	50	-	15	50	mV
Load Regulation	V _{MAIN}	No Load to Full Load ^{5,8}	-	5	50	-	5	50	mV
	+V _{AUX}		-	10	50	-	10	50	mV
	-V _{AUX}		-	20	200	-	20	200	mV
Cross Regulation	±V _{AUX}	+V _{OUT} = 30%, -V _{OUT} = 70% +V _{OUT} = 70%, -V _{OUT} = 30%	-	-	450	-	-	450	mV
EFFICIENCY		Full Load ⁵	73	75	-	73	75	-	%
LOAD FAULT POWER DISSIPATION		Overload ⁴	-	-	7.5	-	-	7.5	W
		Short Circuit	-	-	7.5	-	-	7.5	W
CAPACITIVE LOAD ⁴			-	-	500	-	-	500	μF
SWITCHING FREQUENCY			550	650	700	550	650	700	kHz
SYNCHRONIZATION FREQUENCY ⁷			700	750	800	700	750	800	kHz
ISOLATION		500 V _{DC} , T _{CASE} = 25°C	100	-	-	100	-	-	MΩ
MTBF (MIL-HDBK-217F)		AIF @ T _C = 55°C	-	350	-	-	350	-	kHrs

SPECIFICATIONS ($T_{CASE} = -55^{\circ}\text{C}$ to $+125^{\circ}\text{C}$, $V_{IN} = +28\text{V} \pm 5\%$, Full Load⁵, Unless Otherwise Specified)

ABSOLUTE MAXIMUM RATINGS

Input Voltage (Continuous)	50 V _{DC}	Junction Temperature Rise to Case	+15°C
Input Voltage (Transient, 1 second)	80 Volts	Storage Temperature	-65°C to +150°C
Output Power	12.5 Watts	Lead Solder Temperature (10 seconds)	270°C
Power Dissipation (Full Load, $T_{CASE} = +125^{\circ}\text{C}$)	6.5 Watts	Weight (Maximum) (Un-Flanged / Flanged)	(26 / 29) Grams

Parameter	Conditions	DVGF+283R312T			DVGF+283R315T			Units	
		Min	Typ	Max	Min	Typ	Max		
DYNAMIC									
Load Step Output Transient	V _{MAIN}	Half Load to Full Load	-	200	400	-	200	400	mV _{PK}
	±V _{AUX}		-	400	500	-	400	500	mV _{PK}
Load Step Recovery ²	V _{MAIN}		-	450	650	-	450	650	μSec
	±V _{AUX}		-	300	350	-	300	350	μSec
Line Step Output Transient ⁴	V _{MAIN}	V _{IN} = 15V to 50V	-	50	150	-	50	150	mV _{PK}
	±V _{AUX}		-	150	250	-	150	250	mV _{PK}
Line Step Recovery ^{2,4}	V _{MAIN}		-	100	200	-	100	200	μSec
	±V _{AUX}		-	100	300	-	100	300	μSec
Turn On Delay			-	-	17	-	-	17	mSec
Turn On Overshoot	V _{MAIN}	V _{IN} = 0V to 28V	-	-	15	-	-	15	mV _{PK}
	±V _{AUX}		-	-	50	-	-	50	mV _{PK}

- Notes:
1. This note intentionally not used.
 2. Time for output voltage to settle within 1% of its nominal value.
 3. Derate linearly to 0 at 135°C.
 4. Verified by qualification testing.
 5. 5W on V_{MAIN} and 7.5W on ±V_{AUX}.
 6. Up to 70% of the total auxiliary power or current can be drawn from either of the auxiliary outputs.
 7. Synchronization is TTL signal with V_{SYNC MAX} = 6V.
 8. -V_{AUX} is 5% Load to Full Load at -55°C.

BLOCK DIAGRAM

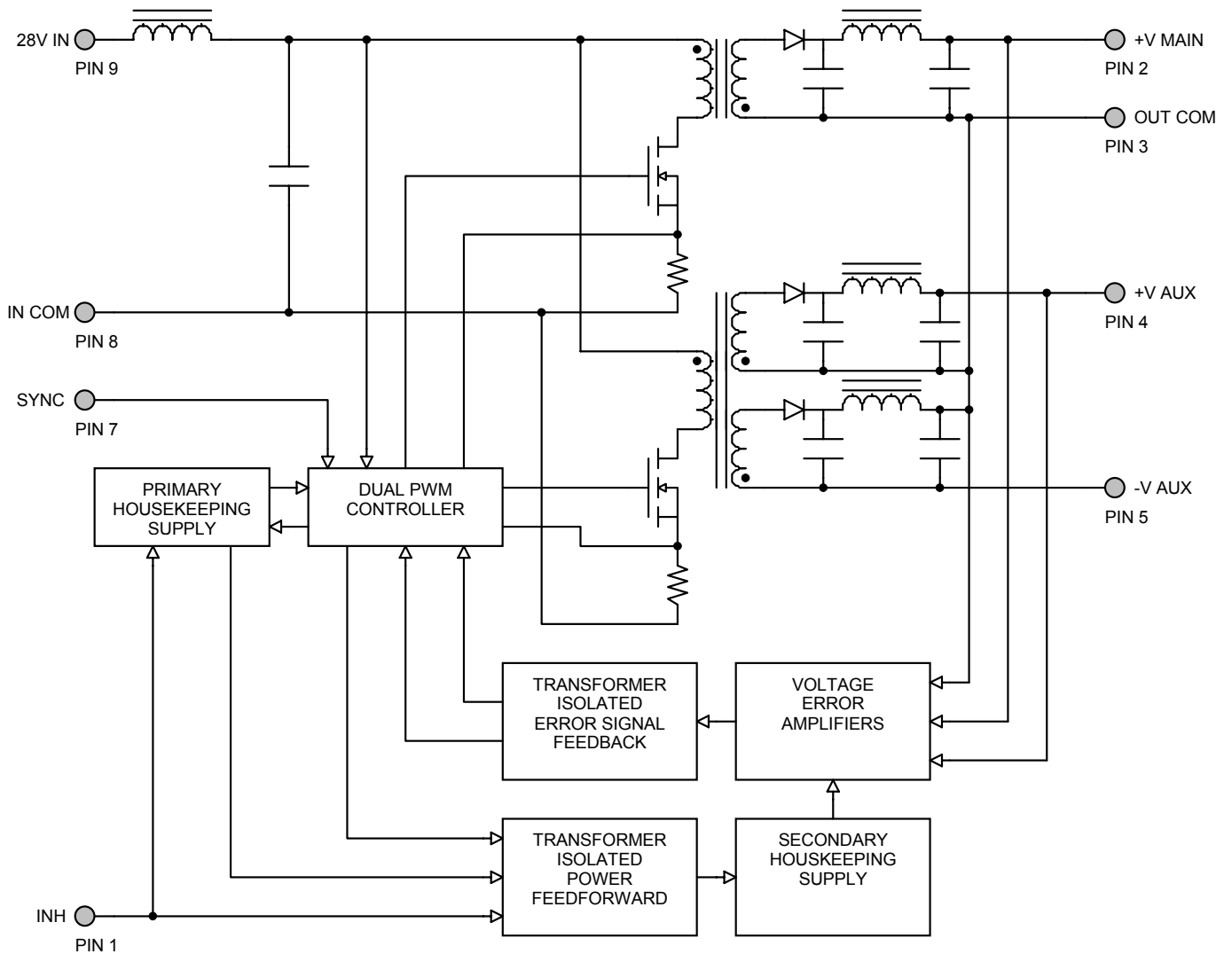

Figure 2

CONNECTION DIAGRAM

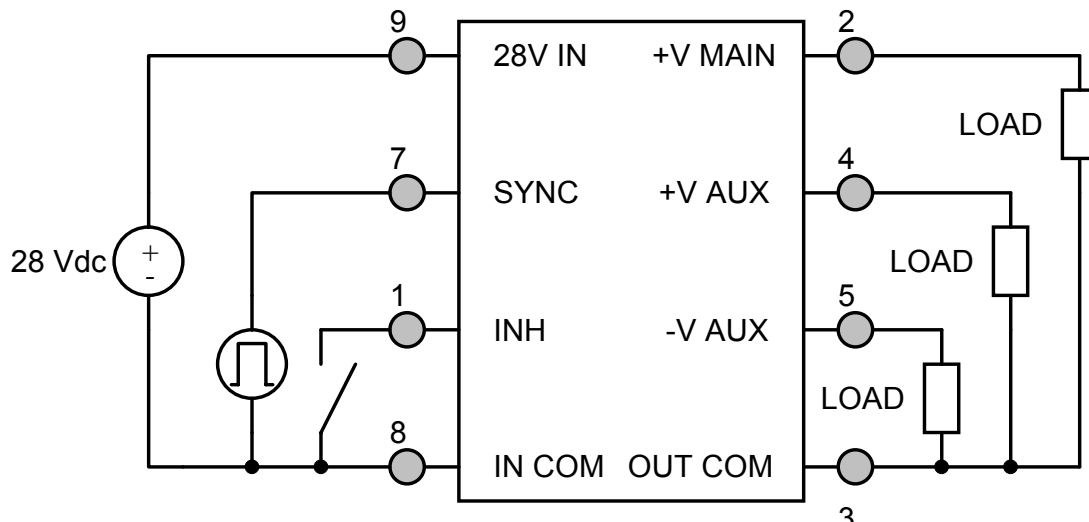

Figure 3

INHIBIT DRIVE CONNECTION DIAGRAMS

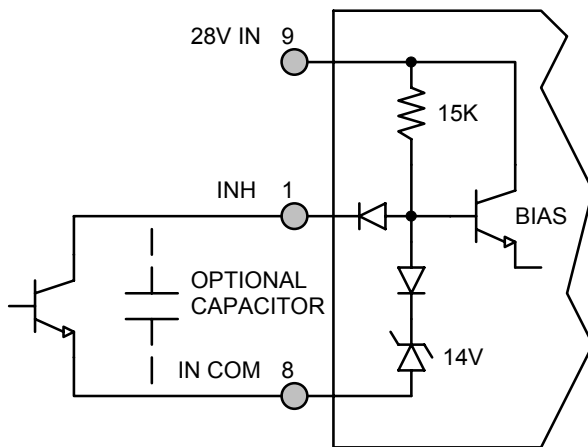

Figure 4 – Internal Inhibit Circuit and Recommended Drive
(Shown with optional capacitor for turn-on delay)

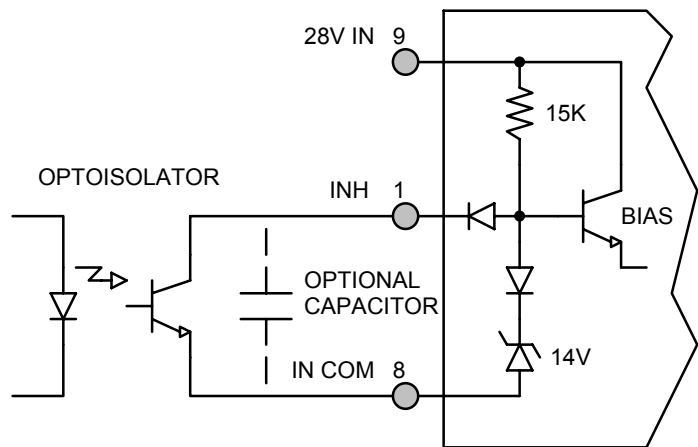

Figure 5 – Isolated Inhibit Drive
(Shown with optional capacitor for turn-on delay)

EMI FILTER HOOKUP DIAGRAM

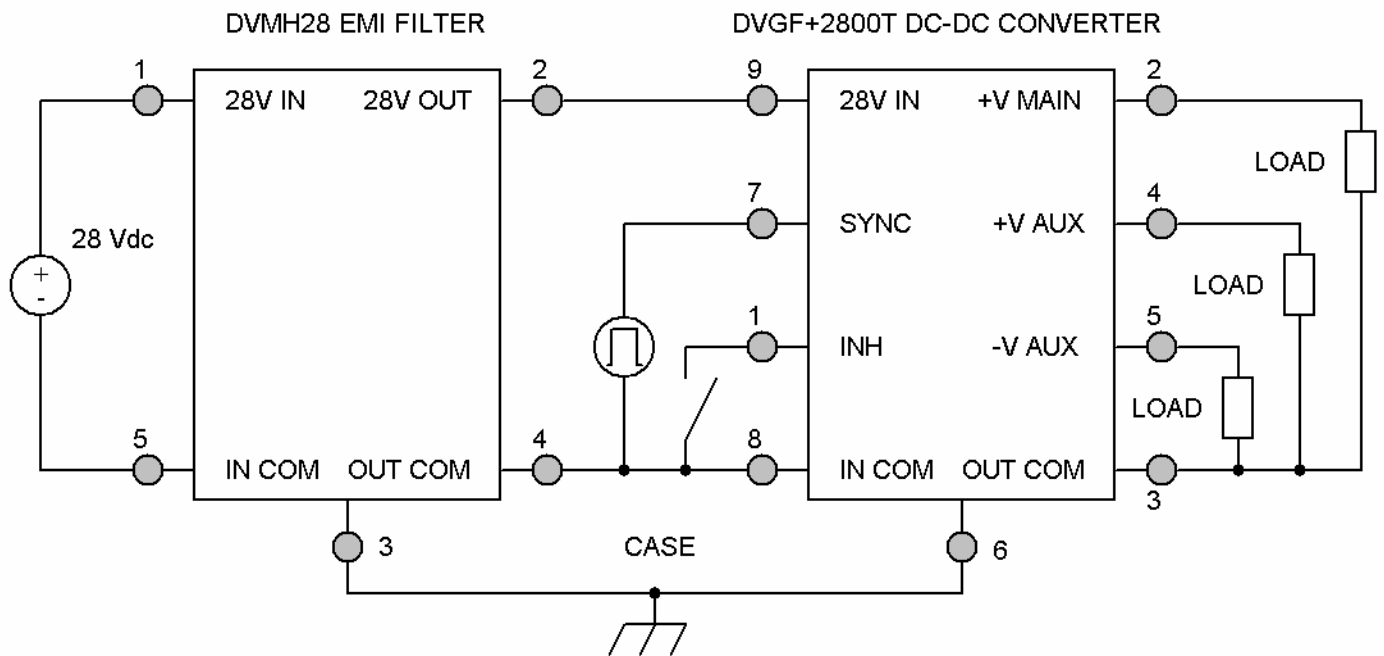

Figure 6 – Converter with EMI Filter

EFFICIENCY PERFORMANCE CURVES ($T_{CASE} = 25^{\circ}C$)

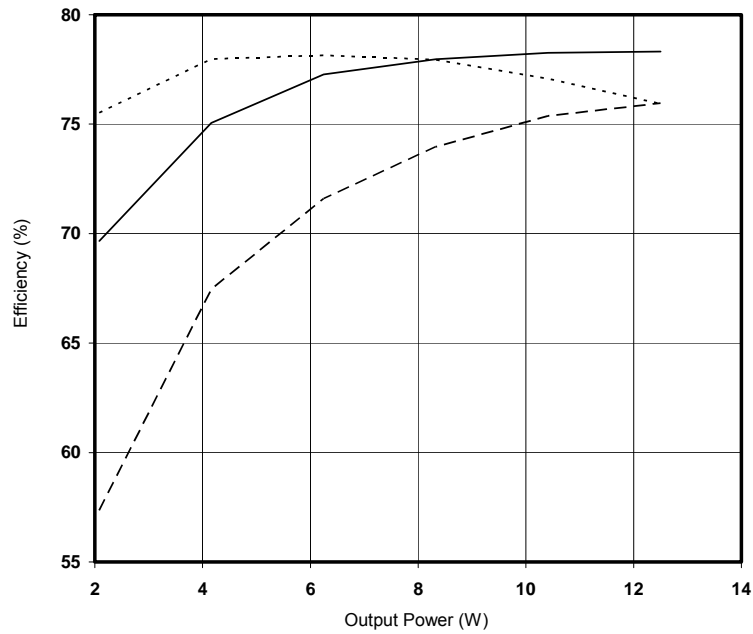

Figure 7 – DVGF+283R312T
Efficiency (%) vs. Output Power (W)

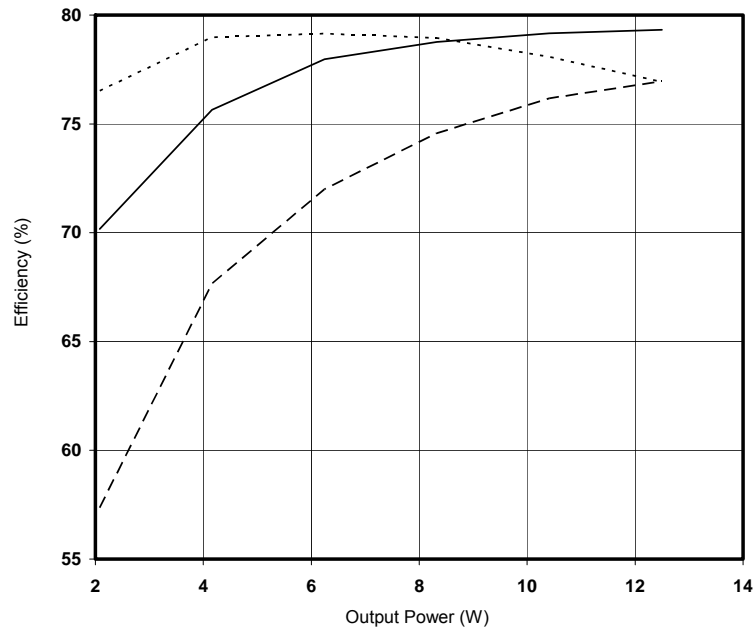

Figure 8 – DVGF+283R315T
Efficiency (%) vs. Output Power (W)

EMI PERFORMANCE CURVES

($T_{CASE} = 25^{\circ}C$, $V_{IN} = +28V \pm 5\%$, Full Load, Unless Otherwise Specified)

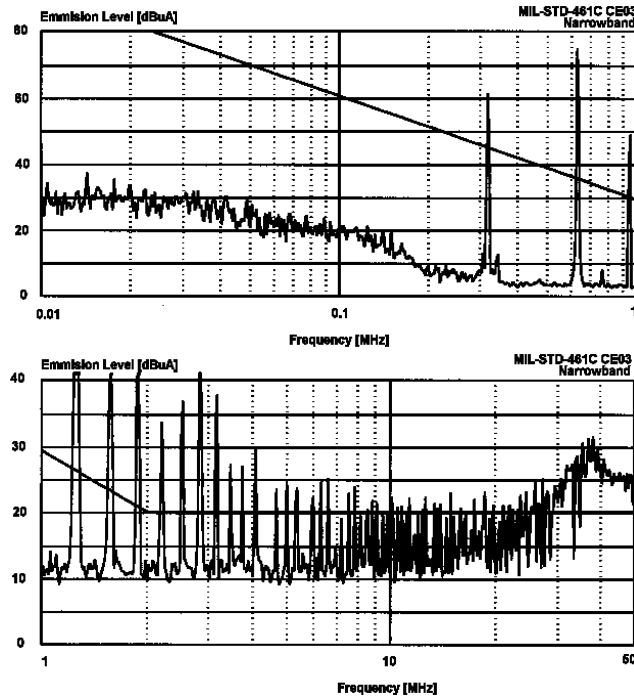

Figure 9 – DVGF+2800T without EMI Filter

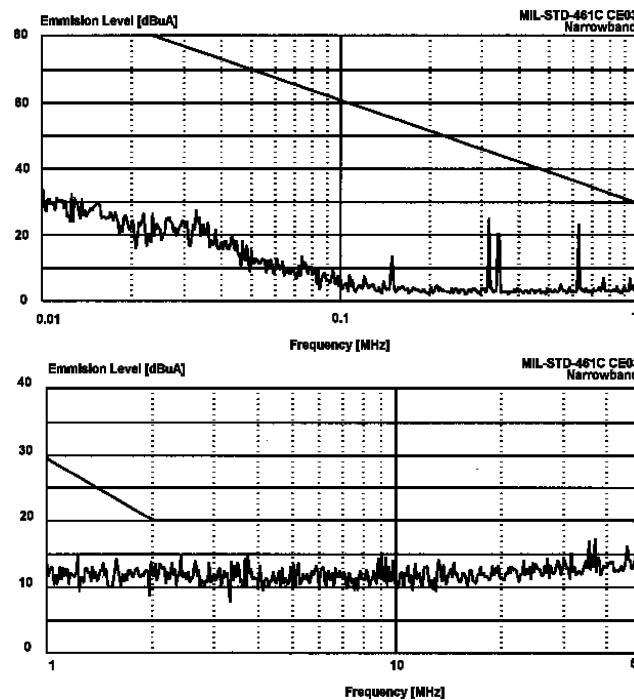
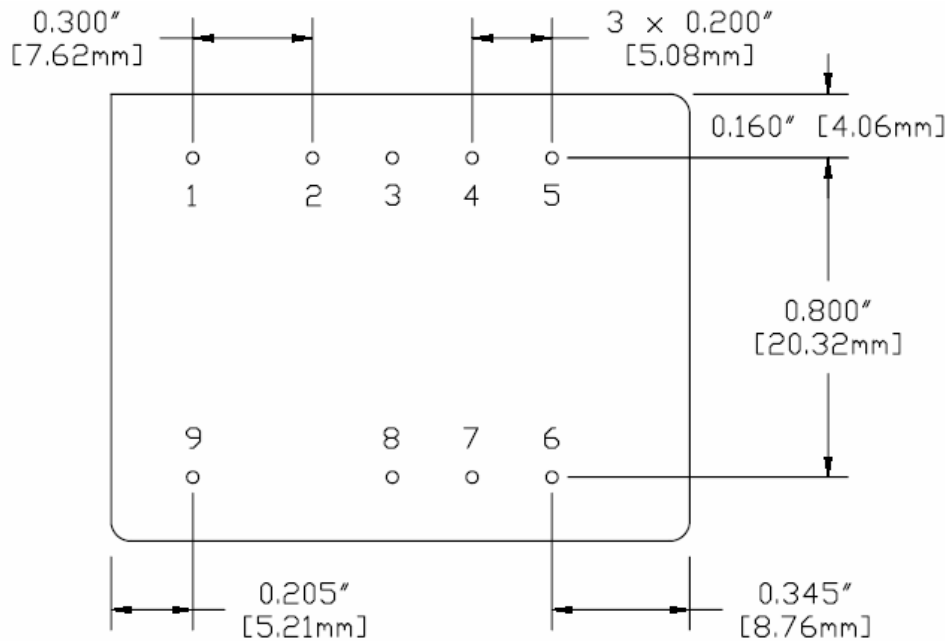
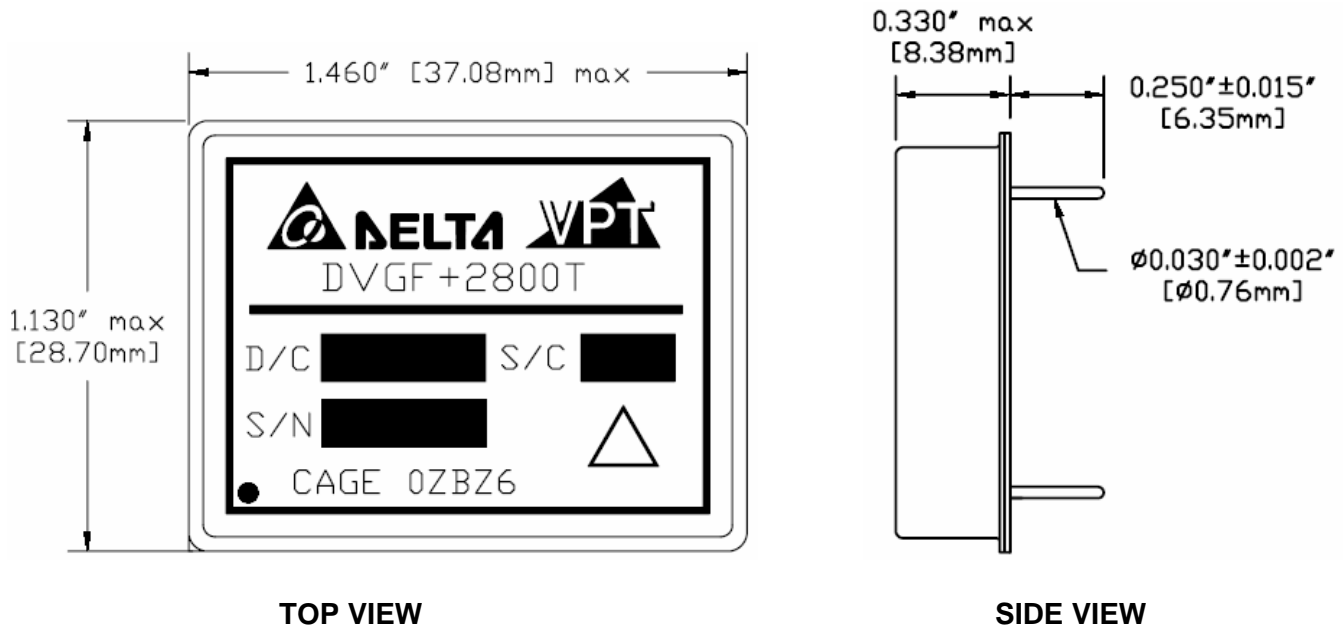

Figure 10 – DVGF+2800T with EMI Filter

PACKAGE SPECIFICATIONS (NON-FLANGED)



PIN	FUNCTION
1	INHIBIT
2	+V MAIN
3	OUT COM
4	+V AUX
5	-V AUX
6	CASE
7	SYNC
8	IN COM
9	28V IN

Figure 11 – Non-Flanged Package and Pinout
(Dimensional Limits are ± 0.005 " Unless Otherwise Stated)

PACKAGE SPECIFICATIONS (FLANGED)

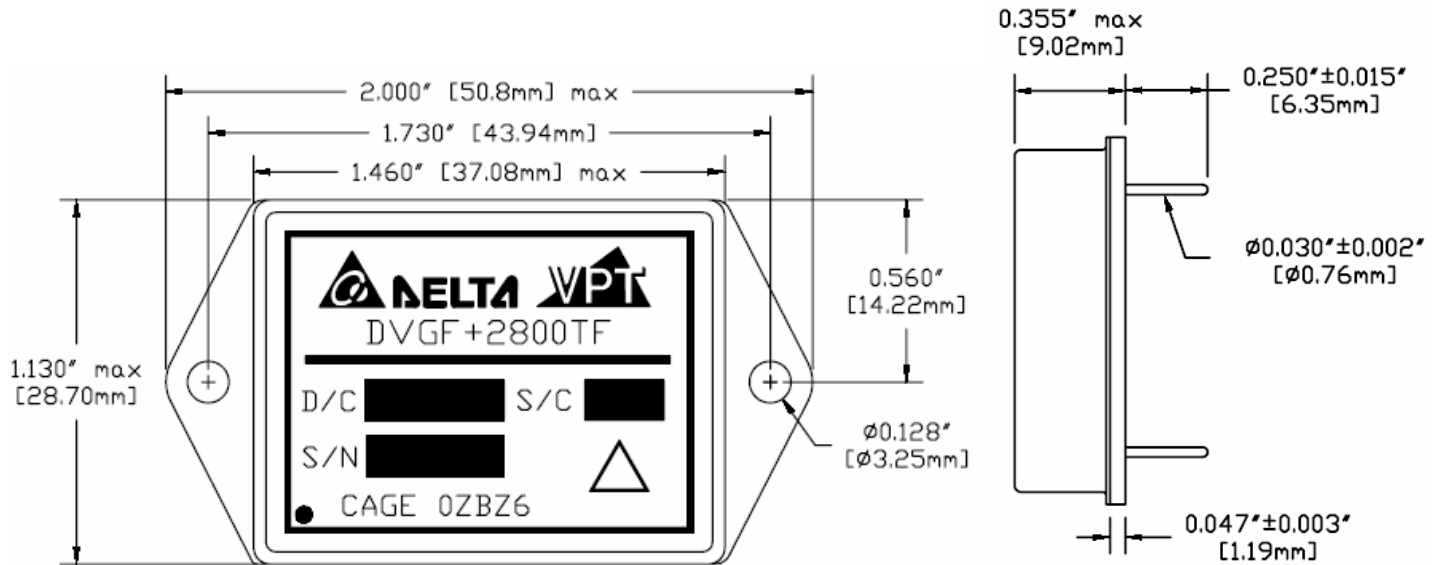

TOP VIEW

SIDE VIEW

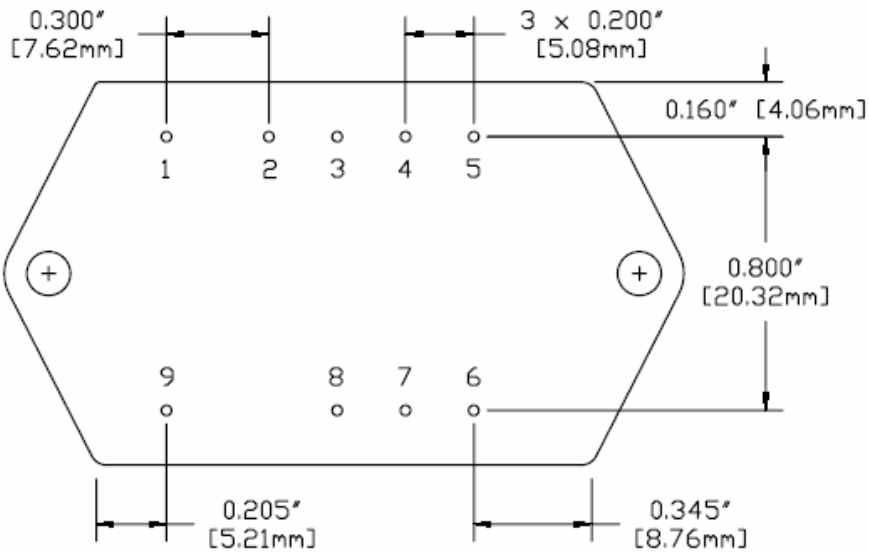

BOTTOM VIEW

PIN	FUNCTION
1	INHIBIT
2	+V MAIN
3	OUT COM
4	+V AUX
5	-V AUX
6	CASE
7	SYNC
8	IN COM
9	28V IN

Figure 12 – Flanged Package and Pinout
(Dimensional Limits are ± 0.005 " Unless Otherwise Stated)

PACKAGE PIN DESCRIPTION

Pin	Function	Description
1	INHIBIT	Logic Low = Disabled Output. Connecting the inhibit pin to input common causes converter shutdown. Logic High = Enabled Output. Unconnected or open collector TTL.
2	+V MAIN	Positive Main Output Voltage Connection
3	OUT COM	Output Common Connection
4	+V AUX	Positive Auxiliary Output Voltage Connection
5	-V AUX	Negative Auxiliary Output Voltage Connection
6	CASE	Case Connection
7	SYNC	Synchronization Signal
8	IN COM	Input Common Connection
9	28V IN	Positive Input Voltage Connection

ENVIRONMENTAL SCREENING (100% Tested Per MIL-STD-883 as referenced to MIL-PRF-38534)

Screening	MIL-STD-883	Standard (No Suffix)	Extended /ES	HB /HB	Class H /H	Class K /K
Non-Destructive Bond Pull	Method 2023	•	•	•	•	•
Internal Visual	Method 2017, 2032 Internal Procedure	•	•	•	•	•
Temperature Cycling	Method 1010, Condition C Method 1010, -55°C to 125°C		•	•	•	•
Constant Acceleration	Method 2001, 3000g, Y1 Direction Method 2001, 500g, Y1 Direction		•	•	•	•
PIND	Method 2020, Condition A ²					•
Pre Burn-In Electrical	100% at 25°C					•
Burn-In	Method 1015, 320 hours at +125°C Method 1015, 160 hours at +125°C 96 hours at +125°C 24 hours at +125°C	•	•	•	•	•
Final Electrical	MIL-PRF-38534, Group A ¹ 100% at 25°C	•	•	•	•	•
Hermeticity	Method 1014, Fine Leak, Condition A Method 1014, Gross Leak, Condition C Dip (1 x 10 ⁻³)	•	•	•	•	•
Radiography	Method 2012 ³					•
External Visual	Method 2009	•	•	•	•	•

- Notes:
1. 100% R&R testing at -55°C, +25°C, and +125°C with all test data included in product shipment.
 2. PIND test Certificate of Compliance included in product shipment.
 3. Radiographic test Certificate of Compliance and film(s) included in product shipment.

ORDERING INFORMATION

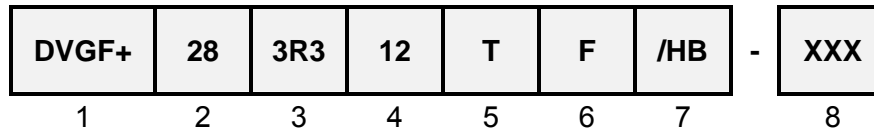

(1) Product Series	(2) Nominal Input Voltage		(3) Main Output Voltage		(4) Auxiliary Output Voltages	
DVGF+	28	28 Volts	3R3	+ 3.3 Volts	12 15	± 12 Volts ± 15 Volts

(5) Number of Outputs		(6) Package Option		(7) Screening Code ^{1,2}		(8) Additional Screening Code
T	Triple	None F	Non-Flanged Flanged	None /ES /HB /H /K	Standard Extended HB Class H Class K	Contact Sales

- Notes:
1. Contact the VPT Inc. Sales Department for availability of Class H (/H) or Class K (/K) qualified products.
 2. VPT Inc. reserves the right to ship higher screened or SMD products to meet lower screened orders at our sole discretion unless specifically forbidden by customer contract.

Please contact your sales representative or the VPT Inc. Sales Department for more information concerning additional environmental screening and testing, different input voltage, output voltage, power requirement, source inspection, and/or special element evaluation for space or other higher quality applications.

SMD (STANDARD MICROCIRCUIT DRAWING) NUMBERS

Standard Microcircuit Drawing (SMD)	DVGF+2800T Series Similar Part Number
*T.B.D.	DVGF+283R312T/H DVGF+283R312TF/H
*T.B.D.	DVGF+283R315T/H DVGF+283R315TF/H

Do not use the DVGF+2800T Series similar part number for SMD product acquisition. It is listed for reference only. For exact specifications for the SMD product, refer to the SMD drawing. SMD's can be downloaded from the DSCC website at <http://www.dscclia.mil/programs/smcr/>. The SMD number listed above is for MIL-PRF-38534 Class H screening, standard gold plated lead finish, and no RHA (Radiation Hardness Assurance) level. Please reference the SMD for other screening levels, lead finishes, and radiation levels.

CONTACT INFORMATION

To request a quotation or place orders please contact your sales representative or the VPT Inc. Sales Department at:

Phone: (425) 353-3010
Fax: (425) 353-4030
E-mail: vptsales@vpt-inc.com

All information contained in this datasheet is believed to be accurate, however, no responsibility is assumed for possible errors or omissions. The products or specifications contained herein are subject to change without notice.