



UT912D

CMOS IC

DECODERS FOR REMOTE CONTROLLER

DESCRIPTION

The UTC **UT912D** of CMOS LSIs for remote control system applications are paired with UTC **UT912E** (refer to the encoder/decoder cross reference table) and is capable of decoding information which consists of N address bits and 12-N data bits. For proper operation, a pair of encoder/decoder with the same number of addresses and data format should be chosen. The UTC **UT912D** also is arranged to provide 8 address bits and 4 data bits.

The decoders receive serial addresses and data from a programmed UTC **UT912E** of encoders that are transmitted together with the header bits by a RF or an infrared transmission medium upon receipt of a trigger signal. If no error or unmatched codes are found, the input data codes are decoded and then transferred to the output pins. The V_T pin also goes high to indicate a valid transmission.

FEATURES

- * Pair with UTC **UT912E**
- * Operating voltage: 2.4V ~ 12V
- * Low power and high noise immunity CMOS technology
- * Low standby current
- * Built-in oscillator needs only 5% resistor
- * Binary address setting
- * Received codes are checked 3 times
- * Capable of decoding 12 bits of information
- * Address/Data number combination: 8 address bits and 4 data bits
- * Valid transmission indicator
- * Minimal external components

ORDERING INFORMATION

Order Number		Package	Packing
Normal	Lead free		
UT912D-D18-T	UT912DL-D18-T	DIP-18	Tube
UT912D-S20-R	UT912DL-S20-R	SOP-20	Tape Reel
UT912D-S20-T	UT912DL-S20-T	SOP-20	Tube

ENCODER/DECODER CROSS REFERENCE TABLE

Decoder Part No.	Data Pins	Address Pins	V_T	Pair Encoder	Package			
					Encoder		Decoder	
UTC UT912D	4	8	√	UTC UT912E	DIP-14/18	SOP-16/20	DIP-18	SOP-20

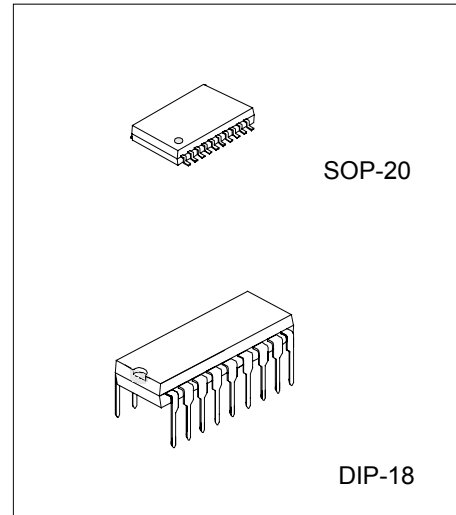

*Pb-free plating product number: UT912DL

■ PIN CONFIGURATION

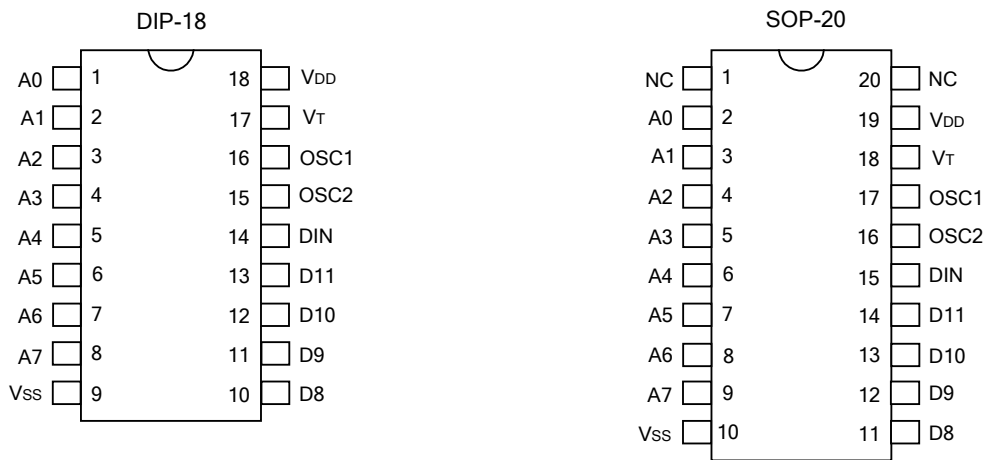

■ PIN DESCRIPTION

PIN NAME	I/O	INTERNAL CONNECTION	DESCRIPTION
A0 ~ A7	I	NMOS Transmission Gate	Input pins for address A0 ~ A7 setting, these pins can be externally set to V _{SS} or left open.
D8 ~ D11	O	CMOS OUT	Output data pins, power-on state is low.
DIN	I	CMOS IN	Serial data input pin
V _T	O	CMOS OUT	Valid transmission, active high
OSC1	I	Oscillator	Oscillator input pin
OSC2	O	Oscillator	Oscillator output pin
V _{SS}			Negative power supply, (GND)
V _{DD}			Positive power supply

■ BLOCK DIAGRAM

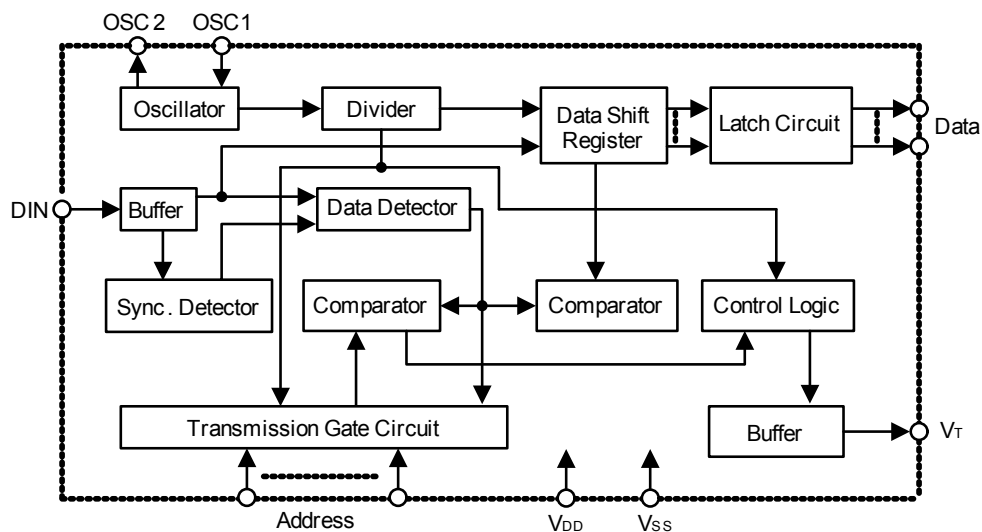

■ ABSOLUTE MAXIMUM RATINGS

PARAMETER	SYMBOL	RATINGS	UNIT
Supply Voltage	V_{DD}	-0.3 ~ +13	V
Input Voltage	V_{IN}	$V_{SS}-0.3 \sim V_{DD}+0.3$	V
Operating Temperature	T_{OPR}	0 ~ +70	°C
Storage Temperature	T_{STG}	-40 ~ +150	°C

Note: Absolute maximum ratings are those values beyond which the device could be permanently damaged. Absolute maximum ratings are stress ratings only and functional device operation is not implied.

■ ELECTRICAL CHARACTERISTICS (Ta=25°C, V_{DD}=5V, unless otherwise specified.)

PARAMETER	SYMBOL	TEST CONDITIONS	MIN	TYP	MAX	UNIT
Operating Voltage	V_{OPR}		2.4	5	12	V
Standby Current	I_{STN-BY}	Oscillator stops				μA
		$V_{DD}=5V$		0.1	1	
		$V_{DD}=12V$		2	4	
Operating Current	I_{OPR}	No load, $f_{OSC}=150kHz$, $V_{DD}=5V$		159	400	μA
Data Output Current (D8~D11)	I_{DOUT}	$V_{DD}=5V$	$V_{OH}=4.5V$ (Source)	-1	-1.99	mA
			$V_{OL}=0.5V$ (Sink)	1	1.9	
V_T Output Current	I_{VT}	$V_{DD}=5V$	$V_{OH}=4.5V$ (Source)	-1	-1.564	mA
			$V_{OL}=0.5V$ (Sink)	1	1.53	
Input Voltage	High	V_{IH}			5	V
	Low	V_{IL}		0	1	V
Oscillator Frequency	f_{OSC}	$R_{OSC}=1.1M\Omega$, $V_{DD}=5V$		149		kHz

■ OPERATION FLOWCHART

The oscillator is disabled in the standby state and activated when a logic “high” signal applies to the DIN pin. That is to say, the DIN should be kept low if there is no signal input.

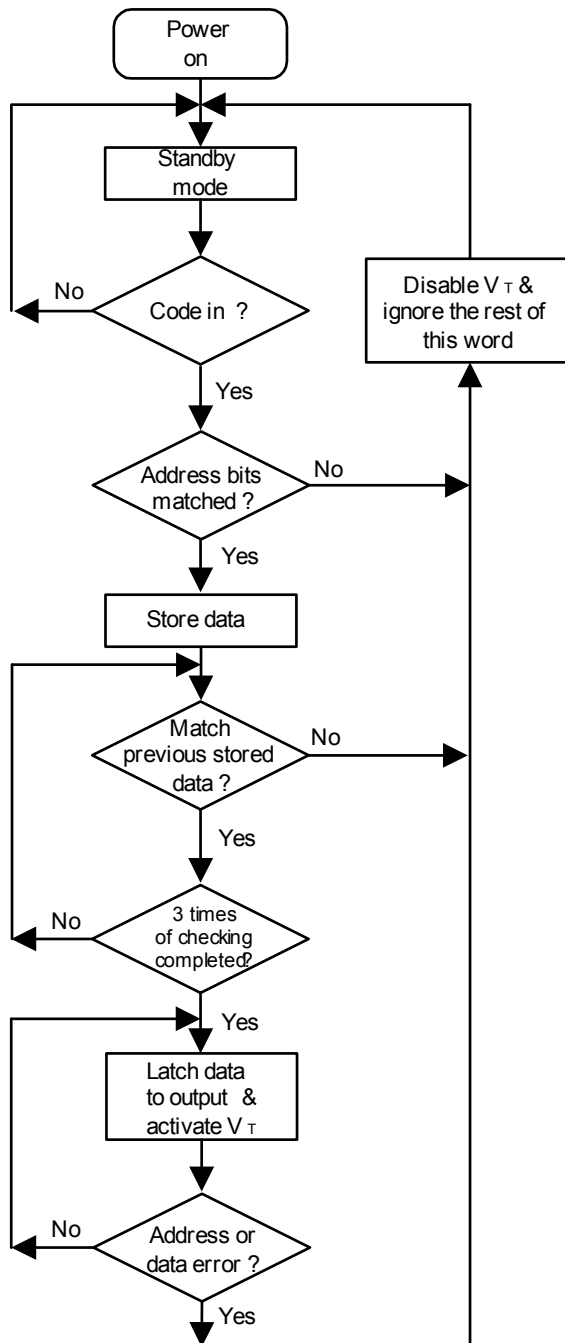

FUNCTIONAL DESCRIPTION

Operation

The UTC **UT912D** offers different packages by various combinations of addresses and data pins to pair with the UTC **UT912E**. The decoders receive data that are transmitted by an encoder and interpret the first N bits of code period as addresses and the last 12-N bits as data, where N is the address code number. A signal on the DIN pin activates the oscillator, which in turn decodes the incoming address and data. The decoders will then check the received address three times continuously. If the received address codes all match the contents of the decoder's local address, the 12-N bits of data are decoded to activate the output pins and the V_T pin is set high to indicate a valid transmission. This will last unless the address code is incorrect or no signal is received. The output of the V_T pin is high only when the transmission is valid. Otherwise it is always low.

Decoder timing

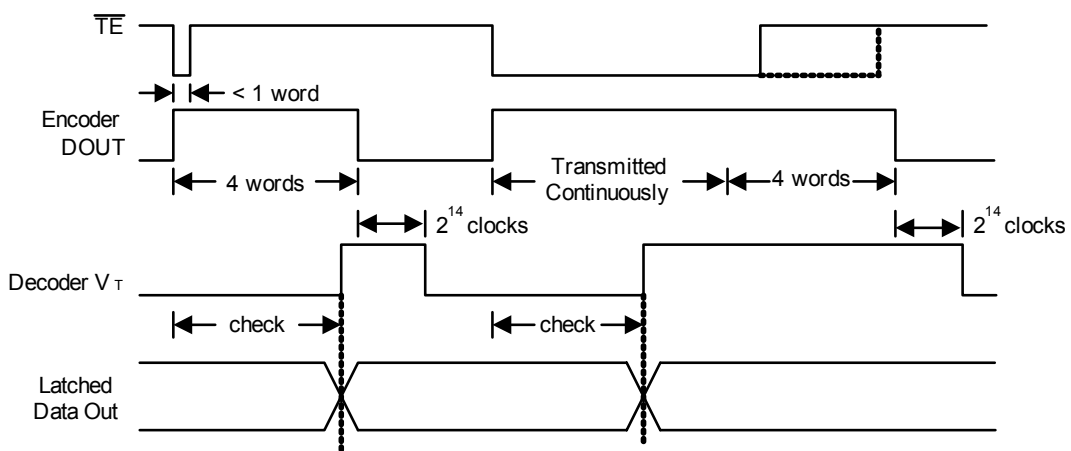

Address/Data sequence

The following provides the address/data sequence table for various models of the UTC UT912D. The correct device should be selected according to the individual address and data requirements.

Bits	0	1	2	3	4	5	6	7	8	9	10	11
Address/ Data	A0	A1	A2	A3	A4	A5	A6	A7	D8	D9	D10	D11

■ APPLICATION CIRCUITS

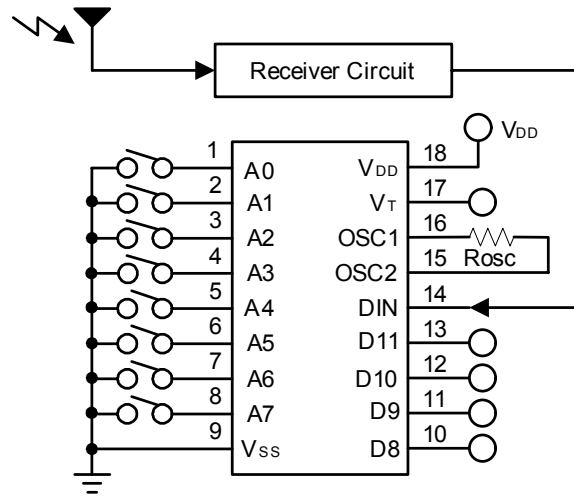

■ APPROXIMATE INTERNAL CONNECTION CIRCUITS

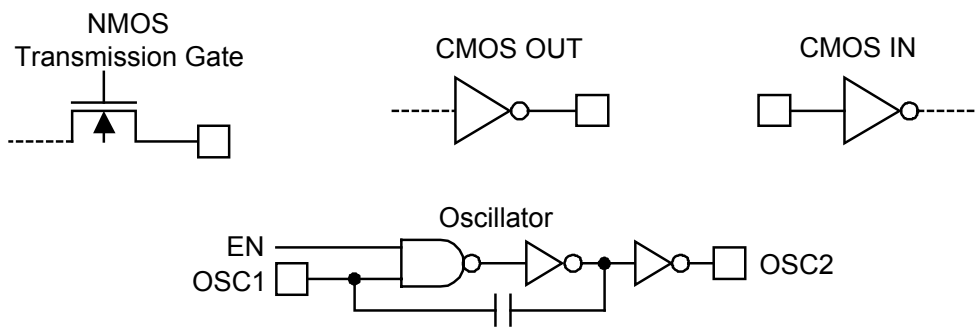

■ OSCILLATOR FREQUENCY VS SUPPLY VOLTAGE

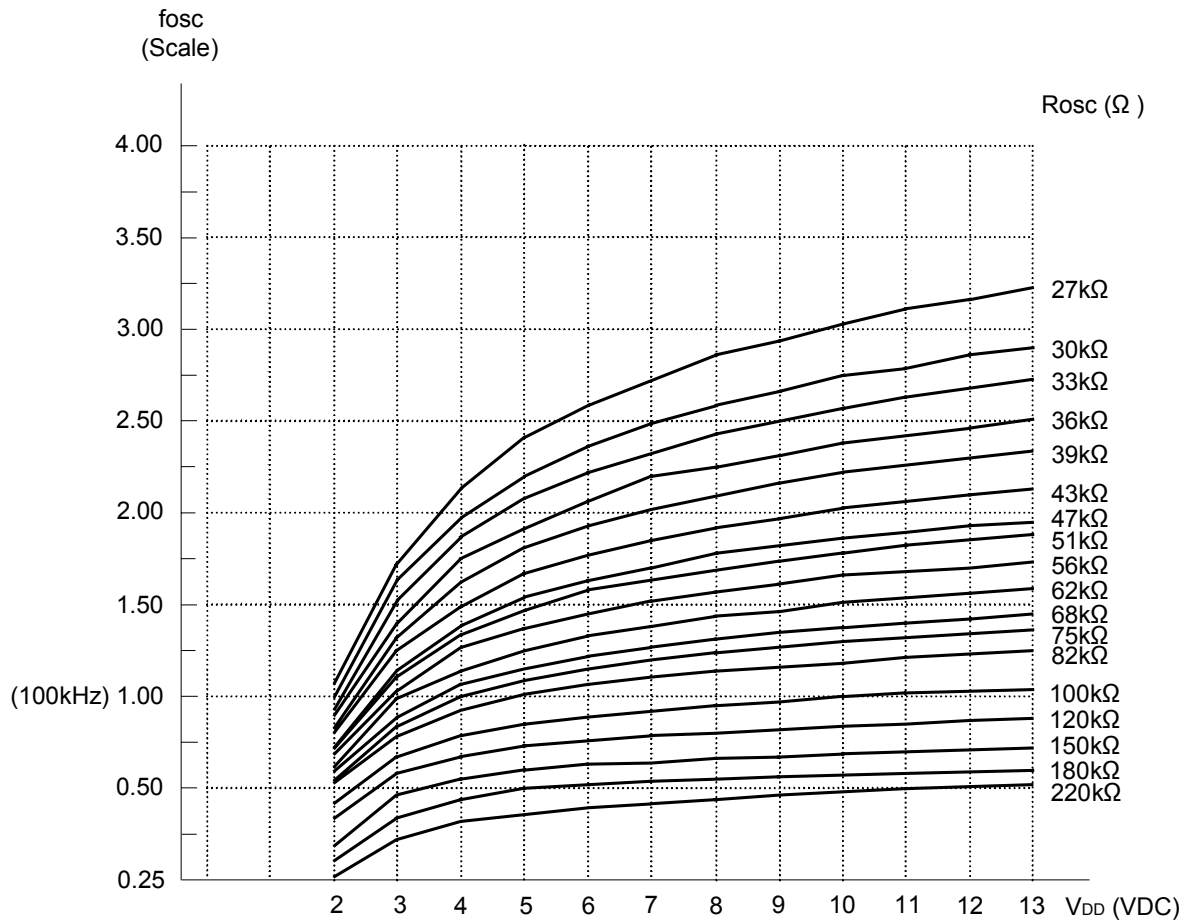

Note: The recommended oscillator frequency is f_{OSCD} (decoder) \cong 50 f_{OSCE} (UTC UT912E encoder)

UTC assumes no responsibility for equipment failures that result from using products at values that exceed, even momentarily, rated values (such as maximum ratings, operating condition ranges, or other parameters) listed in products specifications of any and all UTC products described or contained herein. UTC products are not designed for use in life support appliances, devices or systems where malfunction of these products can be reasonably expected to result in personal injury. Reproduction in whole or in part is prohibited without the prior written consent of the copyright owner. The information presented in this document does not form part of any quotation or contract, is believed to be accurate and reliable and may be changed without notice.