

# DATA SHEET

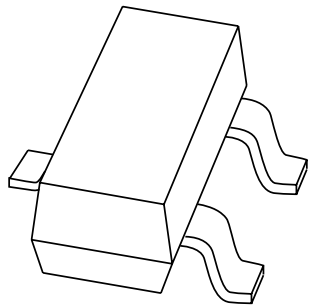

**PBSS5160T**

60 V, 1 A

PNP low  $V_{CEsat}$  (BISS) transistor

Product specification  
Supersedes data of 2003 Jun 23

2004 May 27

**60 V, 1 A**  
**PNP low  $V_{CEsat}$  (BISS) transistor**

**PBSS5160T**

**FEATURES**

- Low collector-emitter saturation voltage  $V_{CEsat}$
- High collector current capability:  $I_C$  and  $I_{CM}$
- High efficiency, reduces heat generation
- Reduces printed-circuit board area required
- Cost effective replacement for medium power transistors BCP52 and BCX52.

**APPLICATIONS**

- Major application segments:
  - Automotive
  - Telecom infrastructure
  - Industrial.
- Power management:
  - DC-to-DC conversion
  - Supply line switching.
- Peripheral driver:
  - Driver in low supply voltage applications (e.g. lamps and LEDs)
  - Inductive load driver (e.g. relays, buzzers and motors).

**DESCRIPTION**

PNP low  $V_{CEsat}$  transistor in a SOT23 plastic package.  
 NPN complement: PBSS4160T.

**MARKING**

TYPE NUMBER	MARKING CODE <sup>(1)</sup>
PBSS5160T	U6*

**Note**

1. \* = p: made in Hong Kong  
 \* = t: made in Malaysia  
 \* = W: made in China.

**ORDERING INFORMATION**

TYPE NUMBER	PACKAGE		
	NAME	DESCRIPTION	VERSION
PBSS5160T	–	plastic surface mounted package; 3 leads	SOT23

**QUICK REFERENCE DATA**

SYMBOL	PARAMETER	MAX.	UNIT
$V_{CEO}$	collector-emitter voltage	–60	V
$I_C$	collector current (DC)	–1	A
$I_{CM}$	peak collector current	–2	A
$R_{CEsat}$	equivalent on-resistance	330	m $\Omega$

**PINNING**

PIN	DESCRIPTION
1	base
2	emitter
3	collector

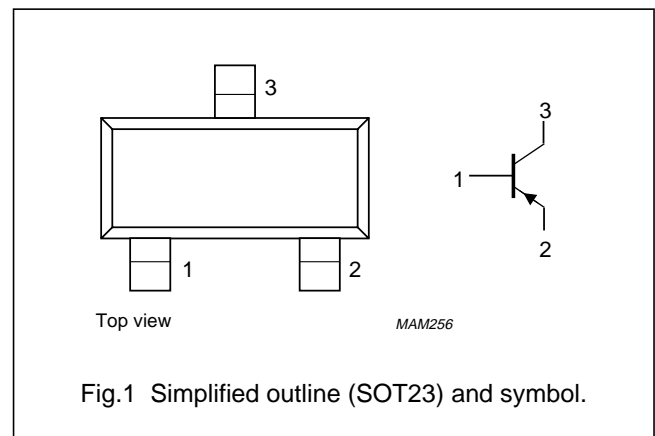

60 V, 1 A  
PNP low  $V_{CEsat}$  (BISS) transistor

PBSS5160T

**LIMITING VALUES**

In accordance with the Absolute Maximum Rating System (IEC 60134).

SYMBOL	PARAMETER	CONDITIONS	MIN.	MAX.	UNIT
$V_{CBO}$	collector-base voltage	open emitter	–	–80	V
$V_{CEO}$	collector-emitter voltage	open base	–	–60	V
$V_{EBO}$	emitter-base voltage	open collector	–	–5	V
$I_C$	collector current (DC)	note 1	–	–0.9	A
		note 2	–	–1	A
$I_{CM}$	peak collector current	$t = 1 \text{ ms}$ or limited by $T_{j(max)}$	–	–2	A
$I_B$	base current (DC)		–	–300	mA
$I_{BM}$	peak base current	$t_p \leq 300 \mu\text{s}; \delta \leq 0.02$	–	–1	A
$P_{tot}$	total power dissipation	$T_{amb} \leq 25 \text{ }^\circ\text{C};$ note 1	–	270	mW
		note 2	–	400	mW
		notes 1 and 3	–	1.25	W
$T_{stg}$	storage temperature		–65	+150	$^\circ\text{C}$
$T_j$	junction temperature		–	150	$^\circ\text{C}$
$T_{amb}$	operating ambient temperature		–65	+150	$^\circ\text{C}$

**Notes**

1. Device mounted on an FR4 printed-circuit board, single-sided copper, tin-plated and standard footprint.
2. Device mounted on an FR4 printed-circuit board, single-sided copper, tin-plated and 1 cm<sup>2</sup> collector mounting pad.
3. Operated under pulsed conditions: duty cycle  $\delta \leq 20 \%$ , pulse width  $t_p \leq 10 \text{ ms}$ .

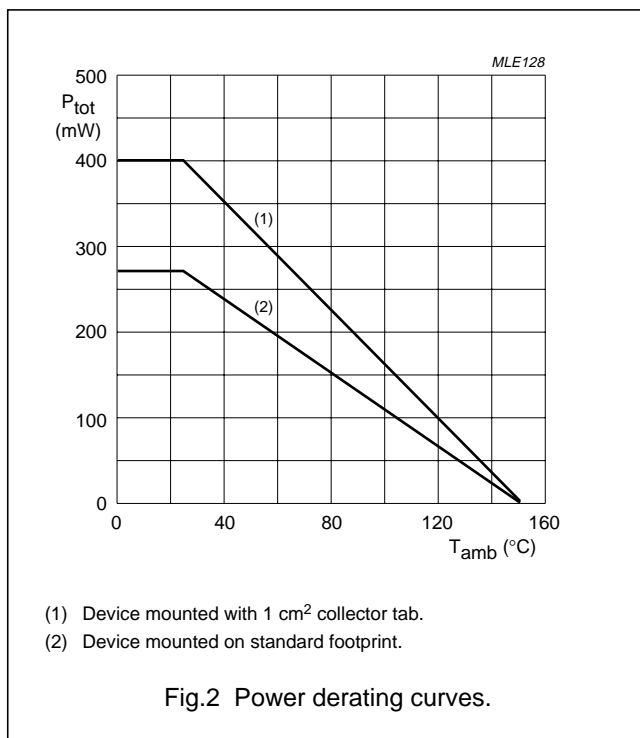

60 V, 1 A  
PNP low  $V_{CEsat}$  (BISS) transistor

PBSS5160T

**THERMAL CHARACTERISTICS**

SYMBOL	PARAMETER	CONDITIONS	VALUE	UNIT
$R_{th(j-a)}$	thermal resistance from junction to ambient	in free air; note 1	465	K/W
		in free air; note 2	312	K/W
		in free air; notes 1 and 3	100	K/W

**Notes**

1. Device mounted on an FR4 printed-circuit board, single-sided copper, tin-plated and standard footprint.
2. Device mounted on an FR4 printed-circuit board, single-sided copper, tin-plated and 1 cm<sup>2</sup> collector mounting pad.
3. Operated under pulsed conditions: duty cycle  $\delta \leq 20\%$ , pulse width  $t_p \leq 10$  ms.

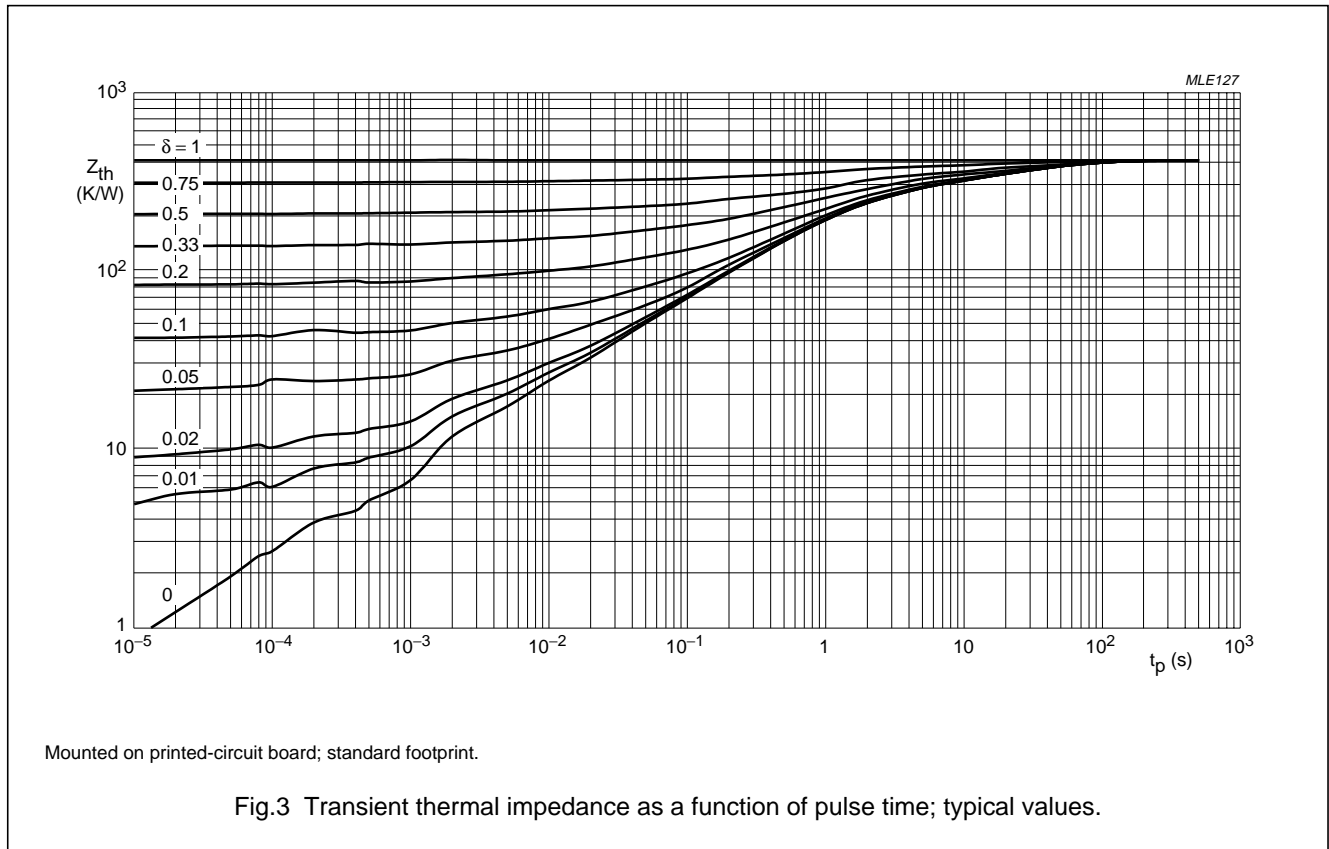

60 V, 1 A  
PNP low  $V_{CEsat}$  (BISS) transistor

PBSS5160T

**CHARACTERISTICS**

$T_{amb} = 25\text{ }^\circ\text{C}$  unless otherwise specified.

SYMBOL	PARAMETER	CONDITIONS	MIN.	TYP.	MAX.	UNIT
$I_{CBO}$	collector-base cut-off current	$V_{CB} = -60\text{ V}; I_E = 0\text{ A}$	-	-	-100	nA
		$V_{CB} = -60\text{ V}; I_E = 0\text{ A}; T_j = 150\text{ }^\circ\text{C}$	-	-	-50	$\mu\text{A}$
$I_{CES}$	collector-emitter cut-off current	$V_{CE} = -60\text{ V}; V_{BE} = 0\text{ V}$	-	-	-100	nA
$I_{EBO}$	emitter-base cut-off current	$V_{EB} = -5\text{ V}; I_C = 0\text{ A}$	-	-	-100	nA
$h_{FE}$	DC current gain	$V_{CE} = -5\text{ V}; I_C = -1\text{ mA}$	200	350	-	
		$V_{CE} = -5\text{ V}; I_C = -500\text{ mA}$ ; note 1	150	250	-	
		$V_{CE} = -5\text{ V}; I_C = -1\text{ A}$ ; note 1	100	160	-	
$V_{CEsat}$	collector-emitter saturation voltage	$I_C = -100\text{ mA}; I_B = -1\text{ mA}$	-	-110	-160	mV
		$I_C = -500\text{ mA}; I_B = -50\text{ mA}$	-	-120	-175	mV
		$I_C = -1\text{ A}; I_B = -100\text{ mA}$ ; note 1	-	-220	-330	mV
$V_{BEsat}$	base-emitter saturation voltage	$I_C = -1\text{ A}; I_B = -50\text{ mA}$	-	-0.95	-1.1	V
$R_{CEsat}$	equivalent on-resistance	$I_C = -1\text{ A}; I_B = -100\text{ mA}$ ; note 1	-	220	330	$\text{m}\Omega$
$V_{BEon}$	base-emitter turn-on voltage	$V_{CE} = -5\text{ V}; I_C = -1\text{ A}$	-	-0.82	-0.9	V
$f_T$	transition frequency	$I_C = -50\text{ mA}; V_{CE} = -10\text{ V}; f = 100\text{ MHz}$	150	220	-	MHz
$C_c$	collector capacitance	$V_{CB} = -10\text{ V}; I_E = I_e = 0\text{ A}; f = 1\text{ MHz}$	-	9	15	pF

**Note**

1. Pulse test:  $t_p \leq 300\text{ }\mu\text{s}$ ;  $\delta \leq 0.02$ .

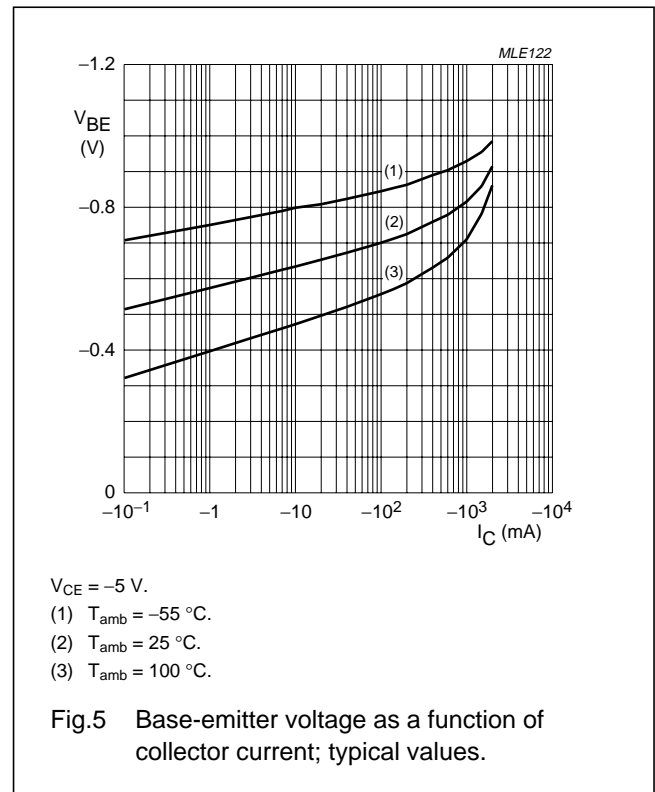
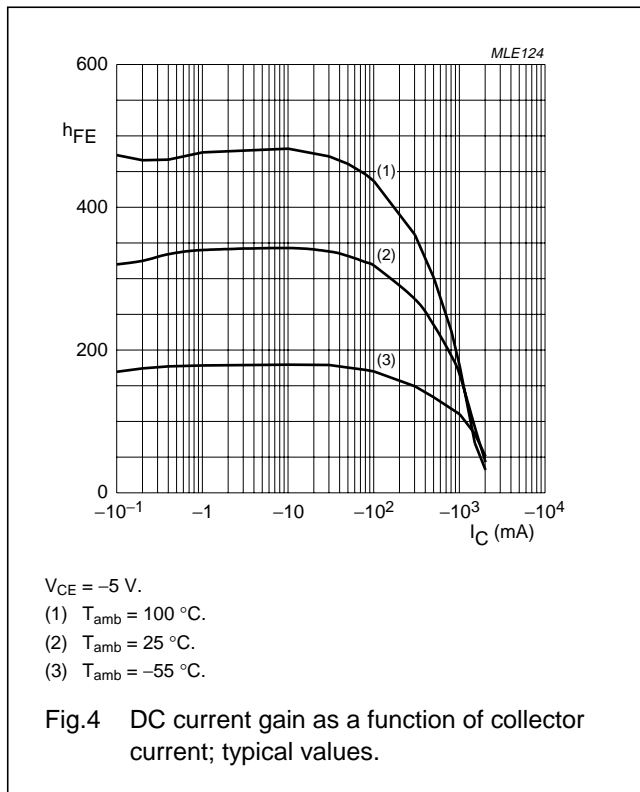

60 V, 1 A  
PNP low  $V_{CEsat}$  (BISS) transistor

PBSS5160T

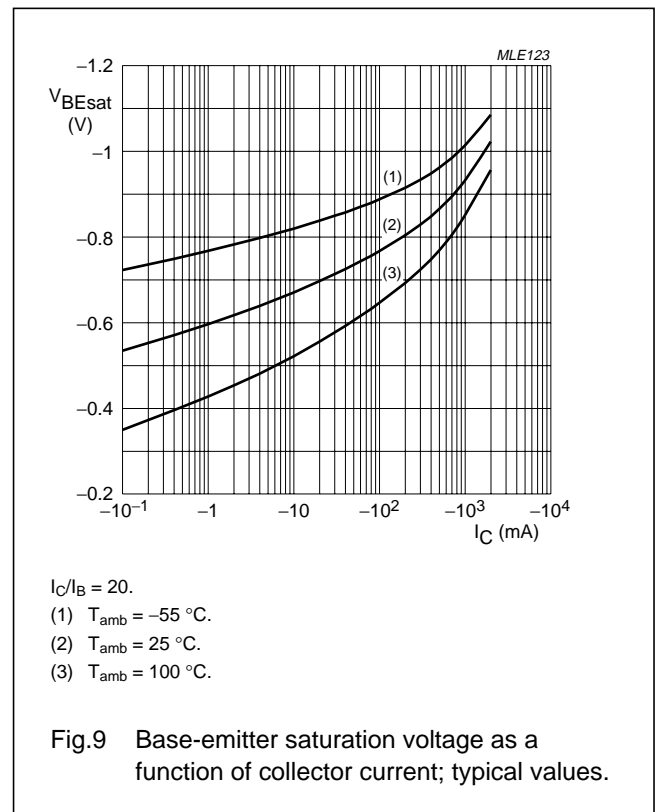
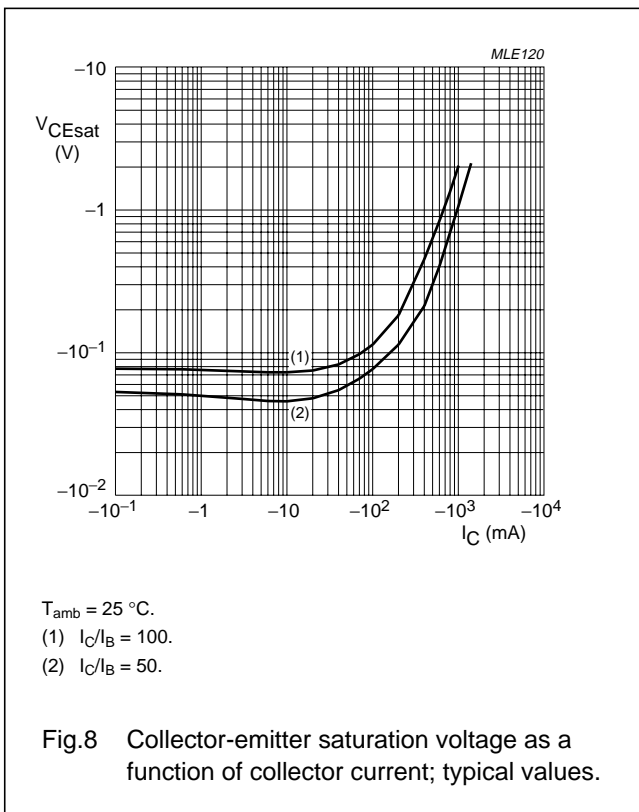
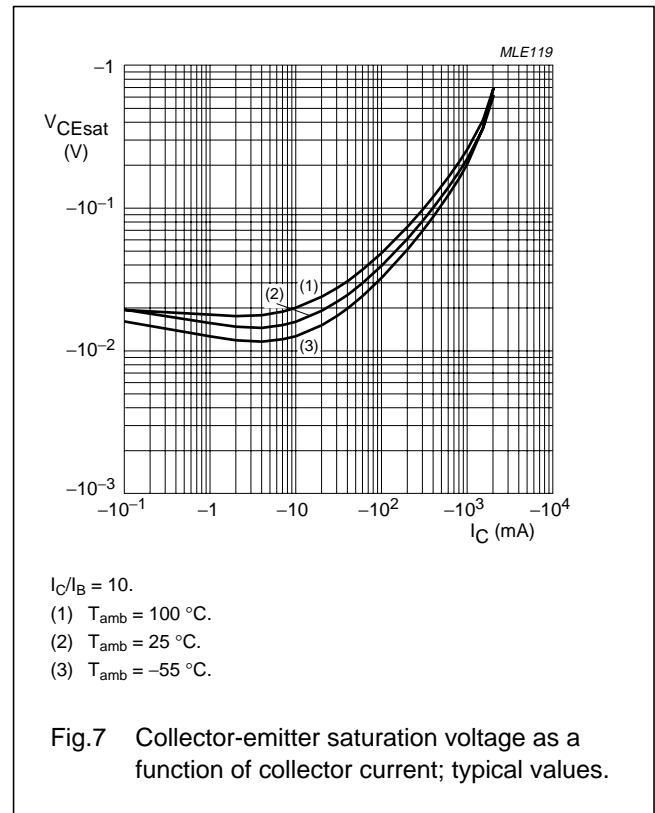
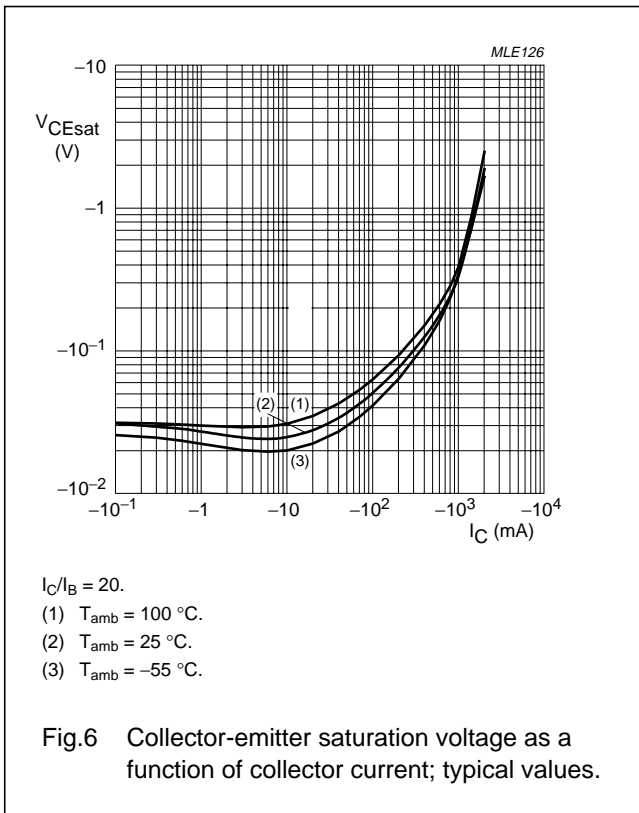

60 V, 1 A  
PNP low  $V_{CEsat}$  (BISS) transistor

PBSS5160T

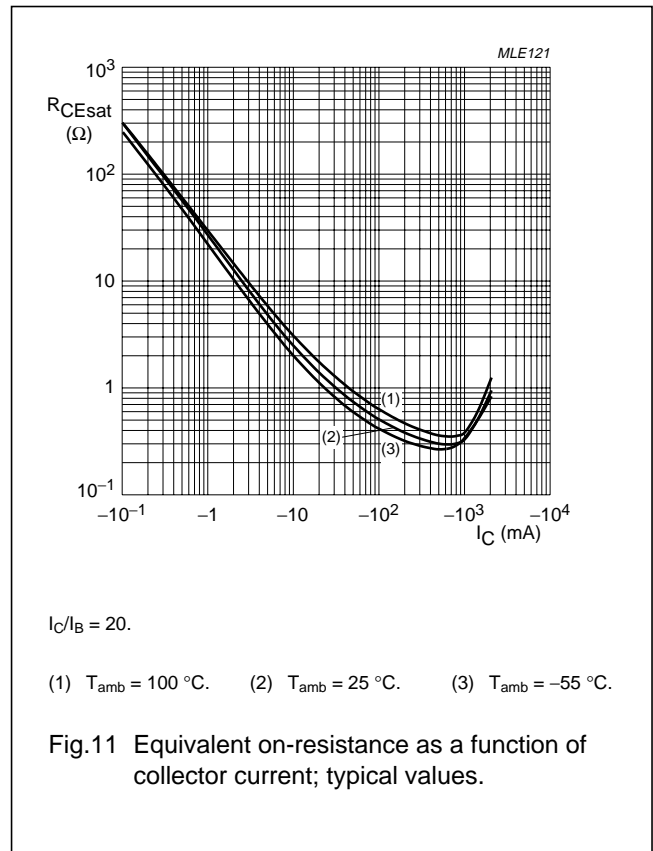
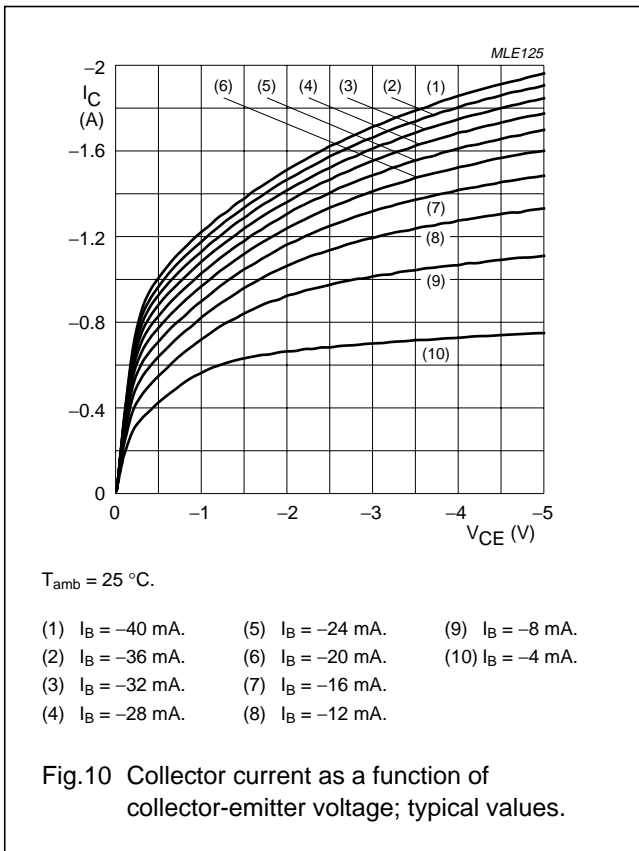

60 V, 1 A  
PNP low  $V_{CEsat}$  (BISS) transistor

PBSS5160T

PACKAGE OUTLINE

Plastic surface mounted package; 3 leads

SOT23

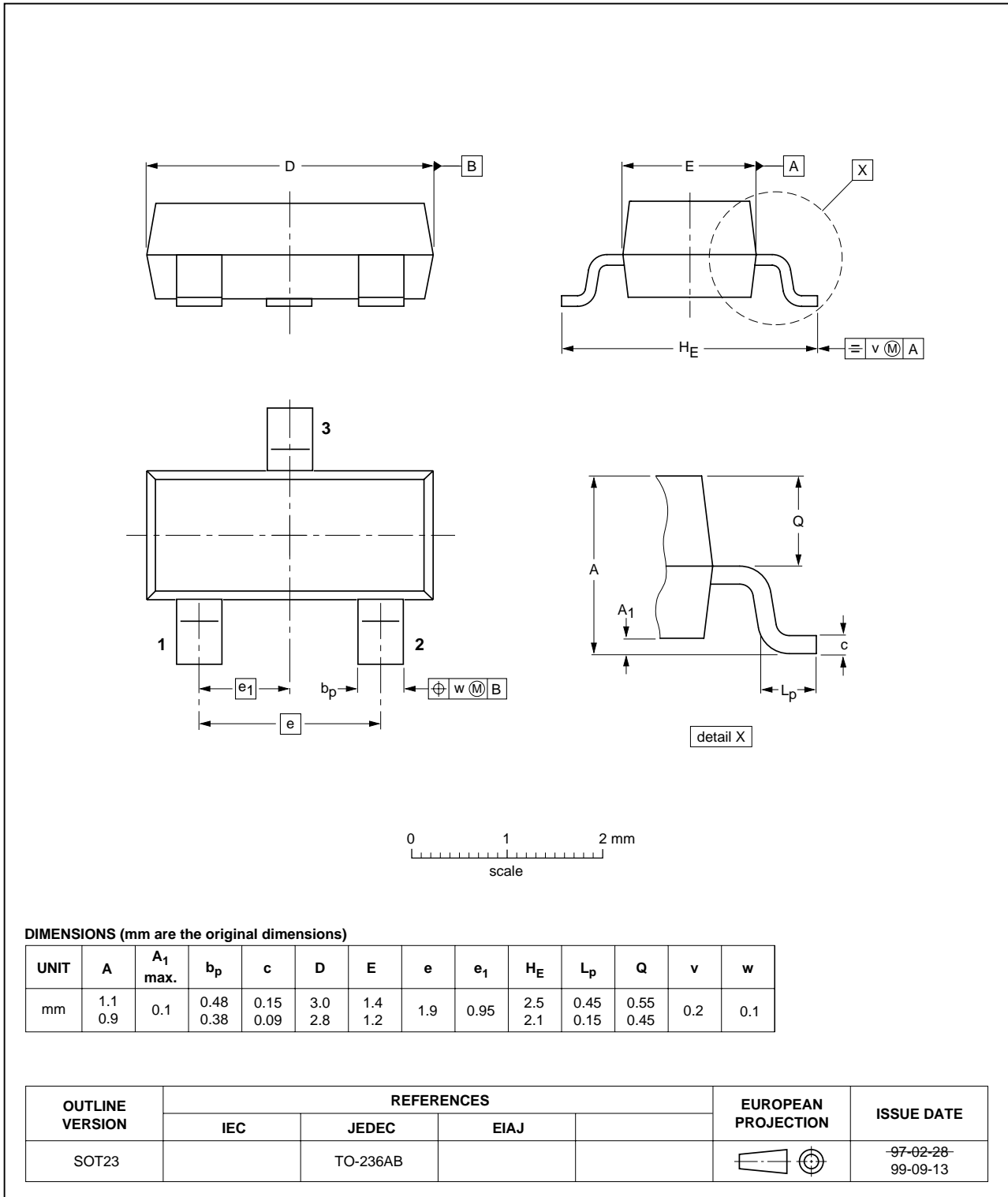



60 V, 1 A  
PNP low  $V_{CEsat}$  (BISS) transistor

PBSS5160T

**DATA SHEET STATUS**

LEVEL	DATA SHEET STATUS <sup>(1)</sup>	PRODUCT STATUS <sup>(2)(3)</sup>	DEFINITION
I	Objective data	Development	This data sheet contains data from the objective specification for product development. Philips Semiconductors reserves the right to change the specification in any manner without notice.
II	Preliminary data	Qualification	This data sheet contains data from the preliminary specification. Supplementary data will be published at a later date. Philips Semiconductors reserves the right to change the specification without notice, in order to improve the design and supply the best possible product.
III	Product data	Production	This data sheet contains data from the product specification. Philips Semiconductors reserves the right to make changes at any time in order to improve the design, manufacturing and supply. Relevant changes will be communicated via a Customer Product/Process Change Notification (CPCN).

**Notes**

1. Please consult the most recently issued data sheet before initiating or completing a design.
2. The product status of the device(s) described in this data sheet may have changed since this data sheet was published. The latest information is available on the Internet at URL <http://www.semiconductors.philips.com>.
3. For data sheets describing multiple type numbers, the highest-level product status determines the data sheet status.

**DEFINITIONS**

**Short-form specification** — The data in a short-form specification is extracted from a full data sheet with the same type number and title. For detailed information see the relevant data sheet or data handbook.

**Limiting values definition** — Limiting values given are in accordance with the Absolute Maximum Rating System (IEC 60134). Stress above one or more of the limiting values may cause permanent damage to the device. These are stress ratings only and operation of the device at these or at any other conditions above those given in the Characteristics sections of the specification is not implied. Exposure to limiting values for extended periods may affect device reliability.

**Application information** — Applications that are described herein for any of these products are for illustrative purposes only. Philips Semiconductors make no representation or warranty that such applications will be suitable for the specified use without further testing or modification.

**DISCLAIMERS**

**Life support applications** — These products are not designed for use in life support appliances, devices, or systems where malfunction of these products can reasonably be expected to result in personal injury. Philips Semiconductors customers using or selling these products for use in such applications do so at their own risk and agree to fully indemnify Philips Semiconductors for any damages resulting from such application.

**Right to make changes** — Philips Semiconductors reserves the right to make changes in the products - including circuits, standard cells, and/or software - described or contained herein in order to improve design and/or performance. When the product is in full production (status 'Production'), relevant changes will be communicated via a Customer Product/Process Change Notification (CPCN). Philips Semiconductors assumes no responsibility or liability for the use of any of these products, conveys no license or title under any patent, copyright, or mask work right to these products, and makes no representations or warranties that these products are free from patent, copyright, or mask work right infringement, unless otherwise specified.

# ***Philips Semiconductors – a worldwide company***

## **Contact information**

For additional information please visit <http://www.semiconductors.philips.com>. Fax: +31 40 27 24825

For sales offices addresses send e-mail to: [sales.addresses@www.semiconductors.philips.com](mailto:sales.addresses@www.semiconductors.philips.com).

© Koninklijke Philips Electronics N.V. 2004

SCA76

All rights are reserved. Reproduction in whole or in part is prohibited without the prior written consent of the copyright owner.

The information presented in this document does not form part of any quotation or contract, is believed to be accurate and reliable and may be changed without notice. No liability will be accepted by the publisher for any consequence of its use. Publication thereof does not convey nor imply any license under patent- or other industrial or intellectual property rights.

Printed in The Netherlands

R75/02/pp10

Date of release: 2004 May 27

Document order number: 9397 750 13284

*Let's make things better.*

**Philips  
Semiconductors**



**PHILIPS**