

MSM9210

32-Bit Duplex/Triplex (1/2 duty / 1/3 duty) VF Controller/Driver with Digital Dimming

GENERAL DESCRIPTION

The MSM9210 is a full CMOS controller/driver for Duplex or Triplex (1/2 duty or 1/3 duty) vacuum fluorescent display tube. It consists of a 32-segment driver multiplexed to drive up to 96 segments, and 10-bit digital dimming circuit.

MSM9210 features a selection of a master mode and a slave mode, and therefore it can be used to expand segments for the VFD driver with keyscan and A/D converter function.

MSM9210 provides an interface with a microcontroller only by three signal lines: DATA IN, CLOCK and CS.

FEATURES

- Logic supply voltage (V_{DD}) : 4.5 to 5.5V
- Driver supply voltage (V_{DISP}) : 8 to 18V
- Duplex/Triplex (1/2 duty / 1/3 duty) selectable
 DUP/TRI=1/2 duty selectable at "H" level
 DUP/TRI=1/3 duty selectable at "L" level
- Number of display segments
 Max. 64-segment display (during 1/2 duty mode)
 Max. 96-segment display (during 1/3 duty mode)
- Master/Slave selectable
 M/\bar{S} =Master mode selectable at "H" level
 M/\bar{S} =Slave mode selectable at "L" level
- Interface with a microcontroller
 Three lines: CS, CLOCK, and DATA IN
- 32-segment driver outputs : $I_{OH}=-5mA$ at $V_{OH}=V_{DISP}-0.8V$ (SEG1 to 22)
 (can be directly connected to VFD tube : $I_{OH}=-10mA$ at $V_{OH}=V_{DISP}-0.8V$ (SEG23 to 32)
 and require no external resistors) : $I_{OL}=500\mu A$ at $V_{OL}=2V$ (SEG1 to 32)
- 3-grid pre-driver outputs : $I_{OH}=-5.0mA$ at $V_{OH}=V_{DISP}-0.8V$
 (require external drivers) : $I_{OL}=10mA$ at $V_{OL}=2V$
- Logic outputs : $I_{OH}=-200\mu A$ at $V_{OH}=V_{DD}-0.8V$
 : $I_{OL}=200\mu A$ at $V_{OL}=0.8V$
- Built-in digital dimming circuit (10-bit resolution)
- Built-in oscillation circuit (external R and C)
- Built-in Power-On-Reset circuit
- Package options:

56-pin plastic QFP (QFP56-P-910-0.65-2K)	Product name: MSM9210GS-2K
64-pin plastic QFP (QFP64-P-1414-0.80-BK)	Product name: MSM9210GS-BK

BLOCK DIAGRAM

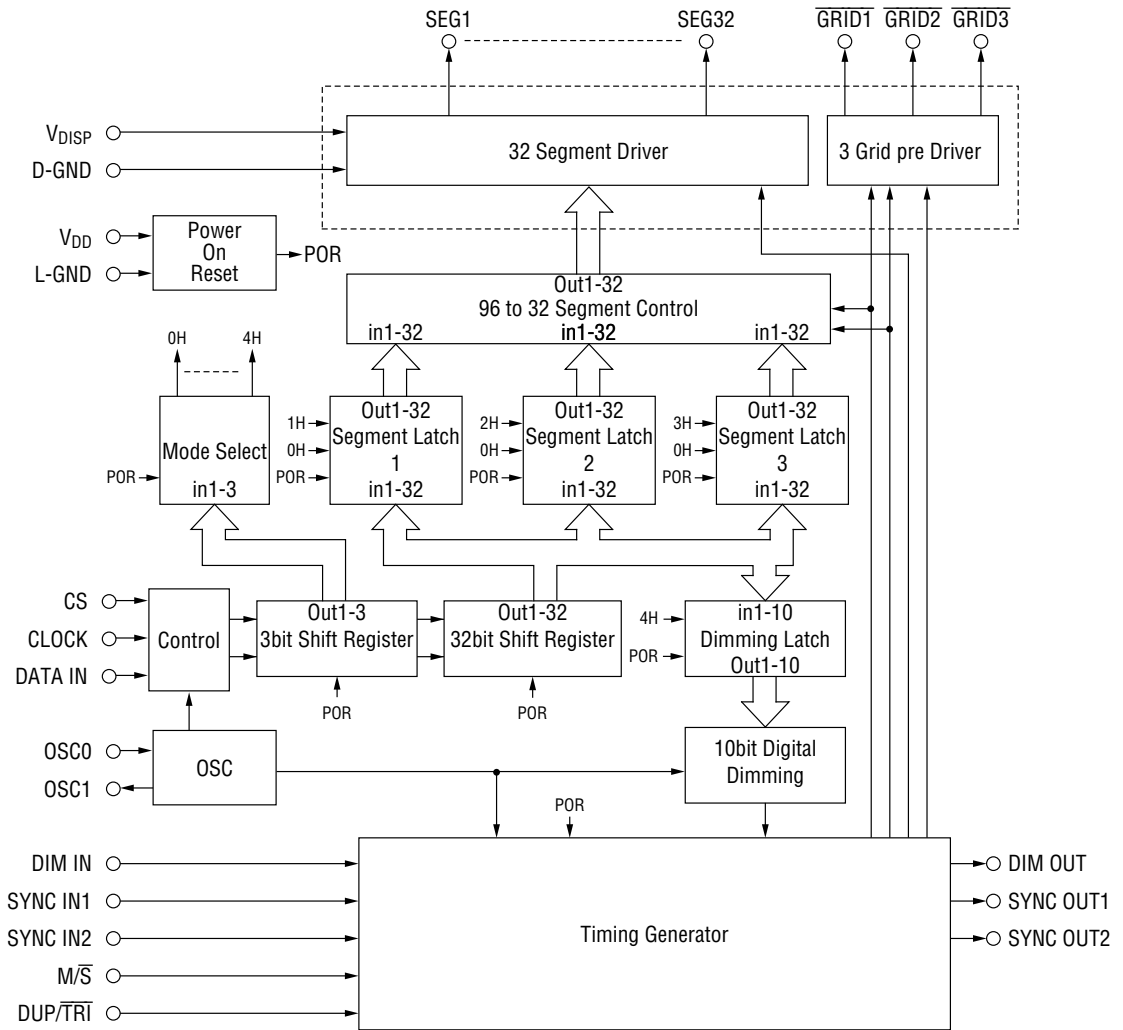

INPUT AND OUTPUT CONFIGURATION

Schematic Diagram of Driver Output Circuit

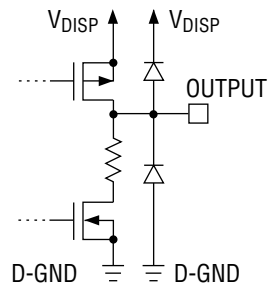

PIN CONFIGURATION (TOP VIEW)

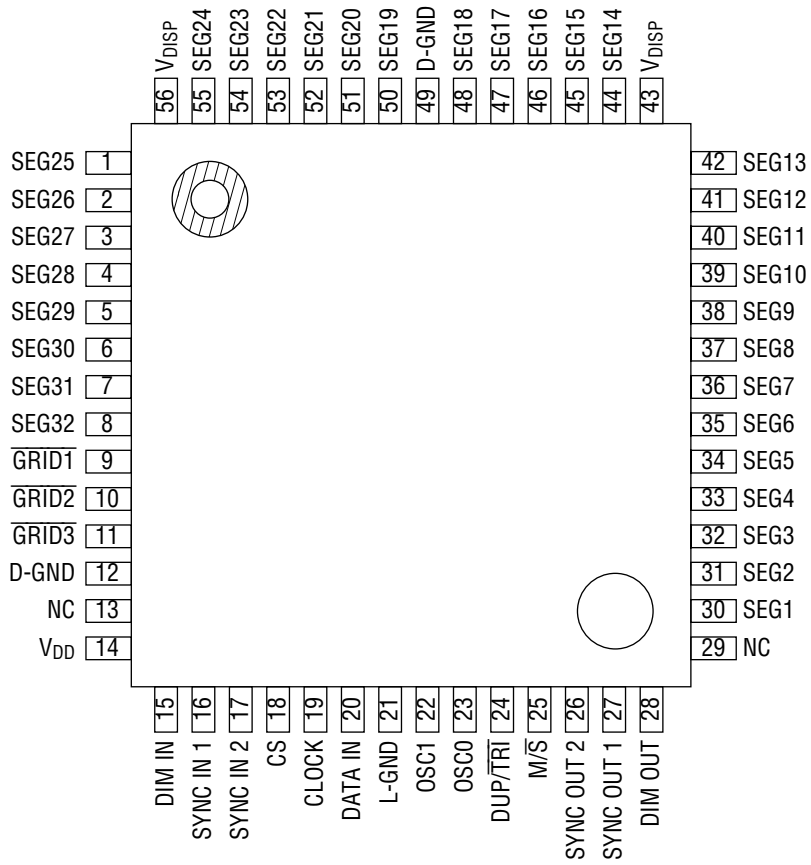

NC: No connection

56-pin Plastic QFP

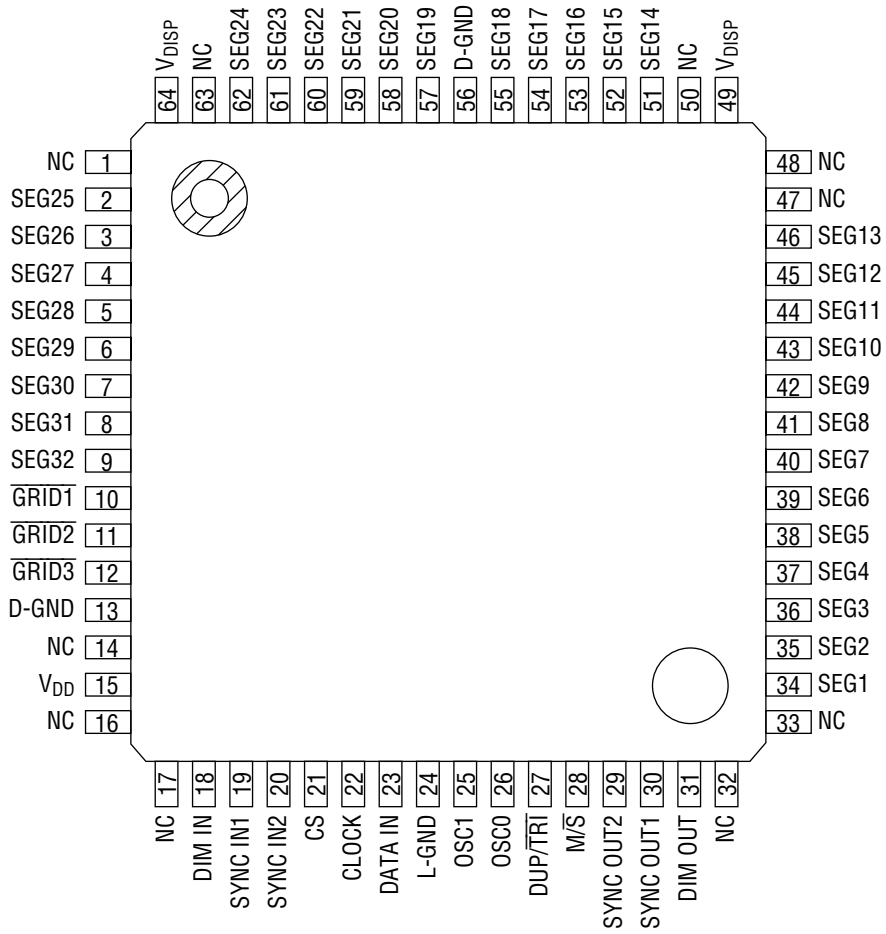

NC: No connection

64-pin Plastic QFP

PIN DESCRIPTIONS

Symbol	Pin		Type	Description
	QFP56	QFP64		
V _{DISP}	43,56	49,64	—	Power supply pins for VFD driver circuit. 43 pin and 56 pin should be connected externally.
V _{DD}	14	15	—	Power supply pin for logic drive.
D-GND	12, 49	13, 56	—	D-GND is ground pin for the VFD driver circuit. L-GND is ground pin for the logic circuit. 12pin, 21 pin and 49pin should be connected externally.
L-GND	21	24	—	
SEG1 to 22	30 to 42, 44 to 48, 50 to 53	34 to 46, 51 to 55, 57 to 60	0	Segment (anode) signal output pins for a VFD tube. These pins can be directly connected to the VFD tube. External circuit is not required. IOH≤-5 mA
SEG23 to 32	1 to 8, 54, 55	2 to 9, 61, 62	0	Segment (anode) signal output pins for a VFD tube. These pins can be directly connected to the VFD tube. External circuit is not required. IOH≤-10 mA
$\overline{\text{GRID1 to 3}}$	9, 10, 11	10, 11, 12	0	Inverted Grid signal output pins. For pre-driver, the external circuit is required. IOL≤10 mA
CS	18	21	I	Chip select input pin. Data is not transferred when CS is set to a Low level.
CLOCK	19	22	I	Shift clock input pin. Serial data shifts at the rising edge of the CLOCK.
DATA IN	20	23	I	Serial data input pin (positive logic). Data is input to the shift register at the rising edge of the CLOCK signal.
DUP/ $\overline{\text{TRI}}$	24	27	I	Duplex/Triplex operation select input pin. Duplex (1/2 duty) operation is selected when this pin is set to V _{DD} . Triplex (1/3 duty) operation is selected when this pin is set to L-GND.
M/ $\overline{\text{S}}$	25	28	I	Master/Slave mode select input pin. Master mode is selected when this pin is set to V _{DD} . Slave mode is selected when this pin is set to L-GND.
DIM IN	15	18	I	Dimming pulse input. When the slave mode is selected, the pulse width of the all segment output are controlled by a input pulse width of DIM IN. Connect this pin to the master side DIM OUT pin at the slave mode. When the master mode is selected, the input level of this pin is ignored and the pulse width of the all grids and segment outputs are controlled by a built-in 10-bit dimming circuit. Connect this pin to V _{DD} or L-GND at the master mode.

Symbol	Pin		Type	Description
	QFP56	QFP64		
SYNC IN 1, 2	16, 17	19, 20	I	Synchronous signal input. When the slave mode is selected, connect these pins to the master side SYNC OUT 1, and 2 pins. When the master mode is selected, the input level of these pins are ignored. Connect these pins to V _{DD} or L-GND at the master mode.
DIM OUT	28	31	O	Dimming pulse output. Connect this pin to the slave side DIM IN pin.
SYNC OUT 1, 2	26, 27	29, 30	O	Synchronous signal output. Connect these pins to the slave side SYNC IN 1, and 2 pins.
OSC0	23	26	I	RC oscillator connecting pins. Oscillation frequency depends on display tubes to be used. For details, refer to ELECTRICAL CHARACTERISTICS.
OSC1	22	25	O	

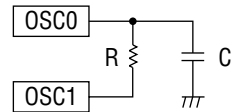

ABSOLUTE MAXIMUM RATING

Parameter	Symbol	Condition	Ratings	Unit
Driver Supply Voltage	V _{DISP}	—	-0.3 to +20	V
Logic Supply Voltage	V _{DD}	—	-0.3 to +6.5	V
Input Voltage	V _{IN}	—	-0.3 to V _{DD} +0.3	V
Power Dissipation	P _D	T _a ≥25°C	360	mW
Storage Temperature	T _{STG}	—	-55 to +150	°C
Output Current	I _{O1}	SEG1 to 22	-10.0 to +2.0	mA
	I _{O2}	SEG23 to 32	-20.0 to +2.0	mA
	I _{O3}	GRID1 to 3	-10.0 to +20.0	mA
	I _{O4}	DIM OUT, SYNC OUT1, SYNC OUT2	-2.0 to +2.0	mA

RECOMMENDED OPERATING CONDITIONS

Parameter	Symbol	Condition	Min.	Typ.	Max.	Unit
Driver Supply Voltage	V _{DISP}	—	8.0	13.0	18.0	V
Logic Supply Voltage	V _{DD}	—	4.5	5.0	5.5	V
High Level Input Voltage	V _{IH}	All inputs except OSC0	0.8V _{DD}	—	—	V
Low Level Input Voltage	V _{IL}	All inputs except OSC0	—	—	0.2V _{DD}	V
Clock Frequency	f _C	—	—	—	1.0	MHz
Operating Temperature	T _{OP}	—	-40	—	+85	°C

When a 1/2 duty VFD tube is used

Parameter	Symbol	Condition	Min.	Typ.	Max.	Unit
Oscillation Frequency	f _{OSC}	R=8.2KΩ±5%, C=22pF±5%	1.0	1.5	2.0	MHz
Frame Frequency	f _{FR}	R=8.2KΩ±5%, C=22pF±5%	122	183	244	Hz

When a 1/3 duty VFD tube is used

Parameter	Symbol	Condition	Min.	Typ.	Max.	Unit
Oscillation Frequency	f _{OSC}	R=6.2KΩ±5%, C=22pF±5%	1.5	2.25	3.0	MHz
Frame Frequency	f _{FR}	R=6.2KΩ±5%, C=22pF±5%	122	183	244	Hz

ELECTRICAL CHARACTERISTICS

DC Characteristics

Ta=-40 to +85°C, V_{DISP} =8.0 to 18.0V, V_{DD}=4.5 to 5.5V

Parameter	Symbol	Applied pin	Condition	Min.	Max.	Unit	
High Level Input Voltage	V _{IH}	*1)	—	0.8V _{DD}	—	V	
Low Level Input Voltage	V _{IL}	*1)	—	—	0.2V _{DD}	V	
High Level Input Current	I _{IH}	*1)	V _{IH} =V _{DD}	-1.0	+1.0	μA	
Low Level Input Current	I _{IL}	*1)	V _{IL} =GND	-1.0	+1.0	μA	
High Level Output Voltage	V _{OH1}	SEG1-22	V _{DISP} =9.5V	I _{OH1} =-5mA	V _{DISP} -0.8	—	V
	V _{OH2}	SEG23-32		I _{OH2} =-10mA	V _{DISP} -0.8	—	V
	V _{OH3}	GRID1-3		I _{OH3} =-5mA	V _{DISP} -0.8	—	V
	V _{OH4}	*2)	V _{DD} =4.5V	I _{OH4} =-200μA	V _{DD} -0.8	—	V
Low Level Output Voltage	V _{OL1}	SEG1-22	V _{DISP} =9.5V	I _{OL1} =500μA	—	2.0	V
	V _{OL2}	SEG23-32		I _{OL2} =500μA	—	2.0	V
	V _{OL3}	GRID1-3		I _{OL3} =10mA	—	2.0	V
	V _{OL4}	*2)	V _{DD} =4.5V	I _{OL4} =200μA	—	0.8	V
Supply Current	I _{DISP}	V _{DISP}	f _{OSC} =3.0MHz, no load	—	100	μA	
	I _{DD}	V _{DD}	f _{OSC} =3.0MHz, no load	—	5.0	mA	

*1) CS, CLOCK, DATA IN, DIM IN, SYNC IN 1, SYNC IN 2, M/ \bar{S} , DUP/ \overline{TRI}

*2) DIM OUT, SYNC OUT 1, SYNC OUT 2

AC Characteristics

$T_a = -40$ to $+85^\circ\text{C}$, $V_{\text{DISP}} = 8.0$ to 18.0V , $V_{\text{DD}} = 4.5$ to 5.5V

Parameter	Symbol	Condition	Min.	Max.	Unit	
Clock Frequency	f_c	—	—	1.0	MHz	
Clock Pulse Width	t_{CW}	—	400	—	ns	
Data Setup Time	t_{DS}	—	400	—	ns	
Data Hold Time	t_{DH}	—	400	—	ns	
CS Off Time	t_{CSL}	—	20	—	μs	
CS Setup Time (CS-Clock)	t_{CSS}	—	400	—	ns	
CS Hold Time (Clock-CS)	t_{CSH}	—	400	—	ns	
CS Wait Time	t_{RSOFF}	—	400	—	μs	
Output Slew Rate Time	t_{R}	$C_L = 100\text{pF}$	$t_{\text{R}} = 20\%$ to 80%	—	2.0	μs
	t_{F}		$t_{\text{F}} = 80\%$ to 20%	—	2.0	μs
V_{DD} Rise Time	t_{PRZ}	Mounted in a unit	—	100	μs	
V_{DD} Off Time	t_{POF}	Mounted in a unit, $V_{\text{DD}} = 0.0\text{V}$	5.0	—	ms	

TIMING DIAGRAM

● **Data Input Timing**

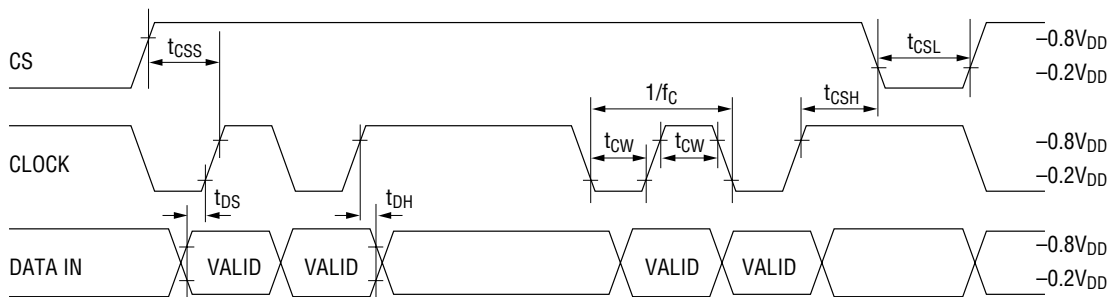

● **Reset Timing**

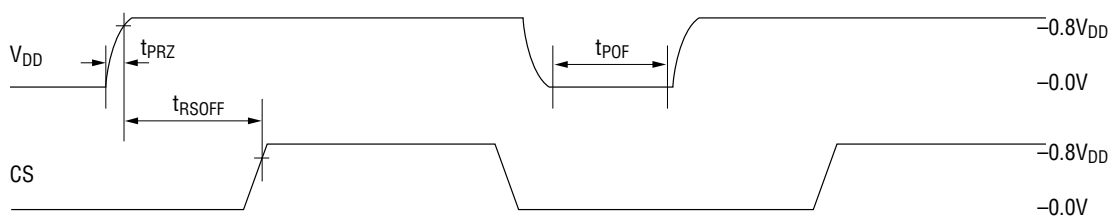

● **Driver Output Timing**



● **Output Timing (Duplex Operation)** *1bit time=4/f_{OSC}
 (The dimming data is 1016/1024 at the master mode)

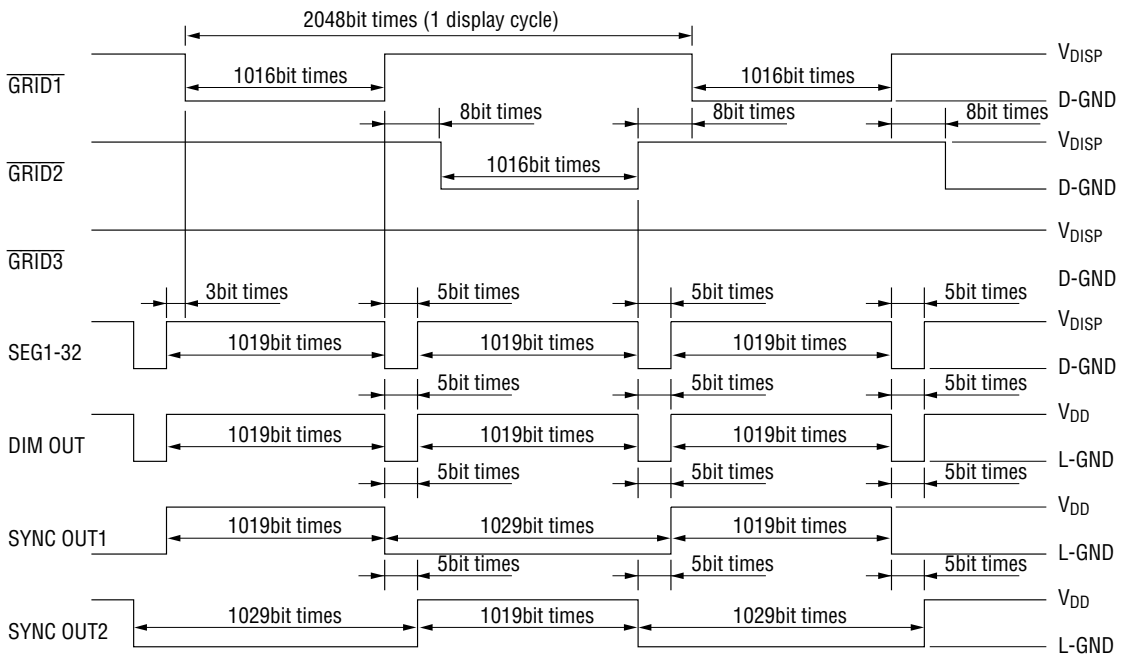

● **Output Timing (Triplex Operation)** *1bit time=4/f_{OSC}
 (The dimming data is 1016/1024 at the master mode)

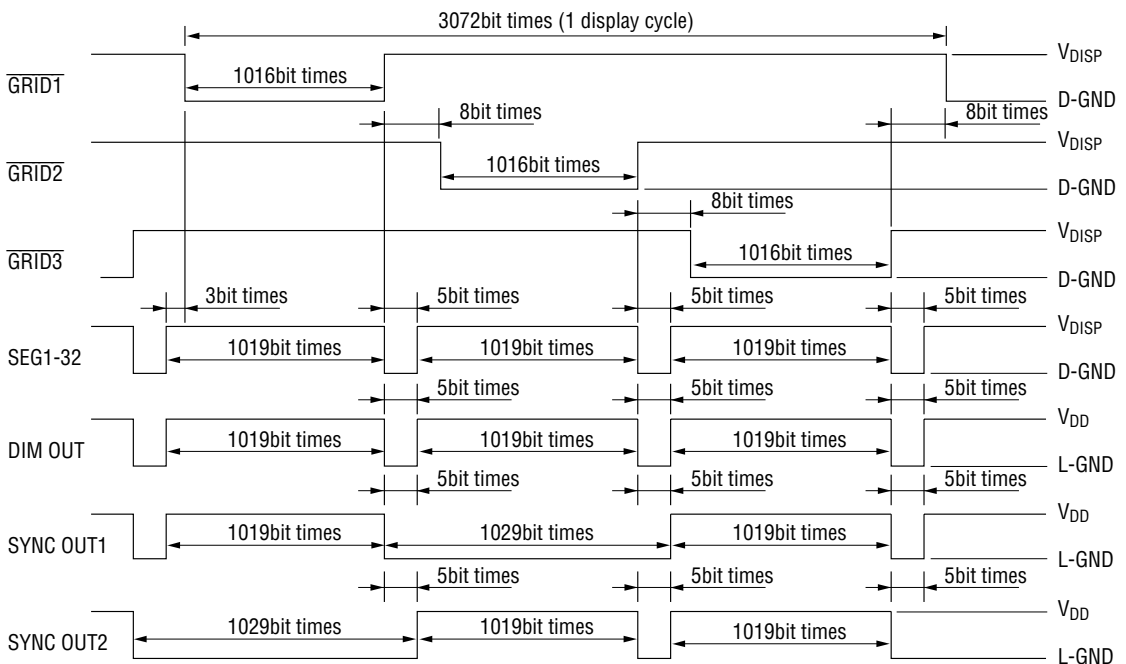

FUNCTIONAL DESCRIPTION

Power-on Reset

When power is turned on, MSM9210 is initialized by the internal power-on reset circuit.

The status of the internal circuit after initialization is as follows:

- The contents of the shift registers and latches are set to "0".
- The digital dimming duty cycle is set to "0".
- All segment outputs are set to Low level.
- All grid outputs are set to High level.

Data Transfer Method

Data can be transferred between the rising edge and the next falling edge of chip select input. The mode data, segment data and dimming data are written by a serial transfer method. The serial data is input to the shift register at the rising edge of a shift clock pulse.

The mode data (M0 to M2) must be transferred after the segment data and dimming data succeedingly.

When the chip select input falls, an internal LOAD signal is automatically generated and data is loaded to the latches.

Function Mode

Function mode is selected by the mode data (M0 to M2). The relation between function mode and mode data is as follows:

FUNCTION MODE	OPERATING MODE	FUNCTION DATA		
		M0	M1	M2
0	Segment Data for $\overline{\text{GRID1-3}}$ Input	0	0	0
1	Segment Data for $\overline{\text{GRID1}}$ Input	1	0	0
2	Segment Data for $\overline{\text{GRID2}}$ Input	0	1	0
3	Segment Data for $\overline{\text{GRID3}}$ Input	1	1	0
4	Digital Dimming Data Input	0	0	1

Segment Data Input [Function Mode: 0 to 3]

- MSM9210 receives the segment data when function mode 0 to 3 are selected.
- The same segment data is transferred to the 3 segment data latches corresponding to $\overline{\text{GRID1 to 3}}$ at the same time when the function mode 0 is selected.
- The segment data is transferred to only one segment data latch corresponding to the specified GRID when the function mode is 1, 2 or 3 is selected.
- Segment output (SEG1 to 32) becomes High level (lightning) when the segment data (S1 to S32) is set to "1".

[Data Format]

Input Data : 35 bits
 Segment Data : 32 bits
 Mode Data : 3 bits

Bit	1	2	3	4	29	30	31	32	33	34	35
Input Data	S1	S2	S3	S4	S29	S30	S31	S32	M0	M1	M2

Segment Data (32bits)

 Mode Data (3bits)

[Bit correspondence between segment output and segment data]

SEG n	1	2	3	4	5	6	7	8	9	10	11	12	13	14	15	16
Segment data	S1	S2	S3	S4	S5	S6	S7	S8	S9	S10	S11	S12	S13	S14	S15	S16
SEG n	17	18	19	20	21	22	23	24	25	26	27	28	29	30	31	32
Segment data	S17	S18	S19	S20	S21	S22	S23	S24	S25	S26	S27	S28	S29	S30	S31	S32

Digital Dimming Data Input [Function Mode: 4]

- MSM9210 receives the digital dimming data when function mode 4 is selected.
- The output duty changes in the range of 0/1024 (0%) to 1016/1024 (99.2%) for each grid.
- The 10-bit digital dimming data is input from LSB.

[Data Format]

Input Data : 13 bits
 Digital Dimming Data: 10 bits
 Mode Data : 3 bits

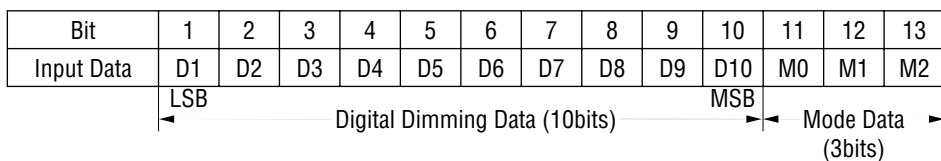

(LSB)		Dimming Data								(MSB)	Duty Cycle
D1	D2	D3	D4	D5	D6	D7	D8	D9	D10		
0	0	0	0	0	0	0	0	0	0	0	0/1024
1	0	0	0	0	0	0	0	0	0	0	1/1024
⋮											
1	1	1	0	1	1	1	1	1	1	1	1015/1024
0	0	0	1	1	1	1	1	1	1	1	1016/1024
1	0	0	1	1	1	1	1	1	1	1	1016/1024
⋮											
1	1	1	1	1	1	1	1	1	1	1	1016/1024

Master Mode

Master Mode is selected when M/S pin is set at High level. The master mode operation is as follows:

- The input levels of DIM IN, SYNC IN1 and SYNC IN2 are ignored, and these pins should be connected to L-GND or V_{DD}.
- The pulse width of GRID1 to 3 and SEG1 to 32 are controlled by the internal digital dimming circuit.
- The segment Latch1 to 3 corresponding to $\overline{\text{GRID1 to 3}}$ are selected by the internal timing generator.

Slave Mode

Slave Mode is selected when M/ \bar{S} pin is set at Low level. The slave mode operation is as follows:

- The internal dimming circuit is ignored.
- The pulse width of SEG1 to 32 are controlled by the pulse width of DIM IN signal.
- The segment Latch1 to 3 corresponding to $\overline{\text{GRID1 to 3}}$ are selected by SYNC IN1 and SYNC IN2 signals.
- The output levels of $\overline{\text{GRID1 to 3}}$ are set at High level. The output levels of DIM OUT, SYNC OUT1 and SYNC OUT2 are set at Low level.

[Correspondence between SYNC IN1, 2 and Segment Latch1 to 3]

SYNC IN 1	SYNC IN 2	Segment Latch	GRID
0	0	No	No
1	0	Latch1	$\overline{\text{GRID1}}$
0	1	Latch2	$\overline{\text{GRID2}}$
1	1	Latch3	$\overline{\text{GRID3}}$

[Correspondence between DIM IN and SEG1 to 32]

DIM IN	SEG1 to 32
0	Low
1	High

Note: Low: Lights OFF
High: Lights ON

APPLICATION CIRCUITS

1. Circuit for the duplex VFD tube with 128 segments (2 Grid × 64 Anode)

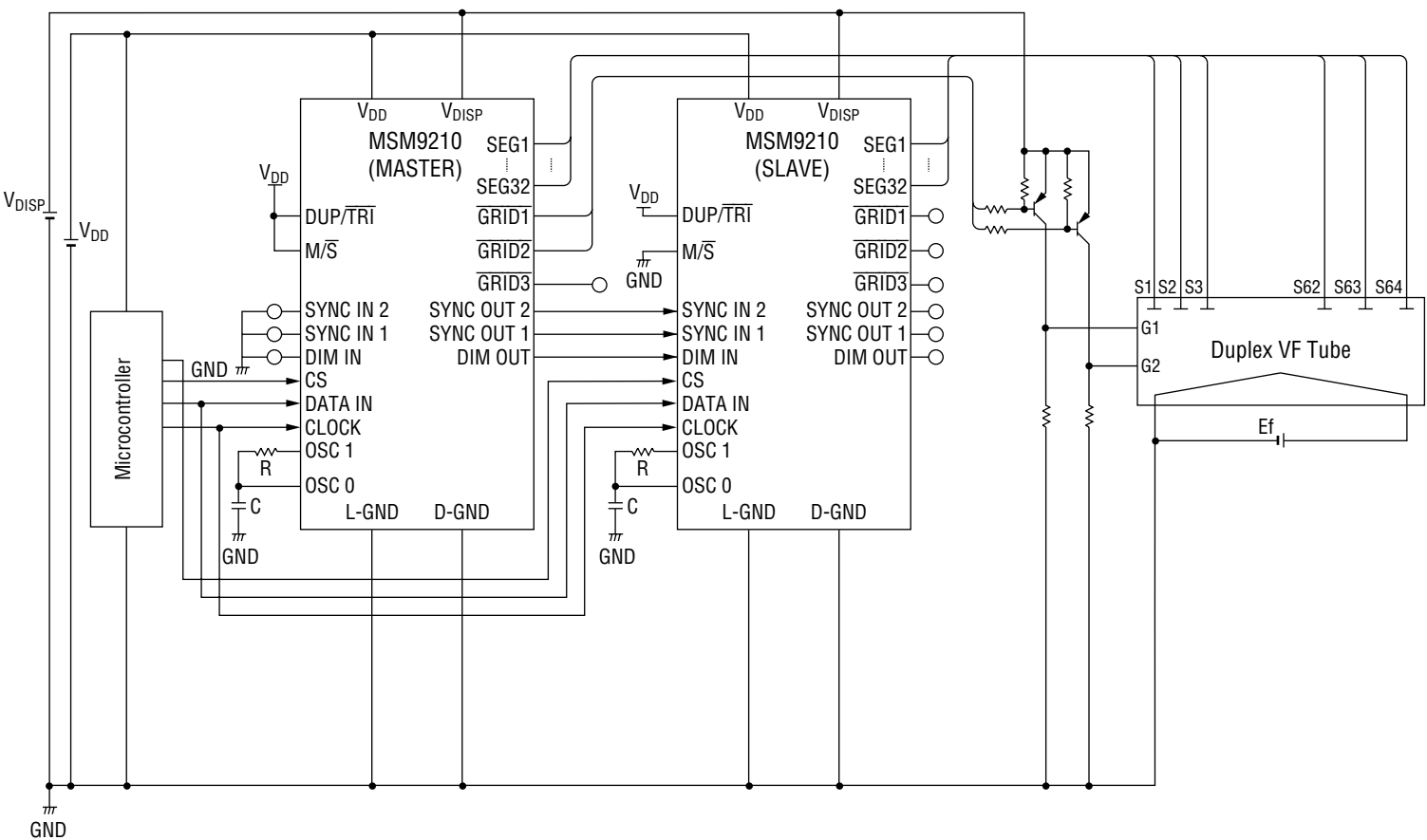

2. Circuit for the triplex VFD tube with 192 segments (3 Grid × 64 Anode)

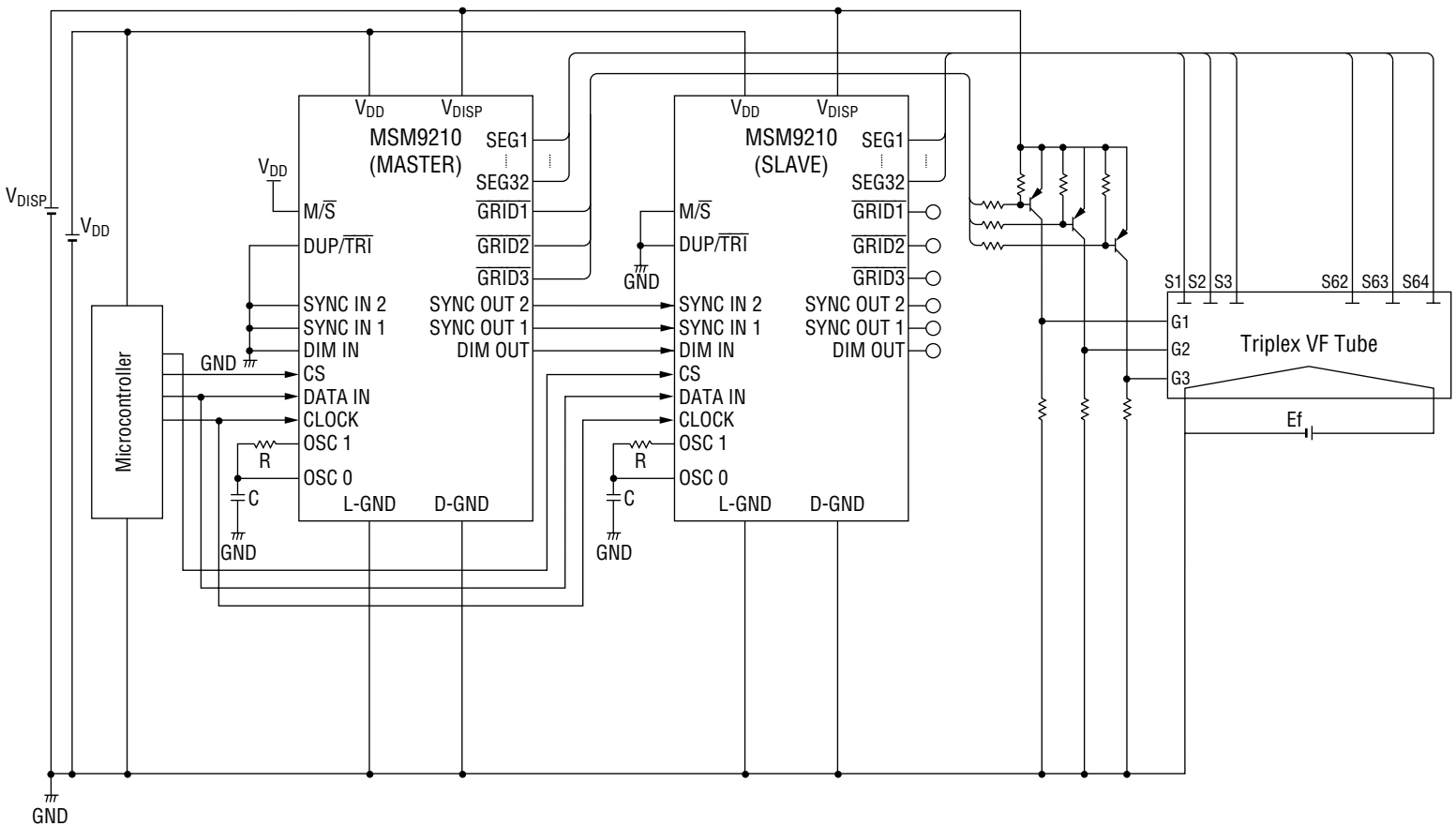

NOTES ON TURNING POWER ON/OFF

- Connect L-GND and D-GND externally to be an equal potential voltage.
- To avoid wrong operations, turn on the driver power supply after turning on the logic power supply. Conversely, turn off the logic power supply after tuning off the driver power supply.

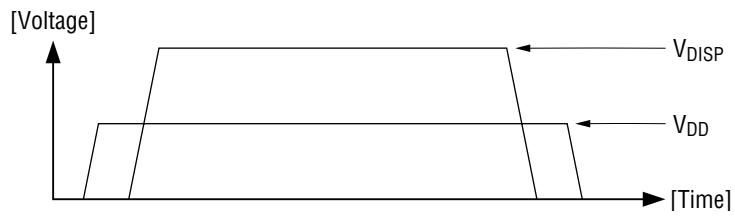

PACKAGE DIMENSIONS

(Unit : mm)

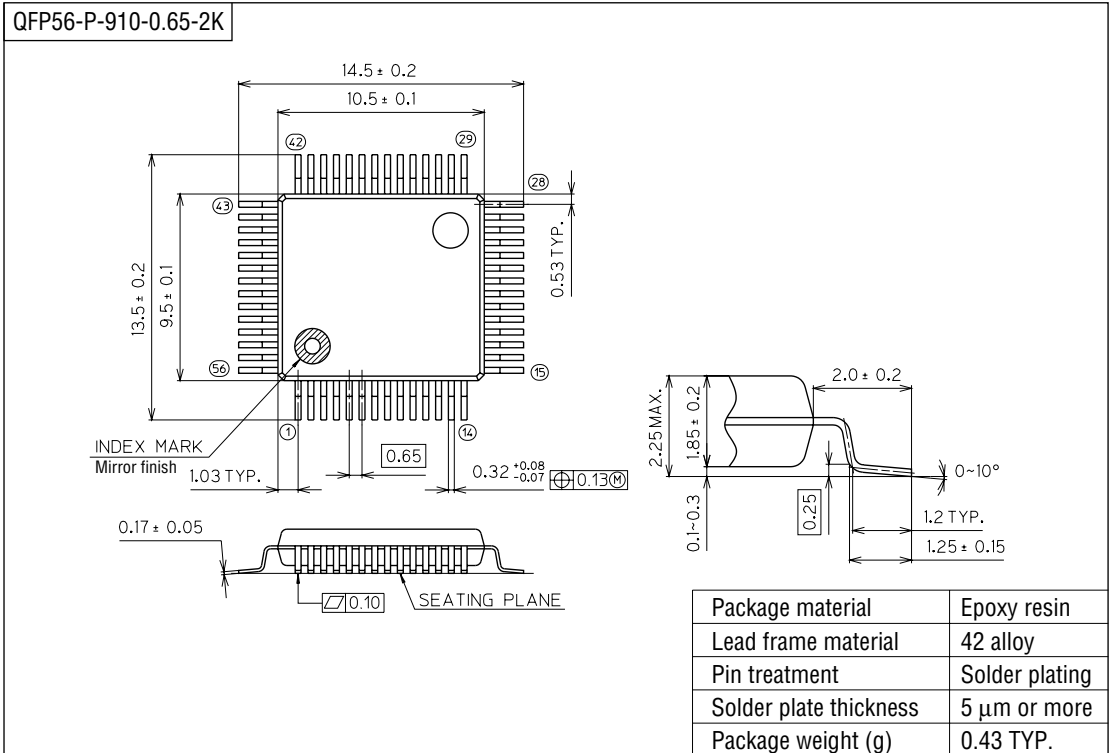

Notes for Mounting the Surface Mount Type Package

The SOP, QFP, TSOP, SOJ, QFJ (PLCC), SHP and BGA are surface mount type packages, which are very susceptible to heat in reflow mounting and humidity absorbed in storage. Therefore, before you perform reflow mounting, contact Oki's responsible sales person for the product name, package name, pin number, package code and desired mounting conditions (reflow method, temperature and times).

(Unit : mm)

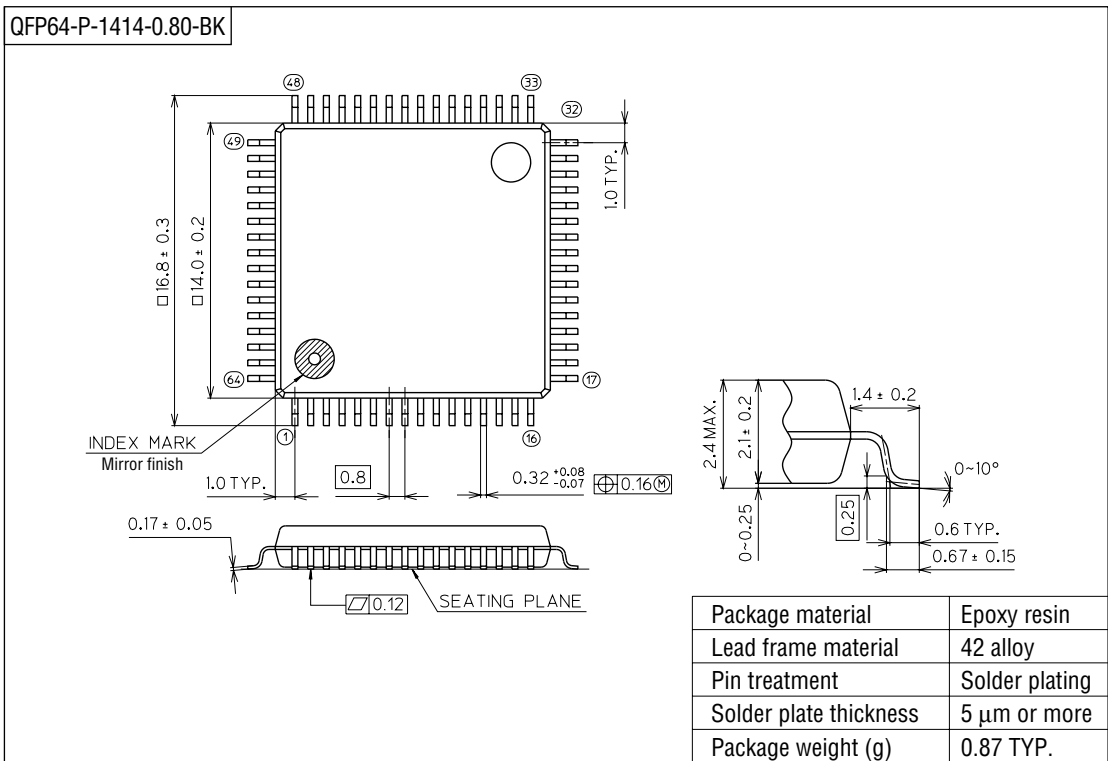

Notes for Mounting the Surface Mount Type Package

The SOP, QFP, TSOP, SOJ, QFJ (PLCC), SHP and BGA are surface mount type packages, which are very susceptible to heat in reflow mounting and humidity absorbed in storage. Therefore, before you perform reflow mounting, contact Oki's responsible sales person for the product name, package name, pin number, package code and desired mounting conditions (reflow method, temperature and times).

NOTICE

1. The information contained herein can change without notice owing to product and/or technical improvements. Before using the product, please make sure that the information being referred to is up-to-date.
2. The outline of action and examples for application circuits described herein have been chosen as an explanation for the standard action and performance of the product. When planning to use the product, please ensure that the external conditions are reflected in the actual circuit, assembly, and program designs.
3. When designing your product, please use our product below the specified maximum ratings and within the specified operating ranges including, but not limited to, operating voltage, power dissipation, and operating temperature.
4. Oki assumes no responsibility or liability whatsoever for any failure or unusual or unexpected operation resulting from misuse, neglect, improper installation, repair, alteration or accident, improper handling, or unusual physical or electrical stress including, but not limited to, exposure to parameters beyond the specified maximum ratings or operation outside the specified operating range.
5. Neither indemnity against nor license of a third party's industrial and intellectual property right, etc. is granted by us in connection with the use of the product and/or the information and drawings contained herein. No responsibility is assumed by us for any infringement of a third party's right which may result from the use thereof.
6. The products listed in this document are intended for use in general electronics equipment for commercial applications (e.g., office automation, communication equipment, measurement equipment, consumer electronics, etc.). These products are not authorized for use in any system or application that requires special or enhanced quality and reliability characteristics nor in any system or application where the failure of such system or application may result in the loss or damage of property, or death or injury to humans. Such applications include, but are not limited to, traffic and automotive equipment, safety devices, aerospace equipment, nuclear power control, medical equipment, and life-support systems.
7. Certain products in this document may need government approval before they can be exported to particular countries. The purchaser assumes the responsibility of determining the legality of export of these products and will take appropriate and necessary steps at their own expense for these.
8. No part of the contents contained herein may be reprinted or reproduced without our prior permission.
9. MS-DOS is a registered trademark of Microsoft Corporation.

Copyright 1999 Oki Electric Industry Co., Ltd.