

### Description

The GM6155 is an efficient linear voltage regulator with ultralow - noise output, very low dropout voltage (typically 17mV at light loads and 100mV at 50mA), and very low ground current (600µA at 100mA output). The GM6155 provides better than 1% initial accuracy.

Designed especially for hand-held, battery-powered devices, the GM6155 includes a CMOS or TTL compatible enable/ shutdown control input. When shutdown, power consumption drops nearly to zero. Regulator ground current increases only slightly in dropout, further prolonging battery life. Key GM6155 features include a reference bypass pin to improve its already excellent low-noise performance, reversed-battery protection, current limiting, and overtemperature shutdown.

The GM6155 is available in SOT-25 package.

### Features

- ◆ Very low noise output
- ◆ Extremely accurate output voltage
- ◆ Guaranteed 150mA output
- ◆ Low quiescent current
- ◆ Low dropout voltage
- ◆ Extremely tight load and line regulation
- ◆ Very low temperature coefficient
- ◆ Current and thermal limiting
- ◆ Reverse-battery protection
- ◆ "Zero" off-mode current
- ◆ Logic-controlled electronic enable

### Application

Cellular telephones

Laptop, notebook, and palmtop computers

Battery-powered equipment

PCMCIA  $V_{CC}$  and  $V_{PP}$  regulation/ switching

Consumer/ personal electronics

SMPS post-regulator/ dc-to-dc modules

High-efficiency linear power supplies

### TYPICAL APPLICATION CIRCUITS

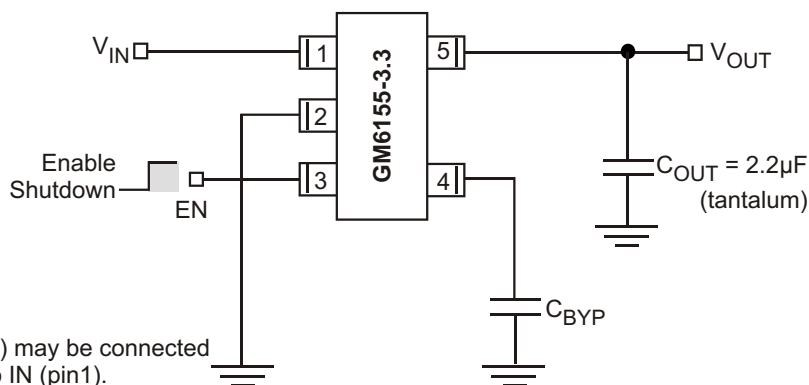

EN (pin 3) may be connected directly to IN (pin1).

Low-Noise Operation:  
 $C_{BYP} = 470\text{pF}$ ,  $C_{OUT} \geq 2.2\mu\text{F}$

Basic Operation:  
 $C_{BYP} = \text{not used}$ ,  $C_{OUT} \geq 1\mu\text{F}$

◆ MARKING INFORMATION & PIN CONFIGURATIONS (TOP VIEW)

SOT-25 (SOT-23-5)

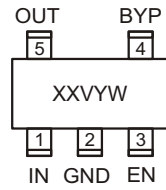

Fixed Voltages

SOT-25 (SOT-23-5)

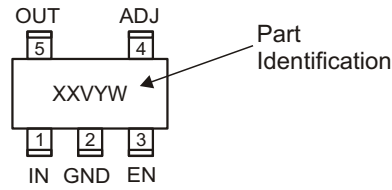

Adjustable Voltage

- XX = Specific Device Code(DA = GM6155)
- V = Voltage Code
- Y = Year
- W = Work Week

◆ ORDERING INFORMATION

Ordering Number	Output Voltage	Voltage Code	Package	Shipping
GM6155-AST25R	Adj	A	SOT-25	3,000 Units/ Tape & Reel
GM6155-2.5ST25R	2.5V	G	SOT-25	3,000 Units/ Tape & Reel
GM6155-2.7ST25R	2.7V	T	SOT-25	3,000 Units/ Tape & Reel
GM6155-2.8ST25R	2.8V	H	SOT-25	3,000 Units/ Tape & Reel
GM6155-2.9ST25R	2.9V	X	SOT-25	3,000 Units/ Tape & Reel
GM6155-3.0ST25R	3.0V	J	SOT-25	3,000 Units/ Tape & Reel
GM6155-3.3ST25R	3.3V	K	SOT-25	3,000 Units/ Tape & Reel
GM6155-3.6ST25R	3.6V	L	SOT-25	3,000 Units/ Tape & Reel
GM6155-4.0ST25R	4.0V	M	SOT-25	3,000 Units/ Tape & Reel
GM6155-4.2ST25R	4.2V	Y	SOT-25	3,000 Units/ Tape & Reel
GM6155-5.0ST25R	5.0V	Q	SOT-25	3,000 Units/ Tape & Reel

\* For detail Ordering Number identification, please see last page.

◆ PIN DESCRIPTION

Pin Number	Pin Name	Function
1	IN	Supply Input
2	GND	Ground
3	EN	Enable/ Shutdown(Input): COMS compatible input. Logic high = enable, logic low or open = shutdown.
4	BYP	Reference Bypass: Connect external 470pF capacitor to GND to reduce output noise. May be left open.
5	OUT	Regulator Output

## ◆ BLOCK DIAGRAM

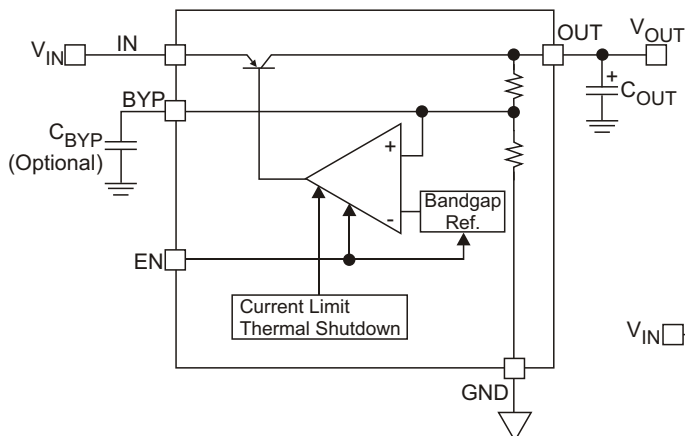

Figure 1. Ultra-Low-Noise Fixed Regulator

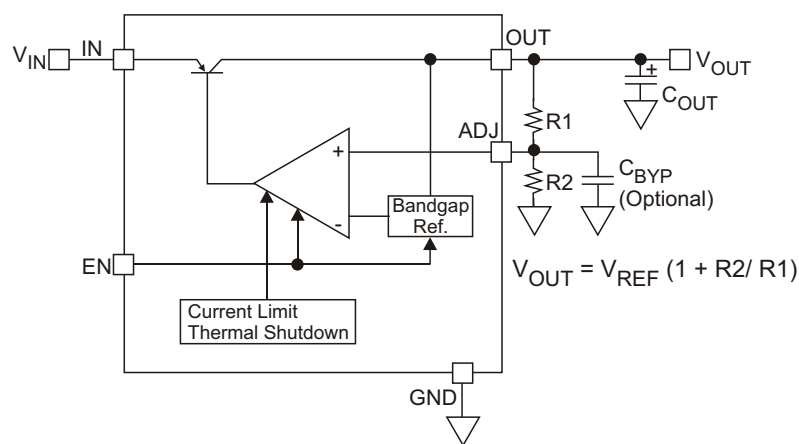

Figure 2. Ultra-Low-Noise Adjustable Regulator

## ◆ ABSOLUTE MAXIMUM RATINGS

PARAMETER	SYMBOL	RATINGS	UNITS
Supply Input Voltage	$V_{IN}$	-20 ~ +20	V
Enable Input Voltage	$V_{EN}$	-20 ~ +20	V
Power Dissipation (Note 3)	$P_D$	Internally Limited	W
Junction Temperature	$T_J$	-40 ~ +125	°C
Lead Temperature (soldering, 5 seconds)	$T_{LEAD}$	260	°C
Storage Temperature	$T_S$	-60 ~ +150	°C

## ◆ OPERATING RATINGS

PARAMETER	SYMBOL	RATINGS	UNITS
Supply Input Voltage	$V_{IN}$	+2.5 to +16	V
Enable Input Voltage	$V_{EN}$	0 to $V_{IN}$	V
Junction Temperature	$T_J$	-40 ~ +125	°C
Thermal Resistance	$J_A$	(Note 3)	°C/W

## ◆ ELECTRICAL CHARACTERISTICS

( $V_{IN} = V_{OUT} + 1V$ ;  $I_L = 100\mu A$ ;  $C_L = 1.0\mu F$ ;  $V_{EN} \geq 2.0$ ;  $T_J = 25^\circ C$ , **bold** values indicate  $-40^\circ C \leq T_J \leq +125^\circ C$ ; unless otherwise noted)

Parameter	Symbol	Test Condition	Min	Typ	Max	Unit
Output Voltage Accuracy	$V_O$	Variation from specified $V_{OUT}$	-1 -2		1 2	%
Output Voltage Temperature Coefficient	$V_O / T$	(Note 4)		<b>100</b>		ppm/°C
Line Regulation	$V_O / V_O$	$V_{IN} = V_{OUT} + 1V$ to 16V		0.004	0.012/ <b>0.05</b>	%/V
Load Regulation	$V_O / V_O$	$I_L = 0.1mA$ to 150mA, (Note 5)		0.02	0.2/ <b>0.5</b>	%/V
Dropout Voltage (Note 6)	$V_{IN} - V_O$	$I_L = 100\mu A$		10	50	mV
		$I_L = 50mA$		110	150	
		$I_L = 100mA$		140	250	
		$I_L = 150mA$		165	275	
Quiescent Current	$I_{GND}$	$V_{EN} \leq 0.4V$ (shutdown)		0.01	1	$\mu A$
		$V_{EN} \leq 0.18V$ (shutdown)			<b>5</b>	
Ground Pin Current (Note 7)	$I_{GND}$	$V_{EN} \geq 2.0V$ , $I_L = 0.1mA$		80	125	$\mu A$
		$I_L = 50mA$		350	600	
		$I_L = 100mA$		600	1000	
		$I_L = 150mA$		1300	1900	
Ripple Rejection	PSRR	$f = 100Hz$ , $I_L = 0.1mA$		75		dB
Current Limit	$I_{LIMIT}$	$V_{OUT} = 0V$		<b>320</b>	500	mA
Thermal Regulation	$V_O / P_D$	(Note 8)		0.05		%/W
Output Noise	$e_{NO}$	$I_L = 50mA$ , $C_L = 2.2\mu F$ , 470pF from BYP to GND		260		nV/ $\sqrt{Hz}$
<b>ENABLE Input</b>						
Enable Input Logic-Low Voltage	$V_{IL}$	Regulator shutdown			0.4 <b>0.18</b>	V
Enable Input Logic-High Voltage	$V_{IH}$	Regulator enabled	<b>2.0</b>			V
Enable Input Current	$I_{IL}$	$V_{IL} \leq 0.4V$ $V_{IL} \leq 0.18V$		0.01	-1 -2	$\mu A$
	$I_{IH}$	$V_{IH} \leq 2.0V$	2	5	20 <b>25</b>	$\mu A$

**Note 1.** Exceeding the absolute maximum rating may damage the device.

**Note 2.** The device is not guaranteed to function outside its operating rating.

**Note 3:** The maximum allowable power dissipation at any  $T_A$  (ambient temperature) is  $P_D(max) = (T_J(max) - T_A) \div \theta_{JA}$ . Exceeding the maximum allowable power dissipation will result in excessive die temperature, and the regulator will go into thermal shutdown.

**Note 4:** Output voltage temperature coefficient is defined as the worst case voltage change divided by the total temperature range.

**Note 5:** Regulation is measured at constant junction temperature using low duty cycle pulse testing. Parts are tested for load regulation in the load range from 0.1mA to 150mA. Changes in output voltage due to heating effects are covered by the thermal regulation specification.

**Note 6:** Dropout Voltage is defined as the input to output differential at which the output voltage drops 2% below its nominal value measured at 1V differential.

**Note 7:** Ground pin current is the regulator quiescent current plus pass transistor base current. The total current drawn from the supply is the sum of the load current plus the ground pin current.

**Note 8:** Thermal regulation is defined as the change in output voltage at a time "t" after a change in power dissipation is applied, excluding load or line regulation effects. Specifications are for a 150mA load pulse at  $V_{IN} = 16V$  for  $t = 10ms$ .

## ◆ Applications Information

### Enable/ Shutdown

Forcing EN (enable/ shutdown) high (>2V) enables the regulator. EN is compatible with CMOS logic gates. If the enable / shutdown feature is not required, connect EN (pin 3) to IN (supply input, pin 1). See Figure 3.

### Input Capacitor

A 1 $\mu$ F capacitor should be placed from IN to GND if there is more than 10 inches of wire between the input and the acfilter capacitor or if a battery is used as the input .

### Reference Bypass Capacitor

BYP (reference bypass) is connected to the internal voltage reference. A 470pF capacitor ( $C_{BYP}$ ) connected from BYP to GND quiets this reference, providing a significant reduction in output noise.  $C_{BYP}$  reduces the regulator phase margin; when using  $C_{BYP}$ , output capacitors of 2.2 $\mu$ F or greater are generally required to maintain stability.

The start-up speed of the GM6155 is inversely proportional to the size of the reference bypass capacitor. Applications requiring a slow ramp-up of output voltage should consider larger values of  $C_{BYP}$ . Likewise, if rapid turn-on is necessary, consider omitting  $C_{BYP}$ .

If output noise is not a major concern, omit  $C_{BYP}$  and leave BYP open.

### Output Capacitor

An output capacitor required between OUT and GND to prevent oscillation. The minimum size of the output capacitor is dependent upon whether a reference bypass capacitor is used. 1.0 $\mu$ F minimum is recommended when  $C_{BYP}$  is not used (see Figure 2). 2.2 $\mu$ F minimum is recommended when  $C_{BYP}$  is 470pF (see Figure 1). Larger values improve the regulator's transient response. The output capacitor value may be increased without limit.

The output capacitor is should have an ESR (effective series resistance) of about 5  $\Omega$  or less and a resonant frequency above 1MHz. Ultra-low-ESR capacitors can cause a low amplitude oscillation on the output and/ or underdamped transient response. Most tantalum or aluminum electrolytic capacitors are adequate; film types will work, but are more expensive. Since many aluminum electrolytics have electrolytes that freeze at about -30°C, solid tantalums ate recommended for operation below -25°C.

At lower values for output current, less output capacitance is required for output stability. The capacitor can be reduced to 0.47 $\mu$ F for current below 10mA or 0.33 $\mu$ F for current below 1mA.

### No-Load Stability

The GM6155 will remain stable and in regulation with no load (other than the internal voltage divider) unlike many other voltage regulators. This is especially important in CMOS RAM keep-alive applications.

### Thermal Considerations

The GM6155 is designed to provide 150mA of continuous current in a very small package. Maximum power dissipation can be calculated based on the output current and the voltage drop across the part. To determine the maximum power dissipation of the package, use the junction-to-ambient thermal resistance of the device and the following basic equation:

$$P_{D(max)} = \frac{(T_{J(max)} - T_A)}{R_{JA}}$$

$T_{J(max)}$  is the maximum junction temperature of the die, 125°C, and  $T_A$  is the ambient operating temperature.  $R_{JA}$  is layout dependent; Table 1 shows examples of junction-to-ambient thermal resistance for the GM6155.

Parameter	R <sub>JA</sub> Recommended Minimum Footprint	R <sub>JA</sub> 1" Square Copper Clad	R <sub>JC</sub>
SOT-23-5	220°C/W	170°C/W	130°C/W

Table 1. SOT-25 Thermal Resistance

The actual power dissipation of the regulator circuit can be determined using the equation:

$$P_D = (V_{IN} - V_{OUT}) I_{OUT} + V_{IN} I_{GND}$$

Substituting P<sub>D(max)</sub> for P<sub>D</sub> and solving for the operating conditions that are critical to the application will give the maximum operating conditions for the regulator circuit. For example, when operating the GM6155 at room temperature with a minimum footprint layout, the maximum input voltage for a set output current can be determined as follows:

$$P_{D(max)} = \frac{(125^\circ\text{C} - 25^\circ\text{C})}{220^\circ\text{C/W}}$$

$$P_{D(max)} = 455\text{mW}$$

The junction-to-ambient thermal resistance for the minimum footprint is 220°C/W, from Table 1. The maximum power dissipation must not be exceeded for proper operation. Using the output voltage of 3.3V and an output current of 150mA, the maximum input voltage can be determined. From the Electrical Characteristics table, the maximum ground current for 150mA output current is 2500µA or 2.5mA.

$$455\text{mW} = (V_{IN} - 3.3\text{V}) 150\text{mA} + V_{IN} \cdot 2.5\text{mA}$$

$$455\text{mW} = V_{IN} \cdot 150\text{mA} - 495\text{mA} + V_{IN} \cdot 2.5\text{mA}$$

$$950\text{mW} = V_{IN} \cdot 152.5\text{mA}$$

$$V_{IN(max)} = 6.23\text{V}$$

Therefore, a 3.3V application at 150mA of output current can accept a maximum input voltage of 6.2V in a SOT-25 package. For a full discussion of heat sinking and thermal effects on voltage regulators.

### Fixed Regulator Applications

Figure 3. Ultra-Low-Noise Fixed Voltage Application

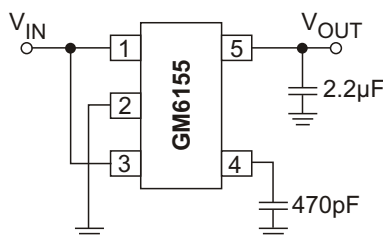

Figure 3. includes a 470pF capacitor for low-noise operation and shows EN (pin 3) connected to IN (pin 1) for an application where enable/ shutdown is not required. C<sub>OUT</sub> = 2.2µF minimum.

Figure 4. Low-Noise Fixed Voltage Application

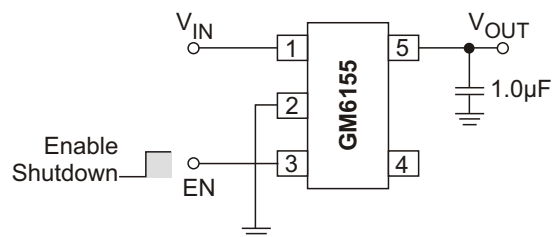

Figure 4. is an example of a low-noise configuration where C<sub>BYP</sub> is not required. C<sub>OUT</sub> = 1µF minimum.

### Adjustable Regulator Applications

The GM6155 can be adjusted to a specific output voltage by using two external resistors (Figure 5). The resistors set the output voltage based on the following equation:

$$V_{OUT} = 1.242\text{V} \times \left( \frac{R_2}{R_1} + 1 \right)$$

This equation is correct due to the configuration of the bandgap reference. The bandgap voltage is relative to the output, as seen in the block diagram. Traditional regulators normally have the reference voltage relative to ground and have a different  $V_{OUT}$  equation.

Resistor values are not critical because ADJ(adjust) has a high input impedance, but for best results use resistors of 470k or less. A capacitor from ADJ to ground provides greatly improved noise performance.

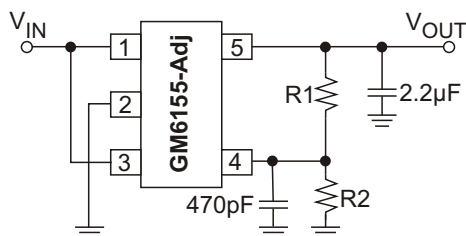

Figure 5. Ultra-Low- Noise Adjustable Voltage Application

Figure 5 includes the optional 470pF noise bypass capacitor from ADJ to GND to reduce output noise.

**Dual-Supply Operation**

When used in dual supply systems where the regulator load is returned to a negative supply, the output voltage must be diode clamped to ground.

**◆ Typical Characteristics**

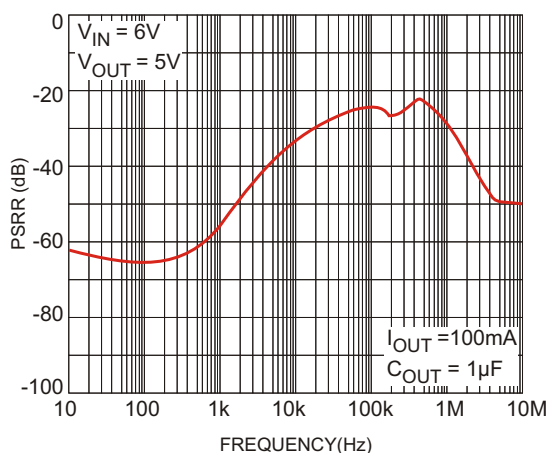

Figure 6. Power Supply Rejection Ratio

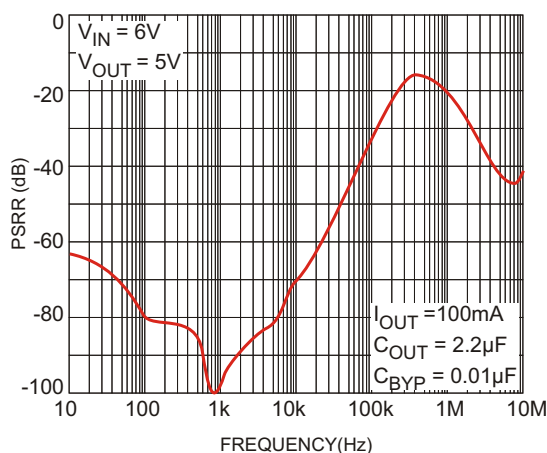

Figure 7. Power Supply Rejection Ratio

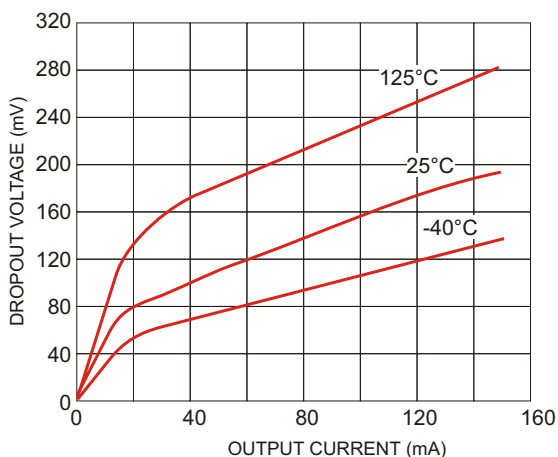

Figure 8. Dropout Voltage vs. Output Current

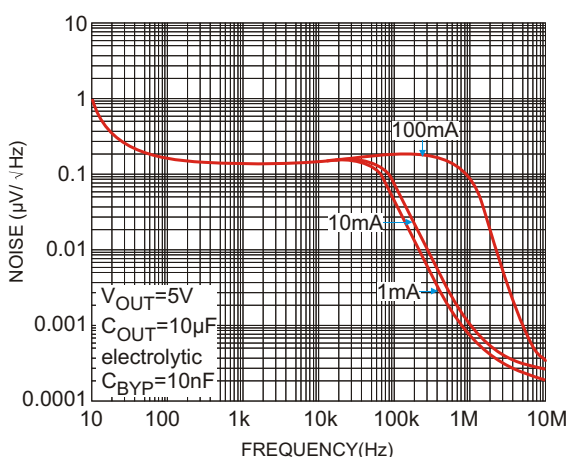
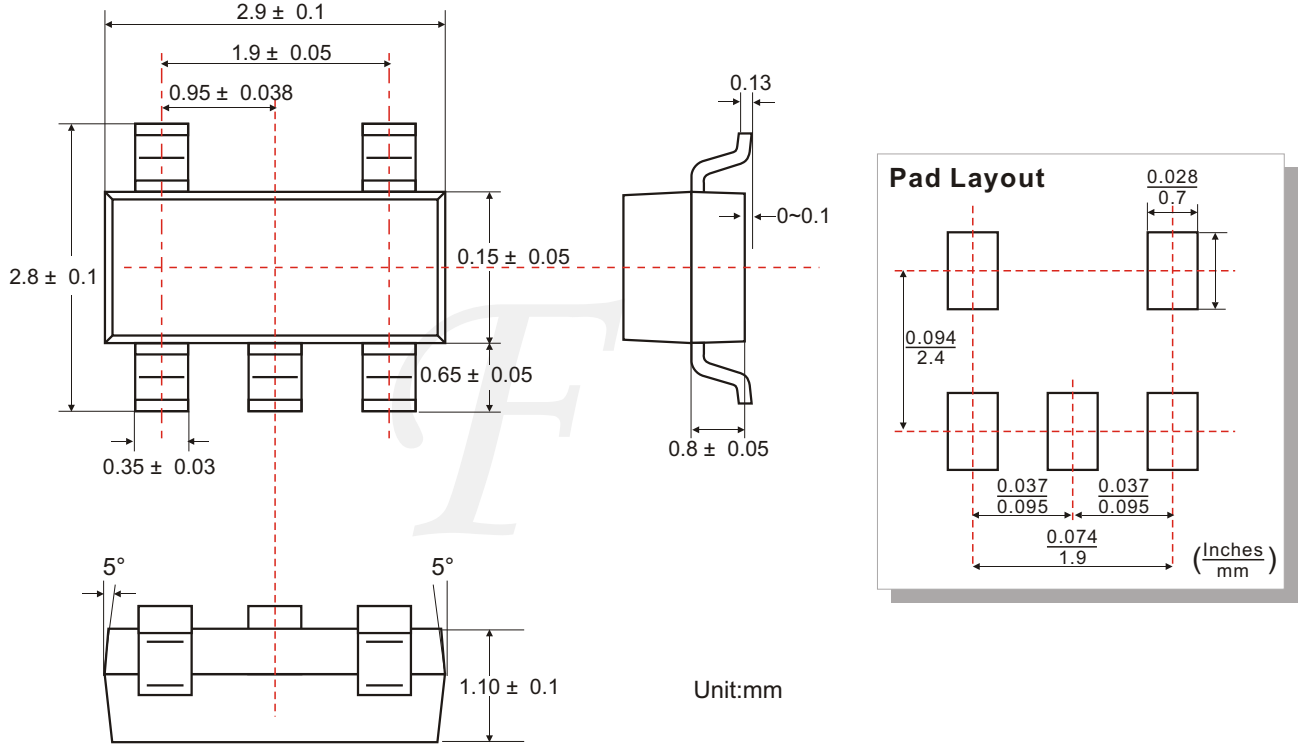

Figure 9. Noise Performance

◆ SOT-25(SOT-23-5) PACKAGE OUTLINE DIMENSIONS



◆ ORDERING NUMBER

