

1510 nm Transmitter Module for Supervisory Channel Applications

Key Features

- Provides 1510 nm supervisory channel laser source for WDM applications according to ITU-T draft G.691
- Average power control
- Small size (40x70x9 mm)
- CMOS alarm output
- Thermoelectric cooler included
- P-ECL data inputs
- Tone modulation input
- Single 5.0 V supply

Applications

- 1510 nm supervisory channel applications in WDM systems



Description

The transmitter module is intended for use at SDH and SONET bit rates. The device meets the intention of the ITU-T (G.691) recommendations.

The single silicon IC is used as a laser driver, modulator and automatic power control. To ensure a proper laser operation over the wide temperature range and life of operation, the average optical output power is controlled. The laser bias is externally accessible for monitoring of the performance. A power alarm is activated when the average optical power cannot be maintained within specification. A laser shut-down is also provided according to SDH/SONET requirements.

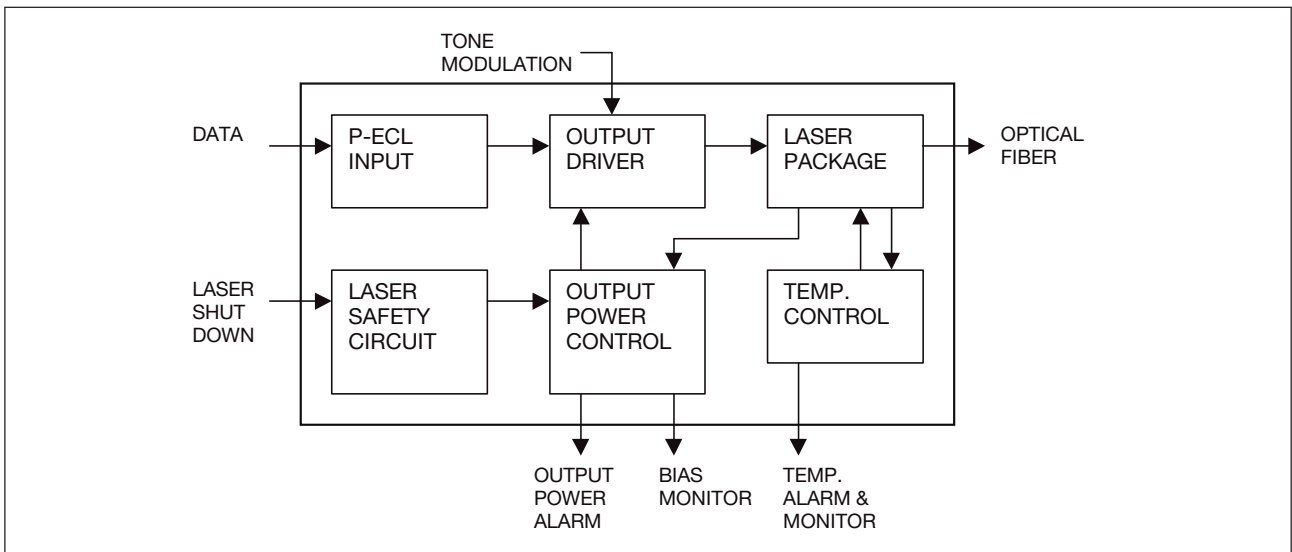

Figure 1. Block diagram

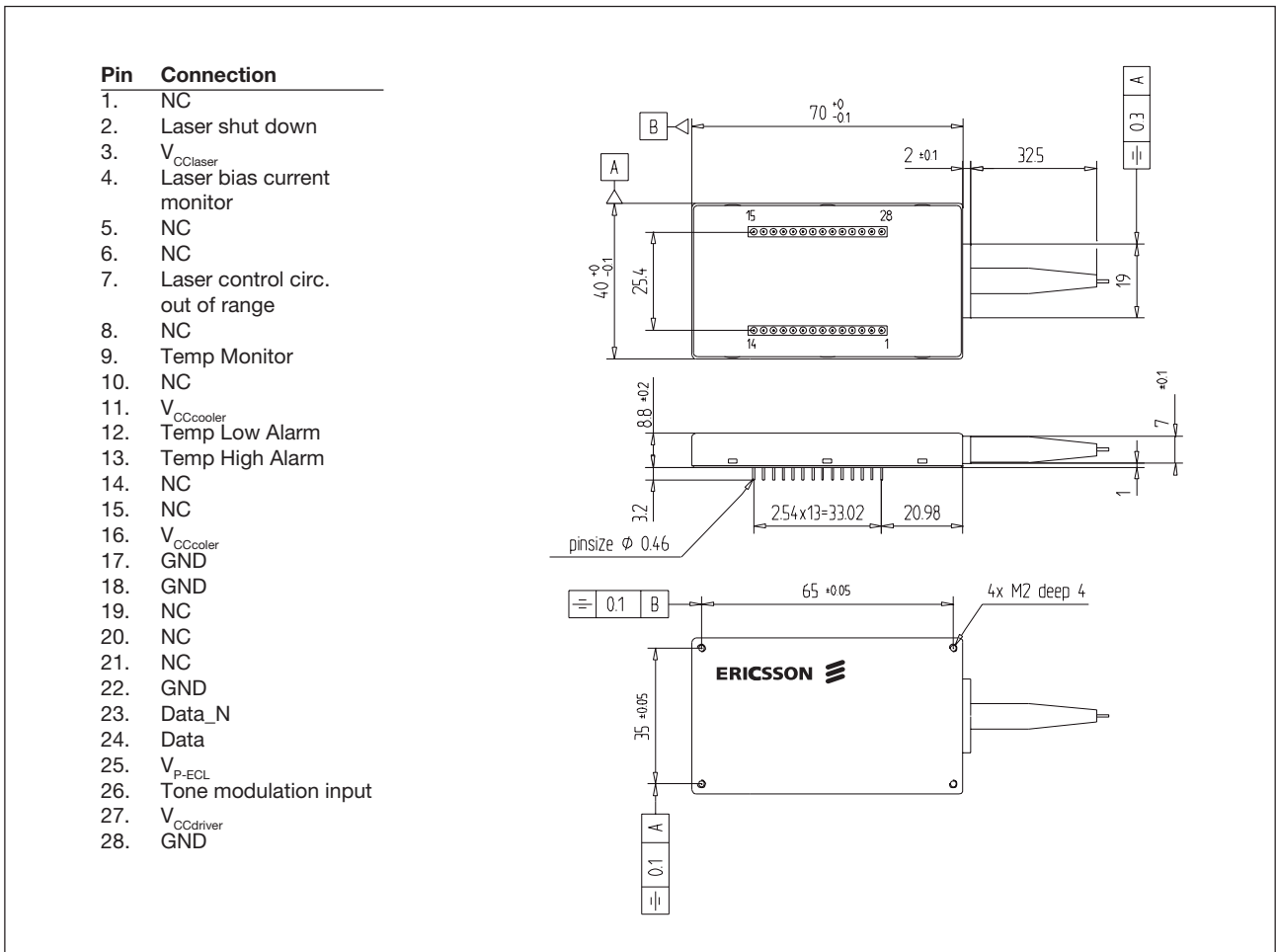

Figure 2. Mechanical outline and pin description

Optical Characteristics

Electrical and optical characteristics over recommended operating conditions, unless otherwise noted.

Parameter	Conditions	Symbol	Min	Typ	Max	Unit
Peak wavelength		λ_p	1502		1518	nm
Bit rate			2		155	Mb/s
Average output power	EOL	P	-3		+2	dBm
Side mode suppression ratio		SMSR	30			dB
Extinction ratio	EOL	EX	10			dB
Eye diagram				G.957		ITU-T

Electrical Characteristics

Parameter	Conditions	Symbol	Min	Typ	Max	Unit
Power supply			4.7		5.3	V
Operating current	without TEC				200	mA
Power supply TEC			3.0		5.3	V
Operating current TEC					650	mA
Input data				P-ECL		
Transmitter disable				CMOS		
Laser control circuitry out of range				CMOS		

Recommended Operating Conditions

Parameter	Symbol	Min	Typ	Max	Unit
Operating case temperature	T_{Case}	0		70	°C

Absolute Maximum Ratings

Parameter	Symbol	Min	Max	Unit
Storage temperature	T_{Sto}	-40	85	°C
Supply voltage		-0.5	6.0	V

CAUTION: Stresses outside those listed in "Absolute Maximum Ratings" may cause permanent damage to the device. This is a stress only rating and operation of the device at these or any other conditions above those indicated in the operational sections of this specification is not implied.

Handling Precautions

This device may be damaged as a result of electrostatic discharge (ESD). Take proper precautions during both handling and testing. This typically includes grounded wrist wraps, workbenches and floor mats in ESD controlled areas. Semiconductor devices may be damaged by current surges, use appropriate transient protection.

Quality Assurance

Ericsson Microelectronics commitment to quality has been proven through a decade of semiconductor device production and has been confirmed to ISO 9001. Opto product qualification is made according to the intention of applicable Telcordia standards.

Connector Options

FC/PC

SC

(Other connectors available on request)

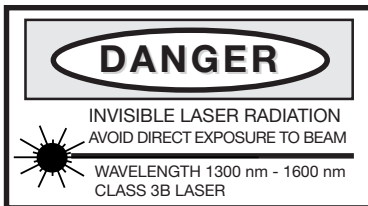

Information given in this data sheet is believed to be accurate and reliable. However no responsibility is assumed for the consequences of its use nor for any infringement of patents or other rights of third parties which may result from its use. No license is granted by implication or otherwise under any patent or patent rights of Ericsson Microelectronics. These products are sold only according to Ericsson Microelectronics' general conditions of sale, unless otherwise confirmed in writing.

Product specifications subject to change without notice.

Ericsson Microelectronics AB
SE-164 81 Kista, Sweden
Telephone: +46 8 757 50 00
www.ericsson.com/microelectronics

For local sales contacts, please refer to our website
or call: Int + 46 8 757 47 00, Fax: +46 8 757 47 76

1522-PGT 601 06 Rev. E
© Ericsson Microelectronics AB, November 2000