

液晶之友 电话: 020-33819057

Http://www.lcdfriends.com

**HANTRONIX**

## PRODUCT SPECIFICATION

# HDM3224-7

320x240 GRAPHICS  
LCD DISPLAY MODULE

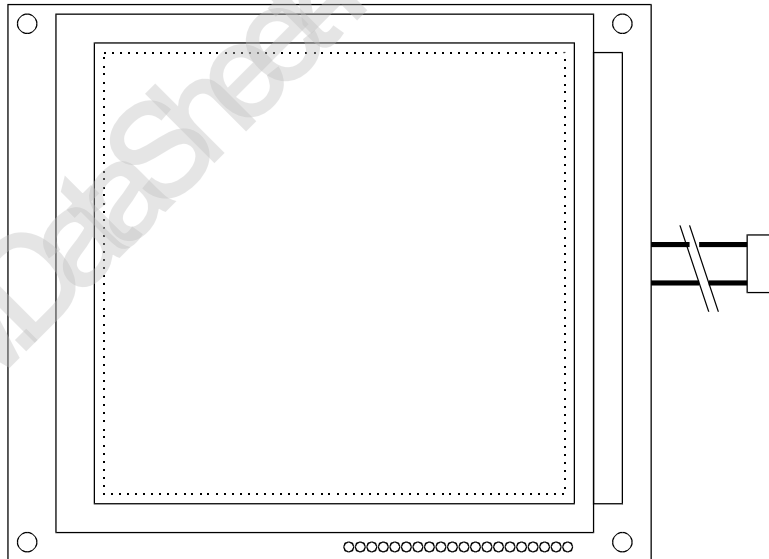

**HANTRONIX, INC.**  
10080 BUBB RD.  
CUPERTINO, CA 95014

Q.A.:  
JB

REV.:  
1.0

**HDM3224-7**

SHEET 1 OF 17

DATE:  
12/11/97

# MECHANICAL DATA

- (1) Product No.  
 (2) Module Size 166.0 (W)mm x 134.0(H)mm x MAX 15:1 (D)mm (CCFL B/L)  
 (3) Dot Size 0.32 (W)mm x 0.39 (H)mm  
 (4) Dot Pitch 0.36 (W)mm x 0.43 (H)mm  
 (5) Number of Dots 320 (W) x 240 (H)Dots  
 (6) Duty 1/240  
 (7) LCD Display Mode STN:  Gray Mode  Yellow Mode  Blue Mode  
 FSTN:  Black and White(Normal White/Positive Image)  
 Black and White(Normal Black/Negative Image)  
 Rear Polarizer:  Reflective  Transflective  Transmissive  
 (8) Viewing Direction  6 O'clock  12 O'clock  \_\_\_\_O'clock  
 (9) Backlight  W/O  CCFL B/L  
 (10) Weight CCFL B/L 350 g(approx.)  
 (11) Controller Without  
 (12) DC/DC Converter Whitout

Note :

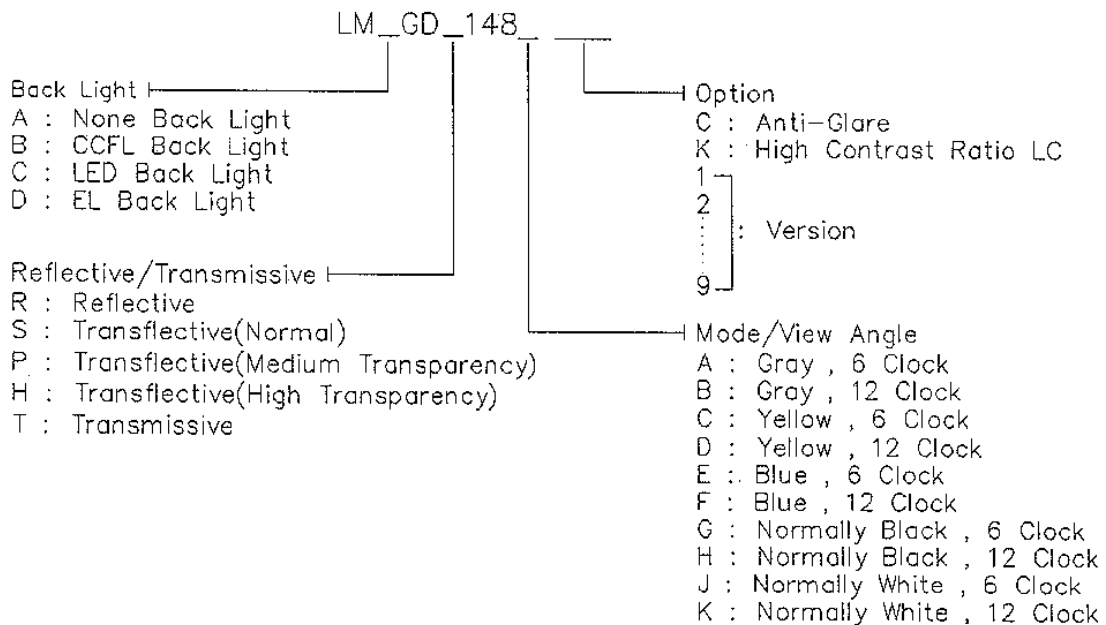

<b>HANTRONIX, INC.</b> 10080 BUBB RD. CUPERTINO, CA 95014	Q.A.:	REV.:	<b>HDM3224-7</b>	SHEET 2 OF 17
	JB	1.0		DATE: 10/12/98

# ABSOLUTE MAXIMUM RATINGS

## (1) ELECTRICAL ABSOLUTE RATINGS

VSS=0V

ITEM	SYMBOL	MIN	MAX	UNIT	COMMENT
Power Supply for Logic	VDD-VSS	-0.3	7.0	V	
Power Supply for LC Drive	VDD-VLC	-0.3	30.0	V	
Input Voltage	VI	0	VDD	V	
Static Electricity	-	-	-	-	Note 1

Note 1 LCM should be grounded during handling LCM.

## (2) ENVIRONMENTAL ABSOLUTE MAXIMUM RATINGS

ITEM	NORMAL TEMP.				WIDE TEMP.			
	OPERATING		STORAGE		OPERATING		STORAGE	
	MIN.	MAX.	MIN.	MAX.	MIN.	MAX.	MIN.	MAX.
Ambient Temperature	0	50	-20	70	-20	70	-30	80
Humidity (Without Condensation)	Note 1,3		Note 2,3		Note 3,4		Note 3,5	

Note 1  $T_a \leq 50^\circ\text{C}$  : 85%RH max.

$T_a > 50^\circ\text{C}$  : Absolute humidity must be lower

than the humidity of 85%RH at  $50^\circ\text{C}$

Note 2  $T_a$  at  $-20^\circ\text{C}$  will be < 48hrs, at  $70^\circ\text{C}$  will be < 120hrs

Note 3 Background color changes slightly depending on ambient temperature.

This phenomenon is reversible.

Note 4  $T_a \leq 70^\circ\text{C}$  : 75%RH max

$T_a > 70^\circ\text{C}$  : Absolute humidity must be lower

than the humidity of 75%RH at  $70^\circ\text{C}$

Note 5  $T_a$  at  $-30^\circ\text{C}$  will be < 48hrs, at  $80^\circ\text{C}$  will be < 120hrs

<b>HANTRONIX, INC.</b> 10080 BUBB RD. CUPERTINO, CA 95014	Q.A.:	REV.:	<b>HDM3224-7</b>	SHEET 3 OF 17
	JB	1.0		DATE:

# ELECTRICAL CHARACTERISTICS

ITEM	SYMBOL	CONDITION	MIN.	TYP.	MAX.	UNIT	
Logic Circuit Power Supply	VDD-VSS	-	4.75	5.0	5.25	V	
Recommended LCD Driving Voltage	VDD-V0	Duty=1/240 VDD=5.0V	-20°C	-	24.5	-	V
			0°C	-	23.1	-	
			25°C	-	22.2	-	
			50°C	-	21.4	-	
			70°C	-	20.3	-	
Input Voltage	V <sub>IH</sub>	H level	0.8VDD	-	VDD	V	
	V <sub>IL</sub>	L level	0	-	0.2VDD	V	
Supply Current for Logic	I <sub>DD</sub>	VDD = 5.0V V0 = -18.7V	1.9	4.3	-	mA	
Supply Current for LCD	I <sub>O</sub>	PATTERN : <div style="display: flex; flex-wrap: wrap; gap: 5px;"> <span>□</span><span>■</span><span>□</span><span>■</span><span>□</span> </div> <div style="display: flex; flex-wrap: wrap; gap: 5px;"> <span>■</span><span>□</span><span>■</span><span>□</span><span>■</span> </div> <div style="display: flex; flex-wrap: wrap; gap: 5px;"> <span>□</span><span>■</span><span>□</span><span>■</span><span>□</span> </div>	1.7	4.1	-	mA	
CCFL B/L	Open Voltage	V <sub>OPEN</sub>	-	-	1500	Vrms	
	Lamp Voltage	V <sub>L</sub>	-	260	-	Vrms	
	Brightness	B	-	350	-	cd/m <sup>2</sup>	
	Color Degree	X	Lamp Current = 5 mArms Frequency = 30 KHz	-	0.331	-	-
Y		-		0.377	-		

<b>HANTRONIX, INC.</b> 10080 BUBB RD. CUPERTINO, CA 95014	Q.A.:	REV.:	<b>HDM3224-7</b>	SHEET 4 OF 17
	JB	1.0		DATE: 10/12/98

# OPTICAL CHARACTERISTICS

AT Vop

ITEM MODE		Cr(Contrast Ratio)		$\theta$ (Viewing Angle)		$\phi$ (Viewing Angle)	
		25 $\text{c}$		25 $\text{c}$		25 $\text{c}$	
		MIN.	TYP.	MIN.	TYP.	MIN.	TYP.
R	A,B	-	-	-	-	-	-
	C,D	-	-	-	-	-	-
	J	-	-	-	-	-	-
S	J	-	4.1	-	30	-	50
note		NOTE6		NOTE5			

AT  $\phi=0^\circ$   $\theta=0^\circ$

ITEM	SYMBOL	CONDITION	MIN.	TYP.	MAX.	UNIT	NOTE
Response Time (rise)	Tr	-20 $\text{c}$	—	3460	—	ms	NOTE 2
		0 $\text{c}$	—	725	1200		
		25 $\text{c}$	—	245	400		
		50 $\text{c}$	—	140	200		
		70 $\text{c}$	—	80	150		
Response Time (fall)	Tf	-20 $\text{c}$	—	3000	—	ms	NOTE 2
		0 $\text{c}$	—	1290	2100		
		25 $\text{c}$	—	430	700		
		50 $\text{c}$	—	200	400		
		70 $\text{c}$	—	130	250		

note:

R: REFLECTIVE  
 S: TRANSFLECTIVE  
 A,B: GRAY  
 C,D: YELLOW  
 J: NORMALLY WHITE

<b>HANTRONIX, INC.</b> 10080 BUBB RD. CUPERTINO, CA 95014	Q.A.:	REV.:	<b>HDM3224-7</b>	SHEET 5 OF 17
	JB	1.0		DATE:

# BLOCK DIAGRAM

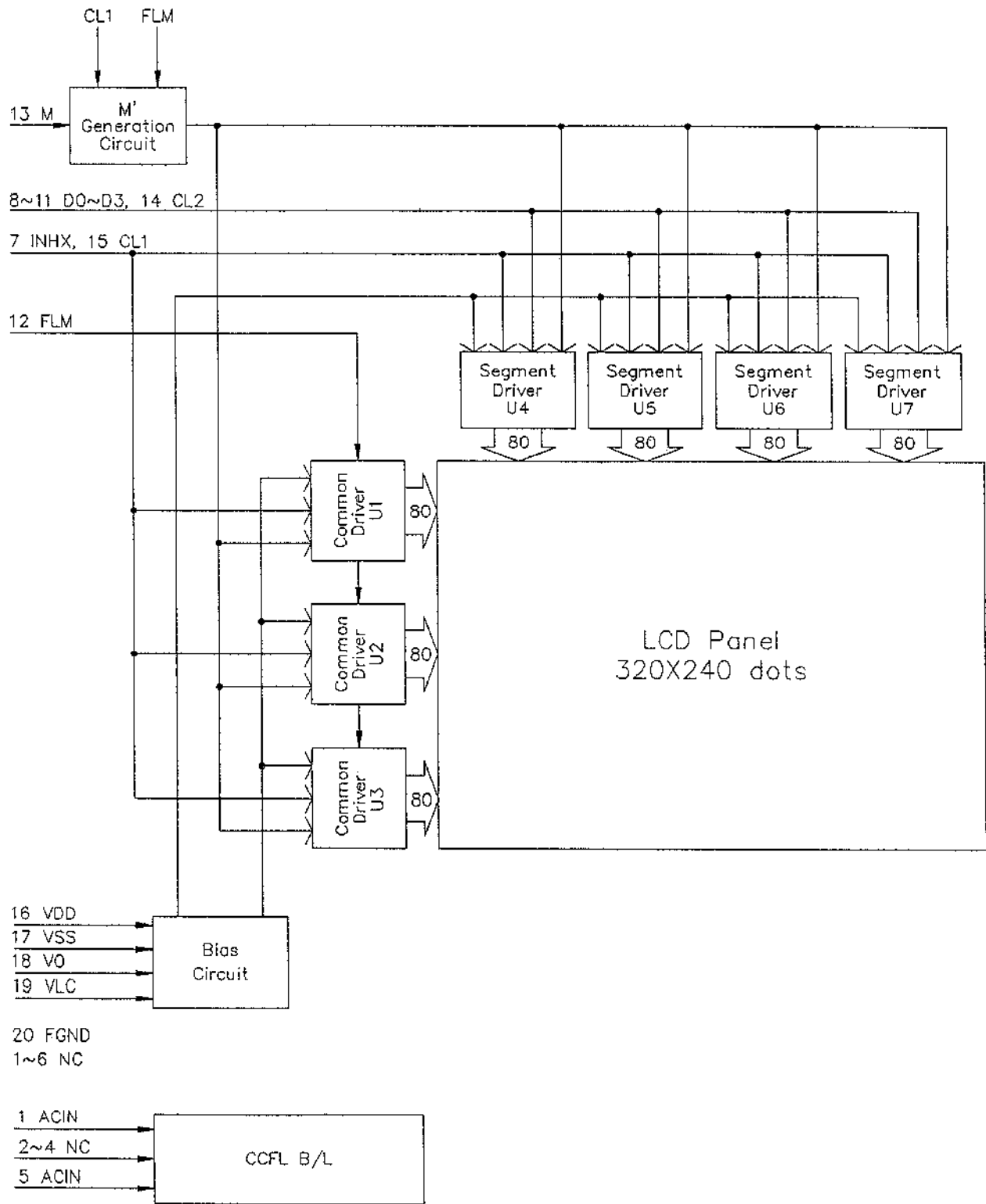

<b>HANTRONIX, INC.</b> 10080 BUBB RD. CUPERTINO, CA 95014	Q.A.:	REV.:	<b>HDM3224-7</b>	SHEET 6 OF 17
	JB	1.0		DATE: 10/12/98

# INTERNAL PIN CONNECTION

## LCD

Pin No.	Symbol	Function
1	NC	Not Connected
2	NC	Not Connected
3	NC	Not Connected
4	NC	Not Connected
5	NC	Not Connected
6	NC	Not Connected
7	INHx	Display ON/OFF Control Signal : 1=ON 0=OFF
8	D0	Display Data Input
9	D1	Display Data Input
10	D2	Display Data Input
11	D3	Display Data Input
12	FLM	First Line Marker
13	M	Liquid Crystal AC Drive Control Signal
14	CL2	Data Shift Clock
15	CL1	Data Latch Clock
16	VDD	Logic Power Supply (+)
17	VSS	GND (0V)
18	V0	Liquid Crystal Contrast Adjustment
19	VLC	Liquid Crystal Drive Voltage
20	FGND	Frame Ground

## CCFL B/L

Pin No.	Symbol	Function
1	AC IN	AC Power Input
2	NC	Not Connected
3	NC	Not Connected
4	NC	Not Connected
5	AC IN	AC Power Input

**HANTRONIX, INC.**  
10080 BUBB RD.  
CUPERTINO, CA 95014

Q.A.:  
JB

REV.:  
1.0

**HDM3224-7**

SHEET 7 OF 17

DATE:  
10/12/98

# POWER SUPPLY

LCM

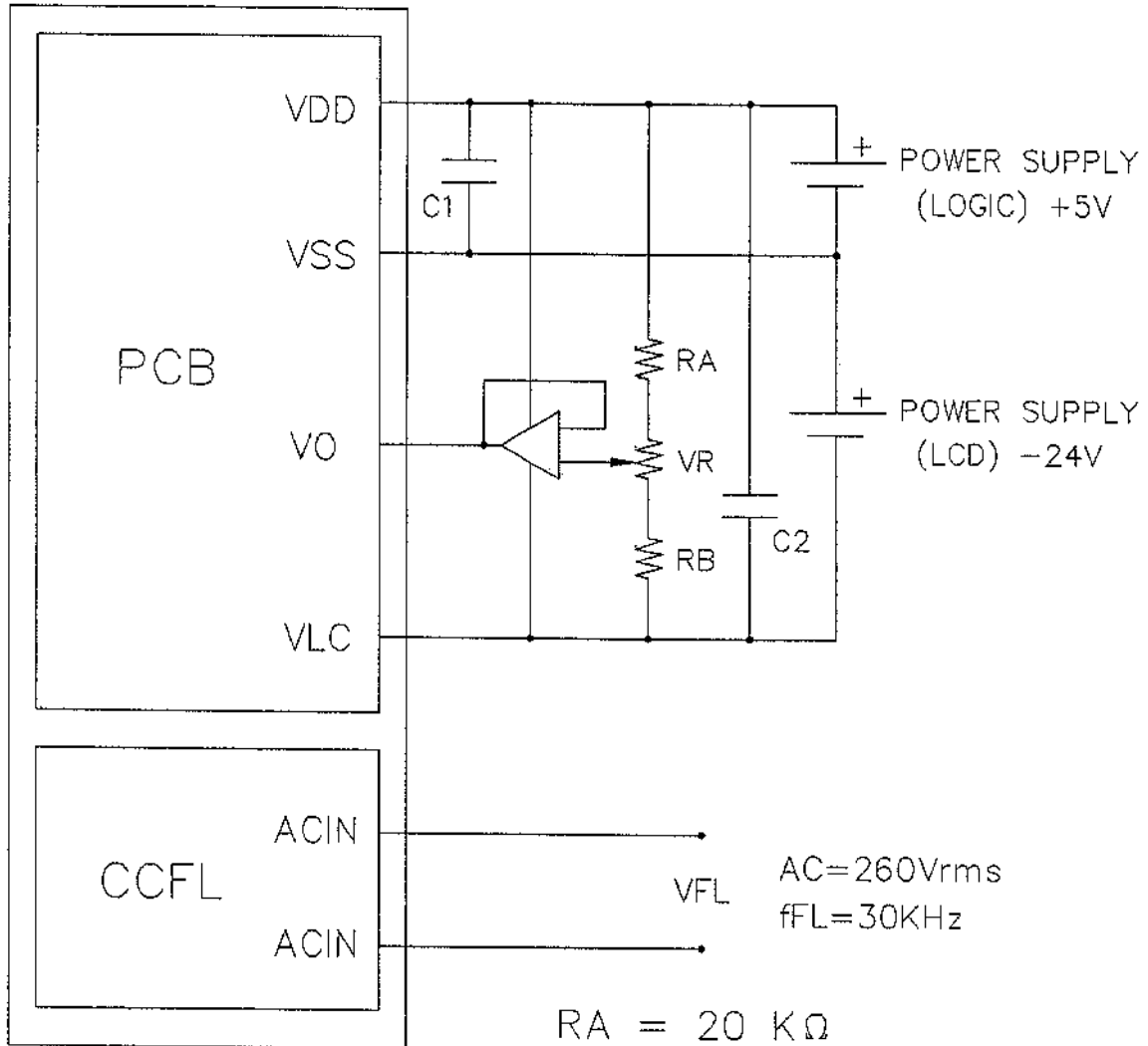

$$RA = 20 \text{ K}\Omega$$

$$RB = 0.1 \text{ K}\Omega$$

$$VR = 10 \text{ K}\Omega(\text{VARIABLE})$$

$$C1, C2 = 10 \text{ }\mu\text{F}$$

**HANTRONIX, INC.**  
10080 BUBB RD.  
CUPERTINO, CA 95014

Q.A.:  
JB

REV.:  
1.0

**HDM3224-7**

SHEET 8 OF 17

DATE:  
10/12/98



# TIMING CHARACTERISTICS

## 8-1 COMMON DRIVER OPERATION TIMING

VDD=2.7~4.5V

ITEM	SYMBOL	MIN.	TYP.	MAX.	UNIT
CLOCK CYCLE TIME	$t_{cyc}$	10	-	-	$\mu s$
CLOCK HIGH LEVEL WIDTH	$t_{cwh}$	80	-	-	ns
CLOCK LOW LEVEL WIDTH	$t_{cwl}$	1.0	-	-	$\mu s$
CLOCK RISE/FALL TIME	$t_r, t_f$	-	-	30	ns
DATA SETUP TIME	$t_{ds}$	100	-	-	ns
DATA HOLD TIME	$t_{dh}$	100	-	-	ns
DATA OUTPUT DELAY TIME	$t_{dd}$	-	-	7.0	$\mu s$

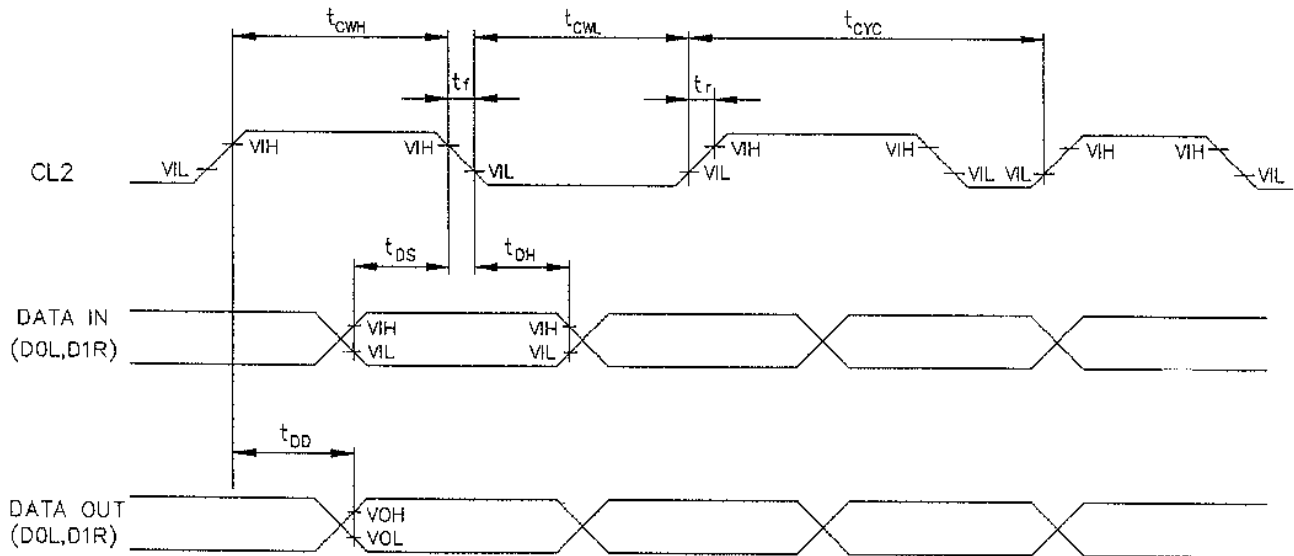

**HANTRONIX, INC.**  
10080 BUBB RD.  
CUPERTINO, CA 95014

Q.A.:  
JB

REV.:  
1.0

**HDM3224-7**

SHEET 9 OF 17

DATE:  
10/12/98

# SEGMENT DRIVER OPERATION TIMING

VDD=2.7~4.5V

ITEM	SYMBOL	MIN.	TYP.	MAX.	UNIT
CLOCK FREQUENCY	$f_{cl2}$	-	-	6.5	MHZ
CLOCK CYCLE TIME	$t_{cyc}$	152	-	-	ns
CLOCK PULSE WIDTH	$t_{cwh}, t_{cwl}$	65	-	-	ns
CLOCK RISE, FALL TIME	$t_r, t_f$	-	-	1	ns
CLOCK SETUP TIME	$t_{scl}$	80	-	-	ns
CLOCK HOLD TIME	$t_{hcl}$	120	-	-	ns
DATA SETUP TIME	$t_{ds}$	50	-	-	ns
DATA HOLD TIME	$t_{dh}$	50	-	-	ns
ENABLE SETUP TIME	$t_{esu}$	30	-	-	ns
CARRY OUTPUT DELAY TIME	$t_{car}$	-	-	100	ns
M PHASE DIFFERENCE	$t_{cm}$	-	-	300	ns
CL1 CYCLE TIME	$t_{cl1}$	$t_{cyc} \times 50$	-	-	ns

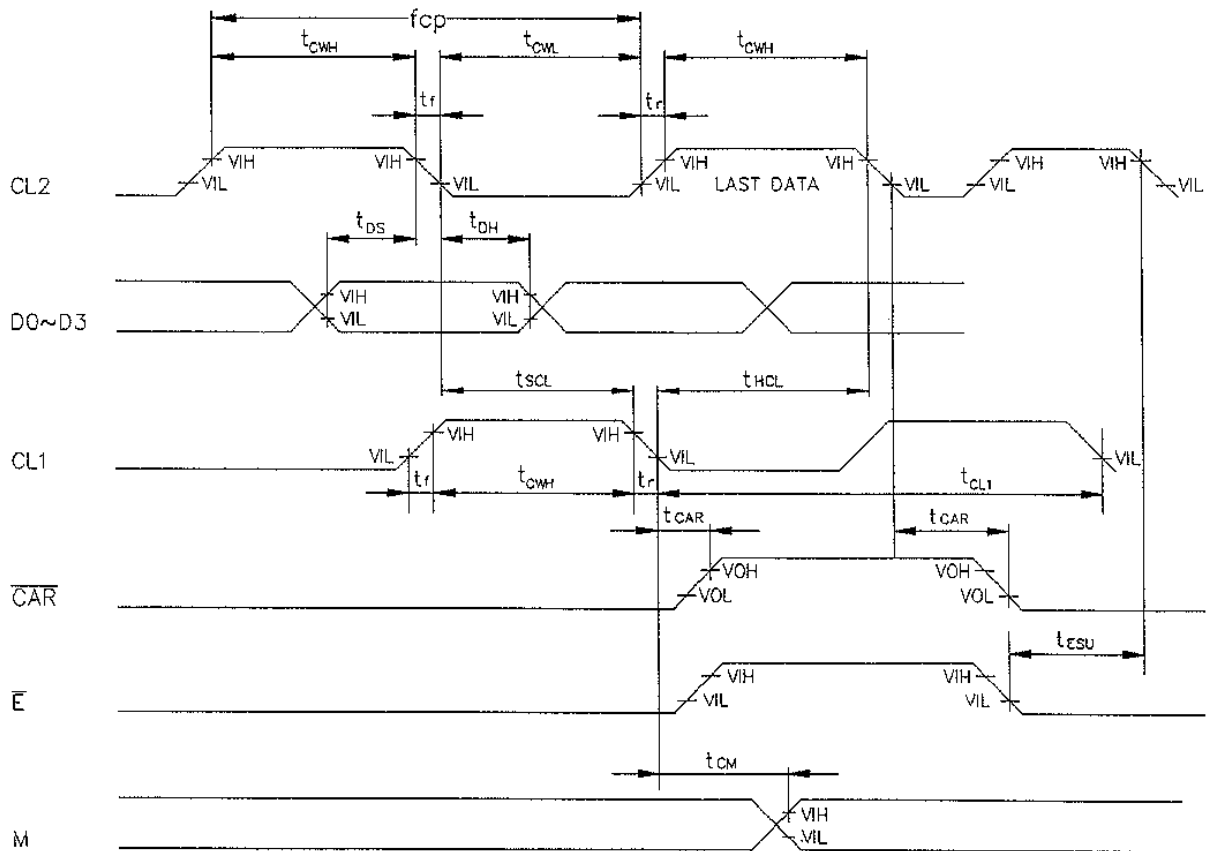

HANTRONIX, INC.  
10080 BUBB RD.  
CUPERTINO, CA 95014

Q.A.:  
JB

REV.:  
1.0

HDM3224-7

SHEET 10 OF 17

DATE:  
10/12/98

# TIMING CHART OF INPUT SIGNALS

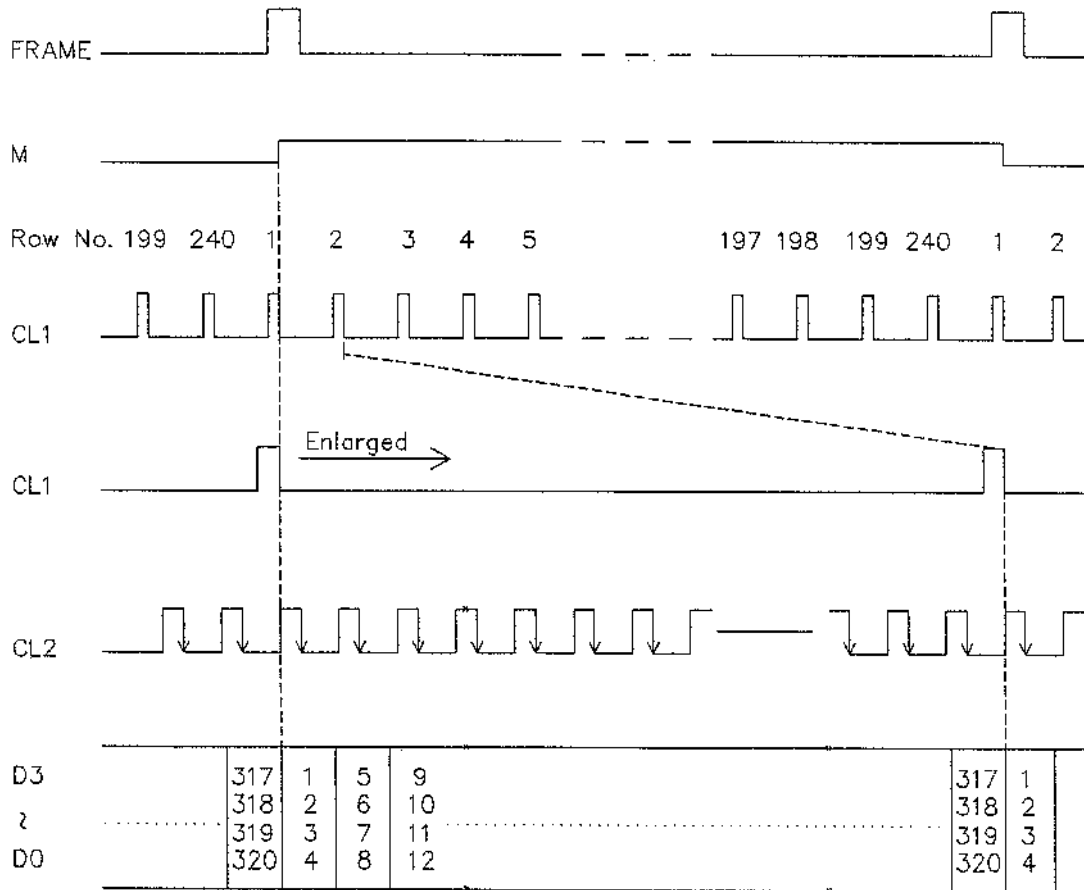

## RELATION OF INPUT DATA AND OUTPUT LATCH DATA

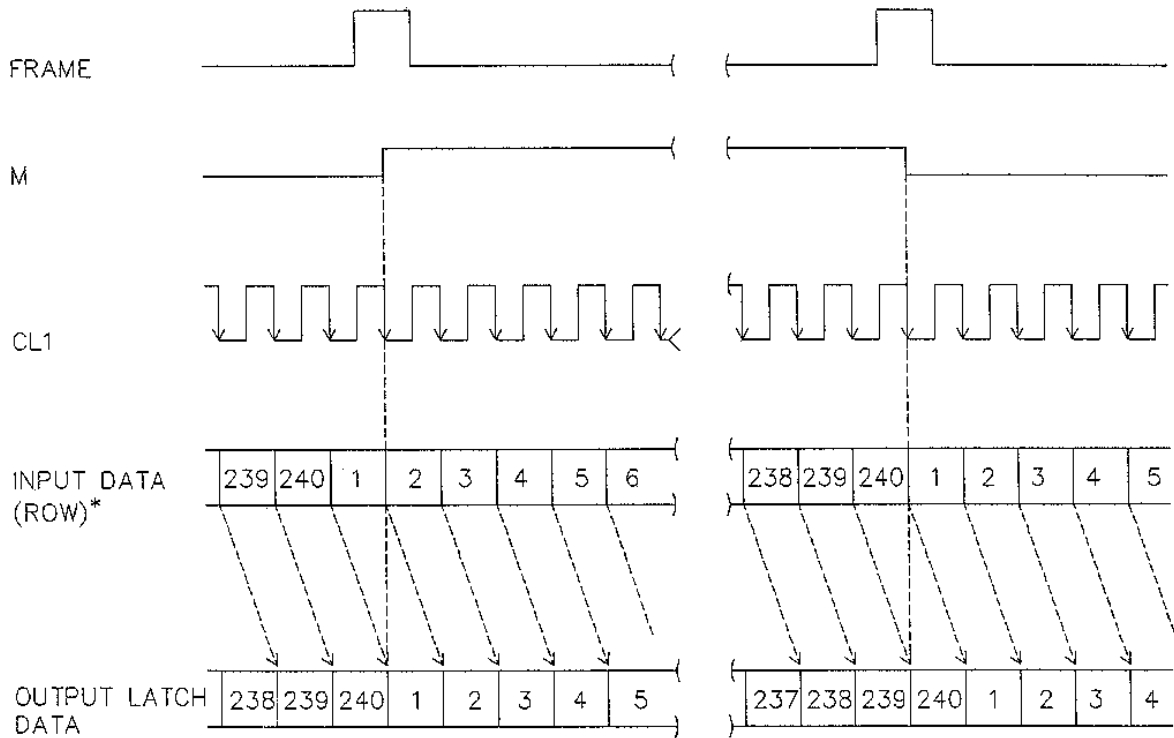

\* ONE ROW DATA INCLUDE 80 COLUMN DATA,  
ONE COLUMN DATA INCLUDE 4 BIT DATA

**HANTRONIX, INC.**  
10080 BUBB RD.  
CUPERTINO, CA 95014

Q.A.:  
JB

REV.:  
1.0

**HDM3224-7**

SHEET 12 OF 17

DATE:  
10/12/98

# DISPLAY PATTERN

#001	D3	D2	D1	D0	D3					D0	D3	D2	D1	D0
#002	D3	D2	D1	D0	D3					D0	D3	D2	D1	D0
<p>Data Input: Terminal : Dots (Row) on Display</p> <p>-----</p> <p>D3 : dot 1, dot 5 ..... dot 313, dot 317  D2 : dot 2, dot 6 ..... dot 314, dot 318  D1 : dot 3, dot 7 ..... dot 315, dot 319  D0 : dot 4, dot 8 ..... dot 316, dot 320</p>														
#239	D3	D2	D1	D0	D3					D0	D3	D2	D1	D0
#240	D3	D2	D1	D0	D3					D0	D3	D2	D1	D0
	#1	#2	#3	#4						#316	#317	#318	#319	#320

240 DOTS

320 DOTS

(NOTE 1)

Definition of Operation Voltage(Vop)

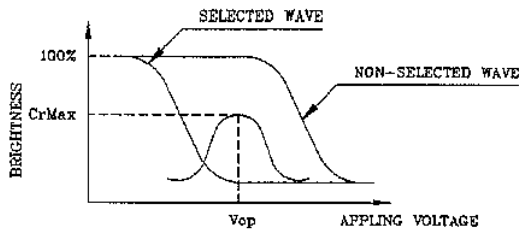

(positive type)

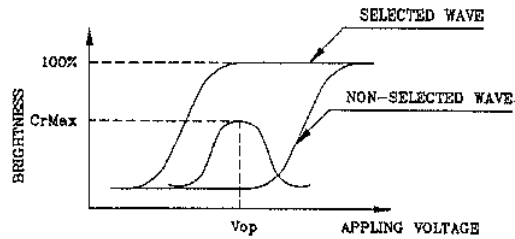

(negative type)

\*Conditions

Viewing Angle : 0  
 Frame Frequency : 70Hz  
 Appling Waveform : 1/N duty 1/a bias

(NOTE 2)

Definition of Response Time(Tr,Tf)

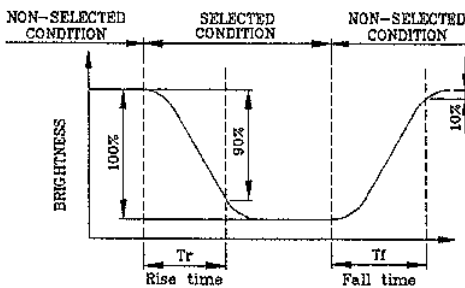

(positive type)

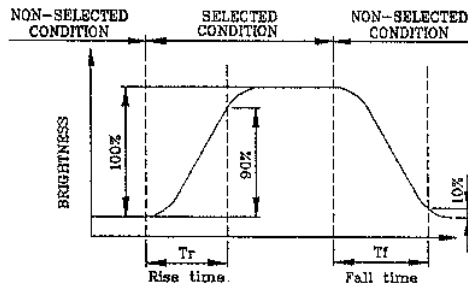

(negative type)

\*Conditions

Operating Voltage : Vop  
 Viewing Angle (θ,θ) : (0,0)  
 Frame Frequency : 70Hz  
 Appling Waveform : 1/N duty 1/a bias

(NOTE 3)

Description of Measuring Equipment and Driving Waveforms

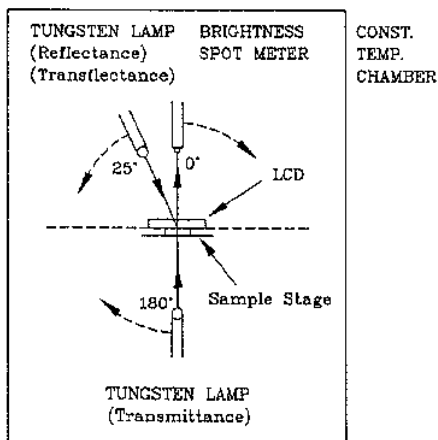

Multiplex Driving ( 1/N duty 1/a bias )

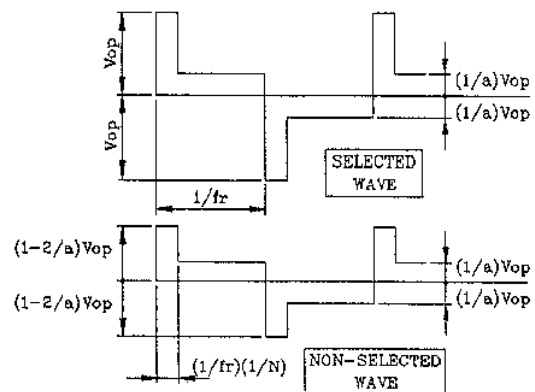

<b>HANTRONIX, INC.</b> 10080 BUBB RD. CUPERTINO, CA 95014	Q.A.:	REV.:	<b>HDM3224-7</b>	SHEET 14 OF 17
	JB	1.0		DATE:

(NOTE 4)

Definition of Viewing Direction

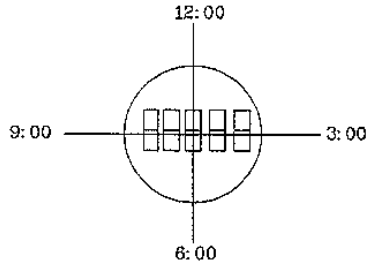

(NOTE 5)

Definition of Viewing Angle

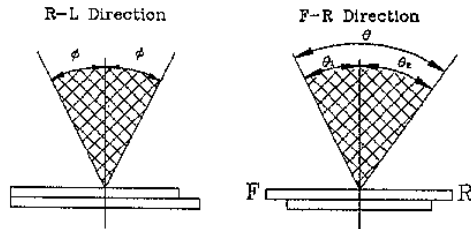

\*Conditions

- Operating Voltage :  $V_{op}$
- Frame Frequency : 70Hz
- Applying Waveform : 1/N duty 1/a bias
- Contrast Ratio : larger than 2

(NOTE 6)

Definition of Contrast Ratio (Cr)

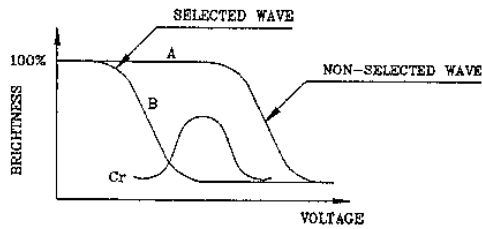

(positive type)

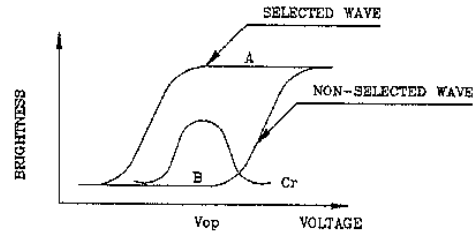

(negative type)

Contrast Ratio :  $Cr=A/B$

\*Conditions

- Viewing Angle : 0
- Frame Frequency : 70Hz
- Applying Waveform : 1/N duty 1/a bias

**HANTRONIX, INC.**  
 10080 BUBB RD.  
 CUPERTINO, CA 95014

Q.A.:  
 JB

REV.:  
 1.0

**HDM3224-7**

SHEET 15 OF 17

DATE:  
 10/12/98

(2) NOTE:

• SAFETY

- 1.If the LCD panel breaks, be careful not to get the liquid crystal to touch your skin.
- 2.If the liquid crystal touches your skin or clothes, please wash it off immediately by using soap and water.

• HANDLING

- 1.Avoid static electricity which can damage the CMOS LSI.
- 2.Do not remove the panel or frame from the module.
- 3.The polarizing plate of the display is very fragile. So, please handle it very carefully.
- 4.Do not wipe the polarizing plate with a dry cloth, as it may easily scratch the surface of plate.
- 5.Do not use ketonics solvent & Aromatic solvent, use with a soft cloth soaked with a cleaning naphtha solvent.

• STORAGE

- 1.Store the panel or module in a dark place where the temperature is  $25^{\circ}\text{C}\pm 5^{\circ}\text{C}$  and the humidity is below 65% RH.
- 2.Do not place the module near organics solvents or corrosive gases.
- 3.Do not crush, shake, or jolt the module.

• TERMS OF WARRANT

- 1.Acceptance inspection period  
The period is within one month after the arrival of contracted commodity at the buyer's factory site.
- 2.Applicable warrant period  
The period is within twelve months since the date of shipping out under normal using and storage conditions.

• THE OPERATING LIFE TIME OF BACK LIGHT

- LED : 50,000HR  
EL : 5,000HR  
CCFT : 10,000HR

<b>HANTRONIX, INC.</b> 10080 BUBB RD. CUPERTINO, CA 95014	Q.A.:	REV.:	<b>HDM3224-7</b>	SHEET 16 OF 17
	JB	1.0		DATE: 10/12/98



CN1 PIN CONNECTION

NO.	Symbol	NO.	Symbol
1	NC	11	D3
2	NC	12	FLM
3	NC	13	M
4	NC	14	CL2
5	NC	15	CL1
6	NC	16	VDD
7	INH	17	VSS
8	D0	18	VO
9	D1	19	VLC
10	D2	20	FGND

CN2 CCFL PIN CONNECTION

NO.	Symbol
1	AC IN
2	NC
3	NC
4	NC
5	AC IN

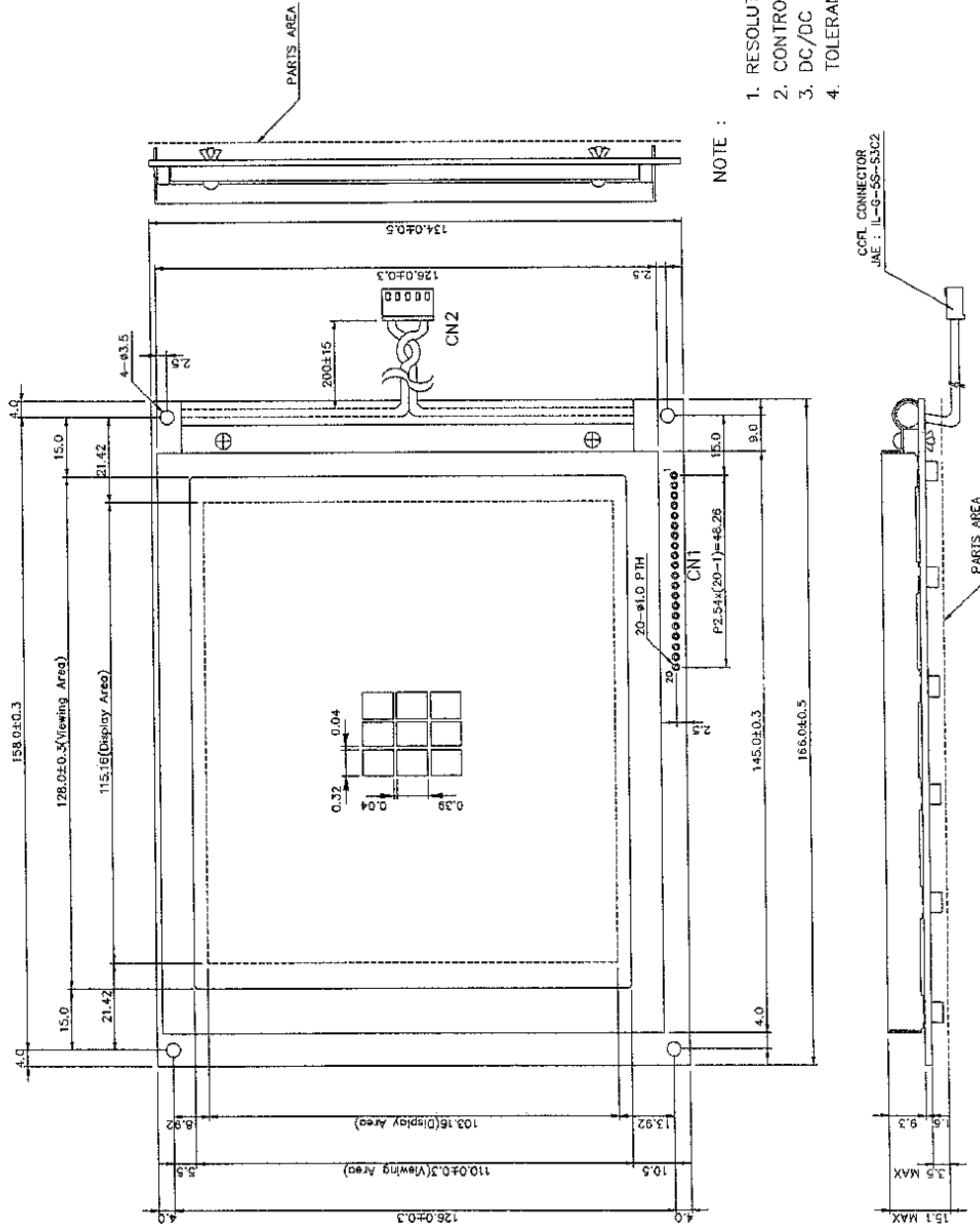

NOTE :

1. RESOLUTIONS : 320 x 240 DOTS
2. CONTROLLER : WITHOUT
3. DC/DC CONVERTER : WITHOUT
4. TOLERANCE NO SPECIFIED : ±0.5 mm

**HANTRONIX, INC.**  
10080 BUBB RD.  
CUPERTINO, CA 95014

Q.A.:  
JB

REV.:  
1.0

**HDM3224-7**

SHEET 17 OF 17

DATE: 10/12/98