

- Available Rear Release/Rear Removable Front Release/Front Removable
- Low Insertion force contacts.
- Both environmental and non-environmental versions.
- Polarizing post that are removable from the mating face.
- Field replaceable inserts.
- Up to 150 Size #22 contacts per connector.
- Crimp, coax, twinax, printed circuit and wire wrappable post style contacts.
- Uses standard ARINC 600, crimp, insertion/extraction tooling.



SGA connectors utilize all the Signal cavity inserts and contacts from the ARINC 600 connector series. It was designed to be used where there are space constraints in which a standard ARINC 600 connector can not be used. ITT Cannon's SGA connector fills the need for a 150 maximum contact connector with a smaller shell design than Shell Size 2 of ARINC 600, and has more contacts available than single gang DPX with 106 Size 22 contacts.

Materials and Finishes

		SGA*D	SGA*E	SGA*F	Specifications
Shell	Material	Aluminum alloy	Aluminum alloy	Aluminum alloy	QQ-A-591/A380
	Finish	Clear chromate over cadmium	Clear chromate over cadmium	Clear chromate over cadmium	QQ-P-416
Insulator	Material	Thermoplastic	Thermoplastic	Thermoset	N/A
	Material	Copper alloy	Copper alloy	Copper alloy	QQ-C-533
Contacts	Finish	Gold	Gold	Gold	MIL-G-45204
	Termination	Crimp	Crimp	P.C/Wrap Post	N/A
	Material	N/A	Silicone-based Elastomer	N/A	N/A
Grommets/Seals	Material	N/A	Silicone-based Elastomer	N/A	N/A
O-Ring	Material	N/A	Silicone-based Elastomer	N/A	N/A

How to Order (Refer to ARINC 600 [BKA] pages 13-16 for contact information.)

<p>CONNECTOR SERIES SGA (Single Gang ARINC 600)</p> <p>SHELL STYLE 3 - Plug (Rack Side) 4 - Receptacle (Box Side)</p> <p>CLASS C - Non-environmental with Grommet only, insulators are not potted into the connector shell. D - Non-environmental (rear release crimp contacts). E - Environmentally sealed (rear release crimp contacts). F - Non-environmental (front release, printed circuit or wire wrap posts). R - EMI/RFI Protected & Environmentally sealed, 0-ring omitted (plug only). (Reference ITTC Phoenix)</p> <p>CONTACT ARRANGEMENT (See ARINC 600 (BKA) contact arrangements, pages 9-10)</p> <p>CONTACT TYPE P - Pin Contacts S - Socket Contacts</p> <p>CONNECTOR MOUNTING MODIFIER Mounting modifiers 00, 03, 06, 14, 15, hole location is .705 basic from connector vertical centerline. 00 - .151 Dia. Mounting holes. 03 - .156 with #4-40 Self-Locking Clinch Nuts (ESNA #22NCFMA2-40) 4 per connector. 06 - .188 Dia. For #6-32 Clinch nuts (ESNA #12NCFMA2-62) 4 per connector. 14 - .137 Dia, Countersunk 82°x .230 Dia., Engaging face of mounting flange. 15 - .137 Dia, Countersunk 82 x .230 Dia., Engaging face of mounting flange. Supplied with slant shield grounding spring.</p>	<p>CONNECTOR SERIES _____</p> <p>SHELL STYLE _____</p> <p>CLASS _____</p> <p>CONTACT ARRANGEMENT _____</p> <p>CONTACT TYPE (PIN OR SOCKET) _____</p> <p>CONNECTOR MOUNTING MODIFIER _____</p> <p>POLARIZING POSITION _____</p> <p>CONTACT MODIFIER _____</p> <p>Mounting modifiers 05, 07, 08, 09, 10, 11, 12, 13, hole location is .650 basic from connector vertical centerline. 05 - .208 Dia. for Floating Eyelet 07 - .212/.204 Slot 4 places. 08 - .120 Dia. Countersunk 82°x .230 Dia., Engaging face of mounting flange. 09 - .120 Dia. Countersunk 82°x .230 Dia., Rear face of mounting flange. 10 - .120 Dia. Countersunk 100°x .230 Dia., Engaging face of mounting flange. 11 - .120 Dia. Countersunk 100°x .230 Dia., Rear face of mounting flange. 12 - .137 Dia. Countersunk 82°x .230 Dia., Engaging face of mounting flange. 13 - .137 Dia. Countersunk 82°x .230 Dia., Rear face of mounting flange.</p> <p>POLARIZING POSITION 01 - 36 Positions. (See Chart page 24) When the last two digits are omitted, the polarizing posts will not be assembled and position number is not stamped on the connector. This allows the user to position the post and stamp the appropriate number on the shell. If the last two digits are "00", polarizing posts are not supplied with the connector.</p>	<p>CONTACT MODIFIER Refer to page 13 for replacement contact part numbers and required termination tooling information. (Blank) - With standard Crimp type Rear release contacts. F0 - Contacts are not supplied with connector (FO not stamped on connector.) SA - Front release .025 Dia. x .150 Solder Post Size 22 Sockets SB - Front release .025 Dia. x .250 Solder Post Size 22 Sockets SC - Front release .025 Dia. x .375 Solder Post Size 22 Sockets SD - Front release .025 Dia. x .500 Solder Post Size 22 Sockets WA - Front release .025 Sq. x .250 (1 Wrap) WB - Front release .025 Sq. x .375 (2 Wrap) WC - Front release .025 Sq. x .500 (3 Wrap) WD - Front release .025 Sq. x .641 (3 Wrap)</p>
--	--	---

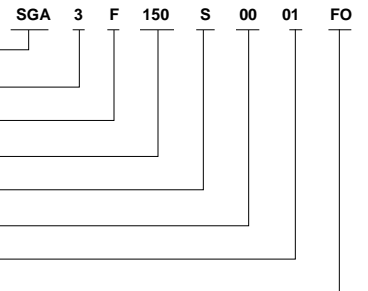

Plug Shell Dimensions

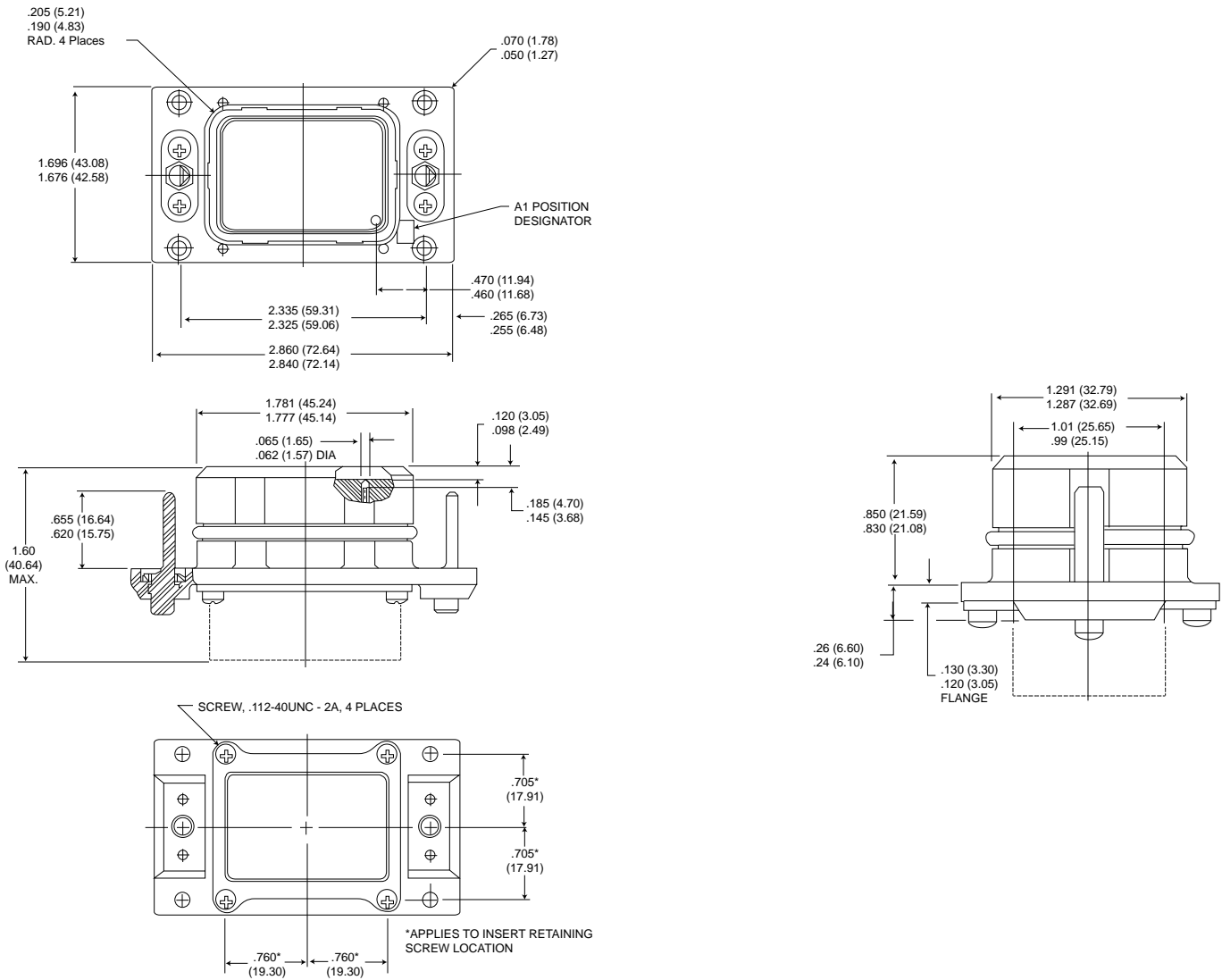

Recommended Panel Cutout

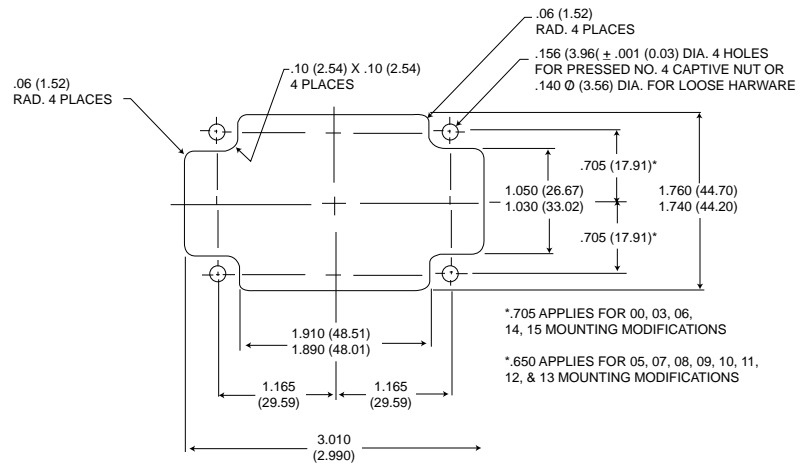

Receptacle Shell Dimensions

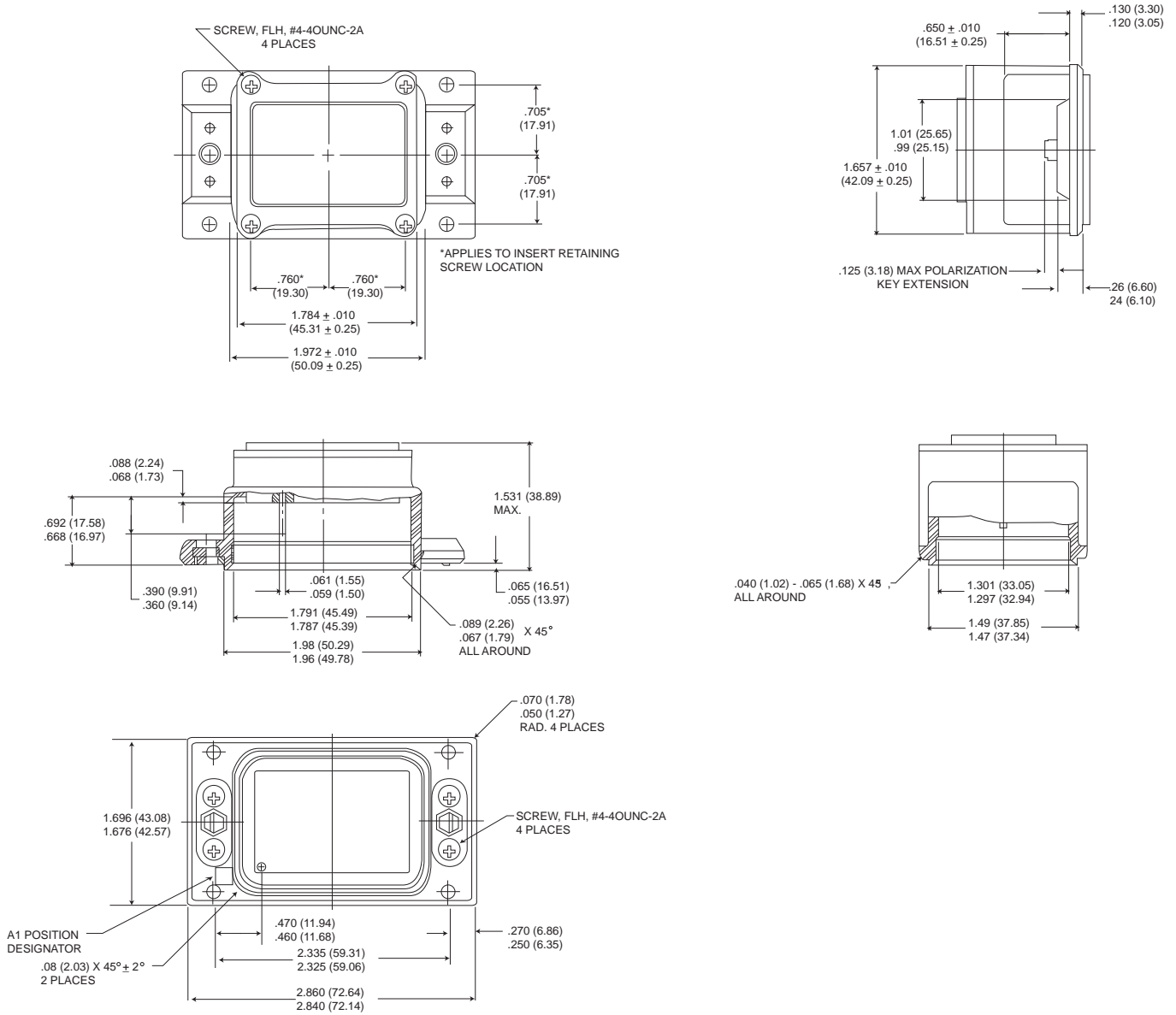

Recommended Panel Cutout

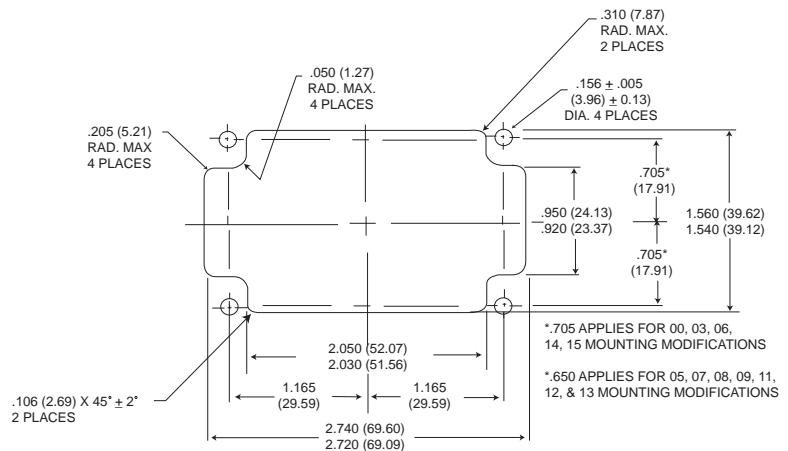

Polarization

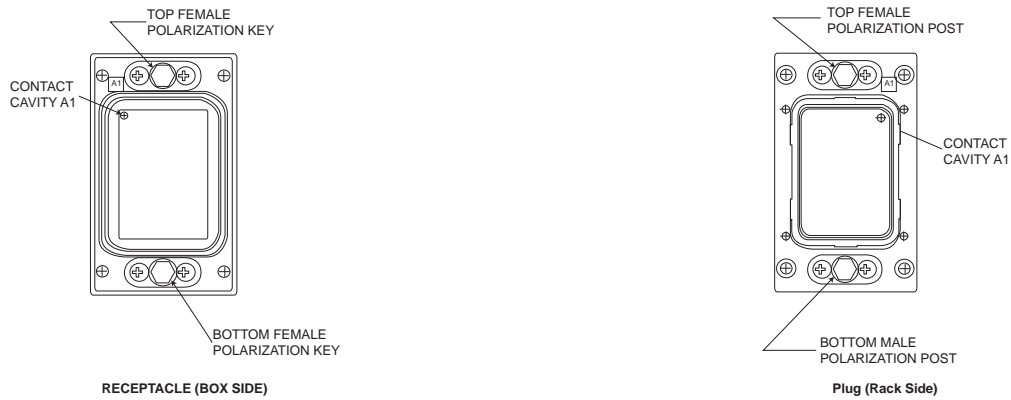

Polarizing Positions

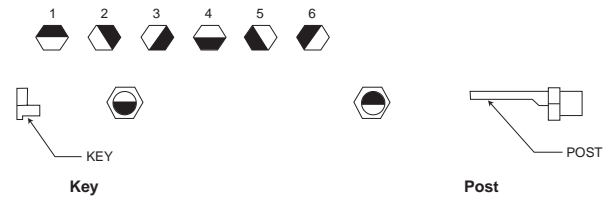

Position	Connector Receptacle		Connector Plug	
	Top Key	Bottom Key	Top Post	Bottom Post
01	1	1	4	4
02	3	4	2	1
03	2	4	3	1
04	1	4	4	1
05	6	4	5	1
06	5	4	6	1
07	4	5	1	6
08	3	5	2	6
09	2	5	3	6
10	1	5	4	6
11	6	5	5	6
12	5	5	6	6
13	4	6	1	5
14	3	6	2	5
15	2	6	3	5
16	1	6	4	5
17	6	6	5	5
18	5	6	6	5
19	4	1	1	4
20	3	1	2	4
21	2	1	3	4
22	4	4	1	1
23	6	1	5	4
24	5	1	6	4
25	4	2	1	3
26	3	2	2	3
27	2	2	3	3
28	1	2	4	3
29	6	2	5	3
30	5	2	6	3
31	4	3	1	2
32	3	3	2	2
33	2	3	3	2
34	1	3	4	2
35	6	3	5	2
36	5	3	6	2