

L to Ku BAND LOW NOISE AMPLIFIER
N-CHANNEL GaAs MES FET

FEATURES

- Low noise figure
NF = 0.6 dB TYP. at f = 4 GHz
- High associated gain
Ga = 14 dB TYP. at f = 4 GHz
- Gate width: $W_g = 280 \mu\text{m}$
- Gate Length: $L_g = 0.3 \mu\text{m}$

ORDERING INFORMATION

PART NUMBER	I_{DSS} (mA)	PACKAGE CODE
NE71300-N	20 to 50	00 (CHIP)
NE71300-M	50 to 80	
NE71300-L	80 to 120	
NE71383B	20 to 120	83B

ABSOLUTE MAXIMUM RATINGS ($T_A = 25^\circ\text{C}$)

Drain to Source Voltage	V_{DS}	5.0	V	
Gate to Source Voltage	V_{GSO}	-5.0	V	
Gate to Drain Voltage	V_{GDO}	-6.0	V	
Drain Current	I_D	I_{DSS}	mA	
Total Power Dissipation	P_{tot}	270	mW	[NE71383B]
		400	mW	[NE71300]
Channel Temperature	T_{ch}	175	$^\circ\text{C}$	
Storage Temperature	T_{stg}	-65 to +175	$^\circ\text{C}$	

RECOMMENDED OPERATING CONDITION ($T_A = 25^\circ\text{C}$)

CHARACTERISTIC	SYMBOL	MIN.	TYP.	MAX.	Unit
Drain to Source Voltage	V_{DS}		3	4	V
Drain Current	I_D		10	30	mA
Input Power	P_{in}			15	dBm

ELECTRICAL CHARACTERISTICS (T_A = 25 °C)

CHARACTERISTIC	SYMBOL	MIN.	TYP.	MAX.	UNIT	TEST CONDITIONS	
Gate to Source Leak Current	I _{GSO}	-	1.0	10	μA	V _{GS} = -5 V	
Saturated Drain Current	I _{DSS}	20	40	120	mA	V _{DS} = 3 V, V _{GS} = 0 V	
Gate to Source Cut off Voltage	V _{GS (off)}	-0.5	-1.1	-3.5	V	V _{DS} = 3 V, I _D = 100 μA	
Transconductance	gm	20	50	-	mS	V _{DS} = 3 V, I _D = 10 mA	
Noise Figure	NF		0.6	0.7	dB	f = 4 GHz V _{DS} = 3 V I _D = 10 mA	
Associated Gain	Ga	11.5	14.0		dB		
Noise Figure	NF		1.6	1.8	dB		f = 12 GHz
Associated Gain	Ga	8.0	9.5		dB		
Output Power at 1 dB Gain Compression Point	P _{o (1 dB)}		14.5		dBm	f = 12 GHz V _{DS} = 3 V I _D = 30 mA	
Thermal Resistance	R _{th}			190	°C/W	NE71300	Channel to case
				450	°C/W	NE71383B	

PACKAGE DIMENSIONS (Unit : mm) [NE71383B]

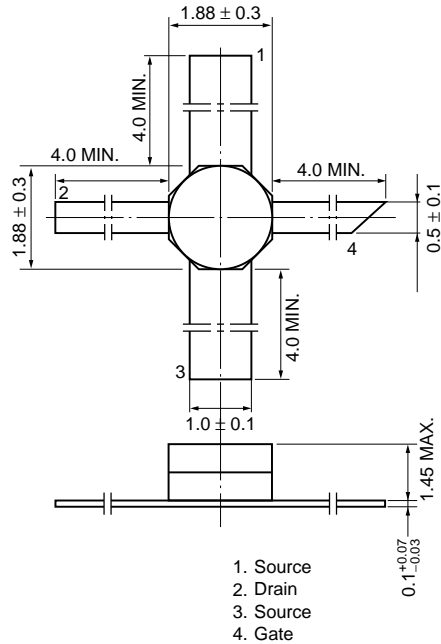

CHIP DIMENSIONS (Unit: μm) [NE71300]

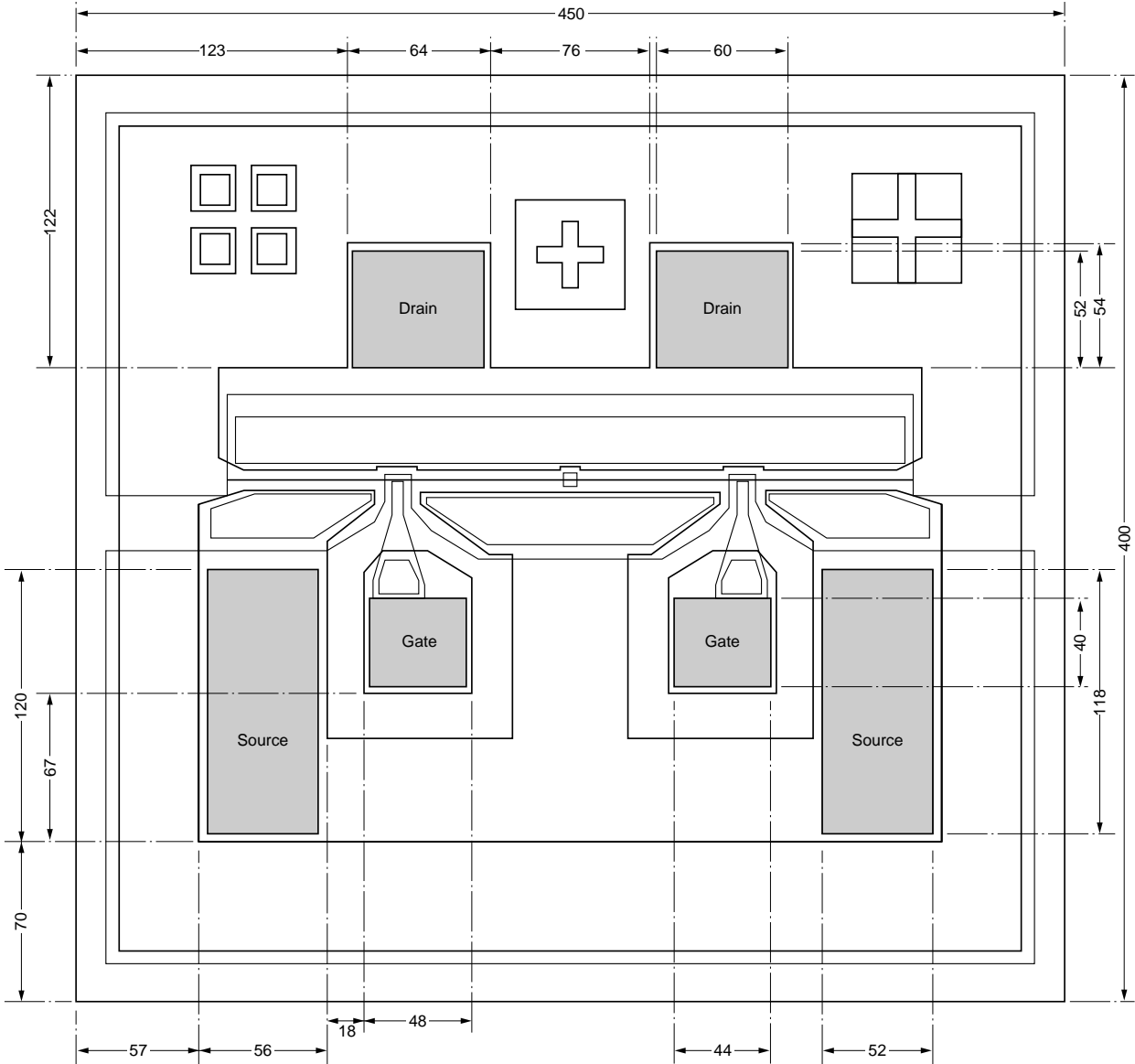

Thickness = 140 μm

 : BONDING AREA

TYPICAL CHARACTERISTICS (T_A = 25 °C)

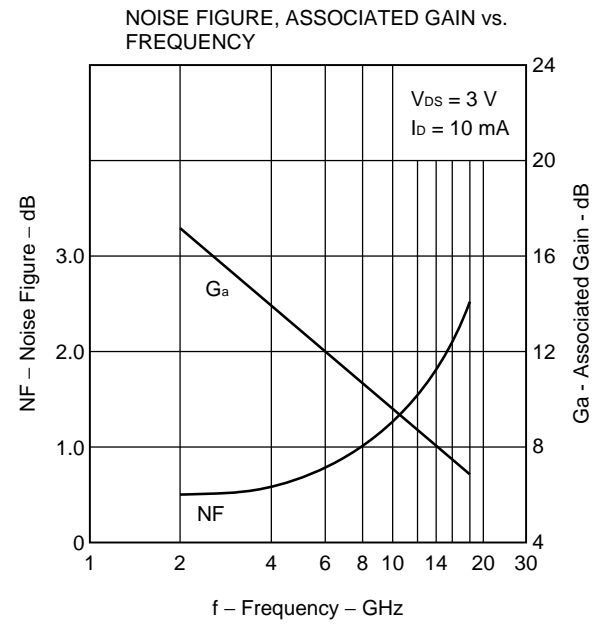
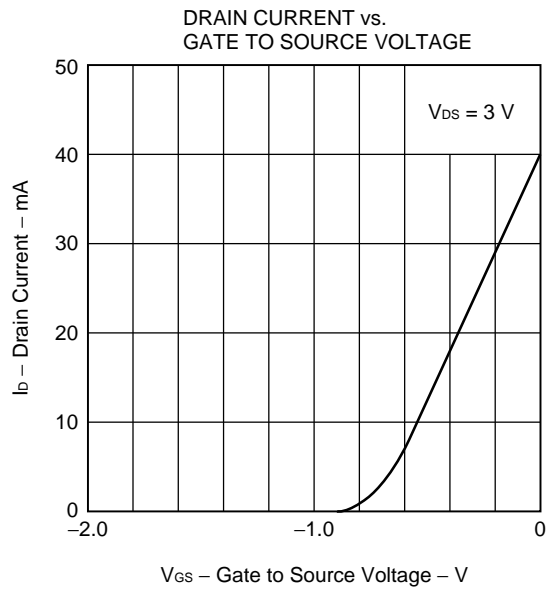
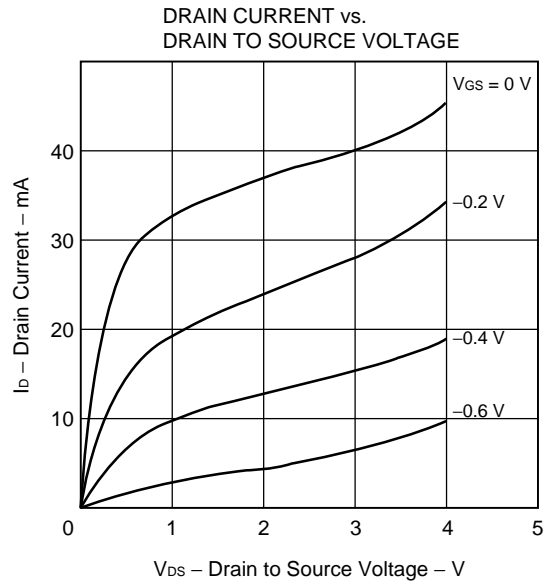
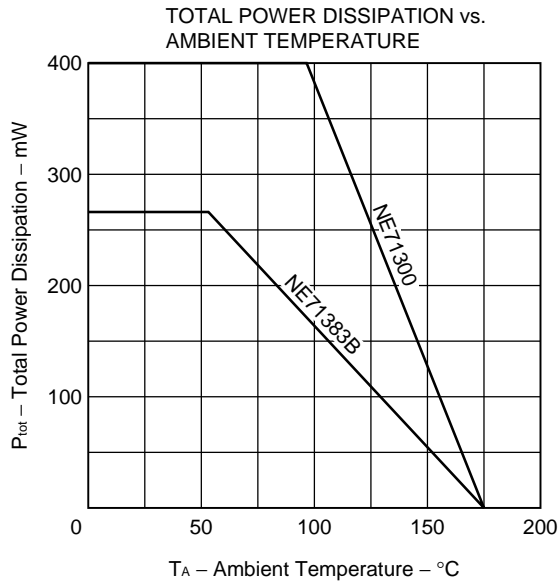

S-PARAMETER [NE71383B]

$V_{DS} = 3\text{ V}$, $I_D = 10\text{ mA}$
START 500 MHz,
STOP 18 GHz,
STEP 500 MHz

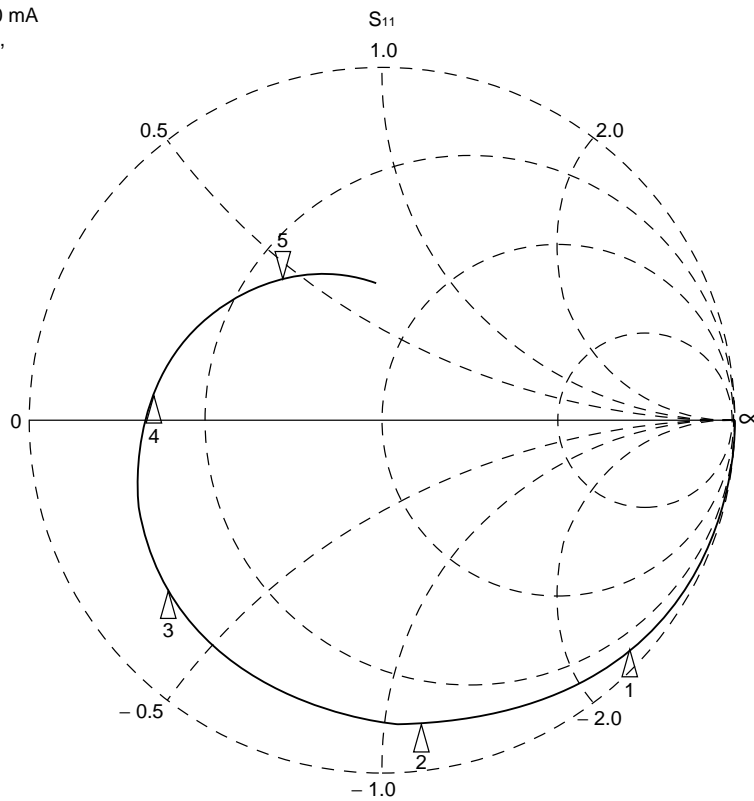

Marker
1 : 2 GHz
2 : 4 GHz
3 : 8 GHz
4 : 12 GHz
5 : 16 GHz

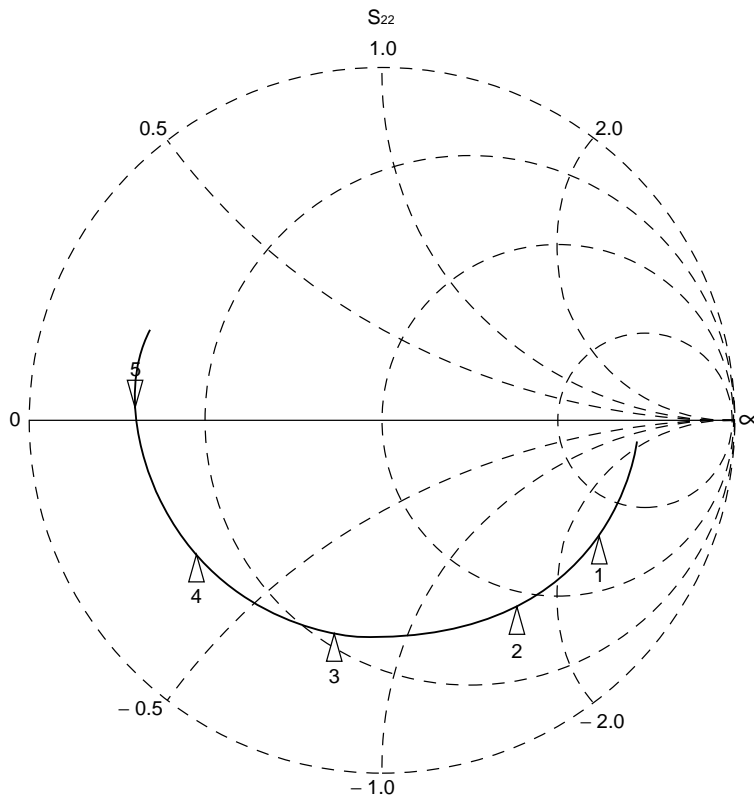

MAG. AND ANG. [NE71383B]

V_{DS} = 3 V, I_D = 10 mA

FREQUENCY MHz	S ₁₁		S ₂₁		S ₁₂		S ₂₂	
	MAG.	ANG. (deg.)	MAG.	ANG. (deg.)	MAG.	ANG. (deg.)	MAG.	ANG. (deg.)
500	.992	-11.4	3.091	169.6	.011	81.8	.729	-6.9
1000	.961	-21.7	3.045	159.3	.022	74.6	.721	-14.0
1500	.985	-32.1	3.029	150.2	.032	67.1	.714	-21.0
2000	.960	-42.5	2.941	141.1	.041	59.8	.709	-27.6
2500	.930	-53.1	2.914	130.6	.049	53.3	.696	-34.1
3000	.934	-61.7	2.795	123.1	.056	46.5	.687	-40.4
3500	.885	-70.6	2.662	113.5	.062	39.6	.672	-47.1
4000	.855	-81.8	2.568	104.4	.068	34.7	.657	-53.6
4500	.876	-89.4	2.537	95.5	.071	29.3	.651	-59.9
5000	.830	-97.3	2.436	88.7	.076	23.4	.637	-66.3
5500	.818	-106.0	2.333	80.9	.077	17.6	.630	-72.4
6000	.817	-111.4	2.251	74.2	.080	14.0	.623	-78.6
6500	.786	-120.2	2.132	66.2	.080	9.3	.613	-84.7
7000	.781	-126.4	2.100	59.2	.081	5.9	.619	-90.5
7500	.772	-133.0	2.028	52.6	.081	1.6	.616	-96.0
8000	.763	-140.2	1.988	44.9	.079	-2.1	.614	-101.6
8500	.752	-145.6	1.929	39.3	.082	-4.4	.619	-106.8
9000	.734	-152.9	1.854	31.6	.080	-7.0	.621	-112.3
9500	.716	-158.2	1.815	25.8	.079	-9.8	.620	-117.7
10000	.695	-164.0	1.758	20.0	.081	-11.3	.618	-122.7
10500	.685	-169.5	1.714	14.1	.079	-14.2	.628	-127.7
11000	.672	-174.5	1.666	7.7	.079	-16.6	.624	-133.5
11500	.661	179.4	1.657	1.2	.080	-18.3	.624	-138.4
12000	.649	174.4	1.624	-4.5	.080	-19.6	.633	-143.9
12500	.633	169.1	1.597	-11.4	.080	-21.6	.629	-149.3
13000	.614	162.3	1.577	-17.3	.082	-24.0	.638	-153.9
13500	.594	156.9	1.542	-24.1	.082	-24.4	.646	-159.1
14000	.567	151.1	1.500	-30.0	.085	-27.7	.651	-164.0
14500	.543	143.5	1.483	-36.1	.088	-28.7	.662	-168.7
15000	.536	138.2	1.462	-41.9	.089	-31.6	.668	-174.0
15500	.512	131.0	1.455	-47.9	.094	-34.7	.670	-178.5
16000	.489	123.7	1.451	-54.1	.097	-37.3	.679	176.3
16500	.465	116.9	1.433	-60.5	.100	-40.8	.681	172.0
17000	.451	108.3	1.441	-67.5	.102	-44.1	.688	167.4
17500	.418	100.7	1.408	-74.6	.106	-48.5	.686	162.6
18000	.387	91.9	1.404	-81.6	.115	-52.0	.690	158.2

AMP. PARAMETERS [NE71383B]

V_{DS} = 3 V, I_D = 10 mA

FREQUENCY	G _U max	G _A max	S ₂₁ ²	S ₁₂ ²	K	Delay	Mason's U	G ₁	G ₂
MHz	dB	dB	dB	dB		ns	dB	dB	dB
500	31.25		9.80	-39.45	.13	.057	32.031	18.15	3.29
1000	23.98		9.67	-33.21	.32	.057	24.912	11.11	3.19
1500	27.96		9.63	-29.94	.12	.051		15.23	3.10
2000	23.47		9.37	-27.78	.21	.051	27.872	11.06	3.03
2500	20.85		9.29	-26.16	.30	.058	25.493	8.69	2.88
3000	20.66		8.93	-25.08	.27	.042	27.620	8.96	2.78
3500	17.75		8.50	-24.21	.44	.053	21.291	6.64	2.60
4000	16.36		8.19	-23.38	.48	.050	21.446	5.72	2.45
4500	16.80		8.09	-22.98	.42	.050	29.940	6.32	2.40
5000	15.07		7.73	-22.42	.54	.038	21.087	5.08	2.26
5500	14.37		7.36	-22.24	.58	.043	20.508	4.81	2.20
6000	13.97		7.05	-21.99	.58	.037	21.963	4.78	2.13
6500	12.80		6.57	-21.94	.70	.044	19.246	4.17	2.05
7000	12.63		6.44	-21.87	.70	.039	21.050	4.09	2.10
7500	12.14		6.14	-21.86	.74	.036	20.299	3.93	2.07
8000	11.82		5.97	-22.01	.78	.043	20.634	3.80	2.05
8500	11.42		5.71	-21.69	.78	.031	22.545	3.62	2.10
9000	10.84		5.36	-21.92	.87	.043	20.735	3.36	2.12
9500	10.41		5.18	-22.00	.95	.032	18.958	3.12	2.10
10000	9.86	12.83	4.90	-21.82	1.01	.033	18.153	2.87	2.09
10500	9.60	11.85	4.68	-22.06	1.06	.033	17.406	2.75	2.17
11000	9.18	11.00	4.43	-22.04	1.13	.036	16.357	2.60	2.14
11500	9.02	10.83	4.39	-21.95	1.15	.036	16.626	2.49	2.14
12000	8.80	10.63	4.21	-21.91	1.16	.032	16.712	2.37	2.22
12500	8.48	10.04	4.07	-21.96	1.24	.038	15.425	2.22	2.19
13000	8.28	9.88	3.96	-21.73	1.24	.033	15.408	2.05	2.27
13500	8.00	9.53	3.76	-21.70	1.28	.038	14.697	1.89	2.35
14000	7.60	8.99	3.52	-21.46	1.34	.033	13.629	1.69	2.39
14500	7.44	8.95	3.42	-21.11	1.31	.034	13.749	1.52	2.50
15000	7.33	8.87	3.30	-21.03	1.30	.032	13.588	1.47	2.56
15500	7.16	8.74	3.26	-20.54	1.28	.033	13.516	1.32	2.58
16000	7.10	8.79	3.23	-20.23	1.24	.034	13.671	1.19	2.68
16500	6.89	8.45	3.13	-20.02	1.27	.036	12.826	1.06	2.70
17000	6.95	8.67	3.17	-19.79	1.22	.039	13.129	.99	2.79
17500	6.57	8.05	2.97	-19.50	1.28	.040	11.786	.83	2.77
18000	6.46	8.06	2.95	-18.80	1.22	.039	11.808	.71	2.80

MAG. AND ANG. [NE71383B]

V_{DS} = 3 V, I_D = 20 mA

FREQUENCY MHz	S ₁₁		S ₂₁		S ₁₂		S ₂₂	
	MAG.	ANG. (deg.)	MAG.	ANG. (deg.)	MAG.	ANG. (deg.)	MAG.	ANG. (deg.)
500	.999	-10.8	3.834	169.5	.010	82.5	.685	-6.8
1000	.998	-21.9	3.746	160.0	.020	73.6	.680	-13.8
1500	.996	-33.4	3.694	149.1	.029	66.4	.667	-20.9
2000	.987	-43.8	3.630	140.2	.037	59.9	.663	-27.4
2500	.968	-54.5	3.552	130.3	.045	54.1	.651	-33.8
3000	.948	-63.8	3.417	121.7	.052	47.6	.638	-40.2
3500	.923	-73.4	3.265	112.5	.056	43.2	.627	-46.7
4000	.890	-84.3	3.107	103.1	.062	36.6	.612	-52.9
4500	.885	-93.2	3.067	93.9	.065	30.5	.605	-59.3
5000	.860	-100.9	2.929	87.3	.067	26.0	.592	-65.4
5500	.840	-109.0	2.804	79.6	.070	21.3	.586	-71.3
6000	.828	-115.7	2.694	72.9	.071	18.9	.580	-77.6
6500	.811	-123.8	2.538	64.7	.073	13.5	.572	-83.4
7000	.797	-130.5	2.500	57.9	.073	10.6	.578	-88.9
7500	.776	-137.6	2.399	51.1	.073	8.4	.575	-94.2
8000	.780	-144.3	2.349	43.6	.074	5.4	.575	-99.8
8500	.754	-150.5	2.271	38.0	.075	2.8	.581	-104.8
9000	.738	-157.3	2.175	29.9	.075	.5	.584	-110.1
9500	.720	-162.7	2.129	24.7	.077	-1.9	.582	-115.2
10000	.693	-169.1	2.050	18.5	.078	-3.4	.585	-120.0
10500	.677	-174.1	1.999	12.7	.077	-5.5	.591	-125.0
11000	.661	-179.3	1.943	6.6	.078	-6.6	.593	-131.1
11500	.649	174.6	1.923	.1	.080	-8.0	.593	-135.6
12000	.627	169.6	1.884	-5.8	.081	-10.2	.600	-141.0
12500	.608	163.6	1.850	-12.6	.083	-12.1	.603	-146.5
13000	.594	157.6	1.820	-18.5	.086	-14.1	.615	-150.9
13500	.563	151.3	1.778	-25.2	.087	-15.9	.621	-156.1
14000	.536	145.7	1.730	-31.3	.092	-19.1	.632	-160.9
14500	.513	138.3	1.708	-37.2	.095	-21.2	.641	-165.7
15000	.499	131.9	1.678	-43.1	.098	-24.1	.648	-170.8
15500	.467	125.3	1.665	-49.4	.103	-27.5	.657	-175.2
16000	.456	117.8	1.654	-55.4	.105	-31.5	.666	179.2
16500	.426	109.8	1.636	-61.9	.111	-34.6	.668	175.0
17000	.401	101.8	1.631	-68.8	.114	-39.1	.683	170.1
17500	.373	92.7	1.599	-76.1	.118	-43.4	.679	165.3
18000	.344	82.3	1.595	-83.0	.125	-49.5	.691	160.4

AMP. PARAMETERS [NE71383B]

V_{DS} = 3 V, I_D = 20 mA

FREQUENCY MHz	G _{Umax} dB	G _{Amax} dB	S ₂₁ ² dB	S ₁₂ ² dB	K	Delay ns	Mason's U dB	G ₁ dB	G ₂ dB
500			11.67	-39.93	.00	.053			2.75
1000			11.47	-33.98	.00	.053			2.70
1500	34.72		11.35	-30.84	.08	.061		20.81	2.56
2000	29.65		11.20	-28.59	.10	.049		15.93	2.52
2500	25.48		11.01	-27.03	.16	.055		12.07	2.40
3000	22.86		10.67	-25.76	.23	.048		9.92	2.27
3500	20.76		10.28	-24.99	.28	.051		8.31	2.17
4000	18.70		9.85	-24.12	.37	.052		6.82	2.04
4500	18.37		9.73	-23.75	.38	.051		6.66	1.98
5000	17.05		9.33	-23.46	.44	.037		5.84	1.87
5500	16.09		8.96	-23.04	.49	.043		5.31	1.83
6000	15.42		8.61	-22.92	.51	.037		5.03	1.78
6500	14.45		8.09	-22.73	.59	.045		4.65	1.72
7000	14.11		7.96	-22.68	.61	.038		4.38	1.76
7500	13.34		7.60	-22.69	.68	.038		4.00	1.74
8000	13.24		7.42	-22.66	.67	.042		4.08	1.74
8500	12.56		7.12	-22.47	.73	.031		3.65	1.79
9000	11.97		6.75	-22.48	.80	.045		3.41	1.81
9500	11.53		6.56	-22.23	.83	.029		3.17	1.80
10000	10.89		6.23	-22.16	.92	.034		2.84	1.82
10500	10.54		6.02	-22.30	.99	.033	25.000	2.66	1.87
11000	10.15	13.04	5.77	-22.13	1.02	.034	23.743	2.50	1.88
11500	9.93	12.69	5.68	-21.93	1.03	.036	24.116	2.38	1.88
12000	9.61	11.95	5.50	-21.82	1.08	.033	21.165	2.17	1.94
12500	9.31	11.43	5.34	-21.66	1.12	.037	19.457	2.01	1.96
13000	9.15	11.48	5.20	-21.35	1.09	.033	20.295	1.89	2.06
13500	8.77	10.74	5.00	-21.19	1.15	.037	17.509	1.65	2.12
14000	8.45	10.42	4.76	-20.73	1.15	.034	16.961	1.47	2.21
14500	8.28	10.29	4.65	-20.47	1.14	.033	16.574	1.33	2.30
15000	8.11	10.24	4.49	-20.16	1.12	.032	16.461	1.24	2.37
15500	7.95	10.10	4.43	-19.73	1.11	.035	16.064	1.07	2.46
16000	7.93	10.30	4.37	-19.56	1.07	.033	16.400	1.01	2.55
16500	7.71	10.01	4.28	-19.09	1.08	.036	15.418	.87	2.56
17000	7.74	10.34	4.25	-18.87	1.04	.038	15.681	.76	2.73
17500	7.41	9.58	4.08	-18.56	1.08	.041	13.963	.65	2.69
18000	7.42	10.05	4.05	-18.08	1.03	.038	14.623	.55	2.82

MAG. AND ANG. [NE71383B]

V_{DS} = 3 V, I_D = 30 mA

FREQUENCY MHz	S ₁₁		S ₂₁		S ₁₂		S ₂₂	
	MAG.	ANG. (deg.)	MAG.	ANG. (deg.)	MAG.	ANG. (deg.)	MAG.	ANG. (deg.)
500	.999	-11.1	4.104	169.4	.009	80.0	.672	-6.7
1000	.998	-22.3	4.015	159.5	.019	75.6	.665	-13.7
1500	.991	-34.0	3.946	148.9	.026	68.0	.655	-20.9
2000	.977	-44.6	3.862	139.7	.035	60.4	.650	-27.2
2500	.962	-55.3	3.789	129.7	.042	54.8	.638	-33.7
3000	.937	-64.9	3.621	121.3	.048	47.9	.625	-39.7
3500	.909	-74.5	3.459	111.8	.053	42.5	.613	-46.4
4000	.878	-85.4	3.291	102.7	.057	38.0	.599	-52.3
4500	.870	-94.5	3.237	93.4	.060	31.2	.592	-58.8
5000	.845	-102.2	3.087	86.8	.062	26.8	.579	-64.8
5500	.824	-110.4	2.951	79.1	.066	24.1	.574	-70.7
6000	.814	-117.0	2.830	72.4	.066	21.3	.568	-76.8
6500	.793	-125.4	2.666	64.4	.067	16.6	.560	-82.6
7000	.780	-131.7	2.622	57.5	.069	14.3	.566	-88.0
7500	.759	-139.0	2.511	50.8	.069	11.4	.563	-93.2
8000	.759	-145.8	2.456	43.2	.069	9.2	.565	V98.7
8500	.738	-151.7	2.376	37.8	.070	6.5	.570	-103.8
9000	.718	-158.5	2.271	29.7	.070	5.1	.574	-109.1
9500	.702	-164.1	2.225	24.5	.073	3.0	.575	-114.2
10000	.676	-170.0	2.139	18.6	.073	2.6	.577	-119.0
10500	.663	-175.2	2.088	12.6	.073	-1	.585	-123.7
11000	.644	179.6	2.029	6.4	.076	-6	.586	-129.9
11500	.630	173.5	2.004	0.0	.078	-2.4	.584	-134.4
12000	.613	168.6	1.958	-5.8	.080	-4.6	.595	-139.9
12500	.594	162.7	1.930	-12.5	.081	-7.0	.599	-145.1
13000	.577	156.7	1.890	-18.3	.085	-7.6	.608	-149.7
13500	.549	150.2	1.850	-25.1	.088	-9.6	.616	-154.8
14000	.523	144.3	1.800	-31.0	.092	-13.3	.626	-159.8
14500	.496	137.0	1.772	-37.1	.096	-16.1	.638	-164.3
15000	.486	131.1	1.741	-42.9	.101	-19.4	.645	-169.7
15500	.455	123.6	1.733	-49.1	.106	-21.7	.653	-174.0
16000	.439	117.0	1.718	-55.1	.106	-26.2	.664	-179.3
16500	.416	108.5	1.693	-61.6	.113	-30.1	.668	176.2
17000	.390	100.0	1.697	-68.5	.118	-34.4	.684	171.5
17500	.364	92.3	1.654	-75.7	.123	-39.2	.679	166.8
18000	.337	80.6	1.652	-82.8	.129	-45.0	.692	162.0

AMP. PARAMETERS [NE71383B]

V_{DS} = 3 V, I_D = 30 mA

FREQUENCY MHz	GUmax dB	GAmax dB	S ₂₁ ² dB	S ₁₂ ² dB	K	Delay ns	Mason's U dB	G1 dB	G2 dB
500			12.26	-40.73	.00	.055			2.61
1000	39.48		12.07	-34.47	.04	.055		24.88	2.53
1500	31.92		11.92	-31.60	.08	.059		17.56	2.43
2000	27.60		11.74	-29.22	.14	.051		13.48	2.39
2500	25.13		11.57	-27.52	.18	.056		11.29	2.27
3000	22.46		11.18	-26.43	.26	.047		9.13	2.15
3500	20.41		10.78	-25.54	.34	.053		7.59	2.05
4000	18.68		10.35	-24.91	.41	.051		6.40	1.93
4500	18.21		10.20	-24.45	.43	.051		6.14	1.87
5000	16.99		9.79	-24.14	.50	.037	39.309	5.42	1.77
5500	16.07		9.40	-23.64	.54	.043		4.93	1.73
6000	15.45		9.04	-23.57	.56	.037		4.72	1.69
6500	14.46		8.52	-23.44	.65	.045		4.30	1.63
7000	14.11		8.37	-23.28	.67	.038		4.06	1.68
7500	13.38		8.00	-23.27	.75	.037		3.72	1.66
8000	13.20		7.80	-23.21	.74	.042		3.72	1.67
8500	12.64		7.52	-23.09	.80	.030		3.42	1.71
9000	12.00		7.12	-23.10	.88	.044		3.15	1.73
9500	11.64		6.95	-22.73	.89	.029		2.94	1.74
10000	11.02		6.60	-22.71	.98	.033	28.158	2.66	1.76
10500	10.73	13.62	6.39	-22.69	1.02	.033	24.518	2.52	1.82
11000	10.30	12.92	6.15	-22.35	1.05	.034	23.530	2.33	1.82
11500	10.05	12.49	6.04	-22.12	1.07	.036	22.373	2.20	1.81
12000	9.79	12.12	5.84	-21.98	1.09	.032	21.192	2.05	1.90
12500	9.53	11.64	5.71	-21.85	1.12	.037	19.307	1.89	1.93
13000	9.29	11.60	5.53	-21.41	1.09	.033	19.599	1.76	2.00
13500	8.97	11.14	5.34	-21.09	1.12	.038	17.945	1.56	2.07
14000	8.65	10.69	5.10	-20.77	1.14	.032	16.843	1.39	2.16
14500	8.46	10.61	4.97	-20.32	1.11	.034	16.683	1.22	2.27
15000	8.32	10.77	4.82	-19.90	1.07	.032	17.092	1.17	2.33
15500	8.20	10.74	4.78	-19.51	1.05	.035	16.470	1.01	2.42
16000	8.16	10.70	4.70	-19.47	1.05	.033	16.143	.93	2.53
16500	7.96	10.68	4.57	-18.98	1.03	.036	15.714	.83	2.56
17000	8.05		4.59	-18.59	.97	.038	16.464	.72	2.73
17500	7.68	10.78	4.37	-18.17	1.01	.040	14.666	.62	2.69
18000	7.72		4.36	-17.80	.96	.039	15.178	.52	2.83

TYPICAL NOISE PARAMETERS ($V_{DS} = 3\text{ V}$, $I_D = 10\text{ mA}$) [NE71383B]

Freq. (GHz)	NF _{opt} (dB)	G _a (dB)	Γ _{opt}		Rn/50
			MAG.	ANG. (deg.)	
2.0	0.55	17.0	0.81	37	0.57
3.0	0.58	15.2	0.75	53	0.51
4.0	0.60	14.0	0.70	69	0.44
5.0	0.71	13.0	0.67	83	0.37
6.0	0.80	12.3	0.65	97	0.31
7.0	0.90	11.6	0.64	111	0.25
8.0	1.00	11.0	0.64	123	0.19
9.0	1.15	10.4	0.64	136	0.14
10.0	1.30	10.0	0.64	148	0.10
11.0	1.45	9.5	0.64	161	0.06
12.0	1.60	9.0	0.63	173	0.05
13.0	1.75	8.6	0.62	-173	0.05
14.0	1.90	8.2	0.60	-159	0.08
15.0	2.04	8.0	0.57	-145	0.15
16.0	2.25	7.6	0.53	-129	0.23
17.0	2.38	7.3	0.46	-113	0.34
18.0	2.55	7.0	0.38	-95	0.44

RECOMMENDED SOLDERING CONDITIONS

The following conditions (see table below) must be met when soldering this product.

Please consult with our sales offices in case other soldering process is used, or in case soldering is done under different conditions.

<TYPES OF SURFACE MOUNT DEVICE>

For more details, refer to our document "SEMICONDUCTOR DEVICE MOUNTING TECHNOLOGY MANUAL" (C10535E)

[NE71383B]

Soldering process	Soldering conditions	Symbol
Partial heating method	Terminal temperature: 230 °C or below, Flow time: 10 seconds or below, Exposure limit*: None	

*: Exposure limit before soldering after dry-pack package is opened.
Storage conditions: 25 °C and relative humidity at 65 % or less.

Note: Do not apply more than a single process at once, except for "Partial heating method."

PRECAUTION: Avoid high static voltage and electric fields, because this device is Hetero Junction field effect transistor with shottky barrier gate.

Caution

**The Great Care must be taken in dealing with the devices in this guide.
The reason is that the material of the devices is GaAs (Gallium Arsenide), which is designated as harmful substance according to the law concerned.
Keep the law concerned and so on, especially in case of removal.**

[MEMO]

[MEMO]

No part of this document may be copied or reproduced in any form or by any means without the prior written consent of NEC Corporation. NEC Corporation assumes no responsibility for any errors which may appear in this document.

NEC Corporation does not assume any liability for infringement of patents, copyrights or other intellectual property rights of third parties by or arising from use of a device described herein or any other liability arising from use of such device. No license, either express, implied or otherwise, is granted under any patents, copyrights or other intellectual property rights of NEC Corporation or others.

While NEC Corporation has been making continuous effort to enhance the reliability of its semiconductor devices, the possibility of defects cannot be eliminated entirely. To minimize risks of damage or injury to persons or property arising from a defect in an NEC semiconductor device, customers must incorporate sufficient safety measures in its design, such as redundancy, fire-containment, and anti-failure features.

NEC devices are classified into the following three quality grades:

"Standard", "Special", and "Specific". The Specific quality grade applies only to devices developed based on a customer designated "quality assurance program" for a specific application. The recommended applications of a device depend on its quality grade, as indicated below. Customers must check the quality grade of each device before using it in a particular application.

Standard: Computers, office equipment, communications equipment, test and measurement equipment, audio and visual equipment, home electronic appliances, machine tools, personal electronic equipment and industrial robots

Special: Transportation equipment (automobiles, trains, ships, etc.), traffic control systems, anti-disaster systems, anti-crime systems, safety equipment and medical equipment (not specifically designed for life support)

Specific: Aircrafts, aerospace equipment, submersible repeaters, nuclear reactor control systems, life support systems or medical equipment for life support, etc.

The quality grade of NEC devices is "Standard" unless otherwise specified in NEC's Data Sheets or Data Books. If customers intend to use NEC devices for applications other than those specified for Standard quality grade, they should contact an NEC sales representative in advance.

Anti-radioactive design is not implemented in this product.