

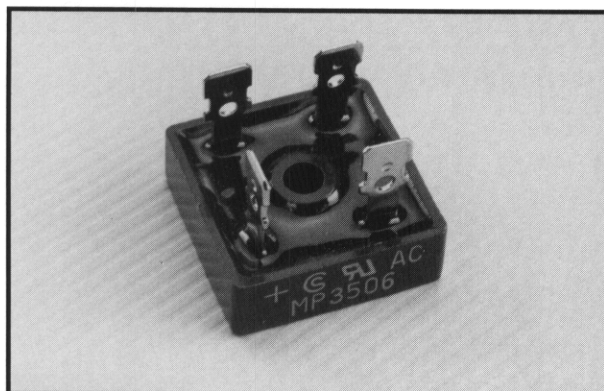

MP35005 Thru MP3510

35 AMP SILICON BRIDGE RECTIFIER



FEATURES

- Rating to 1000V PRV
- 400A surge capability
- High efficiency
- UL recognized: File #E106441

Mechanical Data

- Case: Molded Plastic with heatsink internally mounted in the bridge encapsulation
- Mounting: Through hole for #8 screw
- Weight: 0.7 ounce, 20 grams

Outline Drawing

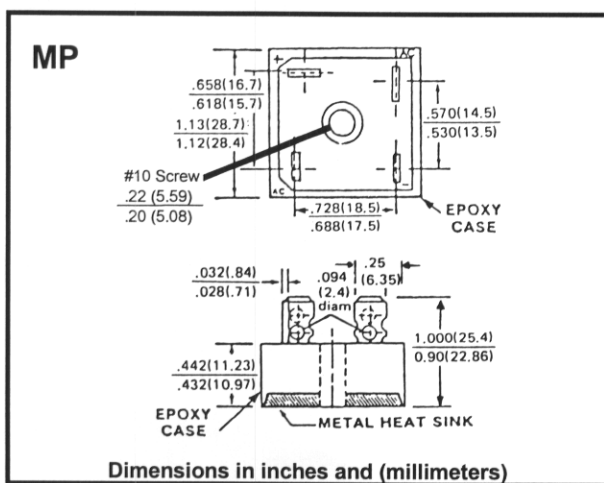

WIRE LEAD (.038 - .042 IN.) Add "W" to end of part number

Maximum Ratings & Characteristics

- Ratings at 25° C ambient temperature unless otherwise specified
- Single phase, half wave, 60Hz, resistive or inductive load
- For capacitive load, derate current by 20%

		MP35005	MP3501	MP3502	MP3504	MP3506	MP3508	MP3510	Units
Maximum Recurrent Peak Reverse Voltage	V _{RRM}	50	100	200	400	600	800	1000	V
Maximum RMS Input Voltage	V _{RMS}	35	70	140	280	420	560	700	V
Maximum DC Blocking Voltage	V _{DC}	50	100	200	400	600	800	1000	V
Maximum Average Forward Output Current @ T _c = 55°C	I _(AV)	35.0							A
Peak Forward Surge Current 8.3 ms Single Half-Sine-Wave Superimposed On Rated Load (JEDEC Method)	I _{FSM}	400							A
Maximum Forward Voltage Drop Per Element At 17.5A	V _F	1.1							V
Maximum Reverse Current At Rated DC Blocking Voltage per Element @ T _A = 25°C @ T _A = 100°	I _R	10 500							μA
I ² t Rating for Fusing (t < 8.3ms)	I ² t	664							A ² S
Typical Thermal Resistance (Note 1)	R _{THJC}	2.0							°C/W
Operating Temperature Range	T _J	-55 to +125							°C
Storage Temperature Range	T _{STG}	-55 to +150							°C

Note: 1. Mounted on a 11.8 in. ² X 0.06 in. thick (300mm² X 1.5MM thick) copper plate