

Features and Benefits

- Small package (SOIC16)
- Current limitation
- Low power consumption
- Thermal Overload protection
- Microcontroller compatible

Applications

- Small DC inductive motor driver
- Lamp driver

Ordering Information

Part No. Temperature Suffix
MLX10402 C

Package
DF (SOIC 16)

Temperature Range
± 0°C to 70°C

Functional Diagram

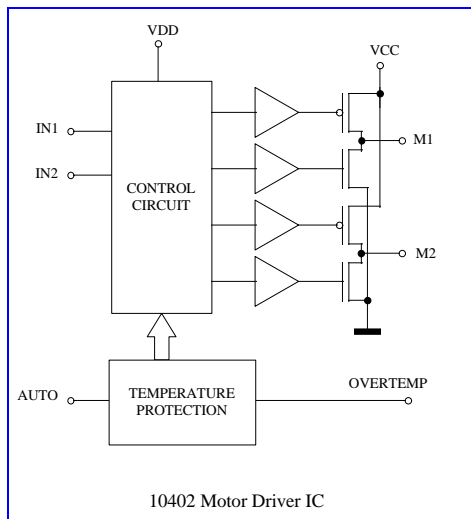

Description

The IC drives directly small DC inductive or active loads like electric motors, lamps, etc. There are four main driving modes. These are set by digital inputs “In1” and “In2” :

IN1	IN2	M1	M2	Driving Mode
1	0	1	0	Forward
0	1	0	1	Reverse
1	1	0	0	Brake (Motor shorted)
0	0	Z	Z	Off (Motor disabled)

The current of the output-drivers is limited for all kinds of overload- and short-circuit conditions and in the whole supply voltage- and temperature range.

The outputs “M1” and “M2” need to be off-chip protected with against motor inductances by standard Si-diodes.

If the temperature of the chip exceeds a certain value (changable with pin “Auto”), the temperature-overload protection-circuit disables the outputs, preventing the chip from being overheated. In addition, this so called “temp ov!”-state is signaled with a low level at the “overtemp”-pin.

Electrical Characteristics

Following characteristics are valid at $\pm 0^{\circ}\text{C}$ to 70°C

Characteristics	Test Conditions	Limits			Units
		Min	Typ	Max	
Supply voltage Vcc		5	9	12	V
Supply voltage Vdd		4.5	5.0	5.5	V
Mean motor current	Vcc=9V	330			mA
	Vcc=6V	300			mA
Motor current limit	Vcc=9V			550	mA
	Vcc=6V			500	mA
Brake current	Vcc=9V	240			mA
	Vcc=6V	180			mA
Voltage drop at the 2 output transistors together	Vcc=9V, Icc=300mA			1.2	V
	Vcc=6V, Icc=260mA			1.2	V
Supply current Icc	FORW, REVERSE, BRAKE, TEMP OVL			5.0	mA
	OFF mode			10.0	μA
Supply current Idd	FORW, REVERSE, BRAKE, TEMP OVL			1.0	mA
	OFF mode			10.0	μA
Inputs "In1" & "In2"	Logic level		TTL, 1.4		V
Input "Auto" (Pull up)	Current sourced (if tied to GND)			25	μA
Output "overtemp" (Open DRAIN)	TEMP OK output			HiZ	
	TEMP OVL output @1mA sink			0.4	V

Temperature characteristics

Characteristics	Conditions	Limits			Units
		Min	Typ	Max	
TEMP OVL-Protection turn on Temperature	"Auto" = 1 or floating		122		$^{\circ}\text{C}$
	"Auto" = 0		155		$^{\circ}\text{C}$
TEMP OVL-Protection turn off Temperature	"Auto" = 1 or floating		93		$^{\circ}\text{C}$
	"Auto" = 0		105		$^{\circ}\text{C}$

Absolute Maximum Ratings

Vcc	+16V
Maximum Output Current	700mA
Die Temperature	+160 $^{\circ}\text{C}$
Storage Temperature	-55 $^{\circ}\text{C}$ to 125 $^{\circ}\text{C}$

Pin-out

Pin 1: M2	Pin 16: AUTO
Pin 2: VCC	Pin 15: N.C.
Pin 3: N.C.	Pin 14: GND (logic)
Pin 4: GND	Pin 13: OVERTEMP
Pin 5: GND	Pin 12: VDD
Pin 6: N.C.	Pin 11: N.C.
Pin 7: VCC	Pin 10: IN1
Pin 8: M1	Pin 9: IN2

Note: N.C. = must be "not connected".

Typical application circuit

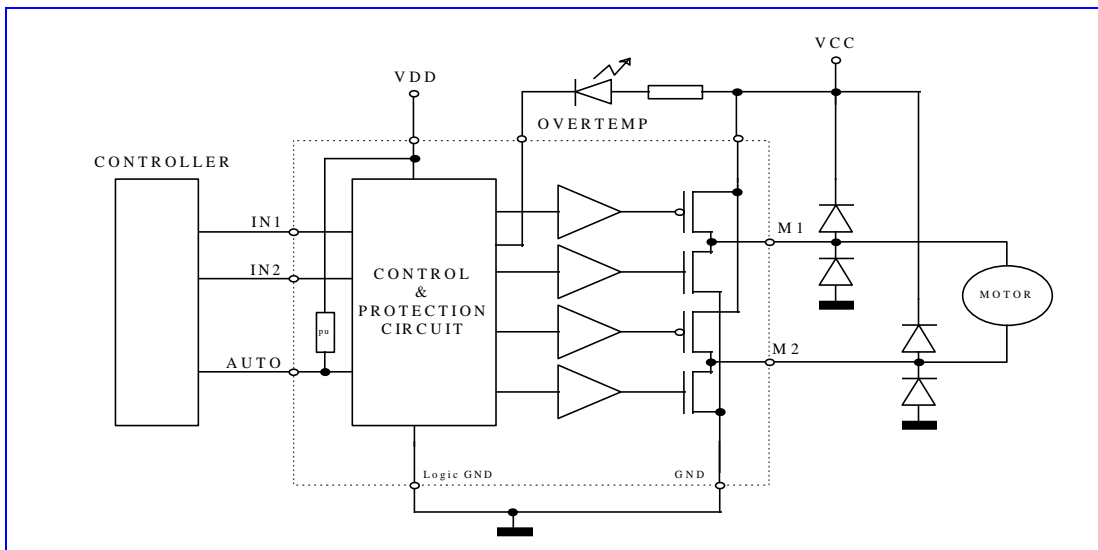

Revision Table

No	Changes
1.0	
002	Conversion to Melexis lay-out standards

For the latest version of this document, go to our website at:

www.melexis.com

Or for additional information contact Melexis Direct:

Europe and Japan: Phone: +32 13 61 16 31 E-mail: sales_europe@melexis.com	All other locations: Phone: +1 603 223 2362 E-mail: sales_usa@melexis.com
---	--

QS9000, VDA6.1 and ISO14001 Certified