

16-bit Proprietary Microcontroller

CMOS

F²MC-16L MB90610A Series

MB90611A/MB90613A

■ DESCRIPTION

MB90610A series includes 16-bit microcontrollers optimally usable for high-speed real-time data processing in consumer appliances and for system control of printer, CD-ROM, cellular phone, copier, etc. The series uses the *F²MC-16L CPU which is based on the F²MC-16 but with enhanced high-level language and task switching instructions and additional addressing modes.

The internal peripheral resources consist of a 3-channel serial port incorporating a UART function (and supporting I/O expansion serial mode), 8-channel 10-bit A/D converter, 2-channel PPG, 2-channel 16-bit reload timer, 8-channel chip select output, and 8-channel external interrupts.

Also, multiplexed or non-multiplexed operation can be selected for the address/data bus.

*: "F²MC is an abbreviation for "Fujitsu Flexible Microcontroller".

■ FEATURES

- F²MC-16L CPU
- Minimum instruction execution time: 62.5 ns/4 MHz oscillation (Uses PLL clock multiplication), maximum multiplier = 4
- Instruction set optimized for controller applications
 - Upward object code compatibility with F²MC-16 (H)
 - Wide range of data types (bit/byte/word/long word)
 - Improved instruction cycles provide increased speed
 - Additional addressing modes: 23 modes
 - High code efficiency
 - Access methods (bank access/linear pointer)
 - Enhanced multiplication and division instructions (signed instructions added)
 - High precision operations are enhanced by use of a 32-bit accumulator
 - Extended intelligent I/O service (access area extended to 64 Kbytes)
 - Maximum memory space: 16 Mbytes

(Continued)

■ PACKAGE

100-pin Plastic LQFP

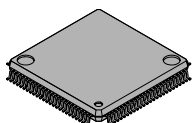

(FPT-100P-M05)

100-pin Plastic QFP

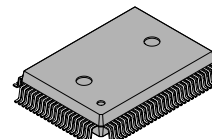

(FPT-100P-M06)

MB90610A Series

(Continued)

- Enhanced high level language (C)/multitasking support instructions
 - Use of a system stack pointer
 - Enhanced pointer indirect instructions
 - Barrel shift instructions
 - Stack check function
- Improved execution speed: Four byte instruction queue
- Powerful interrupt function
- Automatic data transfer function (does not use instructions)

Internal peripherals

- RAM: 1 Kbyte (MB90611A) 3 Kbytes (MB90613A)
- General purpose ports 8, 16-bit data bus, multiplexed mode : 57 ports max.
 - 16-bit non-multiplexed mode : 41 ports max.
 - 8-bit non-multiplexed mode : 49 ports max.
- UART (SCI): 3 channels
 - For either asynchronous or clocked serial transfer (I/O expansion serial)
- A/D converter: 8 channels (10-bit)
 - 8-bit conversion mode also available
- PPG (programmable pulse generator): 2 channels
- 16-bit reload timer: 2 channels
- Chip select output: 8 channels
- External interrupts: 8 channels
- 18-bit timebase timer
 - Watchdog timer function
- PLL clock multiplier function
- CPU intermittent operation function
- Various standby modes
- LQFP-100/QFP-100 package
- CMOS technology

MB90610A Series

■ PRODUCT LINEUP

Part No. Parameter	MB90611A	MB90613A
Classification	Mask ROM	
ROM size	—	
RAM size	1 Kbyte	3 Kbytes
CPU functions	Number of basic instructions : 340 Instruction bit length : 8/16 bits Instruction length : 1 to 7 bytes Data bit length : 1/4/8/16/32 bits Minimum instruction execution time : 62.5 ns/4 MHz (PLL multiplier = 4) Interrupt processing time : 1000 ns/16 MHz (minimum)	
Ports	I/O ports (CMOS/TTL) : 33 (31 CMOS/2 TTL) (N-channel open drain): 8 (16-bit non-multiplex mode) Total : 41	
Packages	FPT-100P-M05 FPT-100P-M06	
UART (SCI)	Three internal UARTs Full-duplex, double-buffered Selectable clock synchronous or asynchronous operation Built-in dedicated baud rate generator	
A/D Converter	10-bit × 8 channels A/D conversion time : 6.13 μs (98 machine cycles/16 MHz machine clock, includes sample and hold time) Triggers : Software, external, or multi-function timer output (RT0) activation can be selected. Activation modes : Single, scan (continuous conversion of multiple channels), continuous (continuous conversion of one channel), and stop (scan mode with synchronized conversion start)	
PPG	2 × 8-bit PPG outputs (1 channel PPG output in 16-bit mode)	
16-Bit Reload Timer	16-bit reload timer operation (selectable toggle output, one-shot output) (Selectable count clock: 0.125 μs, 0.5 μs, or 2.0 μs for a 16 MHz machine cycle) Selectable event count function, 2 internal channels	
Chip select	8 outputs	
External interrupts	8 inputs External interrupt mode (Interrupts can be generated from four different types of request signal)	
PLL Function	Selectable multiplier: 1/2/3/4 (Set a multiplier that does not exceed the assured operation frequency range.)	
Other	—	

MB90610A Series

■ PIN DESCRIPTION

Pin no.		Pin name	Circuit type	Function
LQFP*1	QFP*2			
80 81	82 83	X0 X1	A (Oscillator)	Crystal oscillator pins
83 to 90	85 to 92	D00 to D07	K (TTL)	In non-multiplex mode, the I/O pins for the lower 8 bits of the external data bus.
		AD00 to AD07		In multiplexed mode, the I/O pins for the lower 8 bits of the external address/data bus.
91 to 98	93 to 100	P10 to P17	K (TTL)	General purpose I/O ports This applies in non-multiplexed mode with an 8-bit external data bus.
		P08 to D15		In non-multiplexed mode, the I/O pins for the upper 8 bits of the external data bus This applies when using a 16-bit external data bus.
		AD08 to AD15		In multiplexed mode, the I/O pins for the upper 8 bits of the external address/data bus.
99 100 1 to 6	1 to 8	P20 to P27	B (CMOS)	General purpose I/O ports This applies in multiplexed mode.
		A00 to A07		In non-multiplexed mode, the output pins for the lower 8 bits of the external address bus.
7 8 10 to 15	9 10 12 to 17	P30 to P37	B (CMOS)	General purpose I/O ports This applies in multiplexed mode.
		A08 to A15		In non-multiplexed mode, the output pins for the upper 8 bits of the external address bus.
16 to 20 22 to 24	18 to 22 24 to 26	P40 to P47	B (CMOS)	General purpose I/O ports This applies when the upper address control register specifies port operation.
		A16 to A23		The output pins for A16 to 23 of the external address bus This applies when the upper address control register specifies address operation.
25 to 28	27 to 30	P70 to P73	H (CMOS/H)	General purpose I/O ports This applies in all cases.
		INT0 to INT3		External interrupt request input pins As the inputs operate continuously when external interrupts are enabled, output to the pins from other functions must be stopped unless done intentionally.

*1: FPT-100P-M05

*2: FPT-100P-M06

(Continued)

MB90610A Series

Pin no.		Pin name	Circuit type	Function
LQFP*1	QFP*2			
29 30	31 32	P74, P75	H (CMOS/H)	General purpose I/O ports This applies when the waveform outputs for PPG timers 0 to 1 are disabled.
		INT4, INT5		External interrupt request input pins As the inputs operate continuously when external interrupts are enabled, output to the pins from other functions must be stopped unless done intentionally.
		PPG0, PPG1		Output pins for PPG timers 0 to 1 This applies when the waveform outputs for PPG timers 0 to 1 are enabled.
31	33	P76	H (CMOS/H)	General purpose I/O port This applies in all cases.
		INT6		External interrupt request input pin As the input operates continuously when the external interrupt is enabled, output to the pin from other functions must be stopped unless done intentionally.
		$\overline{\text{ATG}}$		Trigger input pin for the A/D converter As the input operates continuously when the A/D converter inputs are operating, output to the pin from other functions must be stopped unless done intentionally.
32	34	AV _{cc}	Power supply	Power supply for the analog circuits Do not switch this power supply on/off unless a voltage greater than AV _{cc} is applied to V _{cc} .
33	35	AVRH	Power supply	Analog circuit reference voltage input Do not switch the voltage to this pin on/off unless a voltage greater than AVRH is applied to AV _{cc} .
34	36	AVRL	Power supply	Analog circuit reference voltage input
35	37	AV _{ss}	Power supply	Ground level for the analog circuits
36 to 39 41 to 44	38 to 41 43 to 46	P60 to P67	C (AD)	Open-drain output ports This applies when port operation is specified in the analog input enable register.
		AN0 to AN7		Analog input pins for the A/D converter This applies when analog input mode operation is specified in the analog input enable register.
45	47	P80	H (CMOS/H)	General purpose I/O port This applies in all cases.
		INT7		External interrupt request input pin As the input operates continuously when the external interrupt is enabled, output to the pin from other functions must be stopped unless done intentionally.
		TIN0		Event input pin for reload timer 0 As the input operates continuously when the reload timer is set to input operation, output to the pin from other functions must be stopped unless done intentionally.

*1: FPT-100P-M05

*2: FPT-100P-M06

(Continued)

MB90610A Series

Pin no.		Pin name	Circuit type	Function
LQFP*1	QFP*2			
46	48	P81	D (CMOS/H)	General purpose I/O port This applies in all cases.
		TIN1		Event input pin for reload timer 1 As the input operates continuously when the reload timer is set to input operation, output to the pin from other functions must be stopped unless done intentionally.
47, 48	49, 50	MD0, MD1	E (CMOS/H)	Input pins for specifying an operating mode Connect directly to V _{CC} or V _{SS} .
49	51	MD2	M (CMOS/H)	Input pins for specifying an operating mode Connect directly to V _{CC} or V _{SS} .
50	52	$\overline{\text{HST}}$	F (CMOS/H)	Hardware standby input pin
51, 52	53, 54	P82, P83	D (CMOS/H)	General purpose I/O ports This applies when output is disabled for reload timers 0 to 1.
		TOT0, TOT1		Output pins for reload timers 0 to 1 This applies when output is enabled for reload timers 0 to 1.
53	55	P84	D (CMOS/H)	General purpose I/O port This applies in all cases.
		SIN0		Serial data input pin for UART0 As the input operates continuously when UART0 is set to input operation, output to the pin from other functions must be stopped unless done intentionally.
54	56	P85	D (CMOS/H)	General purpose I/O port This applies when serial data output is disabled for UART0.
		SOT0		Serial data output pin for UART0 This applies when serial data output is enabled for UART0.
55	57	P86	D (CMOS/H)	General purpose I/O port This applies when the UART0 clock output is disabled.
		SCK0		Clock I/O pin for UART0 This applies when the UART0 clock output is enabled. As the input operates continuously when UART0 is set to input operation, output to the pin from other functions must be stopped unless done intentionally.
56	58	P90	D (CMOS/H)	General purpose I/O port This applies in all cases.
		SIN1		Serial data input pin for UART1 As the input operates continuously when UART1 is set to input operation, output to the pin from other functions must be stopped unless done intentionally.

*1: FPT-100P-M05

*2: FPT-100P-M06

(Continued)

MB90610A Series

Pin no.		Pin name	Circuit type	Function
LQFP*1	QFP*2			
57	59	P91	D (CMOS/H)	General purpose I/O port This applies when serial data output is disabled for UART1.
		SOT1		Serial data output pin for UART1 This applies when serial data output is enabled for UART1.
58	60	P92	D (CMOS/H)	General purpose I/O port This applies when the UART1 clock output is disabled.
		SCK1		Clock I/O pin for UART1 This applies when the UART1 clock output is enabled. As the input operates continuously when UART1 is set to input operation, output to the pin from other functions must be stopped unless done intentionally.
59	61	P93	D (CMOS/H)	General purpose I/O port This applies in all cases.
		SIN2		Serial data input pin for UART2 As the input operates continuously when UART2 is set to input operation, output to the pin from other functions must be stopped unless done intentionally.
60	62	P94	D (CMOS/H)	General purpose I/O port This applies when serial data output is disabled for UART2.
		SOT2		Serial data output pin for UART2 This applies when serial data output is enabled for UART2.
61	63	P95	D (CMOS/H)	General purpose I/O port This applies when the UART2 clock output is disabled.
		SCK2		Clock I/O pin for UART2 This applies when the UART2 clock output is enabled. As the input operates continuously when UART2 is set to input operation, output to the pin from other functions must be stopped unless done intentionally.
62	64	CS0	J (CMOS)	Chip select pin for program ROM
63 to 69	65 to 71	PA1 to PA7	I (CMOS)	General purpose I/O ports This applies for pins with chip select output disabled by the chip select control register.
		CS1 to CS7		Output pins for the chip select function This applies for pins with chip select output enabled by the chip select control register.
70	72	P50	I (CMOS)	General purpose I/O port This applies when CLK output is enabled.
		CLK		CLK output pin

*1: FPT-100P-M05

*2: FPT-100P-M06

(Continued)

MB90610A Series

(Continued)

Pin no.		Pin name	Circuit type	Function
LQFP*1	QFP*2			
71	73	P51	L (TTL)	General purpose I/O port This applies when the external ready function is disabled.
		RDY		Ready input pin This applies when the external ready function is enabled.
72	74	P52	I (CMOS)	General purpose I/O port This applies when the hold function is disabled.
		$\overline{\text{HAK}}$		Hold acknowledge output pin This applies when the hold function is enabled.
73	75	P53	L (TTL)	General purpose I/O port This applies when the hold function is disabled.
		HRQ		Hold request input pin This applies when the hold function is enabled.
74	76	P54	I (CMOS)	General purpose I/O port This applies in 8-bit external bus mode or when output is disabled for the WR pin.
		$\overline{\text{WRH}}$		Write strobe output pin for the upper 8 bits of the data bus This applies in 16-bit external bus mode and when output is enabled for the WR pin.
75	77	$\overline{\text{RST}}$	G (CMOS/H)	External reset request input pin
76	78	P55	I (CMOS)	General purpose I/O port This applies when output is disabled for the WR pin.
		$\overline{\text{WRL}}$		Write strobe output pin for the lower 8 bits of the data bus This applies when output is enabled for the WR pin.
77	79	$\overline{\text{RD}}$	J (CMOS)	Read strobe output pin for the data bus
78	80	ALE	J (CMOS)	ALE (address latch enabling) output pin
21, 82	23, 84	V _{cc}	Power supply	Power supply for the digital circuits
9, 40, 79	11, 42, 81	V _{ss}	Power supply	Ground level for the digital circuits

*1: FPT-100P-M05

*2: FPT-100P-M06

■ I/O CIRCUIT TYPE

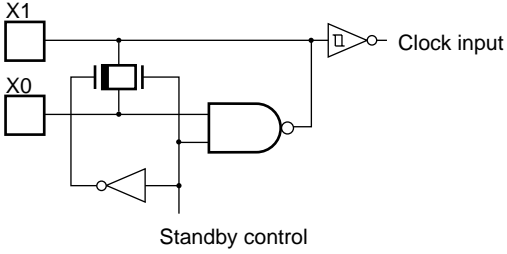
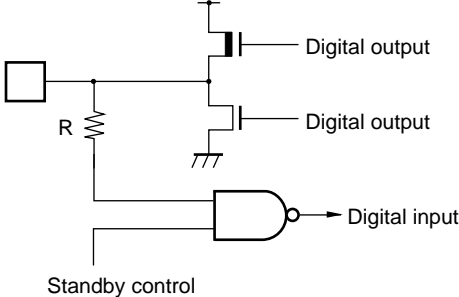
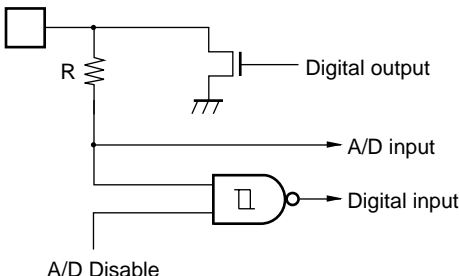
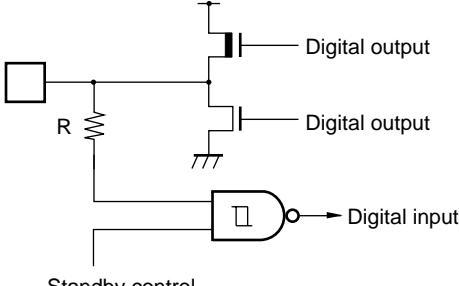
Type	Circuit	Remarks
A	 <p style="text-align: center;">Standby control</p>	<ul style="list-style-type: none"> • Max. 3 to 32 MHz • Oscillator feedback resistance: approximately 1 MΩ
B	 <p style="text-align: center;">Standby control</p>	<ul style="list-style-type: none"> • CMOS level I/O • With standby control
C	 <p style="text-align: center;">A/D Disable</p>	<ul style="list-style-type: none"> • N-channel open drain output • CMOS level hysteresis input • With AD control
D	 <p style="text-align: center;">Standby control</p>	<ul style="list-style-type: none"> • CMOS level output • CMOS level hysteresis input • With standby control

Note: For pins with pull-up resistors, the resistance is disconnected when the pin outputs the “L” level or when in the standby state.

(Continued)

MB90610A Series

Type	Circuit	Remarks
E		<ul style="list-style-type: none"> • CMOS level input • No standby control
F		<ul style="list-style-type: none"> • CMOS level hysteresis input • No standby control
G		<ul style="list-style-type: none"> • CMOS level hysteresis input • No standby control • With pull-up
H		<ul style="list-style-type: none"> • CMOS level output • CMOS level hysteresis input • No standby control
I		<ul style="list-style-type: none"> • CMOS level I/O • Pull-up resistor approximately 50 kΩ • Pin goes to high impedance during stop mode.

Note: For pins with pull-up resistors, the resistance is disconnected when the pin outputs the "L" level or when in the standby state.

(Continued)

MB90610A Series

(Continued)

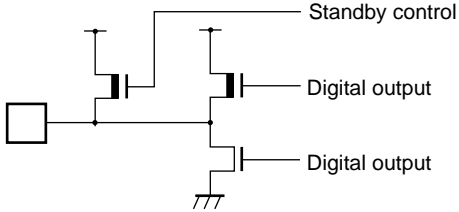
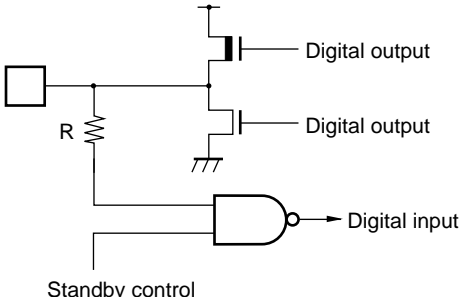
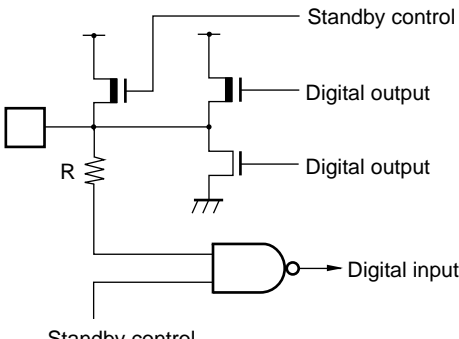
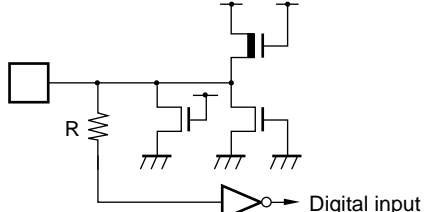
Type	Circuit	Remarks
J		<ul style="list-style-type: none"> • CMOS level output • Pull-up resistor approximately 50 kΩ • Pin goes to high impedance during stop mode.
K		<ul style="list-style-type: none"> • CMOS level output • TTL level input With standby control
L		<ul style="list-style-type: none"> • CMOS level output • TTL level input • Pull-up resistor approximately 50 kΩ • Pin goes to high impedance during stop mode.
M		<ul style="list-style-type: none"> • CMOS level input No standby control

Note: For pins with pull-up resistors, the resistance is disconnected when the pin outputs the “L” level or when in the standby state.

MB90610A Series

■ HANDLING DEVICES

1. Preventing Latchup

Latchup occurs in a CMOS IC if a voltage greater than V_{CC} or less than V_{SS} is applied to an input or output pin or if the voltage applied between V_{CC} and V_{SS} exceeds the rating.

If latchup occurs, the power supply current increases rapidly resulting in thermal damage to circuit elements. Therefore, ensure that maximum ratings are not exceeded in circuit operation.

For the same reason, also ensure that the analog supply voltage does not exceed the digital supply voltage.

2. Treatment of Unused Pins

Leaving unused input pins unconnected can cause misoperation. Always pull-up or pull-down unused pins.

3. External Reset Input

To reliably reset the controller by inputting an “L” level to the \overline{RST} pin, ensure that the “L” level is applied for at least five machine cycles. Take particular note when using an external clock input.

4. V_{CC} and V_{SS} Pins

Ensure that all V_{CC} pins are at the same voltage. The same applies for the V_{SS} pins.

5. Cautions When Using an External Clock

Drive the X0 pin only when using an external clock.

• Using an External Clock

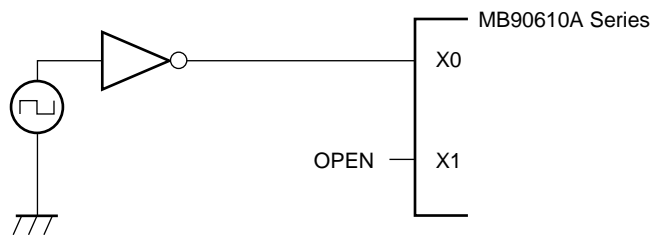

6. A/D Converter Power Supply and the Turn-on Sequence for Analog Inputs

Always cut the A/D converter power supply (AV_{CC} , AV_{RH} , AV_{RL}) and analog inputs (AN0 to AN7) before disconnecting the digital power supply (V_{CC}).

When turning the power on or off, ensure that AV_{RH} does not exceed AV_{CC} .

Also, when using the analog input pins as input ports, ensure that the input voltage does not exceed AV_{CC} .

■ BLOCK DIAGRAM

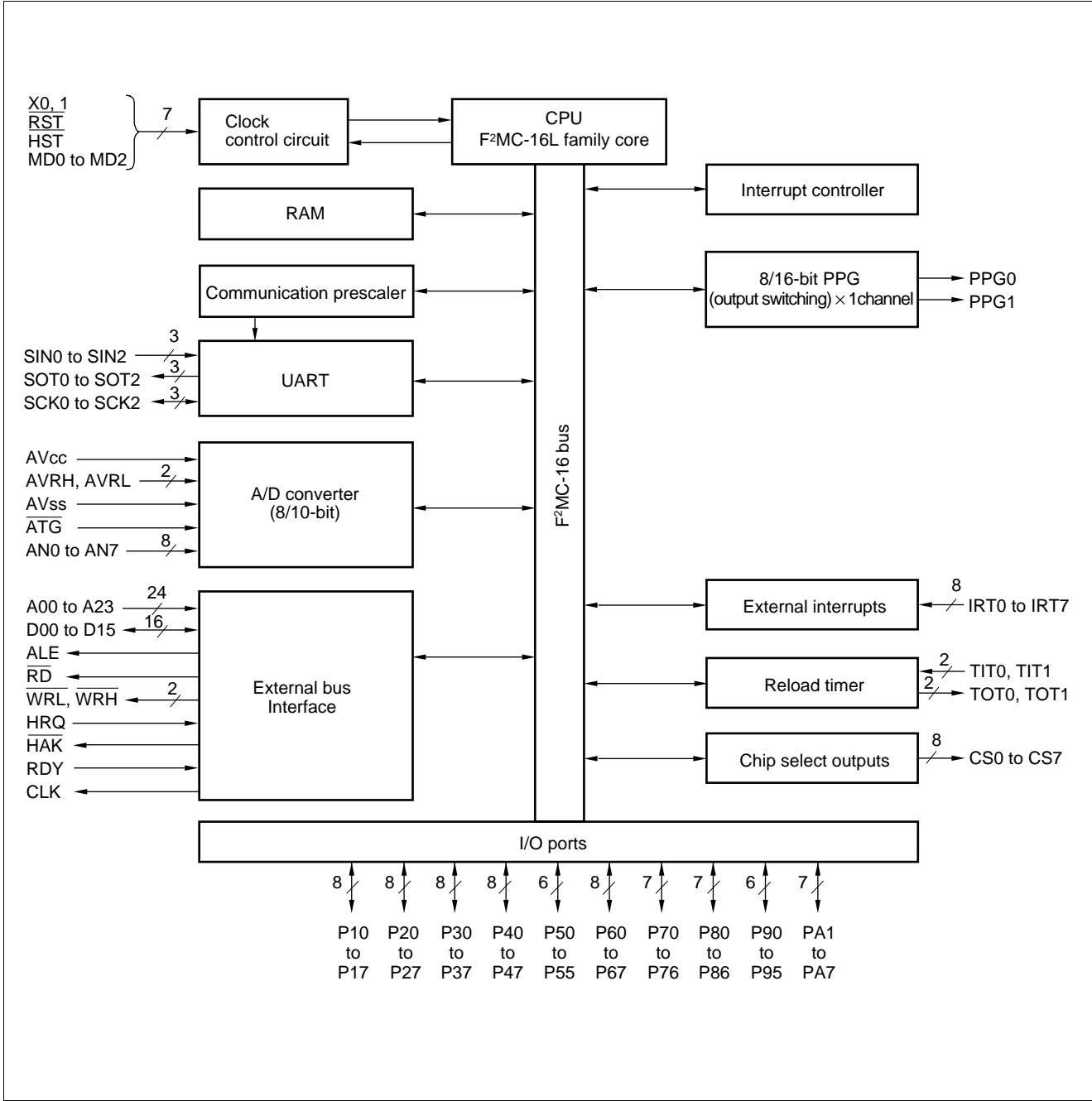

MB90610A Series

■ F²MC-16L CPU PROGRAMMING MODEL

• Dedicated Registers

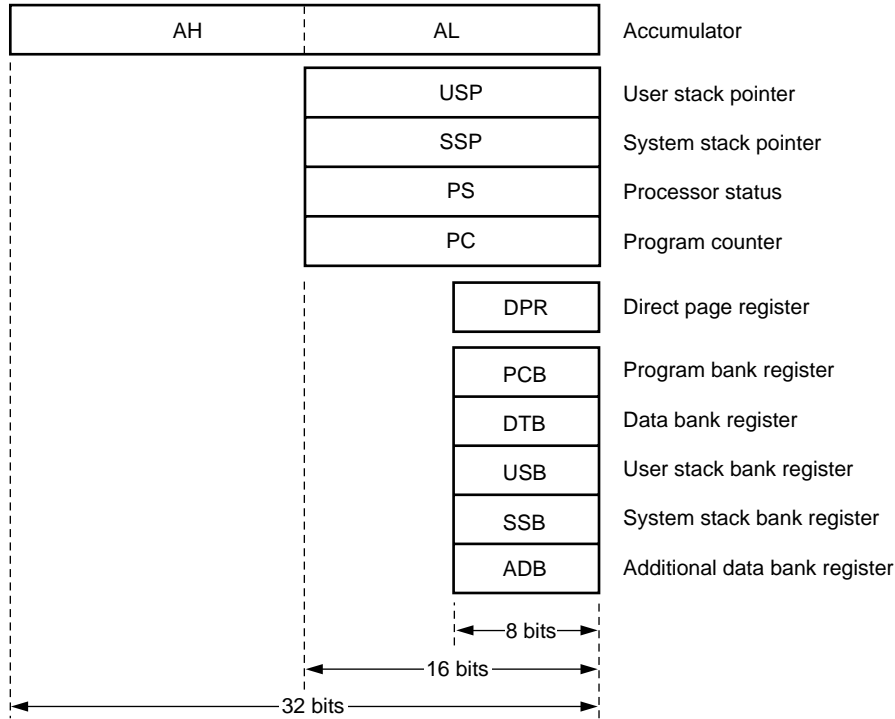

• General-purpose Registers

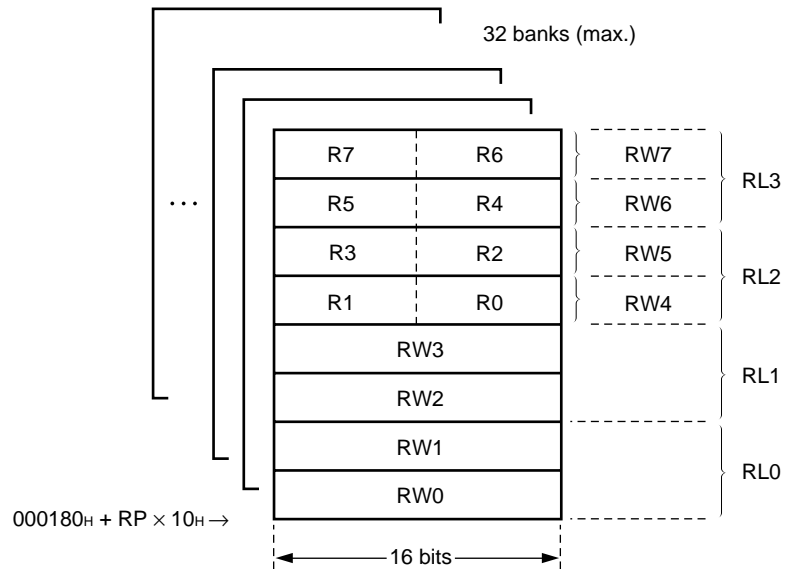

• Processor States (PS)

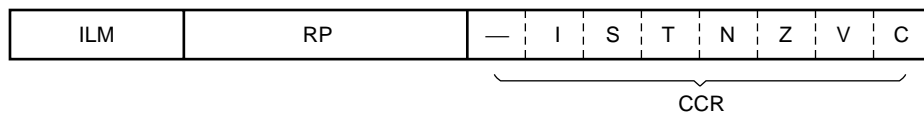

MEMORY MAP

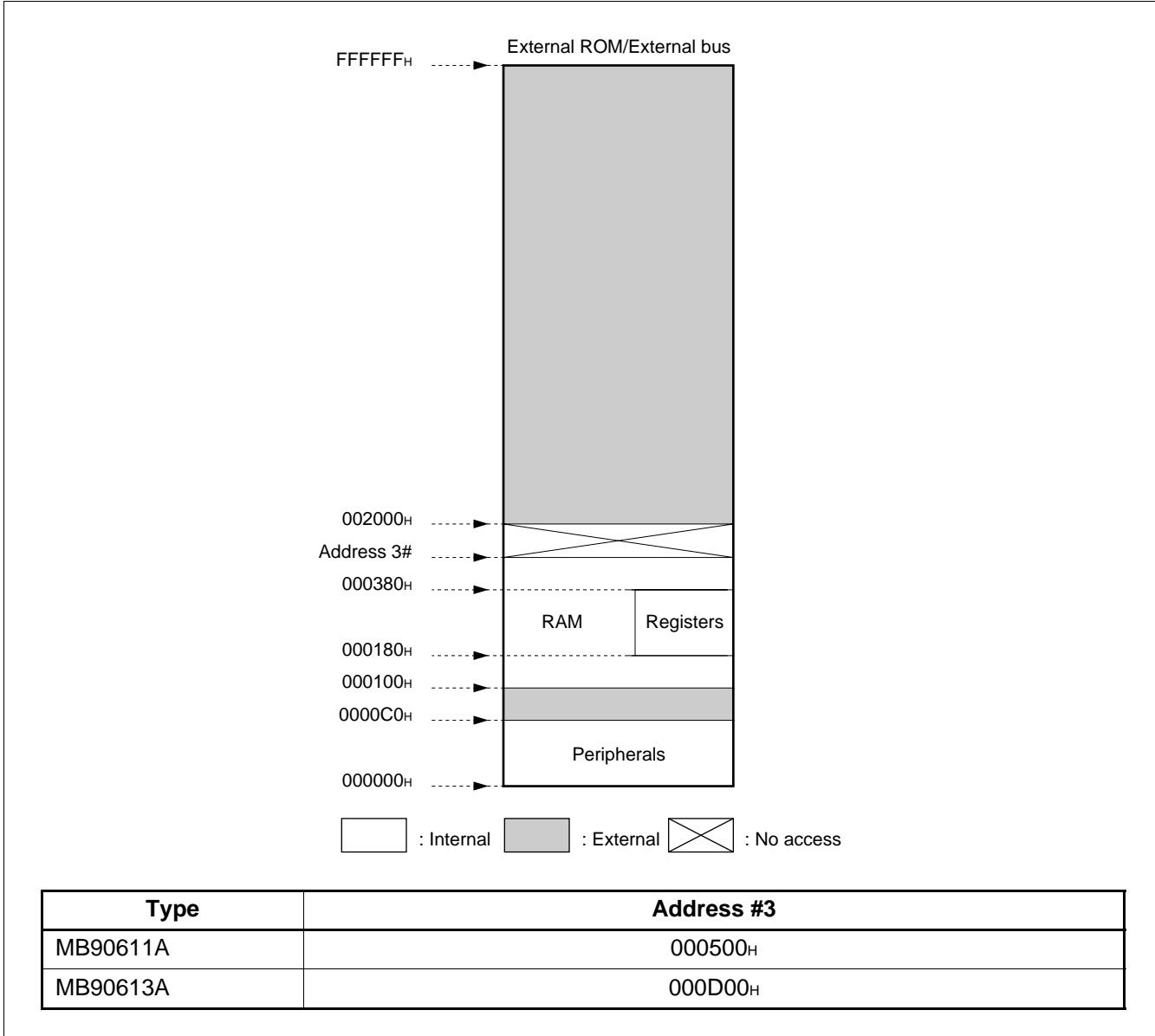

MB90610A Series

■ I/O MAP

Address	Register	Name	Access	Resource name	Initial value
000000H	Free	—	*3	—	—
000001H	Port 1 data register	PDR1	R/W*	Port 1 ⁸	XXXXXXXXXX
000002H	Port 2 data register	PDR2	R/W*	Port 2 ⁷	XXXXXXXXXX
000003H	Port 3 data register	PDR3	R/W*	Port 3 ⁷	XXXXXXXXXX
000004H	Port 4 data register	PDR4	R/W	Port 4	XXXXXXXXXX
000005H	Port 5 data register	PDR5	R/W	Port 5	--XXXXXXXX
000006H	Port 6 data register	PDR6	R/W	Port 6	11111111
000007H	Port 7 data register	PDR7	R/W	Port 7	-XXXXXXXXX
000008H	Port 8 data register	PDR8	R/W	Port 8	-XXXXXXXXX
000009H	Port 9 data register	PDR9	R/W	Port 9	--XXXXXXXX
00000AH	Port A data register	PDRA	R/W	Port A	XXXXXXXX-
00000BH to 10H	Vacancy	—	*3	—	—
000011H	Port 1 direction register	DDR1	R/W*	Port 1 ⁸	00000000
000012H	Port 2 direction register	DDR2	R/W*	Port 2 ⁷	00000000
000013H	Port 3 direction register	DDR3	R/W*	Port 3 ⁷	00000000
000014H	Port 4 direction register	DDR4	R/W	Port 4	00000000
000015H	Port 5 direction register	DDR5	R/W	Port 5	--000000
000016H	Analog input enable register	ADER	R/W	Port 6	11111111
000017H	Port 7 direction register	DDR7	R/W	Port 7	-0000000
000018H	Port 8 direction register	DDR8	R/W	Port 8	-0000000
000019H	Port 9 direction register	DDR9	R/W	Port 9	--000000
00001AH	Port A direction register	DDRA	R/W	Port A	0000000-
00001BH to 1FH	Vacancy	—	*3	—	—
000020H	Serial mode register 0	SMR0	R/W!	UART0 (SCI)	00000000
000021H	Serial control register 0	SCR0	R/W!		00000100
000022H	Serial input data register 0/ Serial output data register 0	SIDR0/ SODR0	R/W		XXXXXXXXXX
000023H	Serial status register 0	SSR0	R/W!		00001-00
000024H	Serial mode register 1	SMR1	R/W!	UART1 (SCI)	00000000
000025H	Serial control register 1	SCR1	R/W!		00000100
000026H	Serial input data register 1/ Serial output data register 1	SIDR1/ SODR1	R/W		XXXXXXXXXX
000027H	Serial status register 1	SSR1	R/W!		00001-00

(Continued)

MB90610A Series

Address	Register	Name	Access	Resource name	Initial value	
000028 _H	Interrupt/DTP enable register	ENIR	R/W	DTP/external interrupt	0 0 0 0 0 0 0 0	
000029 _H	Interrupt/DTP request register	EIRR	R/W		0 0 0 0 0 0 0 0	
00002A _H	Interrupt level setting register	ELVR	R/W		0 0 0 0 0 0 0 0	
00002B _H					0 0 0 0 0 0 0 0	
00002C _H	AD control status register	ADCS	R/W!	A/D converter	0 0 0 0 0 0 0 0	
00002D _H					0 0 0 0 0 0 0 0	
00002E _H	AD data register	ADCR	R/W! *4		XXXXXXXXXX	
00002F _H					0 0 0 0 0 0 XX	
000030 _H	PPG0 operation mode control register	PPGC0	R/W	PPG0	0 0 0 0 0 0 – 1	
000031 _H	PPG1 operation mode control register	PPGC1	R/W	PPG1	0 0 0 0 0 0 – 1	
000032 _H , 33 _H	Vacancy	—	*3	—	—	
000034 _H	PPG0 reload register	PRL0	R/W	PPG0	XXXXXXXXXX	
000035 _H					XXXXXXXXXX	
000036 _H	PPG1 reload register	PRL1	R/W	PPG1	XXXXXXXXXX	
000037 _H					XXXXXXXXXX	
000038 _H	Control status register	TMCSR0	R/W!	16-bit reload timer 0	0 0 0 0 0 0 0 0	
000039 _H					– – – – 0 0 0 0	
00003A _H					16-bit timer register/ 16-bit reload register	TMR0/ TMRLR0
00003B _H	XXXXXXXXXX					
00003C _H	Control status register	TMCSR1	R/W!		16-bit reload timer 1	0 0 0 0 0 0 0 0
00003D _H						– – – – 0 0 0 0
00003E _H	16-bit timer register/ 16-bit reload register	TMR1/ TMRLR1	R/W	XXXXXXXXXX		
00003F _H				XXXXXXXXXX		
000040 _H to 43 _H	Vacancy	—	*3	—		—
000044 _H	Serial mode register 2	SMR2	R/W!	UART2 (SCI)		0 0 0 0 0 0 0 0
000045 _H	Serial control register 2	SCR2	R/W!		0 0 0 0 0 1 0 0	
000046 _H	Serial input data register 2/ Serial output data register 2	SIDR2/ SODR2	R/W		XXXXXXXXXX	
000047 _H	Serial status register 2	SSR2	R/W!		0 0 0 0 1 – 0 0	
000048 _H	CS control register 0	CSCR0	R/W	Chip select function	– – – – 0 0 0 0	
000049 _H	CS control register 1	CSCR1	R/W		– – – – 0 0 0 0	
00004A _H	CS control register 2	CSCR2	R/W		– – – – 0 0 0 0	
00004B _H	CS control register 3	CSCR3	R/W		– – – – 0 0 0 0	

(Continued)

MB90610A Series

Address	Register	Name	Access ²	Resource name	Initial value
00004C _H	CS control register 4	CSCR4	R/W	Chip select function	----0000
00004D _H	CS control register 5	CSCR5	R/W		----0000
00004E _H	CS control register 6	CSCR6	R/W		----0000
00004F _H	CS control register 7	CSCR7	R/W		----0000
000050 _H	Vacancy	—	*3	—	—
000051 _H	UART0 (SCI) machine clock division control register	CDCR0	W	UART0 (SCI)	----1111
000052 _H	Vacancy	—	*3	—	—
000053 _H	UART1 (SCI) machine clock division control register	CDCR1	W	UART1 (SCI)	----1111
000054 _H	Vacancy	—	*3	—	—
000055 _H	UART2 (SCI) machine clock division control register	CDCR2	W	UART2 (SCI)	----1111
000056 _H to 8F _H	Vacancy	—	*3	—	—
000090 _H to 9E _H	Reserved system area	—	*1	—	—
00009F _H	Delayed interrupt generate/release register	DIRR	R/W	Delayed interrupt generation module	-----0
0000A0 _H	Low power consumption mode control register	LPMCR	R/W!	Low power consumption	00011000
0000A1 _H	Clock selection register	CKSCR	R/W!	Low power consumption	11111100
0000A2 _H to A4 _H	Vacancy	—	*3	—	—
0000A5 _H	Auto-ready function selection register	ARSR	W	External pins	0011--00
0000A6 _H	External address output control register	HACR	W	External pins	00000000
0000A7 _H	Bus control signal selection register	ECSR	W	External pins	-000*000
0000A8 _H	Watchdog timer control register	WDTC	R/W!	Watchdog timer	XXXXX111
0000A9 _H	Timebase timer control register	TBTC	R/W!	Timebase timer	1--00100
0000AA _H to AF _H	Vacancy	—	*3	—	—
0000B0 _H	Interrupt control register 00	ICR00	R/W!	Interrupt controller	00000111
0000B1 _H	Interrupt control register 01	ICR01	R/W!		00000111
0000B2 _H	Interrupt control register 02	ICR02	R/W!		00000111
0000B3 _H	Interrupt control register 03	ICR03	R/W!		00000111
0000B4 _H	Interrupt control register 04	ICR04	R/W!		00000111
0000B5 _H	Interrupt control register 05	ICR05	R/W!		00000111

(Continued)

(Continued)

Address	Register	Name	Access	Resource name	Initial value
0000B6 _H	Interrupt control register 06	ICR06	R/W!	Interrupt controller	0 0 0 0 0 1 1 1
0000B7 _H	Interrupt control register 07	ICR07	R/W!		0 0 0 0 0 1 1 1
0000B8 _H	Interrupt control register 08	ICR08	R/W!		0 0 0 0 0 1 1 1
0000B9 _H	Interrupt control register 09	ICR09	R/W!		0 0 0 0 0 1 1 1
0000BA _H	Interrupt control register 10	ICR10	R/W!		0 0 0 0 0 1 1 1
0000BB _H	Interrupt control register 11	ICR11	R/W!		0 0 0 0 0 1 1 1
0000BC _H	Interrupt control register 12	ICR12	R/W!		0 0 0 0 0 1 1 1
0000BD _H	Interrupt control register 13	ICR13	R/W!		0 0 0 0 0 1 1 1
0000BE _H	Interrupt control register 14	ICR14	R/W!		0 0 0 0 0 1 1 1
0000BF _H	Interrupt control register 15	ICR15	R/W!		0 0 0 0 0 1 1 1
0000C0 _H to FF _H	External area *2	—	—	—	—

Initial values

- 0 : The initial value for this bit is “0”.
- 1 : The initial value for this bit is “1”.
- * : The initial value for this bit is “1” or “0”. (Determined by the level of the MD0 to MD2 pins.)
- X : The initial value for this bit is undefined.
- : This bit is not used. The initial value is undefined.

*1: Access prohibited.

*2: This is the only external access area in the area below address 0000FF_H. Access this address as an external I/O area.

*3: Areas marked as “free” in the I/O map are reserved areas. These areas are accessed by internal access. No access signals are output on the external bus.

*4: Only bit 15 can be written. The other bits are written to by the test function. Reading bits 10 to 15 returns zeros.

*5: The R/W! symbol in the Read/Write column indicates that some bits are read-only or write-only. See the resource’s register list for details.

6: Using a read-modify-write instruction (such as the bit set instruction) to access one of the registers indicated by R/W!, R/W, or W in the Read/Write column sets the specified bit to the desired value. However, this can cause misoperation if the other register bits include write-only bits. Therefore, do not use read-modify-write instructions to access these registers.

*7: This register is only available when the address/data bus is in multiplex mode. Access to the register is prohibited in non-multiplex mode.

*8: This register is only available when the external data bus is in 8-bit mode. Access to the register is prohibited in 16-bit mode.

Note: The initial values listed for write-only bits are the initial values set by a reset. They are not the values returned by a read.

Also, LPMCR/CKSCR/WDTA are sometimes initialized and sometimes not initialized, depending on the reset type. The listed initial values are for when these registers are initialized.

MB90610A Series

■ INTERRUPT VECTOR AND INTERRUPT CONTROL REGISTER ASSIGNMENTS TO INTERRUPT SOURCES

Interrupt source	I ² OS support	Interrupt vector			Interrupt control register	
		Number	Address	Address	ICR	Address
Reset	×	#08	08 _H	FFFFDC _H	—	—
INT 9 instruction	×	#09	09 _H	FFFFD8 _H	—	—
Exception	×	#10	0A _H	FFFFD4 _H	—	—
External interrupt #0	○	#11	0B _H	FFFFD0 _H	ICR00	0000B0 _H
External interrupt #1	○	#13	0D _H	FFFFC8 _H	ICR01	0000B1 _H
External interrupt #2	○	#15	0F _H	FFFFC0 _H	ICR02	0000B2 _H
External interrupt #3	○	#17	11 _H	FFFFB8 _H	ICR03	0000B3 _H
External interrupt #4	○	#19	13 _H	FFFFB0 _H	ICR04	0000B4 _H
External interrupt #5	○	#21	15 _H	FFFFA8 _H	ICR05	0000B5 _H
External interrupt #6	○	#23	17 _H	FFFFA0 _H	ICR06	0000B6 _H
UART0 • transmit complete	○	#24	18 _H	FFFF9C _H		
External interrupt #7	○	#25	19 _H	FFFF98 _H	ICR07	0000B7 _H
UART1 • transmit complete	○	#26	1A _H	FFFF94 _H		
PPG #0	×	#27	1B _H	FFFF90 _H	ICR08	0000B8 _H
PPG #1	×	#28	1C _H	FFFF8C _H		
16-bit reload timer #0	○	#29	1D _H	FFFF88 _H	ICR09	0000B9 _H
16-bit reload timer #1	○	#30	1E _H	FFFF84 _H		
A/DC measurement complete	○	#31	1F _H	FFFF80 _H	ICR10	0000BA _H
UART2 • transmit complete	○	#33	21 _H	FFFF78 _H	ICR11	0000BB _H
Timebase timer interval interrupt	×	#34	22 _H	FFFF74 _H		
UART2 • receive complete	⊙	#35	23 _H	FFFF70 _H	ICR12	0000BC _H
UART1 • receive complete	⊙	#37	25 _H	FFFF68 _H	ICR13	0000BD _H
UART0 • receive complete	⊙	#39	27 _H	FFFF60 _H	ICR14	0000BE _H
Delayed interrupt generation module	×	#42	2A _H	FFFF54 _H	ICR15	0000BF _H

- : indicates that the interrupt request flag is cleared by the I²OS interrupt clear signal (no stop request).
- ⊙ : indicates that the interrupt request flag is cleared by the I²OS interrupt clear signal (with stop request).
- ×

Note: Do not specify I²OS activation in interrupt control registers that do not support I²OS.

■ PERIPHERAL RESOURCES

1. Parallel Port

The MB90610A series has 58 I/O pins, 18 output pins, and 8 open drain output pins.

Ports 1 to 5 and ports 7 to A are I/O ports. The ports are inputs when the corresponding direction register bit is "0" and outputs when the corresponding bit is "1".

Port 1 is only available when the external data bus is in 8-bit mode. Access is prohibited in 16-bit mode.

Ports 2 and 3 are only available when the address/data bus is in multiplex mode. Access is prohibited in non-multiplex mode.

Port 6 is an open drain port. Port 6 pins can only be used as ports when the analog input enable register is "0".

(1) Register Configuration

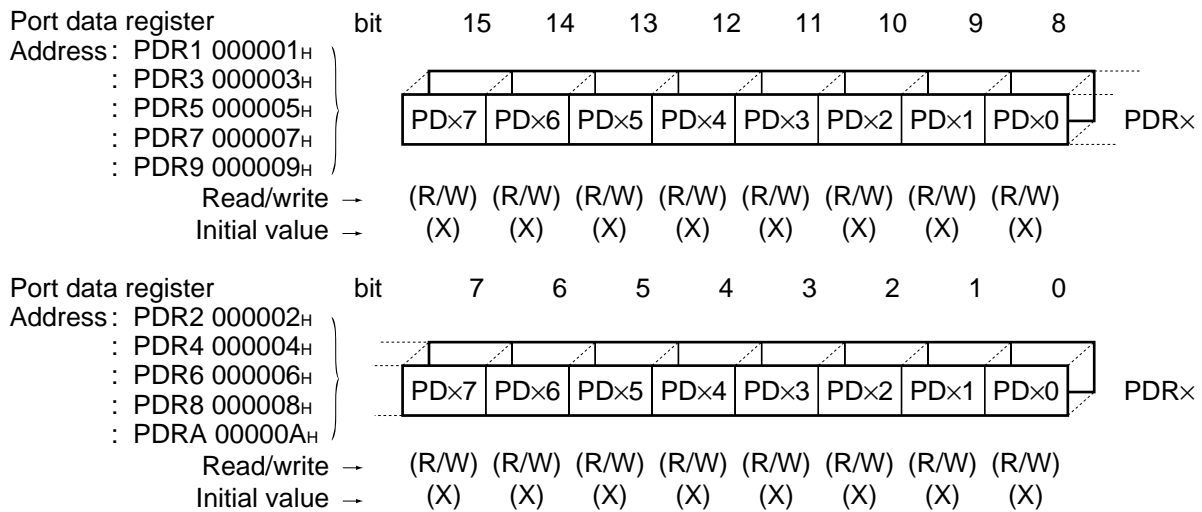

Notes: No register bits are provided for bit 6 to 7 of port 5.

No register bit is provided for bit 7 of port 7.

No register bit is provided for bit 7 of port 8.

No register bits are provided for bits 6 to 7 of port 9.

No register bit is provided for bit 0 of port A.

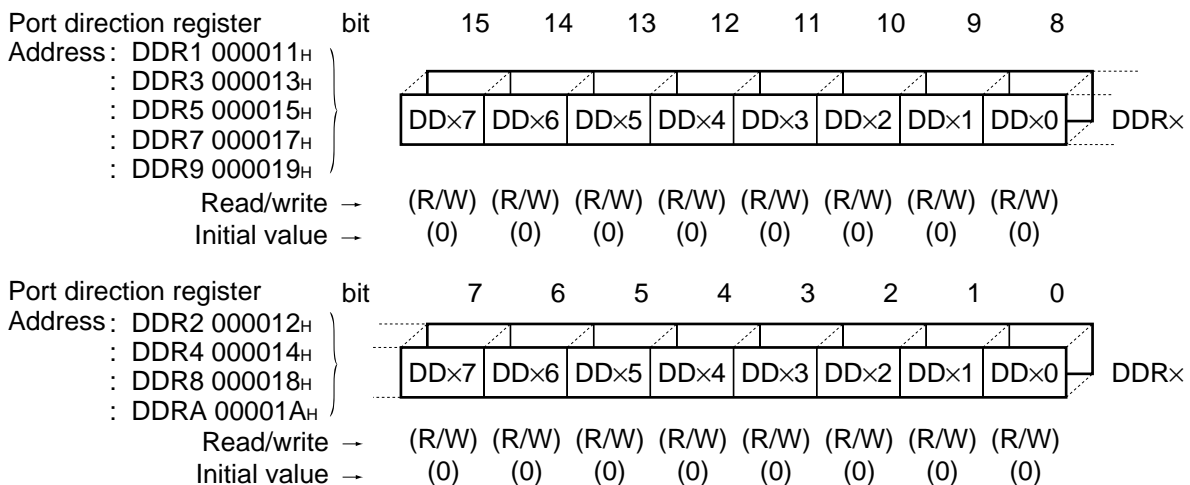

MB90610A Series

Note: No register bits are provided for bit 6 to 7 of port 5.
 No register bit is provided for bit 7 of port 7.
 No register bit is provided for bit 7 of port 8.
 No register bits are provided for bits 6 to 7 of port 9.
 No register bit is provided for bit 0 of port A.
 Port 6 does not have a DDR.

bit	15	14	13	12	11	10	9	8	
Analog input enable register ADER 000016H	ADE7	ADE6	ADE5	ADE4	ADE3	ADE2	ADE1	ADE0	ADER
Read/write →	(R/W)	(R/W)	(R/W)	(R/W)	(R/W)	(R/W)	(R/W)	(R/W)	
Initial value →	(1)	(1)	(1)	(1)	(1)	(1)	(1)	(1)	

(2) Register Details

• Port Data Registers

bit	15	14	13	12	11	10	9	8	
Port data register Address: PDR1 000001H : PDR3 000003H : PDR5 000005H : PDR7 000007H : PDR9 000009H	PD×7	PD×6	PD×5	PD×4	PD×3	PD×2	PD×1	PD×0	PDR×
Read/write →	(R/W)	(R/W)	(R/W)	(R/W)	(R/W)	(R/W)	(R/W)	(R/W)	
Initial value →	(X)	(X)	(X)	(X)	(X)	(X)	(X)	(X)	

bit	7	6	5	4	3	2	1	0	
Port data register Address: PDR2 000002H : PDR4 000004H : PDR6 000006H : PDR8 000008H : PDRA 00000AH	PD×7	PD×6	PD×5	PD×4	PD×3	PD×2	PD×1	PD×0	PDR×
Read/write →	(R/W)	(R/W)	(R/W)	(R/W)	(R/W)	(R/W)	(R/W)	(R/W)	
Initial value →	(X)	(X)	(X)	(X)	(X)	(X)	(X)	(X)	

Note: No register bits are provided for bit 6 to 7 of port 5.
 No register bit is provided for bit 7 of port 7.
 No register bit is provided for bit 7 of port 8.
 No register bits are provided for bits 6 to 7 of port 9.
 No register bit is provided for bit 0 of port A.
 Port 1 is only available when the external data bus is in 8-bit mode. Access is prohibited in 16-bit mode.
 Ports 2, 3 are only available in multiplex mode. Access is prohibited in non-multiplex mode.

• Port Direction Registers

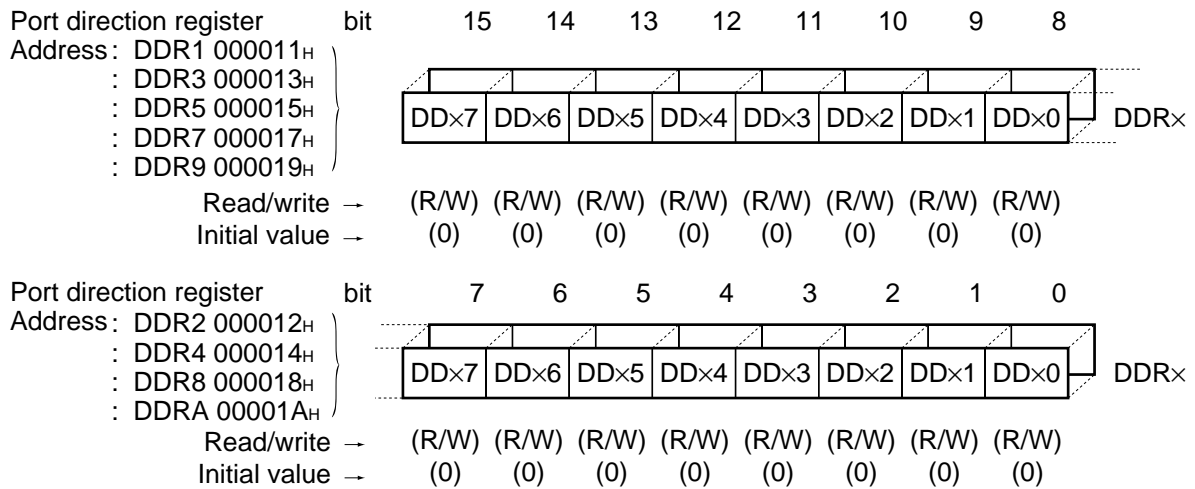

When pins are used as ports, the register bits control the corresponding pins as follows.

- 0: Input mode
- 1: Output mode

Bits are set to “0” by a reset.

Note: No register bits are provided for bit 6 to 7 of port 5.

No register bit is provided for bit 7 of port 7.

No register bit is provided for bit 7 of port 8.

No register bit is provided for bit 0 of port A.

No register bits are provided for bits 6 to 7 of port 9.

Port 6 does not have a DDR.

Port 1 is only available when the external data bus is in 8-bit mode. Access is prohibited in 16-bit mode.

Ports 2 and 3 are only available in multiplex mode. Access is prohibited in non-multiplex mode.

• Analog Input Enable Register

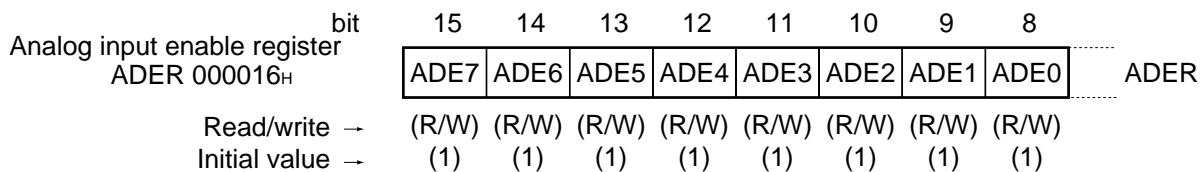

Controls each pin of port 6 as follows.

- 0: Port input mode
- 1: Analog input mode

Bits are set to “1” by a reset.

Note: Inputting an intermediate level signal in port input mode causes an input leak current to flow. Therefore, set to analog input mode when applying an analog input.

MB90610A Series

(3) Block Diagrams

• I/O Port

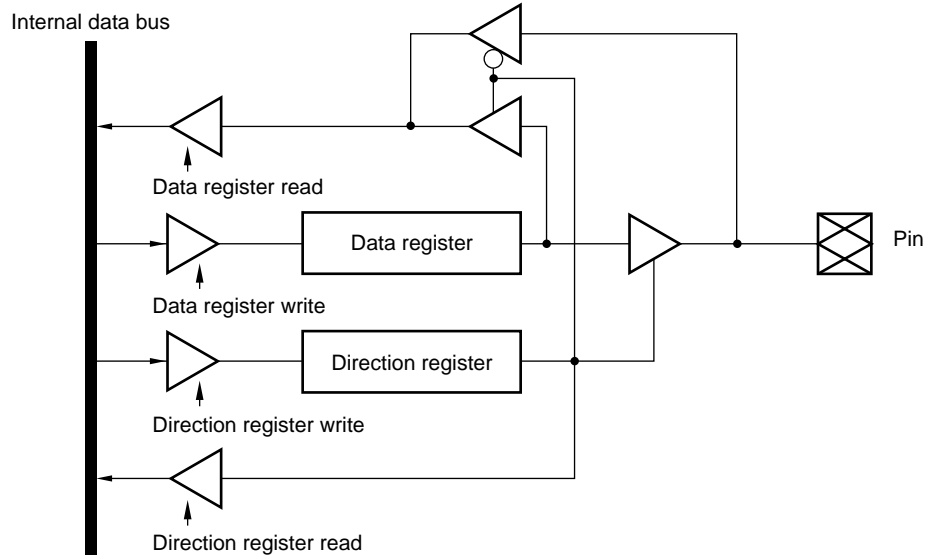

• Open Drain Port (Also used as Analog Inputs)

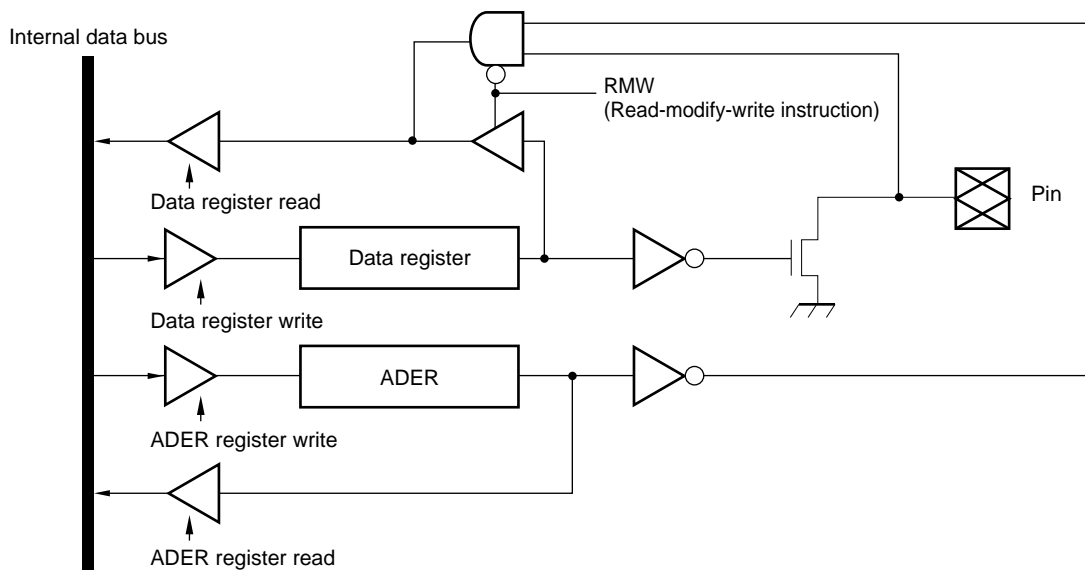

MB90610A Series

(4) Port Pin Allocation

Ports 1, 2, 3, 4, and 5 on the MB90610A series share pins with the external bus. The pin functions are determined by the bus mode and register settings.

Pin	Function							
	Non-multiplex mode				Multiplex mode			
	External address control				External address control			
	Enable (address)		Disable (port)		Enable (address)		Disable (port)	
	External bus width		External bus width		External bus width		External bus width	
	8-bit	16-bit	8-bit	16-bit	8-bit	16-bit	8-bit	16-bit
D07 to D00 AD07 to AD00	D07 to D00				AD07 to AD00			
P17 to P10/ D15 to D08/ AD15 to AD08	Port	D15 to D08	Port	D15 to D08	A15 to A08	AD15 to AD08	A15 to A08	AD15 to AD08
P27 to P20/ A07 to A00	A07 to A00		A07 to A00		Port			
P37 to P30/ A15 to A08	A15 to A08		A15 to A08					
P47 to P40/ A23 to A16	A23 to A16		Port		A23 to A16		Port	
P57/ALE	ALE				ALE			
\overline{RD}	\overline{RD}				\overline{RD}			
P55/ \overline{WRL}	\overline{WRL}				\overline{WRL}			
P54/ \overline{WRH}	Port	\overline{WRH}	Port	\overline{WRH}	Port	\overline{WRH}	Port	\overline{WRH}
P53/HRQ	HRQ				HRQ			
P52/ \overline{HAK}	\overline{HAK}				\overline{HAK}			
P51/RDY	RDY				RDY			
P50/CLK	CLK				CLK			

Note: The upper address, \overline{WRL} , \overline{WRH} , \overline{HAK} , HRQ, RDY, and CLK can be set for use as ports by function selection.

MB90610A Series

2. UART 0/1/2 (SCI)

UART 0/1/2 are serial I/O ports that can be used for CLK asynchronous (start-stop synchronization) or CLK synchronous (I/O expansion serial) data transfer. The ports have the following features.

- Full duplex, double buffered
- Supports CLK asynchronous (start-stop synchronization) and CLK synchronous (I/O expansion serial) data transfer
- Multi-processor mode support
- Built-in dedicated baud rate generator
 CLK asynchronous: 62500/31250/19230/9615/4808/2404/1202 bps
 CLK synchronous: 2 M/1 M/500 K/250 K bps
- Supports flexible baud rate setting using an external clock
- Error detect function (parity, framing, and overrun)
- NRZ type transmission signal
- Intelligent I/O service support

(1) Register Configuration

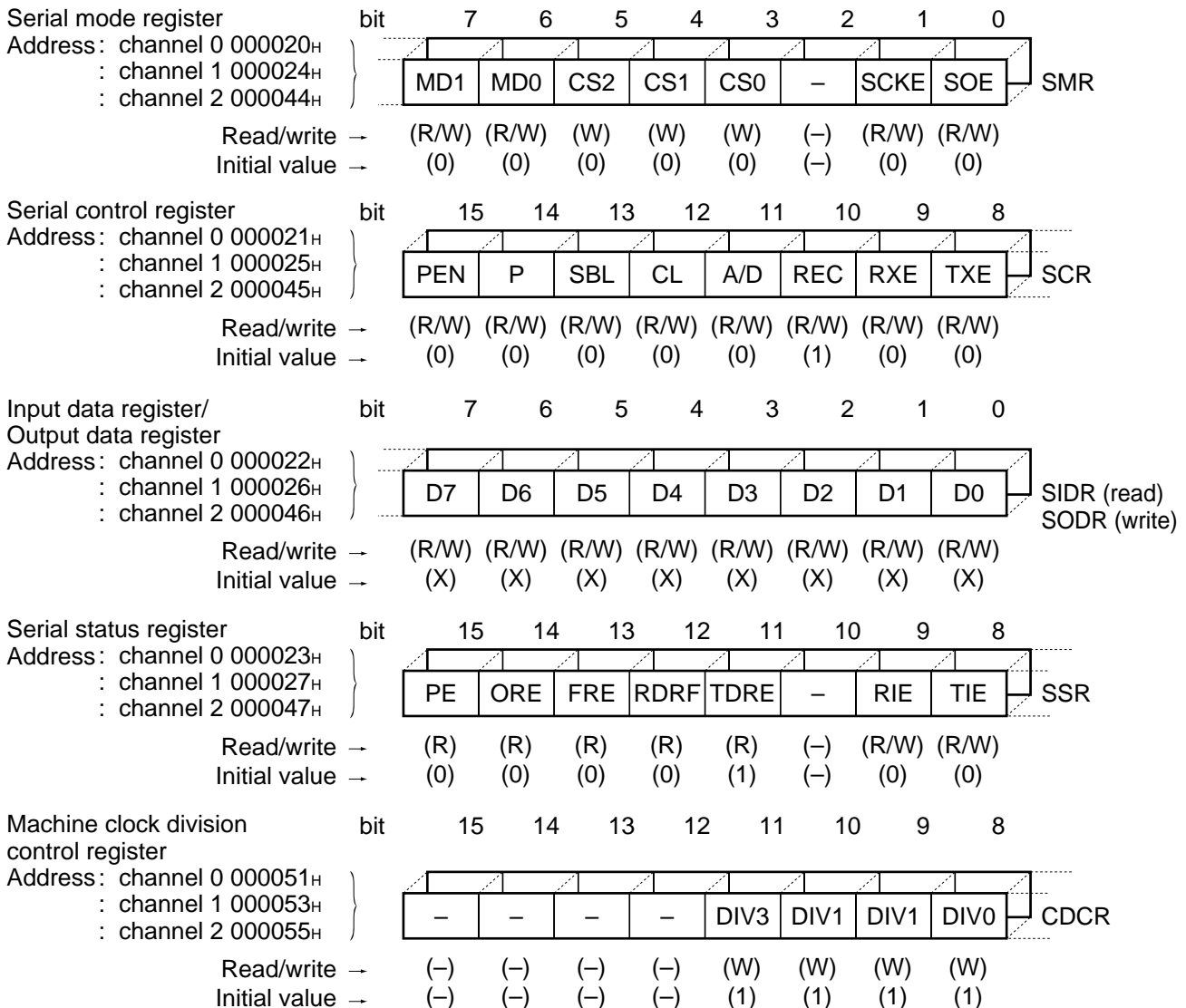

(2) Block Diagram

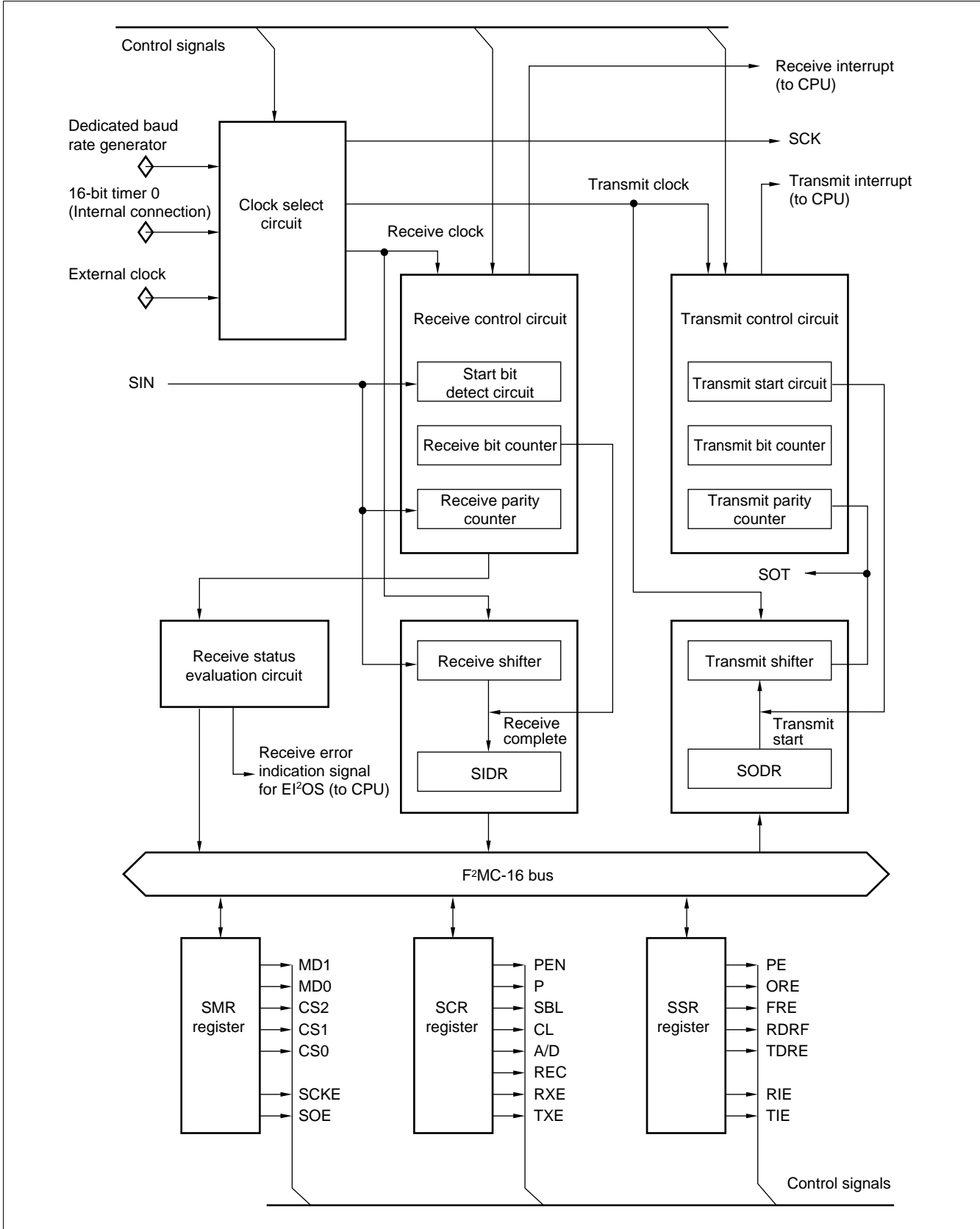

MB90610A Series

3. 10-bit 8-input A/D Converter (With 8-bit Resolution Mode)

The 10-bit 8-input A/D converter converts analog input voltages to digital values. The A/D converter has the following features.

- Conversion time: Minimum of 6.13 μ s per channel (98 machine cycles/16 MHz machine clock. This includes the sample and hold time)
- Sample and hold time: Minimum of 3.75 μ s per channel (60 machine cycles/16 MHz machine clock)
- Uses RC-type successive approximation conversion with a sample and hold circuit.
- 10-bit or 8-bit resolution
- Eight program-selectable analog input channels
 - Single conversion mode : Selectively convert a one channel.
 - Scan conversion mode : Continuously convert multiple channels. Maximum of 8 program-selectable channels.
 - Continuous conversion mode : Repeatedly convert specified channels.
 - Stop conversion mode : Convert one channel then halt until the next activation. (Enables synchronization of the conversion start timing.)
- An A/D conversion completion interrupt request to the CPU can be generated on the completion of A/D conversion. This interrupt can activate I²OS to transfer the result of A/D conversion to memory and is suitable for continuous operation.
- Activation by software, external trigger (falling edge), or timer (rising edge) can be selected.

(1) Register Configuration

		bit	15	14	13	12	11	10	9	8	
A/D control status register (upper)											
Address: 00002D _H			BUSY	INT	INTE	PAUS	STS1	STS0	STRT	Reserved	ADCS1
Read/write	→		(R/W)	(R/W)	(R/W)	(R/W)	(R/W)	(R/W)	(W)	(-)	
Initial value	→		(0)	(0)	(0)	(0)	(0)	(0)	(0)	(0)	
		bit	7	6	5	4	3	2	1	0	
A/D control status register (lower)											
Address: 00002C _H			MD1	MD0	ANS2	ANS1	ANS0	ANE2	ANE1	ANE0	ADCS0
Read/write	→		(R/W)	(R/W)	(R/W)	(R/W)	(R/W)	(R/W)	(R/W)	(R/W)	
Initial value	→		(0)	(0)	(0)	(0)	(0)	(0)	(0)	(0)	
		bit	15	14	13	12	11	10	9	8	
A/D data register (upper)											
Address: 00002E _H			S10	-	-	-	-	-	D9	D8	ADCR1
Read/write	→		(R/W)	(R)	(R)	(R)	(R)	(R)	(R)	(R)	
Initial value	→		(0)	(0)	(0)	(0)	(0)	(0)	(X)	(X)	
		bit	7	6	5	4	3	2	1	0	
A/D data register (lower)											
Address: 00002F _H			D7	D6	D5	D4	D3	D2	D1	D0	ADCR0
Read/write	→		(R)	(R)	(R)	(R)	(R)	(R)	(R)	(R)	
Initial value	→		(X)	(X)	(X)	(X)	(X)	(X)	(X)	(X)	

(2) Block Diagram

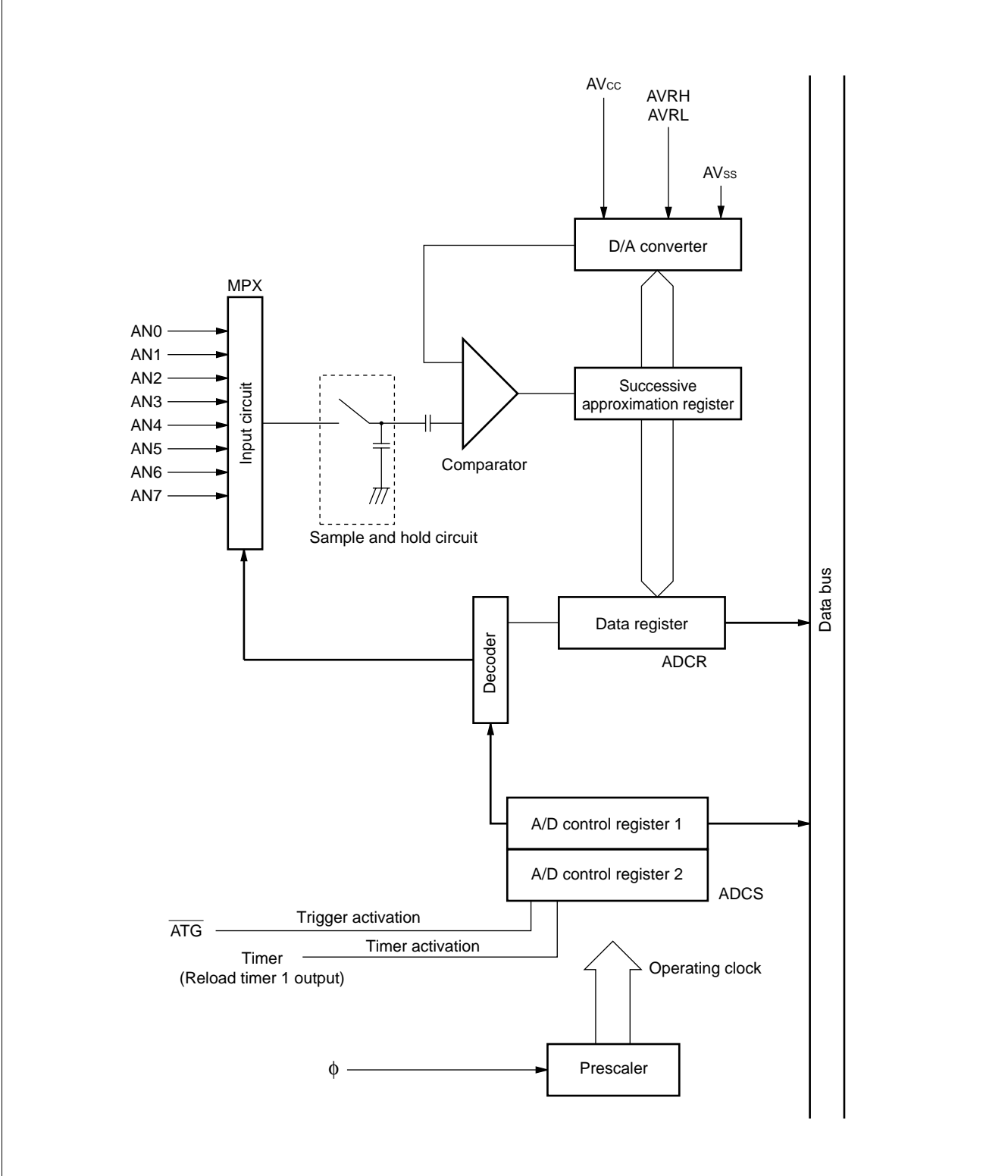

MB90610A Series

4. 8/16-bit PPG

This block contains the 8-bit reload timer module. The block performs PPG output in which the pulse output is controlled by the operation of the timer.

The hardware consists of two 8-bit down-counters, four 8-bit reload registers, one 16-bit control register, two external pulse output pins, and two interrupt outputs. The PPG has the following functions.

- 8-bit PPG output in 2-channel independent operation mode: Two independent PPG output channels are available.
- 16-bit PPG output operation mode : One 16-bit PPG output channel is available.
- 8+8-bit PPG output operation mode : Variable-period 8-bit PPG output operation is available by using the output of channel 0 as the clock input to channel 1.
- PPG output operation: Outputs pulse waveforms with variable period and duty ratio.
Can be used as a D/A converter in conjunction with an external circuit.

(1) Register Configuration

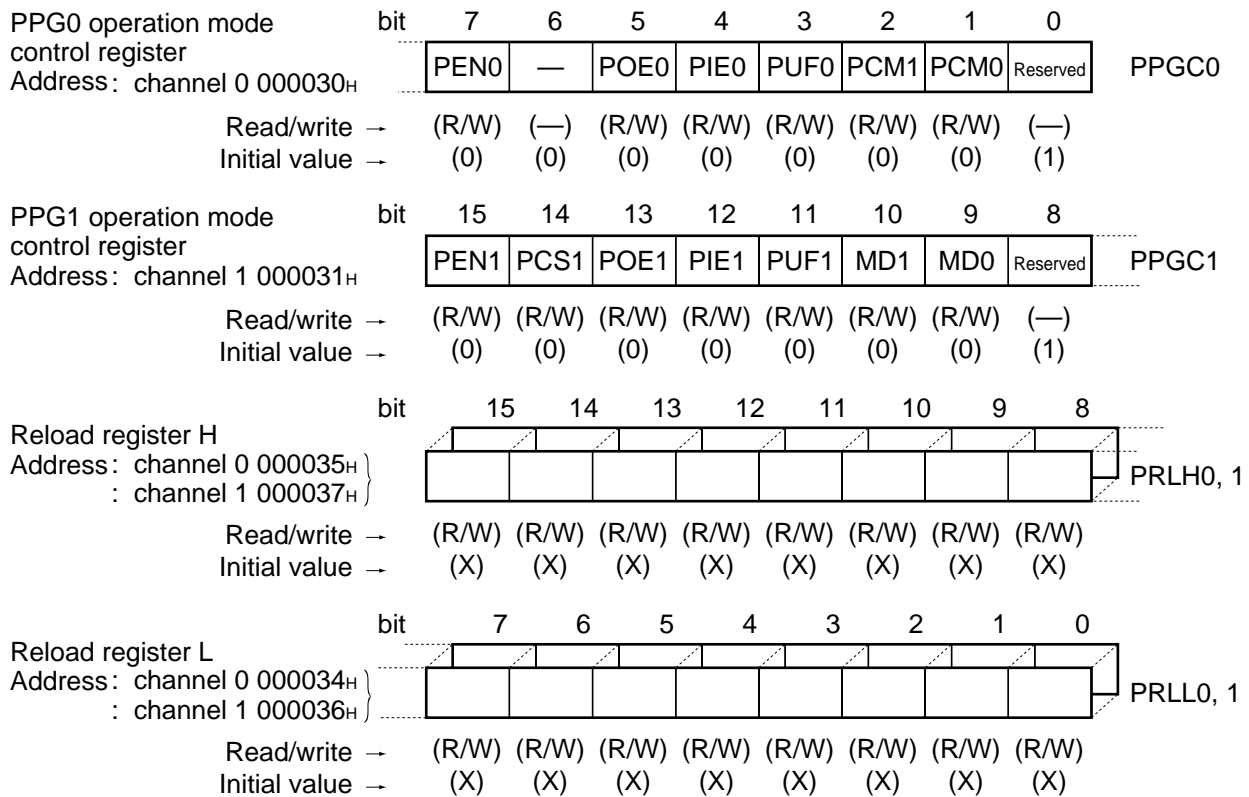

(2) Block Diagram

• 8/16-bit PPG (channel 0)

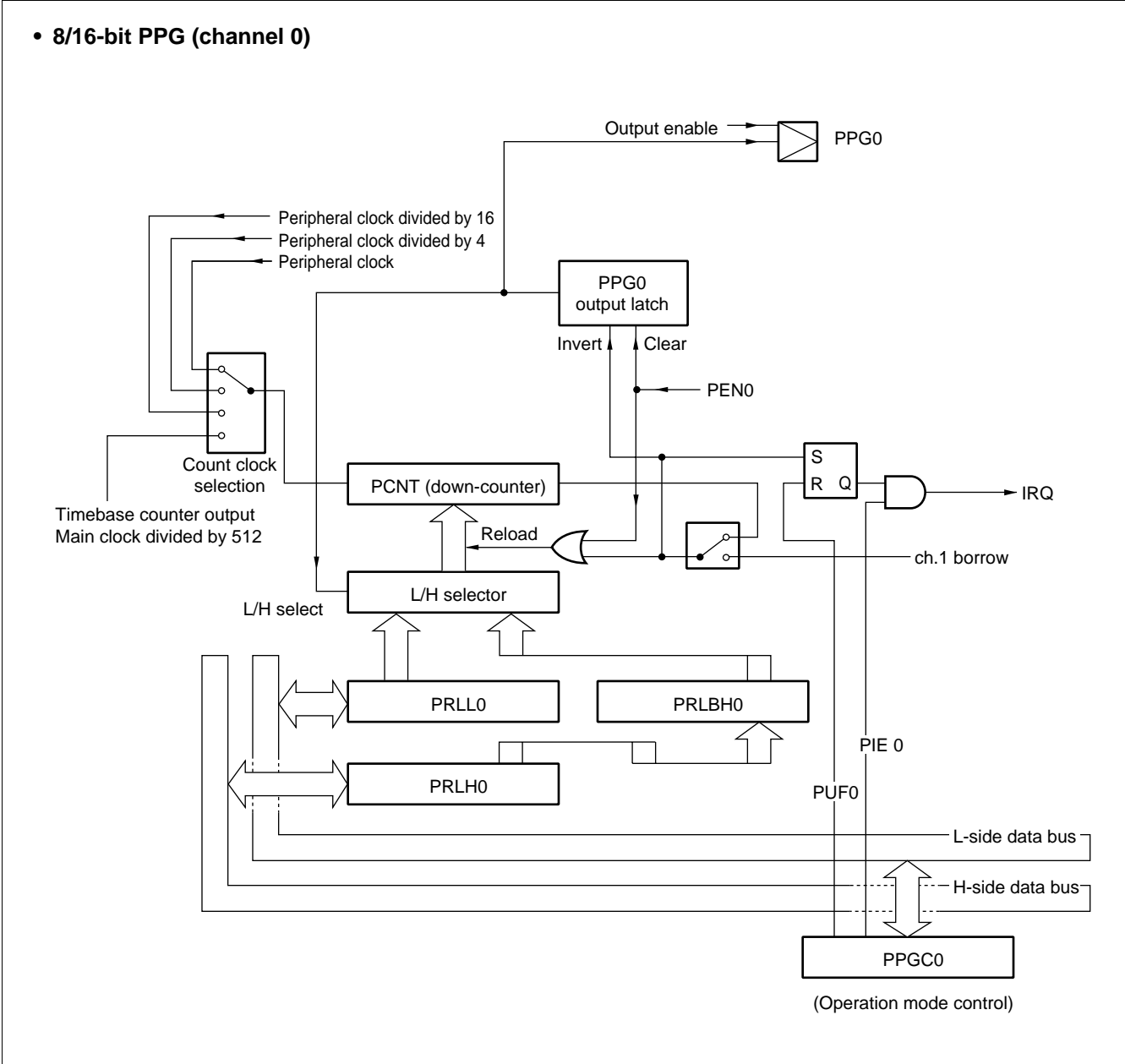

MB90610A Series

• 8/16-bit PPG (channel 1)

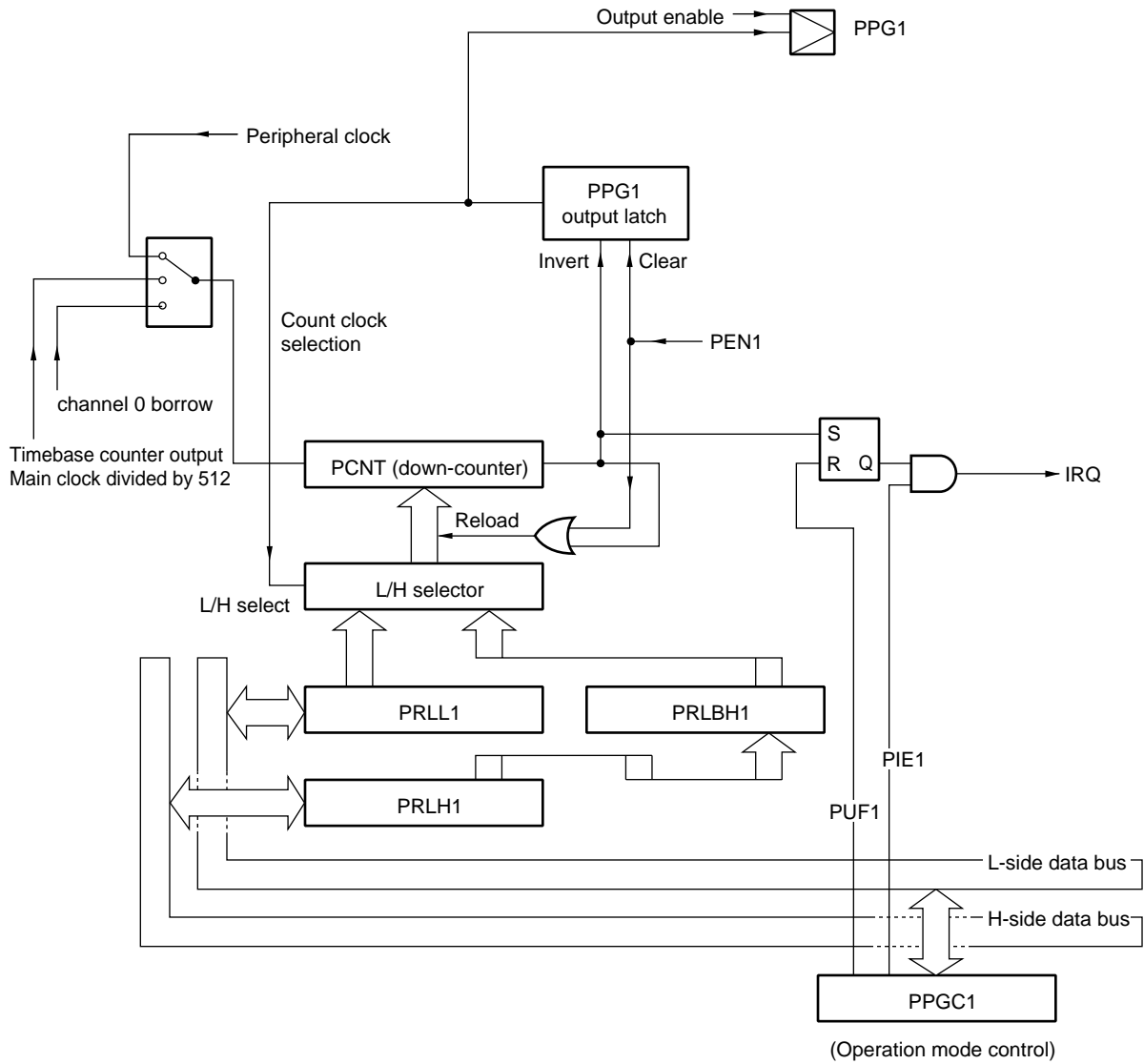

5. 16-bit Reload Timer (with Event Count Function)

The 16-bit reload timers consists of a 16-bit down-counter, a 16-bit reload register, one input (TIN) and one output (TOT) pin, and a control register. The input clock can be selected from one external clock and three types of internal clock. The output pin (TOT) outputs a toggle waveform in reload mode and a rectangular waveform during counting in one-shot mode. The input pin (TIN) functions as the event input in event count mode and as the trigger input or gate input in internal clock mode.

This product has two internal 16-bit reload timer channels.

(1) Register Configuration

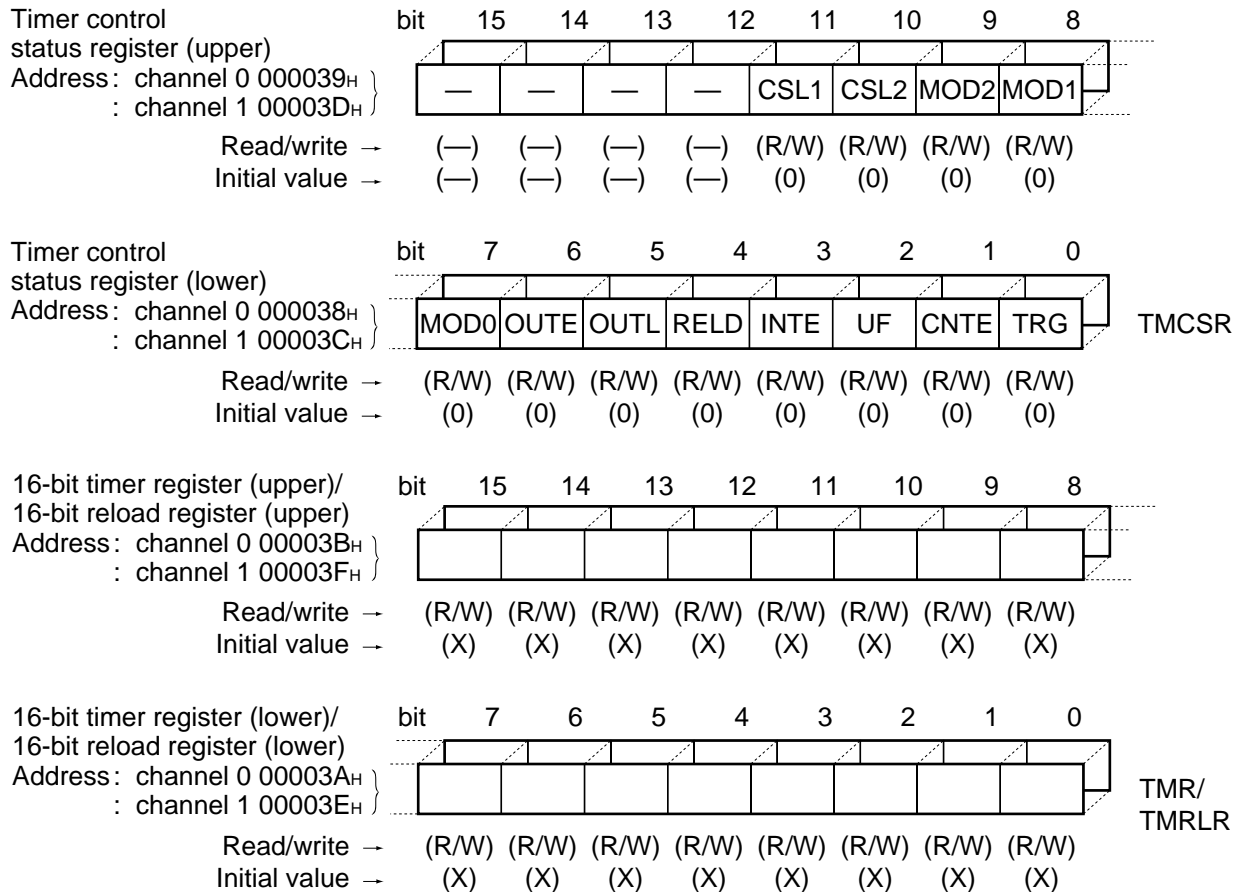

MB90610A Series

(2) Block Diagram

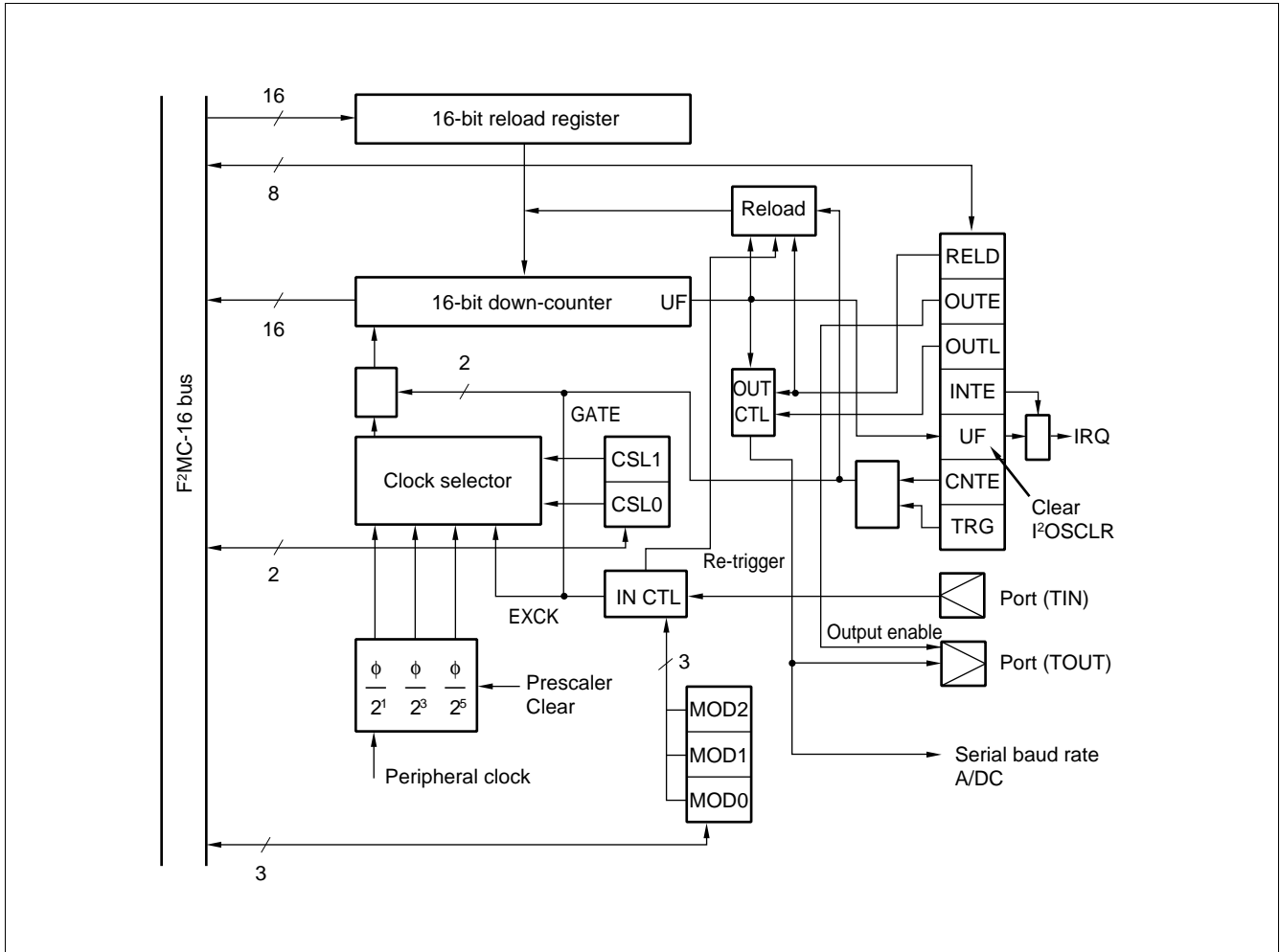

6. Chip Select Function

This module generates chip select signals to simplify connection of memory or I/O devices. The module has 8 chip select output pins. The hardware outputs the chip select signals from the pins when it detects access of an address in the areas specified in the pin registers.

(1) Register Configuration

Address: 000049 _H : 00004B _H : 00004D _H : 00004F _H	bit 15 14 13 12 11 10 9 8	<table border="1" style="width: 100%; border-collapse: collapse;"> <tr> <td style="width: 25px; height: 20px;">—</td> <td style="width: 25px; height: 20px;">—</td> <td style="width: 25px; height: 20px;">—</td> <td style="width: 25px; height: 20px;">—</td> <td style="width: 25px; height: 20px;">ACTL</td> <td style="width: 25px; height: 20px;">OPEL</td> <td style="width: 25px; height: 20px;">CSA1</td> <td style="width: 25px; height: 20px;">CSA0</td> </tr> </table>	—	—	—	—	ACTL	OPEL	CSA1	CSA0	Chip select control register (odd numbers: CSCR1/3/5/7)
—	—	—	—	ACTL	OPEL	CSA1	CSA0				

Address: 000048 _H : 00004A _H : 00004C _H : 00004E _H	bit 7 6 5 4 3 2 1 0	<table border="1" style="width: 100%; border-collapse: collapse;"> <tr> <td style="width: 25px; height: 20px;">—</td> <td style="width: 25px; height: 20px;">—</td> <td style="width: 25px; height: 20px;">—</td> <td style="width: 25px; height: 20px;">—</td> <td style="width: 25px; height: 20px;">ACTL</td> <td style="width: 25px; height: 20px;">OPEL</td> <td style="width: 25px; height: 20px;">CSA1</td> <td style="width: 25px; height: 20px;">CSA0</td> </tr> </table>	—	—	—	—	ACTL	OPEL	CSA1	CSA0	Chip select control register (even numbers: CSCR0/2/4/6)
—	—	—	—	ACTL	OPEL	CSA1	CSA0				

(2) Block Diagram

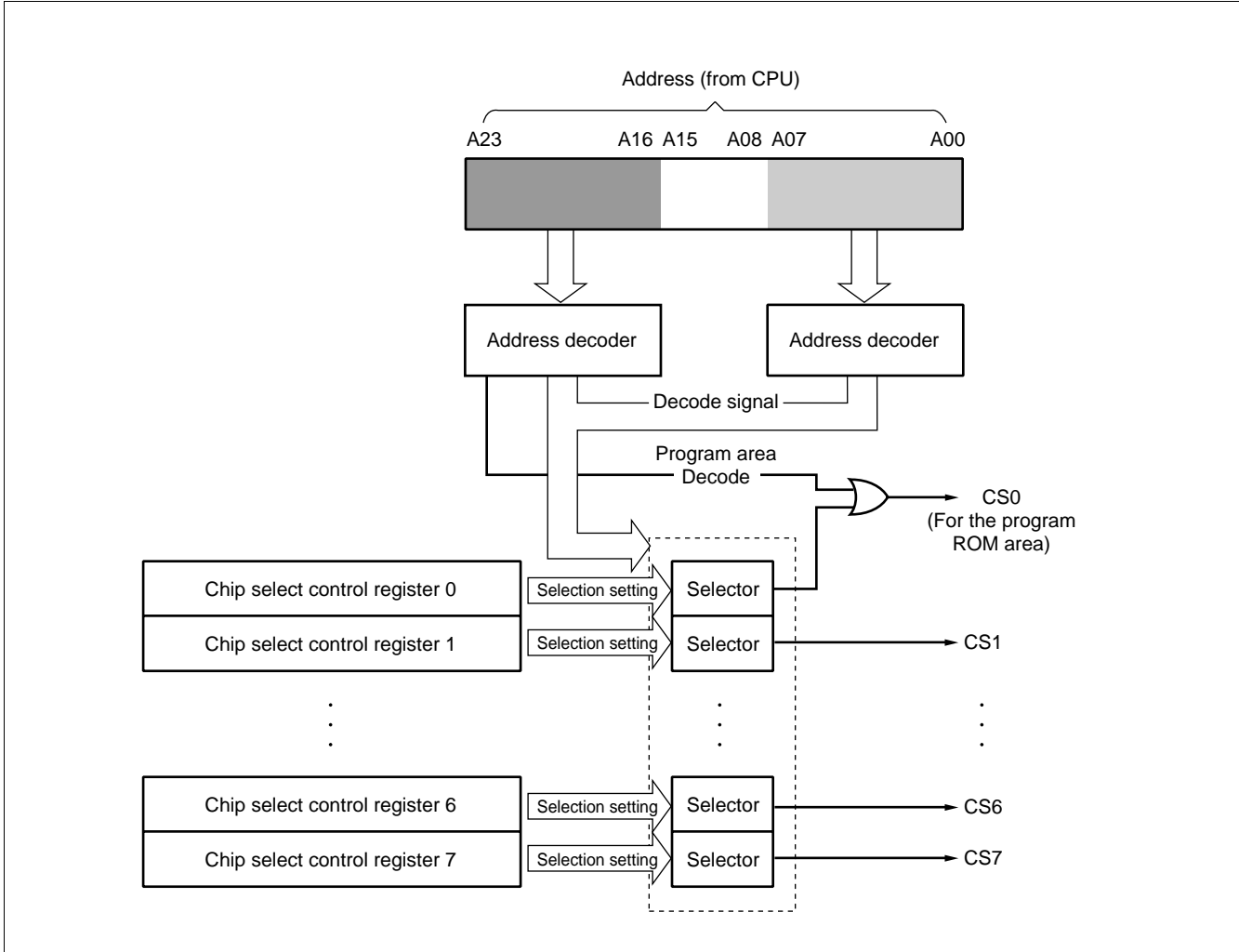

MB90610A Series

7. DTP/External Interrupts

The DTP (Data Transfer Peripheral) is a peripheral block that interfaces external peripherals to the F²MC-16L CPU. The DTP receives DMA and interrupt processing requests from external peripherals and passes the requests to the F²MC-16L CPU to activate the extended intelligent I/O service or interrupt processing. Two request levels (“H” and “L”) are provided for extended intelligent I/O service. For external interrupt requests, generation of interrupts on a rising or falling edge as well as on “H”, “L” levels can be selected, giving a total of four types.

(1) Register Configuration

Interrupt/DTP enable register Address: 000028 _H	bit 7	6	5	4	3	2	1	0	
	EN7	EN6	EN5	EN4	EN3	EN2	EN1	EN0	ENIR
Read/write →	(R/W)	(R/W)	(R/W)	(R/W)	(R/W)	(R/W)	(R/W)	(R/W)	
Initial value →	(0)	(0)	(0)	(0)	(0)	(0)	(0)	(0)	
Interrupt/DTP register Address: 000029 _H	bit 15	14	13	12	11	10	9	8	
	ER7	ER6	ER5	ER4	ER3	ER2	ER1	ER0	EIRR
Read/write →	(R/W)	(R/W)	(R/W)	(R/W)	(R/W)	(R/W)	(R/W)	(R/W)	
Initial value →	(0)	(0)	(0)	(0)	(0)	(0)	(0)	(0)	
Request level setting register (upper) Address: 00002B _H	bit 15	14	13	12	11	10	9	8	
	LB7	LA7	LB6	LA6	LB5	LA5	LB4	LA4	
Read/write →	(R/W)	(R/W)	(R/W)	(R/W)	(R/W)	(R/W)	(R/W)	(R/W)	
Initial value →	(0)	(0)	(0)	(0)	(0)	(0)	(0)	(0)	
Request level setting register (lower) Address: 00002A _H	bit 7	6	5	4	3	2	1	0	
	LB3	LA3	LB2	LA2	LB1	LA1	LB0	LA0	ELVR
Read/write →	(R/W)	(R/W)	(R/W)	(R/W)	(R/W)	(R/W)	(R/W)	(R/W)	
Initial value →	(0)	(0)	(0)	(0)	(0)	(0)	(0)	(0)	

(2) Block Diagram

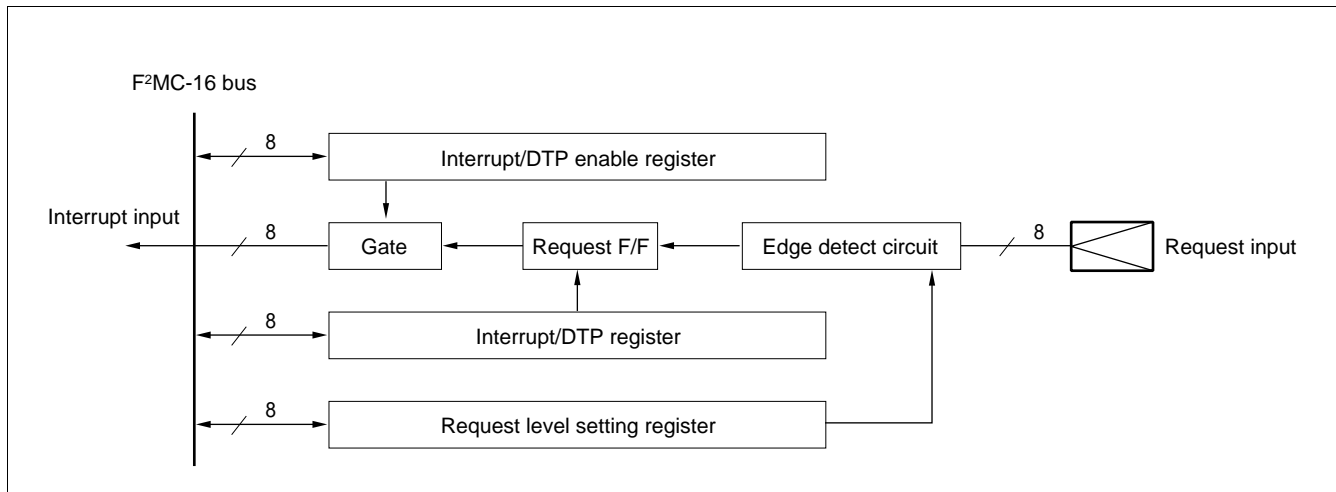

8. Delayed Interrupt Generation Module

The delayed interrupt generation module is used to generate the task switching interrupt. Interrupt requests to the F²MC-16L CPU can be generated and cleared by software using this module.

(1) Register Configuration

Delayed interrupt generate/ clear decoder Address: 00009F _H	bit	15	14	13	12	11	10	9	8	
		—	—	—	—	—	—	—	R0	DIRR
Read/write	—	(—)	(—)	(—)	(—)	(—)	(—)	(—)	(R/W)	
Initial value	—	(—)	(—)	(—)	(—)	(—)	(—)	(—)	(0)	

(2) Block Diagram

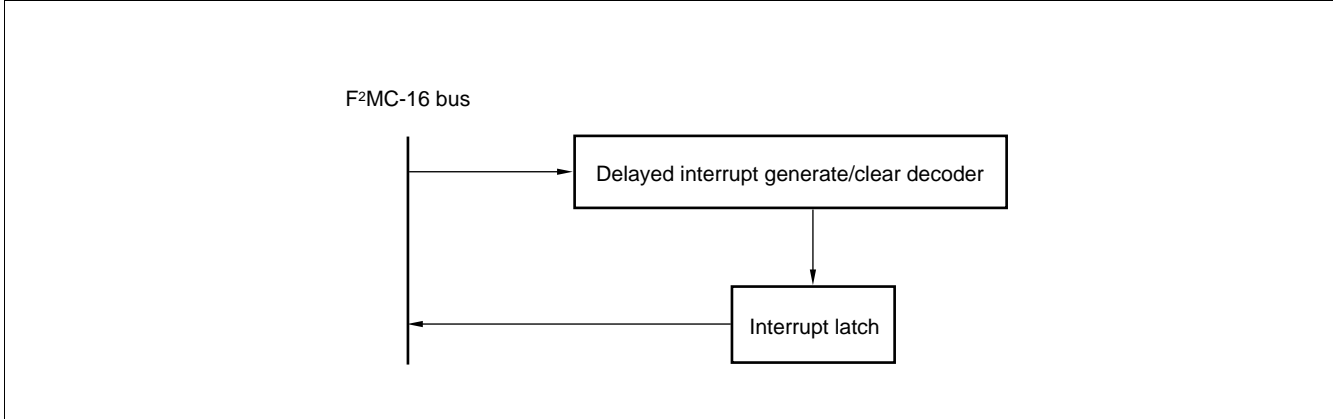

MB90610A Series

9. Watchdog Timer and Timebase Timer Functions

The watchdog timer consists of a 2-bit watchdog counter, a control register, and a watchdog reset controller. The watchdog counter uses the carry-up signal from the 18-bit timebase timer as its clock source. In addition to the 18-bit timer, the timebase timer contains an interval interrupt control circuit. The timebase timer uses the main clock, regardless of the value of the MCS bit in the CKSCR register.

(1) Register Configuration

		bit 7	6	5	4	3	2	1	0	
Watchdog timer control register Address: 0000A8 _H		PONR	STBR	WRST	ERST	SRST	WTE	WT1	WT0	WDTC
Read/write	→	(R)	(R)	(R)	(R)	(R)	(W)	(W)	(W)	
Initial value	→	(X)	(X)	(X)	(X)	(X)	(1)	(1)	(1)	

		bit 15	14	13	12	11	10	9	8	
Timebase timer control register Address: 0000A9 _H		Reserved	—	—	TBIE	TBOF	TBR	TBC1	TBC0	TBTC
Read/write	→	(—)	(—)	(—)	(R/W)	(R/W)	(W)	(R/W)	(R/W)	
Initial value	→	(1)	(—)	(—)	(0)	(0)	(1)	(0)	(0)	

(2) Block Diagram

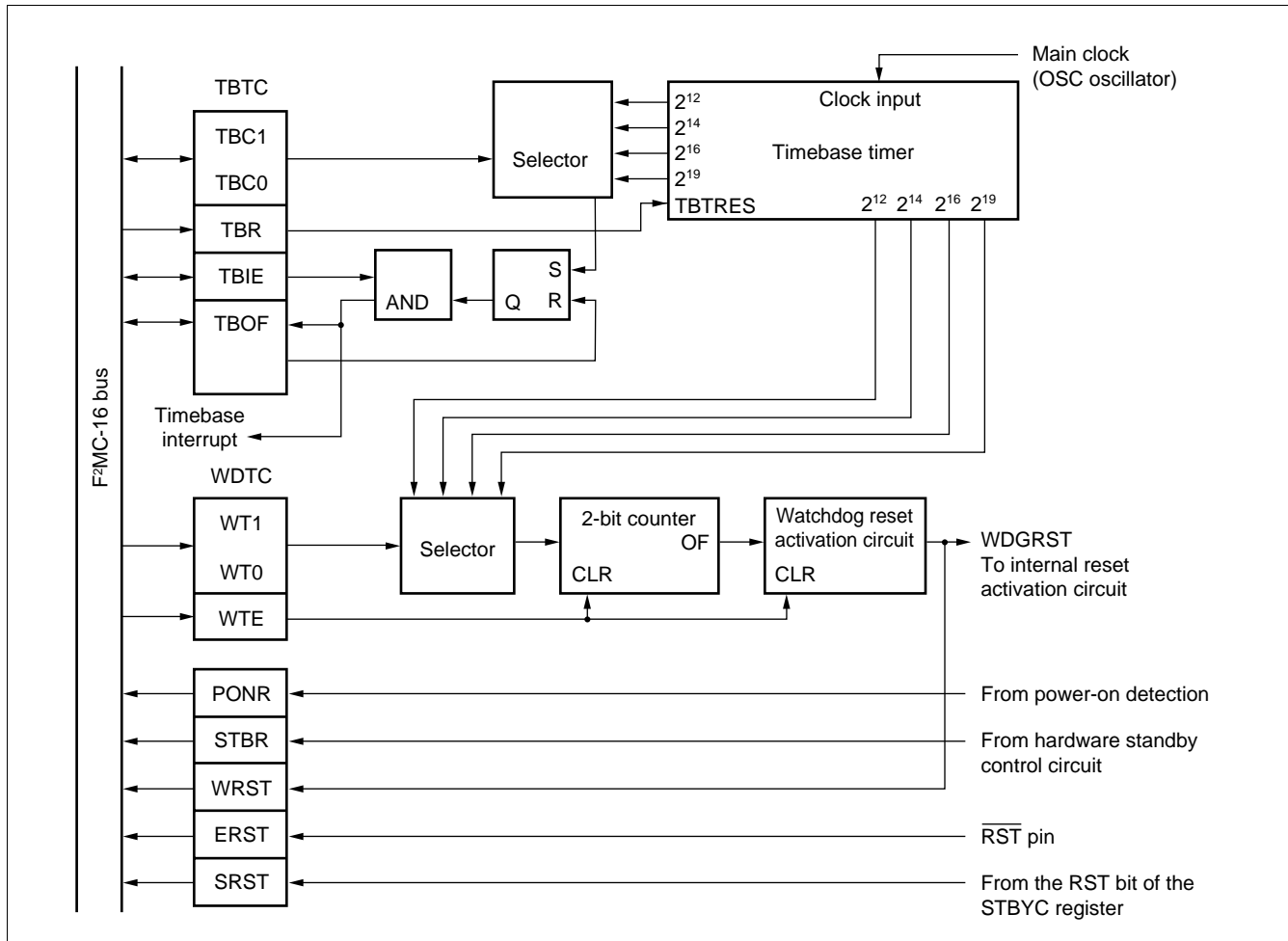

10. Low Power Control Circuits (CPU Intermittent Operation Function, Oscillation Stabilization Delay Time, and Clock Multiplier Function)

The following operation modes are available: PLL clock mode, PLL sleep mode, timer mode, main clock mode, main sleep mode, stop mode, and hardware standby mode. Operation modes other than PLL clock mode are classified as low power consumption modes.

In main clock mode and main sleep mode, the device operates on the main clock only (OSC oscillator clock). The PLL clock (VCO oscillator clock) is stopped in these modes and the main clock divided by 2 is used as the operating clock.

In PLL sleep mode and main sleep mode, the CPU's operating clock only is stopped and other elements continue to operate.

In timer mode, only the timebase timer operates.

Stop mode and hardware standby mode stop the oscillator. These modes maintain existing data with minimum power consumption.

The CPU intermittent operation function provides an intermittent clock to the CPU when register, internal memory, internal resource, or external bus access is performed. This function reduces power consumption by lowering the CPU execution speed while still providing a high-speed clock to internal resources.

The PLL clock multiplier ratio can be set to 1, 2, 3, 4 by the CS1, 0 bits.

The WS1, 0 bits set the delay time to wait for the main clock oscillation to stabilize when recovering from stop mode or hardware standby mode.

(1) Register Configuration

	bit	7	6	5	4	3	2	1	0	
Low power consumption mode control register Address: 0000A0 _H		STP	SLP	SPL	RST	Reserved	CG1	CG0	Reserved	LPMCR
Read/write →		(W)	(W)	(R/W)	(W)	(—)	(R/W)	(R/W)	(—)	
Initial value →		(0)	(0)	(0)	(1)	(1)	(0)	(0)	(0)	
	bit	15	14	13	12	11	10	9	8	
Clock select register Address: 0000A1 _H		Reserved	MCM	WS1	WS0	Reserved	MCS	CS1	CS0	CKSCR
Read/write →		(—)	(R)	(R/W)	(R/W)	(—)	(R/W)	(R/W)	(R/W)	
Initial value →		(1)	(1)	(1)	(1)	(1)	(1)	(0)	(0)	

MB90610A Series

(2) Block Diagram

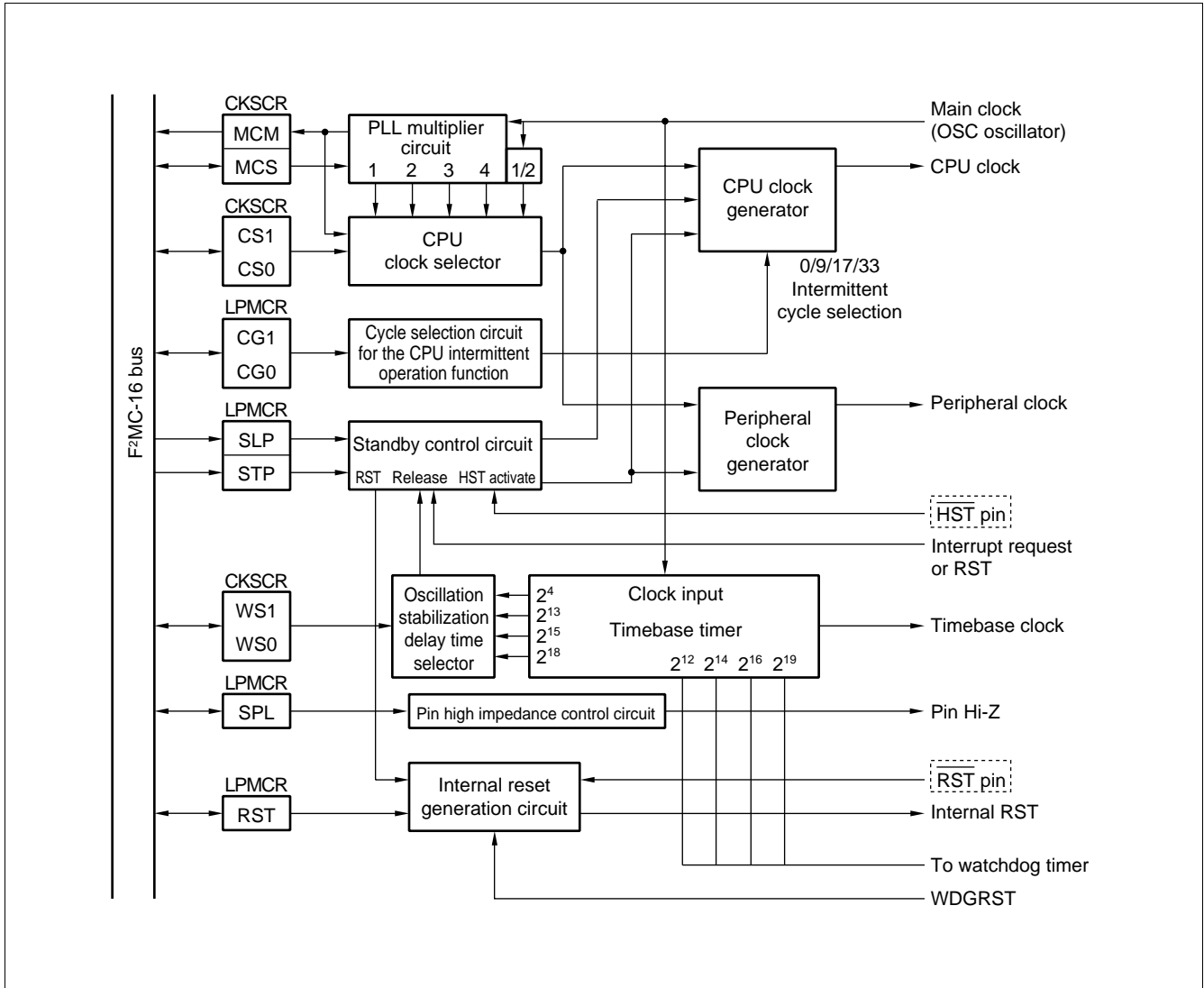

• State Transition Diagram for Clock Selection

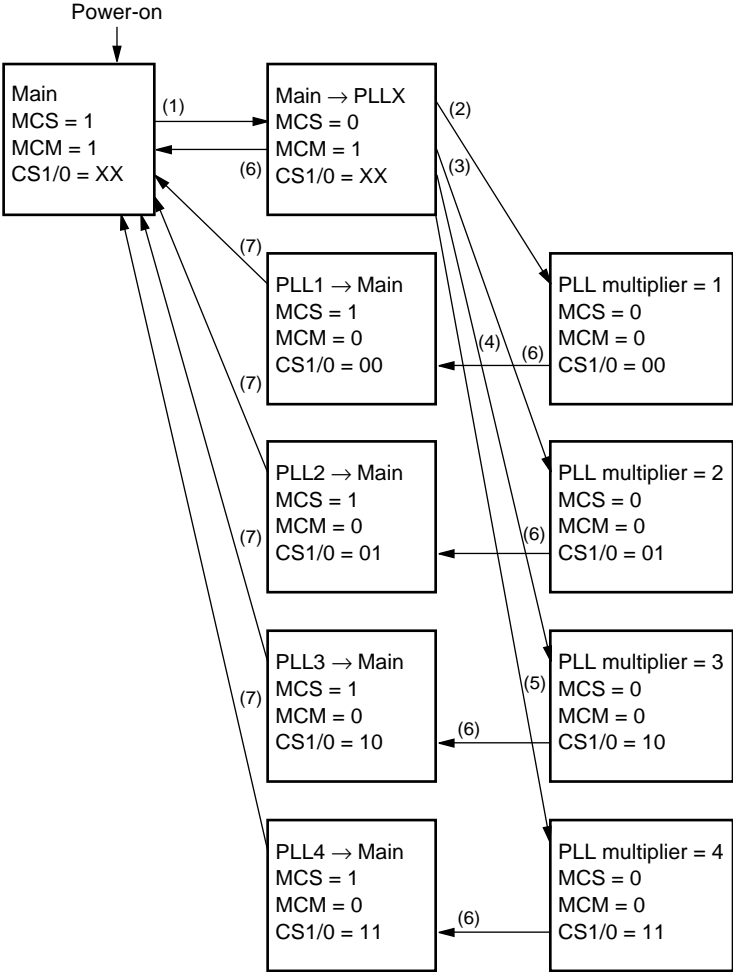

- (1) MCS bit cleared
- (2) PLL clock oscillation stabilization delay complete and CS1/0 = "00"
- (3) PLL clock oscillation stabilization delay complete and CS1/0 = "01"
- (4) PLL clock oscillation stabilization delay complete and CS1/0 = "10"
- (5) PLL clock oscillation stabilization delay complete and CS1/0 = "11"
- (6) MCS bit set (including a hardware standby or watchdog reset)
- (7) PLL clock and main clock synchronized timing

MB90610A Series

11. Interrupt Controller

The interrupt control registers are located in the interrupt controller. An interrupt control register is provided for each I/O with an interrupt function. The registers have the following three functions.

- Set the interrupt level of the corresponding peripheral.
- Select whether to treat interrupts from the corresponding peripheral as standard interrupts or activate the extended intelligent I/O service.
- Select the extended intelligent I/O service channel.

(1) Register Configuration

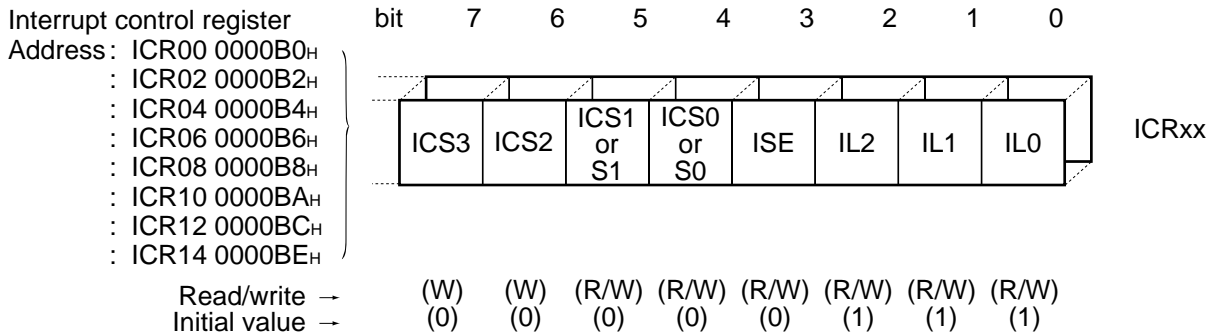
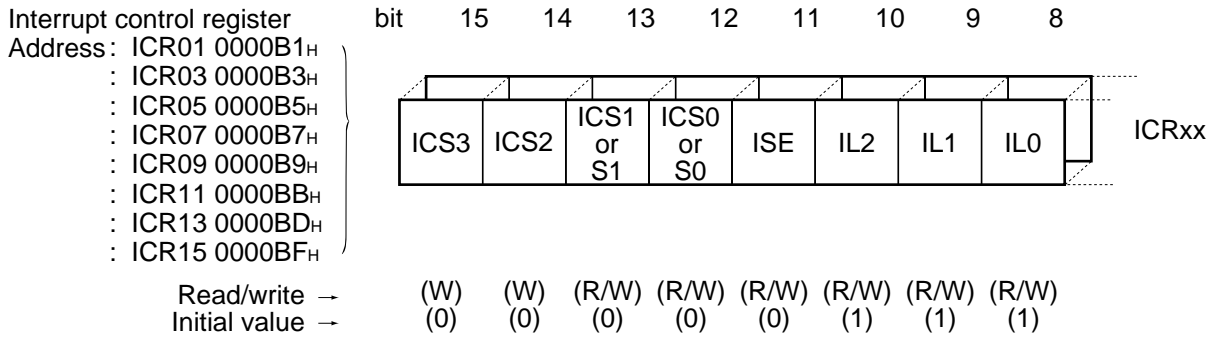

Note: Do not access these registers using read-modify-write instructions as this can cause misoperation.

(2) Block Diagram

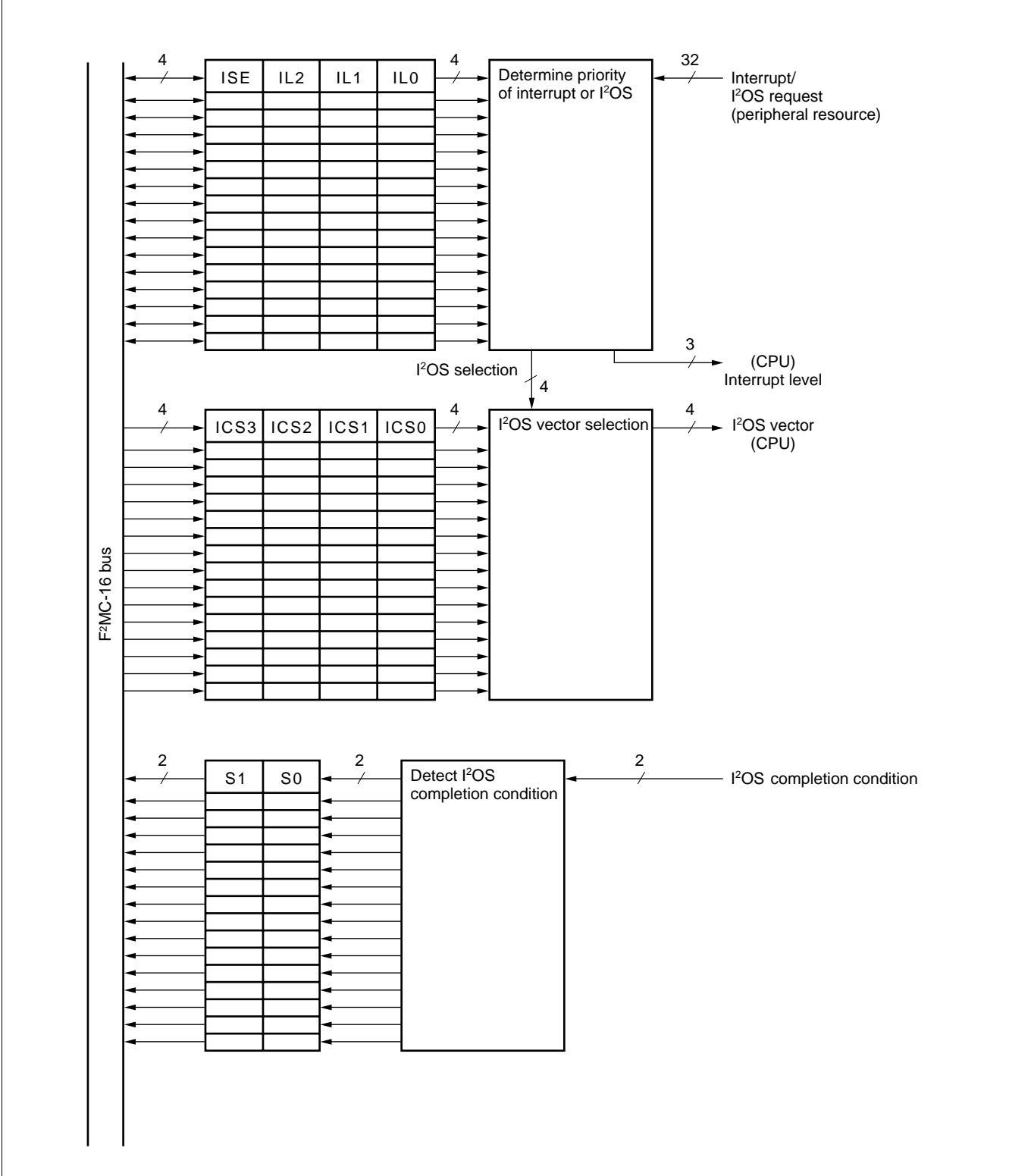

MB90610A Series

12. External Bus Terminal Control Circuit

This circuit controls the external bus terminals intended to extend outwardly the CPU's address/data bus.

(1) Register Configuration

	bit	15	14	13	12	11	10	9	8	
Register for selection of AUTO ready function Address: 0000A5 _H		IOR1	IOR0	HMR1	HMR0	—	—	LMR1	LMR0	ARSR
Read/write →		(W)	(W)	(W)	(W)	(—)	(—)	(W)	(W)	
Initial value →		(0)	(0)	(1)	(1)	(—)	(—)	(0)	(0)	
	bit	7	6	5	4	3	2	1	0	
Register for control of external address output Address: 0000A6 _H		E23	E22	E21	E20	E19	E18	E17	E16	HACR
Read/write →		(W)	(W)	(W)	(W)	(W)	(W)	(W)	(W)	
Initial value →		(0)	(0)	(0)	(0)	(0)	(0)	(0)	(0)	
	bit	15	14	13	12	11	10	9	8	
Register for selection of bus control signal Address: 0000A7 _H		—	LMBS	WRE	HMBS	IOBS	HDE	RYE	CKE	ECSR
Read/write →		(—)	(W)	(W)	(W)	(W)	(W)	(W)	(W)	
Initial value →		(—)	(0)	(0)	(1/0)	(0)	(0)	(0)	(0)	

(2) Block Diagram

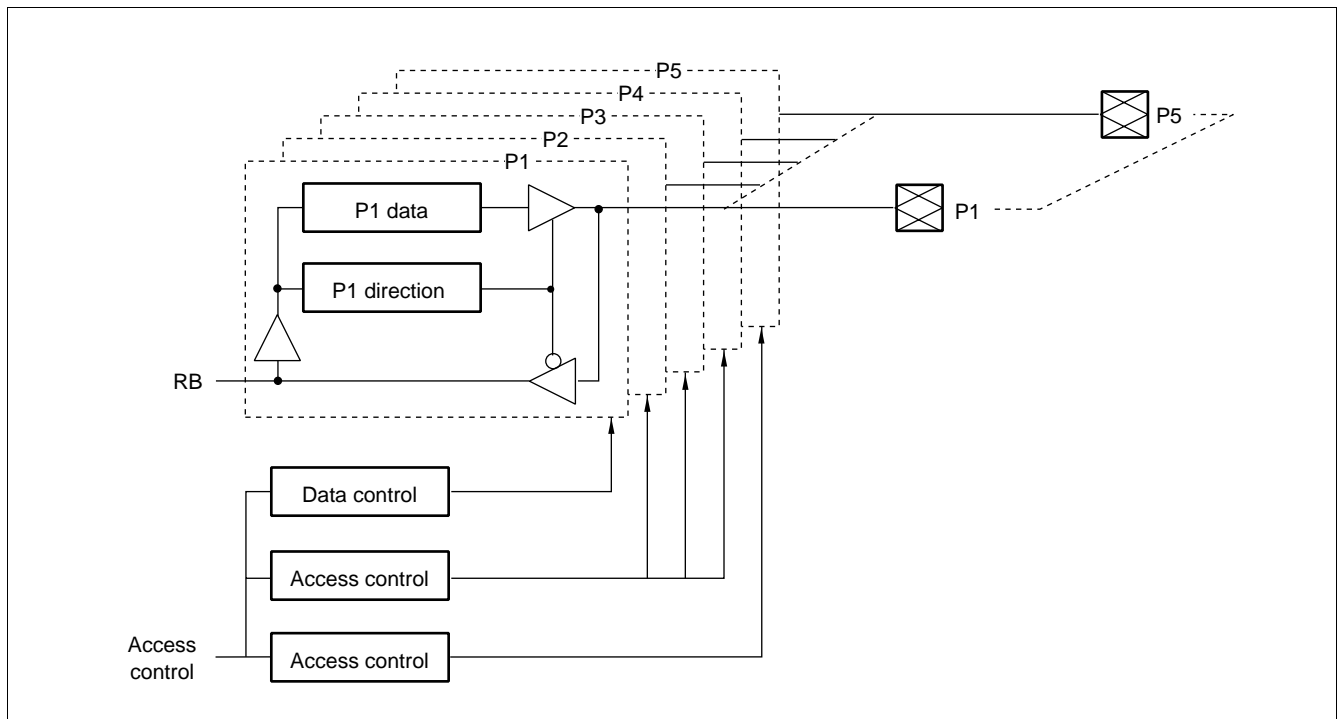

■ ELECTRICAL CHARACTERISTICS

1. Absolute Maximum Rating

($V_{SS} = AV_{SS} = 0.0\text{ V}$)

Parameter	Symbol	Rating		Unit	Remarks
		Min.	Max.		
Power supply voltage	V_{CC}	$V_{SS} - 0.3$	$V_{SS} + 7.0$	V	
	AV_{CC}^{*1}	$V_{SS} - 0.3$	$V_{SS} + 7.0$	V	
	$AVRH^{*1}$ $AVRL^{*1}$	$V_{SS} - 0.3$	$V_{SS} + 7.0$	V	
Input voltage*2	V_I	$V_{SS} - 0.3$	$V_{CC} + 0.3$	V	
Output voltage*2	V_O	$V_{SS} - 0.3$	$V_{CC} + 0.3$	V	
"L" level maximum output current*3	I_{OL}	—	15	mA	
"L" level average output current*4	I_{OLAV}	—	4	mA	
"L" level total maximum output current	ΣI_{OL}	—	100	mA	
"L" level total average output current*5	ΣI_{OLAV}	—	50	mA	
"H" level maximum output current*3	I_{OH}	—	-15	mA	
"H" level average output current*4	I_{OHAV}	—	-4	mA	
"H" level total maximum output current	ΣI_{OH}	—	-100	mA	
"H" level total average output current*5	ΣI_{OHAV}	—	-50	mA	
Power consumption	P_d	—	+400	mW	
Operating temperature	T_A	-40	+85	°C	
Storage temperature	T_{stg}	-55	+150	°C	

*1: AV_{CC} , $AVRH$, and $AVRL$ must not exceed V_{CC} . Similarly, it may not exceed $AVRL$, nor $AVRH$.

*2: V_I and V_O must not exceed $V_{CC} + 0.3\text{ V}$.

*3: The maximum output current must not be exceeded at any individual pin.

*4: The average output current is the rating for the current from an individual pin averaged over a duration of 100 ms.

*5: The average total output current is the rating for the current from all pins averaged over a duration of 100 ms.

WARNING: Semiconductor devices can be permanently damaged by application of stress (voltage, current, temperature, etc.) in excess of absolute maximum ratings. Do not exceed these ratings.

MB90610A Series

2. Recommended Operating Conditions

(V_{SS} = 0.0 V)

Parameter	Symbol	Rating		Unit	Remarks
		Min.	Max.		
Power supply voltage	V _{CC}	2.7	5.5	V	For normal operation
		2.0	5.5	V	To maintain statuses in stop mode
Operating temperature	T _A	-40	+85	°C	

WARNING: Recommended operating conditions are normal operating ranges for the semiconductor device. All the device's electrical characteristics are warranted when operated within these ranges.

Always use semiconductor devices within the recommended operating conditions. Operation outside these ranges may adversely affect reliability and could result in device failure.

No warranty is made with respect to uses, operating conditions, or combinations not represented on the data sheet. Users considering application outside the listed conditions are advised to contact their FUJITSU representative beforehand.

MB90610A Series

3. DC Characteristics

($V_{CC} = +2.7\text{ V to }+5.5\text{ V}$, $V_{SS} = 0.0\text{ V}$, $T_A = -40^\circ\text{C to }+85^\circ\text{C}$)

Parameter	Symbol	Pin name	Conditions	Value			Unit	Remarks	
				Min.	Typ.	Max.			
“H” level input voltage	V_{IH}	—	—	$0.7 V_{CC}$	—	$V_{CC} + 0.3$	V		
	V_{IHS}			$0.8 V_{CC}$	—	$V_{CC} + 0.3$	V	*1	
	V_{IHM}			$V_{CC} - 0.3$	—	$V_{CC} + 0.3$	V		
	V_{IHT}			$V_{CC} = +5.0\text{ V} \pm 10\%$	2.2	—	—	V	*2
				$V_{CC} = +3.0\text{ V} \pm 10\%$	$0.7 V_{CC}$	—	—	V	*2
“L” level input voltage	V_{IL}	—	—	$V_{SS} - 0.3$	—	$0.3 V_{CC}$	V		
	V_{ILS}			$V_{SS} - 0.3$	—	$0.2 V_{CC}$	V	*1	
	V_{ILM}			$V_{SS} - 0.3$	—	$V_{SS} + 0.3$	V		
	V_{ILT}			$V_{CC} = +5.0\text{ V} \pm 10\%$	$V_{SS} - 0.3$	—	0.8	V	*2
				$V_{CC} = +3.0\text{ V} \pm 10\%$	$V_{SS} - 0.3$	—	$0.2 V_{CC}$	V	*2
“H” level output voltage	V_{OH}	Other than P60 to P67	$V_{CC} = +5.0\text{ V} \pm 10\%$ $I_{OH} = -4.0\text{ mA}$	$V_{CC} - 0.5$	—	—	V		
			$V_{CC} = +3.0\text{ V} \pm 10\%$ $I_{OH} = -1.6\text{ mA}$	$V_{CC} - 0.3$	—	—	V		
“L” level output voltage	V_{OL}	All output pins	$V_{CC} = +5.0\text{ V} \pm 10\%$ $I_{OL} = -4.0\text{ mA}$	—	—	0.4	V		
			$V_{CC} = +3.0\text{ V} \pm 10\%$ $I_{OL} = -2.0\text{ mA}$	—	—	0.4	V		
Pull-up resistance	R_{pu}	\overline{RST} , P50 to P55, \overline{RD} , ALE, PA1 to PA7, CS0	—	30	—	100	k Ω		
Supply current	I_{CC}	V_{CC}	$V_{CC} = +5.0\text{ V} \pm 10\%$ 16 MHz internal operation	—	50	70	mA		
	I_{CCS}			—	25	30	mA		
	I_{CC}		$V_{CC} = +3.0\text{ V} \pm 10\%$ 8 MHz internal operation	—	10	20	mA		
	I_{CCS}			—	5	10	mA		
	I_{CCH}			$V_{CC} = +5.0\text{ V} \pm 10\%$ $T_A = 25^\circ\text{C}$	—	0.1	10	μA	
Input pin capacitance	C_{IN}	Other than AV_{CC} , AV_{SS} , V_{CC} , V_{SS}	—	—	10	—	pF		
Input leakage current	I_{IL}	Other than P60 to P67	$V_{CC} = 5.5\text{ V}$ $V_{SS} < V_I < V_{CC}$	-10	—	10	μA		
Leakage current for open drain outputs	I_{leak}	Other than P60 to P67	—	—	0.1	10	μA		
Pull-down resistance	R_{pd}	MD2	—	40	—	200	k Ω		

*1: Hysteresis input pins: \overline{RST} , \overline{HST} , P60 to P67, P70 to P76, P80 to P86, P90 to P95, PA1 to PA7

*2: TTL input pins: AD00/D00 to AD07/D07, AD08/D08/P10 to AD15/D15/P17, HRQ/P53, RDY/P51

MB90610A Series

4. AC Characteristics

(1) Clock Timing

- When $V_{CC} = +5.0\text{ V} \pm 10\%$

($V_{CC} = +4.5\text{ V}$ to $+5.5\text{ V}$, $V_{SS} = 0.0\text{ V}$, $T_A = -40^\circ\text{C}$ to $+85^\circ\text{C}$)

Parameter	Symbol	Pin name	Conditions	Value		Unit	Remarks
				Min.	Max.		
Clock frequency	f_c	X0, X1	—	3	32	MHz	
Clock cycle time	t_c	X0, X1	—	31.25	333	ns	
Frequency variation ratio* (when locked)	Δf	—	—	—	3	%	
Input clock pulse width	P_{WH} P_{WL}	X0	—	10	—	ns	The duty ratio should be in the range 30 to 70%
Input clock rise time and fall time	t_{cr} t_{cf}	X0	—	—	5	ns	
Internal operating clock frequency	f_{CP}	—	—	1.5	16	MHz	
Internal operating clock cycle time	t_{CP}	—	—	62.5	666	ns	

* : The frequency variation ratio is the maximum variation from the specified central frequency when the multiplier PLL is locked. The value is expressed as a proportion.

$$\Delta f = \frac{|\alpha|}{f_0} \times 100 (\%)$$

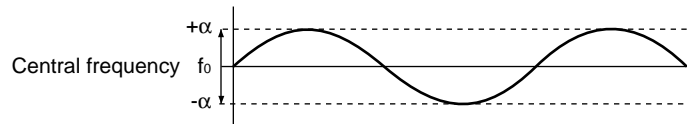

- When $V_{CC} = +2.7\text{ V}$ (min.)

($V_{CC} = +2.7\text{ V}$ to $+5.5\text{ V}$, $V_{SS} = 0.0\text{ V}$, $T_A = -40^\circ\text{C}$ to $+85^\circ\text{C}$)

Parameter	Symbol	Pin name	Conditions	Value		Unit	Remarks
				Min.	Max.		
Clock frequency	f_c	X0, X1	—	3	16	MHz	
Clock cycle time	t_c	X0, X1	—	62.5	333	ns	
Input clock pulse width	P_{WH} P_{WL}	X0	—	20	—	ns	The duty ratio should be in the range 30 to 70%
Input clock rise time and fall time	t_{cr} t_{cf}	X0	—	—	5	ns	
Internal operating clock frequency	f_{CP}	—	—	1.5	8	MHz	
Internal operating clock cycle time	t_{CP}	—	—	125	666	ns	

• Clock Timing

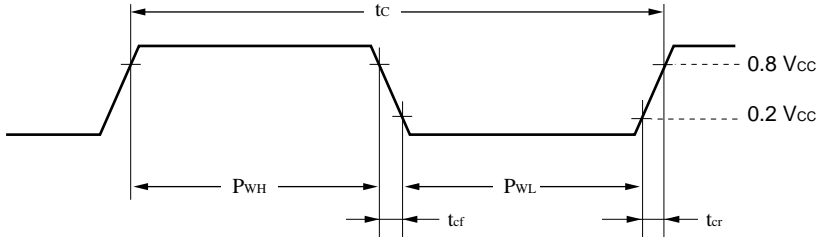

• PLL Operation Assurance Range

Relationship between the internal operating clock frequency and supply voltage

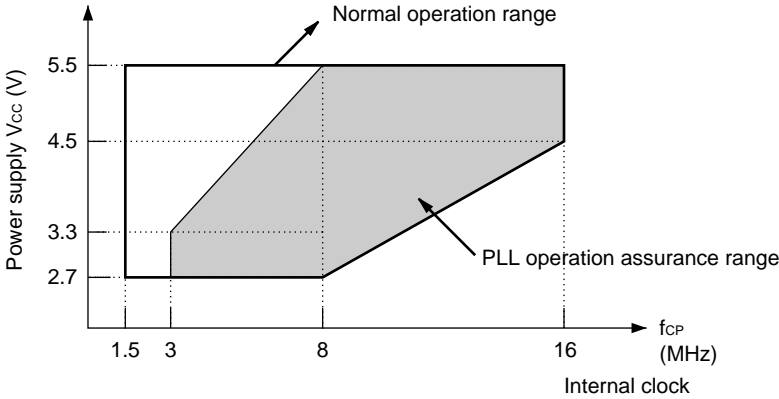

Relationship between the oscillation frequency and internal operating clock frequency

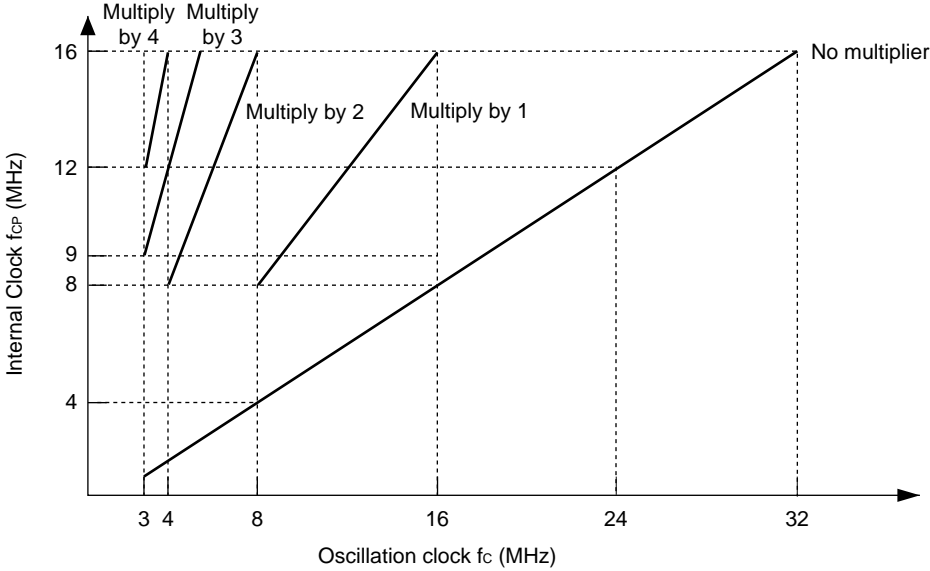

Note: Low voltage operation down to 2.7V is also assured for the evaluation tools.

MB90610A Series

The AC characteristics are for the following measurement reference voltages.

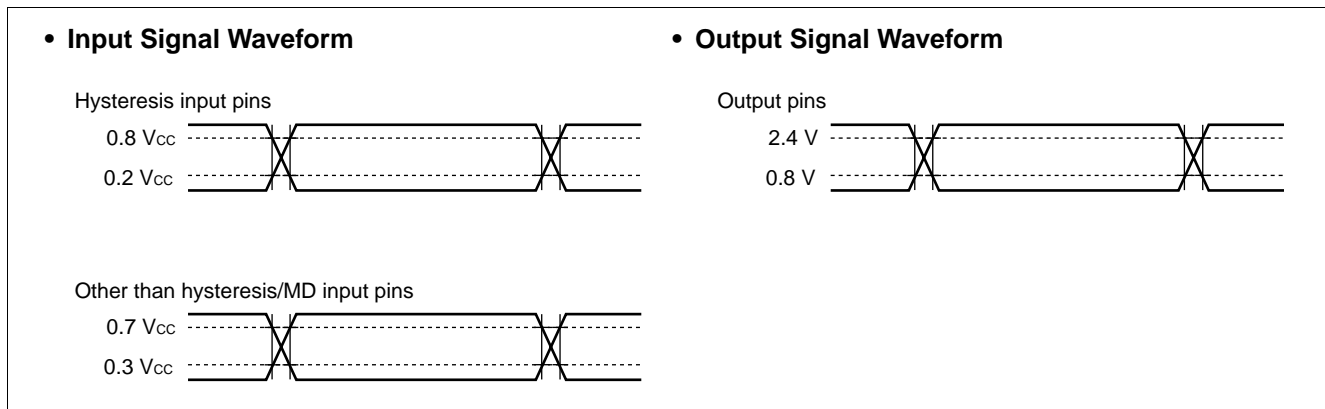

(2) Clock Output Timing

(V_{CC} = +2.7 V to +5.5 V, V_{SS} = 0.0 V, T_A = -40°C to +85°C)

Parameter	Symbol	Pin name	Conditions	Value		Unit	Remarks
				Min.	Max.		
Cycle time	t _{CYC}	CLK	V _{CC} = +5 V ± 10%	t _{CP}	—	ns	
CLK ↑ → CLK ↓	t _{CHCL}			t _{CP/2} - 20	t _{CP/2} + 20	ns	

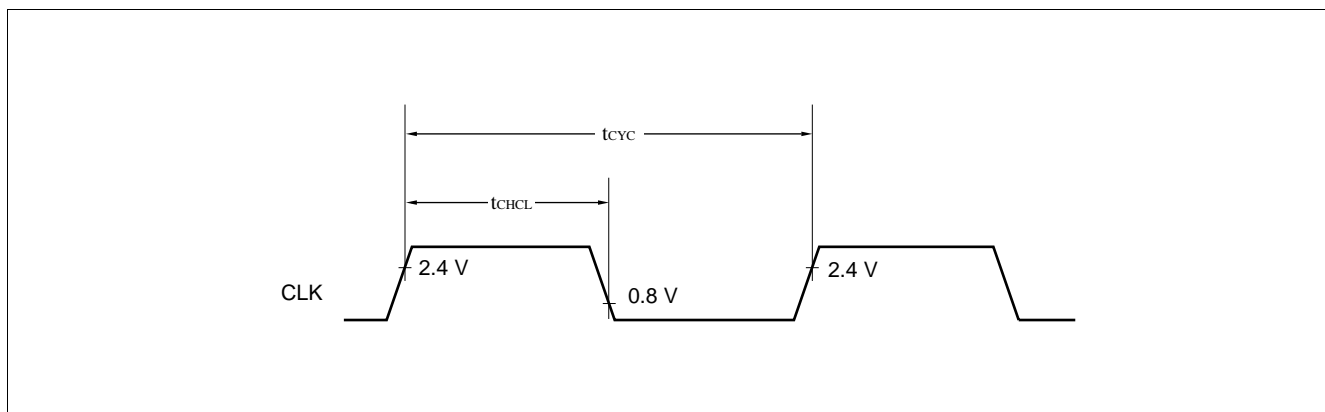

(3) Recommended Resonator Manufacturers

- **Sample Application of Piezoelectric Resonator (FAR Family)**

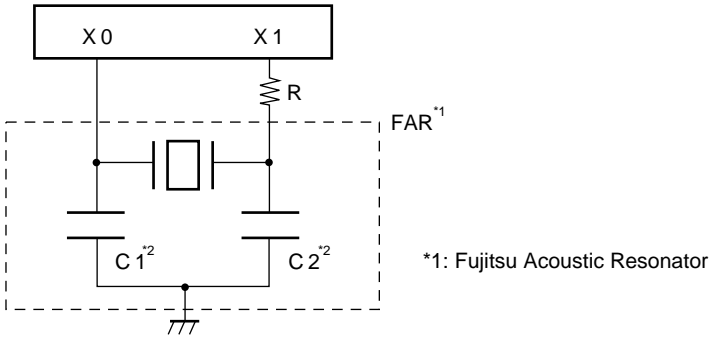

FAR part number (built-in capacitor type)	Frequency (MHz)	Dumping resistor	Initial deviation of FAR frequency (T _A = +25°C)	Temperature characteristics of FAR frequency (T _A = -20°C to +60°C)	Loading capacitors ^{*2}
FAR-C4CC-02000-L20	2.00	1 kΩ	±0.5%	±0.5%	Built-in
FAR-C4CA-04000-M01	4.00	—	±0.5%	±0.5%	
FAR-C4CB-08000-M02	8.00	—	±0.5%	±0.5%	
FAR-C4CB-10000-M02	10.00	—	±0.5%	±0.5%	
FAR-C4CB-16000-M02	16.00	—	±0.5%	±0.5%	

Inquiry: FUJITSU LIMITED

MB90610A Series

• Sample Application of Ceramic Resonator

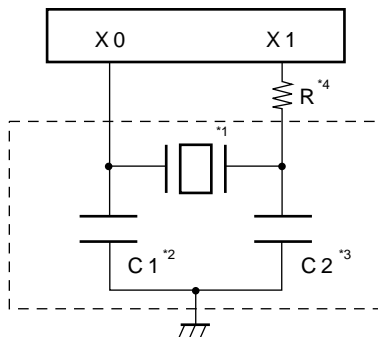

Resonator manufacturer*1	Resonator	Frequency (MHz)	C1 (pF)*2	C2 (pF)*3	R*4
Kyocera Corporation	KBR-2.0MS	2.00	150	150	Not required
	PBRC2.00A		150	150	Not required
	KBR-4.0MSA	4.00	33	33	680 Ω
	KBR-4.0MKS		Built-in	Built-in	680 Ω
	PBRC4.00A		33	33	680 Ω
	PBRC4.00B	Built-in	Built-in	680 Ω	
	KBR-6.0MSA	6.00	33	33	Not required
	KBR-6.0MKS		Built-in	Built-in	Not required
	PBRC6.00A		33	33	Not required
	PBRC6.00B	Built-in	Built-in	Not required	
	KBR-8.0M	8.00	33	33	560 Ω
	PBRC8.00A		33	33	Not required
	PBRC8.00B		Built-in	Built-in	Not required
	KBR-10.0M	10.00	33	33	330 Ω
	PBRC10.00B		Built-in	Built-in	680 Ω
	KBR-12.0M	12.00	33	33	330 Ω
PBRC12.00B	Built-in		Built-in	680 Ω	

(Continued)

MB90610A Series

(Continued)

Resonator manufacturer*1	Resonator	Frequency (MHz)	C1 (pF)*2	C2 (pF)*3	R*4
Murata Mfg. Co., Ltd.	CSA2.00MG040	2.00	100	100	Not required
	CST2.00MG040		Built-in	Built-in	Not required
	CSA4.00MG040	4.00	100	100	Not required
	CST4.00MGW040		Built-in	Built-in	Not required
	CSA6.00MG	6.00	30	30	Not required
	CST6.00MGW		Built-in	Built-in	Not required
	CSA8.00MTZ	8.00	30	30	Not required
	CST8.00MTW		Built-in	Built-in	Not required
	CSA10.00MTZ	10.00	30	30	Not required
	CST10.00MTW		Built-in	Built-in	Not required
	CSA12.00MTZ	12.00	30	30	Not required
	CST12.00MTW		Built-in	Built-in	Not required
	CSA16.00MXZ040	16.00	15	15	Not required
	CST16.00MXW0C3		Built-in	Built-in	Not required
	CSA20.00MXZ040	20.00	10	10	Not required
CSA24.00MXZ040	24.00	5	5	Not required	
CSA32.00MXZ040	32.00	5	5	Not required	

Inquiry: Kyocera Corporation

- AVX Corporation
North American Sales Headquarters: TEL 1-803-448-9411
- AVX Limited
European Sales Headquarters: TEL 44-1252-770000
- AVX/Kyocera H.K. Ltd.
Asian Sales Headquarters: TEL 852-363-3303

Murata Mfg. Co., Ltd.

- Murata Electronics North America, Inc.: TEL 1-404-436-1300
- Murata Europe Management GmbH: TEL 49-911-66870
- Murata Electronics Singapore (Pte.) Ltd.: TEL 65-758-4233

MB90610A Series

(4) Reset and Hardware Standby Inputs

($V_{CC} = +2.7\text{ V to }+5.5\text{ V}$, $V_{SS} = 0.0\text{ V}$, $T_A = -40^\circ\text{C to }+85^\circ\text{C}$)

Parameter	Symbol	Pin name	Conditions	Value		Unit	Remarks
				Min.	Max.		
Reset input time	t_{RSTL}	\overline{RST}	—	16 t_{CP}	—	ns	
Hardware standby input time	t_{HSTL}	\overline{HST}		16 t_{CP}	—	ns	

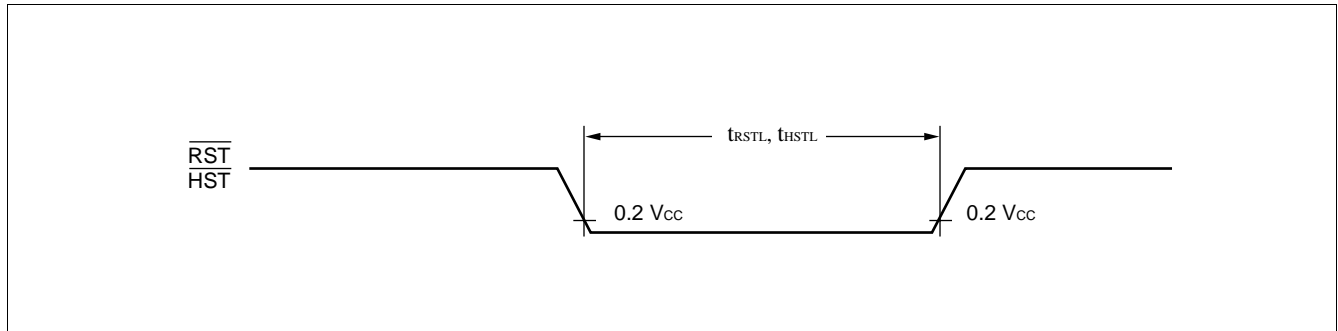

• Conditions for Measurement of AC Reference

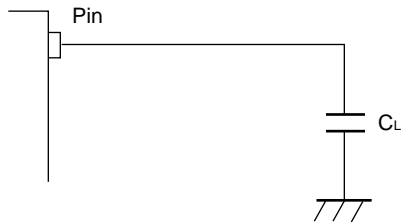

C_L : Load capacity during testing

For CLK and ALE, $C_L = 30\text{ pF}$.

For address and data buses (AD15 to AD00),
RD and WR, $C_L = 80\text{ pF}$.

(5) Power-on Reset

($V_{CC} = +2.7\text{ V to }+5.5\text{ V}$, $V_{SS} = 0.0\text{ V}$, $T_A = -40^\circ\text{C to }+85^\circ\text{C}$)

Parameter	Symbol	Pin name	Conditions	Value		Unit	Remarks
				Min.	Max.		
Power supply rise time	t_R	V_{CC}	—	—	30	ms	*
Power supply cut-off time	t_{OFF}	V_{CC}		1	—	ms	For repetition of the operation

* : V_{CC} should be lower than 0.2 V before power supply rise.

- Notes:
- The above values are the values required for a power-on reset
 - When $\overline{HST} = \text{"L"}$, this standard must be followed to turn on power supply for power-on reset whether or not necessary.
 - The device has built-in registers which are initialized only by power-on reset. For possible initialization of these registers, turn on power supply according to this standard.

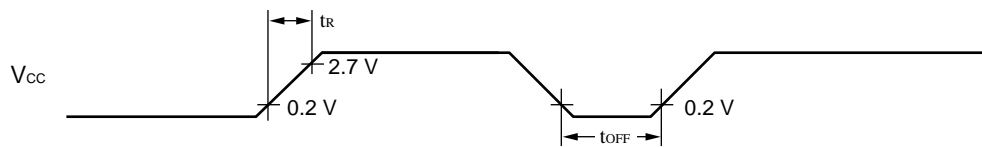

Abrupt changes in the power supply voltage may cause a power-on reset.
When changing the power supply voltage during operation, the change should be as smooth as possible, as shown in the following figure.

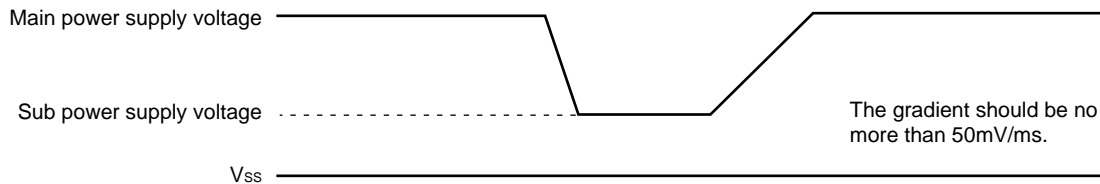

MB90610A Series

(6) Bus Timing (Read)

($V_{CC} = +2.7\text{ V to }+5.5\text{ V}$, $V_{SS} = 0.0\text{ V}$, $T_A = -40^\circ\text{C to }+85^\circ\text{C}$)

Parameter	Symbol	Pin name	Conditions	Value		Unit	Remarks
				Min.	Max.		
ALE pulse width	t_{LHLL}	ALE	$V_{CC} = +5.0\text{ V}\pm 10\%$	$t_{CP}/2 - 20$	—	ns	
			$V_{CC} = +3.0\text{ V}\pm 10\%$	$t_{CP}/2 - 35$	—	ns	
Valid address \rightarrow ALE \downarrow time	t_{AVLL}	Address	$V_{CC} = +5.0\text{ V}\pm 10\%$	$t_{CP}/2 - 20$	—	ns	
			$V_{CC} = +3.0\text{ V}\pm 10\%$	$t_{CP}/2 - 40$	—	ns	
ALE $\downarrow \rightarrow$ address valid time	t_{LLAX}	Address	—	$t_{CP}/2 - 15$	—	ns	
Valid address $\rightarrow \overline{RD} \downarrow$ time	t_{AVRL}	\overline{RD} , Address		$t_{CP} - 15$	—	ns	
Valid address \rightarrow valid data input	t_{AVDV}	Address/ data	$V_{CC} = +5.0\text{ V}\pm 10\%$	—	$5 t_{CP}/2 - 60$	ns	
			$V_{CC} = +3.0\text{ V}\pm 10\%$	—	$5 t_{CP}/2 - 80$	ns	
\overline{RD} pulse width	t_{RLRH}	\overline{RD}	—	$3 t_{CP}/2 - 20$	—	ns	
$\overline{RD} \downarrow \rightarrow$ valid data input	t_{RLDV}	Data	$V_{CC} = +5.0\text{ V}\pm 10\%$	—	$3 t_{CP}/2 - 60$	ns	
			$V_{CC} = +3.0\text{ V}\pm 10\%$		$3 t_{CP}/2 - 80$	ns	
$\overline{RD} \uparrow \rightarrow$ data hold time	t_{RHDX}			0	—	ns	
$\overline{RD} \uparrow \rightarrow$ ALE \uparrow time	t_{RHLL}	\overline{RD} , ALE	—	$t_{CP}/2 - 15$	—	ns	
$\overline{RD} \uparrow \rightarrow$ address valid time	t_{RHAX}	Address, \overline{RD}		$t_{CP}/2 - 10$	—	ns	
Valid address \rightarrow CLK \uparrow time	t_{AVCH}	Address, CLK		$t_{CP}/2 - 20$	—	ns	
$\overline{RD} \downarrow \rightarrow$ CLK \uparrow time	t_{RLCH}	\overline{RD} , CLK		$t_{CP}/2 - 20$	—	ns	

MB90610A Series

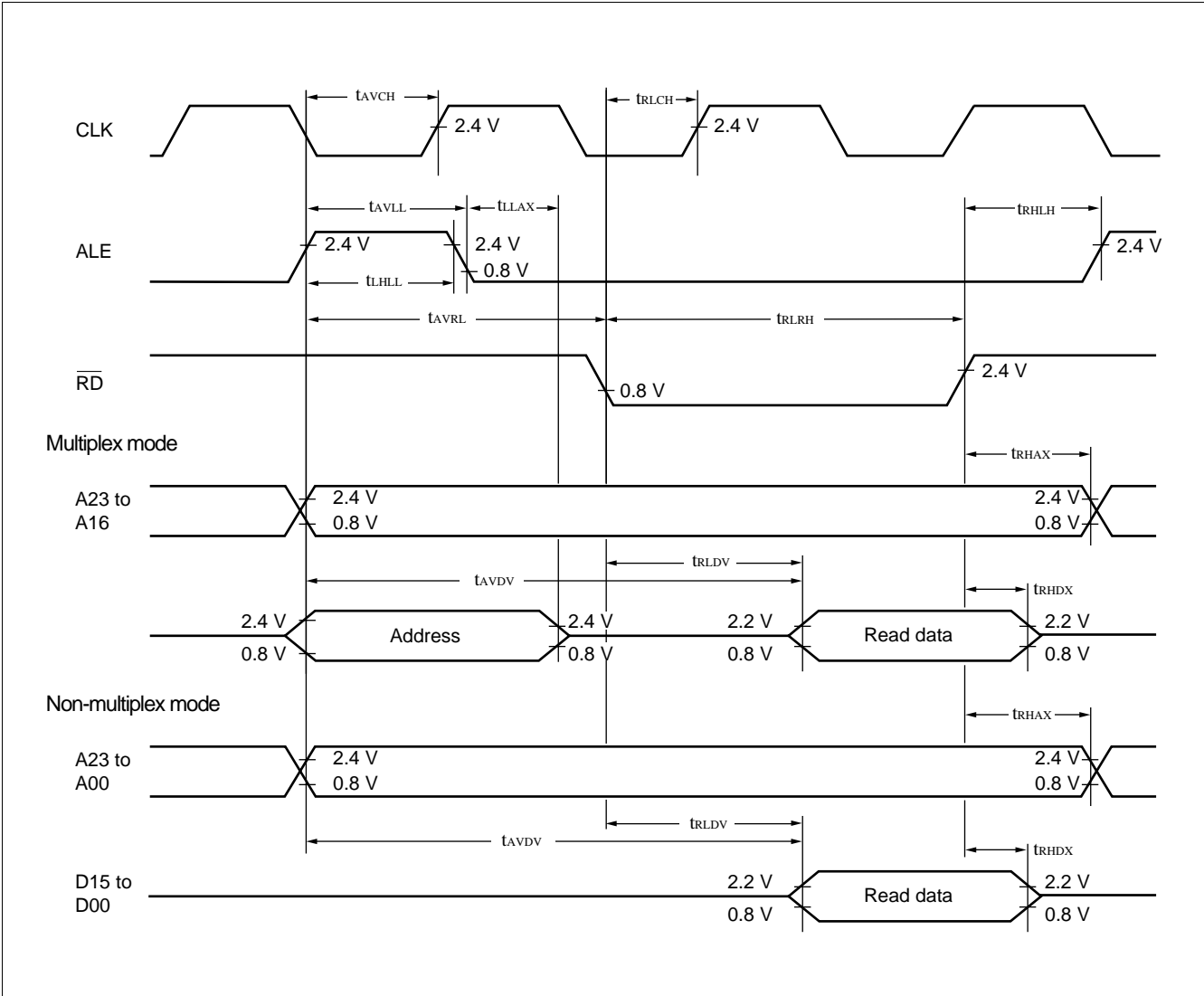

MB90610A Series

(7) Bus Timing (Write)

($V_{CC} = +2.7\text{ V to }+5.5\text{ V}$, $V_{SS} = 0.0\text{ V}$, $T_A = -40^\circ\text{C to }+85^\circ\text{C}$)

Parameter	Symbol	Pin name	Conditions	Value		Unit	Remarks
				Min.	Max.		
Valid address $\rightarrow \overline{WR} \downarrow$ time	t_{AVWL}	Address	—	$t_{CP} - 15$	—	ns	
\overline{WR} pulse width	t_{WLWH}	\overline{WRL} , \overline{WRH}		$3 t_{CP}/2 - 20$	—	ns	
Valid data output $\rightarrow \overline{WR} \uparrow$ time	t_{DVWH}	Data		$3 t_{CP}/2 - 20$	—	ns	
$\overline{WR} \uparrow \rightarrow$ data hold time	t_{WHDX}		$V_{CC} = +5.0\text{ V} \pm 10\%$	20	—	ns	
		$V_{CC} = +3.0\text{ V} \pm 10\%$	30	—	ns		
$\overline{WR} \uparrow \rightarrow$ address valid time	t_{WHAX}	Address	—	$t_{CP}/2 - 10$	—	ns	
$\overline{WR} \uparrow \rightarrow$ ALE \uparrow time	t_{WHLH}	\overline{ALE} , \overline{WRL} , \overline{WRH}		$t_{CP}/2 - 15$	—	ns	
$\overline{WR} \downarrow \rightarrow$ CLK \downarrow time	t_{WLCL}	\overline{WRL} , \overline{WRH} , CLK		$t_{CP}/2 - 20$	—	ns	

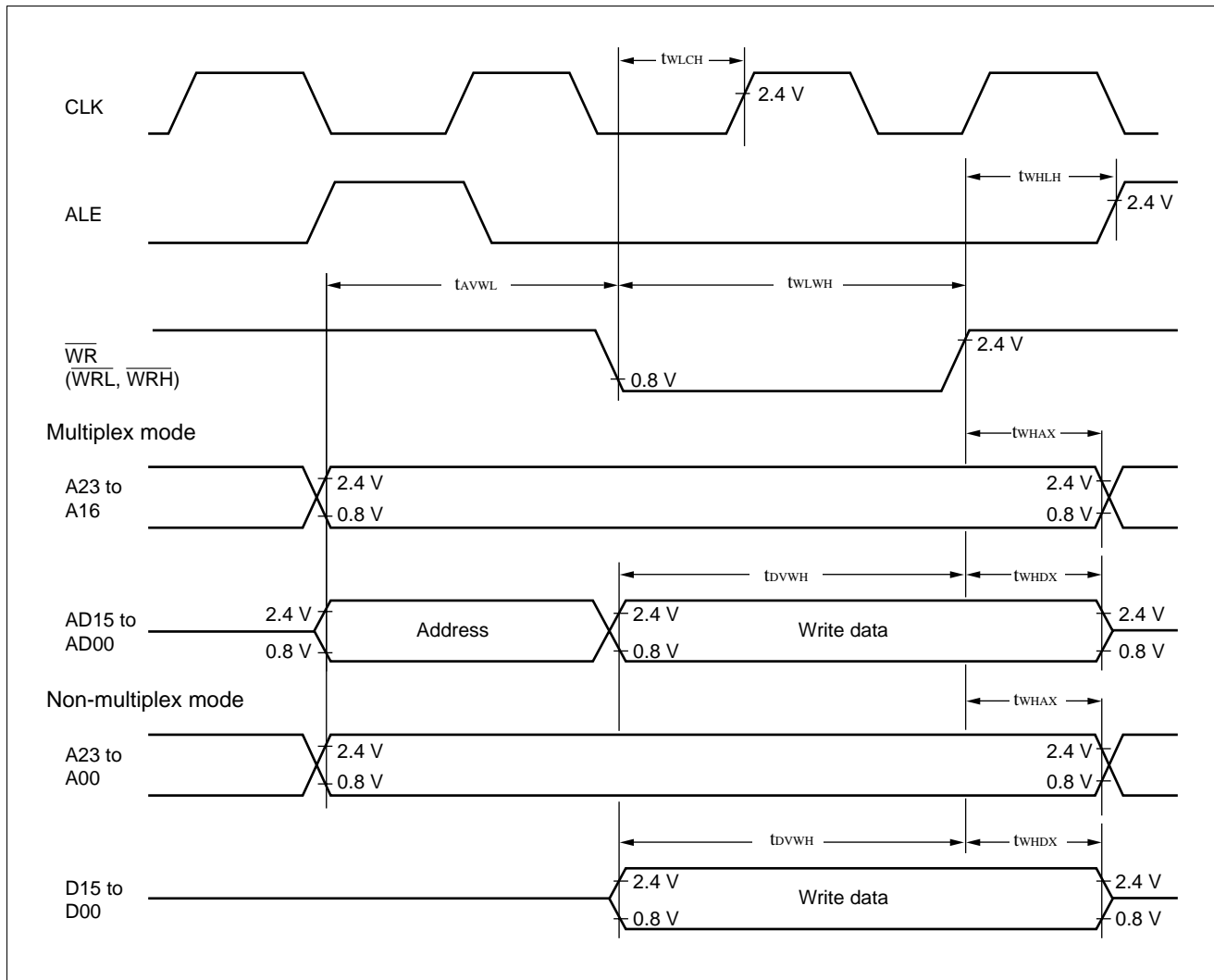

(8) Ready Input Timing

($V_{CC} = +2.7\text{ V to }+5.5\text{ V}$, $V_{SS} = 0.0\text{ V}$, $T_A = -40^\circ\text{C to }+85^\circ\text{C}$)

Parameter	Symbol	Pin name	Conditions	Value		Unit	Remarks
				Min.	Max.		
RDY setup time	t_{RYHS}	RDY	$V_{CC} = +5.0\text{ V} \pm 10\%$	45	—	ns	
			$V_{CC} = +3.0\text{ V} \pm 10\%$	70	—	ns	
RDY hold time	t_{RYHH}	RDY	—	0	—	ns	

Note: Use the auto-ready function if the setup time at fall of the RDY is too short.

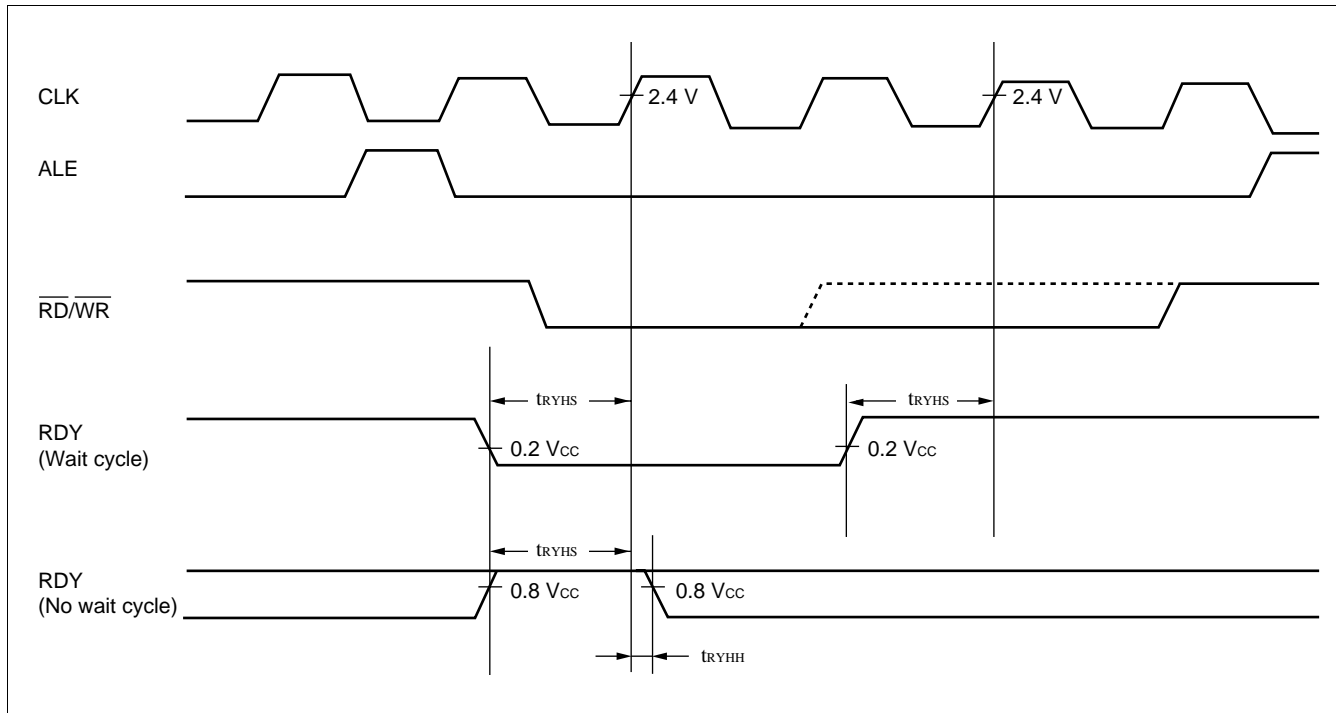

MB90610A Series

(9) Hold Timing

($V_{CC} = +2.7\text{ V to }+5.5\text{ V}$, $V_{SS} = 0.0\text{ V}$, $T_A = -40^\circ\text{C to }+85^\circ\text{C}$)

Parameter	Symbol	Pin name	Conditions	Value		Unit	Remarks
				Min.	Max.		
Pin floating $\rightarrow \overline{\text{HAK}} \downarrow$ time	t_{XHAL}	$\overline{\text{HAK}}$	—	30	t_{CP}	ns	
$\overline{\text{HAK}} \uparrow \rightarrow$ pin valid time	t_{HAHV}	$\overline{\text{HAK}}$	—	t_{CP}	$2 t_{CP}$	ns	

Note: After reading HRQ, more than one cycle is required before changing $\overline{\text{HAK}}$.

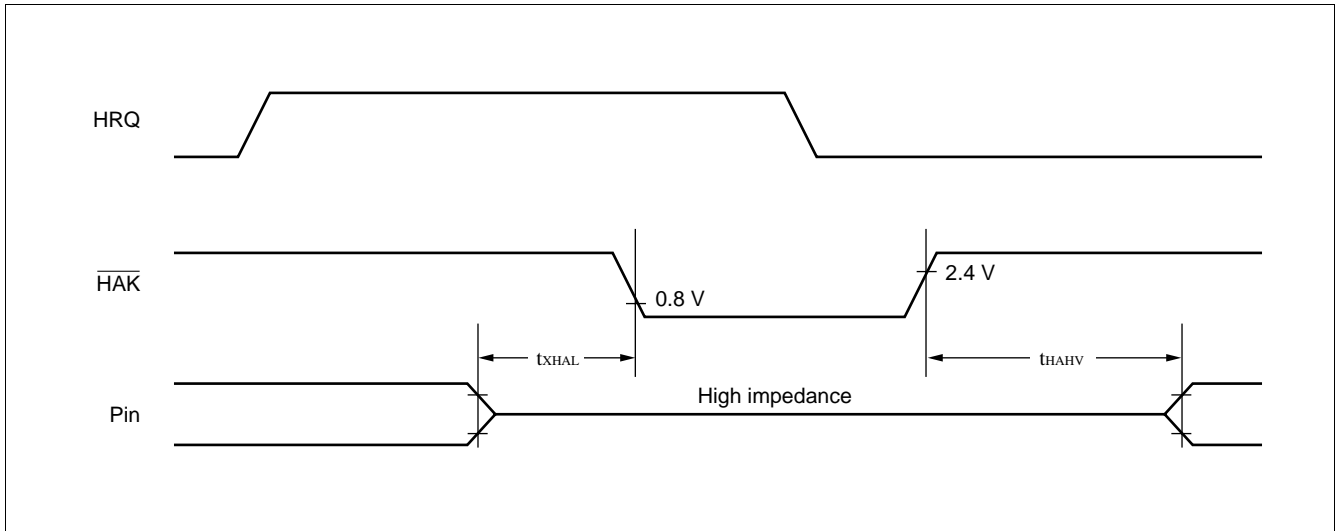

MB90610A Series

(10) I/O Expansion Serial Timing

($V_{CC} = +2.7\text{ V to }+5.5\text{ V}$, $V_{SS} = 0.0\text{ V}$, $T_A = -40^\circ\text{C to }+85^\circ\text{C}$)

Parameter	Symbol	Pin name	Conditions	Value		Unit	Remarks
				Min.	Max.		
Serial clock cycle time	t_{SCYC}	SCK0 to 2	—	$8 t_{CP}$	—	ns	$C_L = 80\text{ pF} + 1$ TTL for the internal shift clock mode output pin.
SCK ↓ → SOT delay time	t_{SLOV}	SCK0 to 2 SOT0 to 2	$V_{CC} = +5.0\text{ V} \pm 10\%$	-80	80	ns	
			$V_{CC} = +3.0\text{ V} \pm 10\%$	-120	120	ns	
Valid SIN → SCK ↑	t_{IVSH}	SCK0 to 2 SIN0 to 2	$V_{CC} = +5.0\text{ V} \pm 10\%$	100	—	ns	
			$V_{CC} = +3.0\text{ V} \pm 10\%$	200	—	ns	
SCK ↑ → valid SIN hold time	t_{SHIX}	SCK0 to 2 SIN0 to 2	$V_{CC} = +5.0\text{ V} \pm 10\%$	60	—	ns	
			$V_{CC} = +3.0\text{ V} \pm 10\%$	120	—	ns	
Serial clock "H" pulse width	t_{SHSL}	SCK0 to 2	—	$4 t_{CP}$	—	ns	$C_L = 80\text{ pF} + 1$ TTL for the external shift clock mode output pin.
Serial clock "L" pulse width	t_{LSLH}	SCK0 to 2	—	$4 t_{CP}$	—	ns	
SCK ↓ → SOT delay time	t_{SLOV}	SCK0 to 2 SOT0 to 2	$V_{CC} = +5.0\text{ V} \pm 10\%$	—	150	ns	
			$V_{CC} = +3.0\text{ V} \pm 10\%$	—	200	ns	
Valid SIN → SCK ↑	t_{IVSH}	SCK0 to 2 SIN0 to 2	$V_{CC} = +5.0\text{ V} \pm 10\%$	60	—	ns	
			$V_{CC} = +3.0\text{ V} \pm 10\%$	120	—	ns	
SCK ↑ → valid SIN hold time	t_{SHIX}	SCK0 to 2 SIN0 to 2	$V_{CC} = +5.0\text{ V} \pm 10\%$	60	—	ns	
			$V_{CC} = +3.0\text{ V} \pm 10\%$	120	—	ns	

- Notes:
- These are the AC characteristics for CLK synchronous mode.
 - C_L is the load capacitance connected to the pin at testing.
 - t_{CP} is the machine cycle period (unit: ns).

MB90610A Series

• Internal Shift Clock Mode

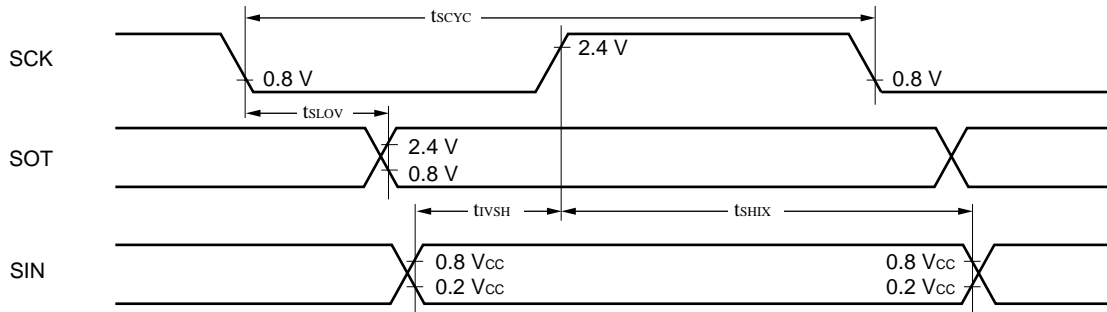

• External Shift Clock Mode

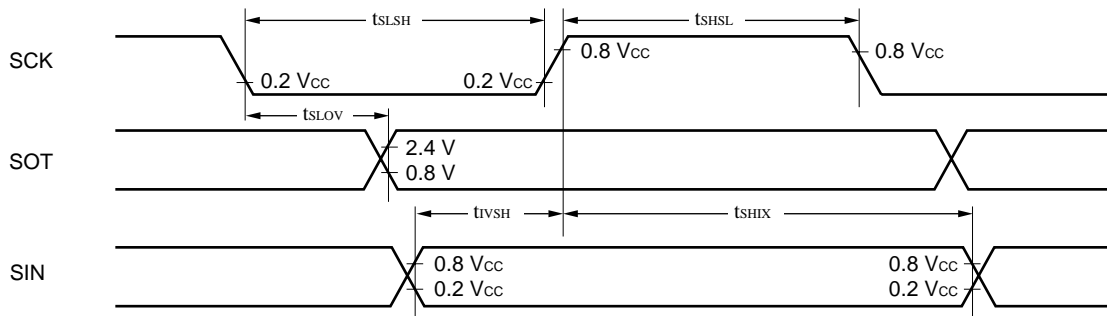

(11) Timer Input Timing

($V_{CC} = +2.7\text{ V to }+5.5\text{ V}$, $V_{SS} = 0.0\text{ V}$, $T_A = -40^\circ\text{C to }+85^\circ\text{C}$)

Parameter	Symbol	Pin name	Conditions	Value		Unit	Remarks
				Min.	Max.		
Input pulse width	$t_{TIWH/L}$	TIN0 to 1	—	4 t_{CP}	—	ns	

• Timer Input Timing

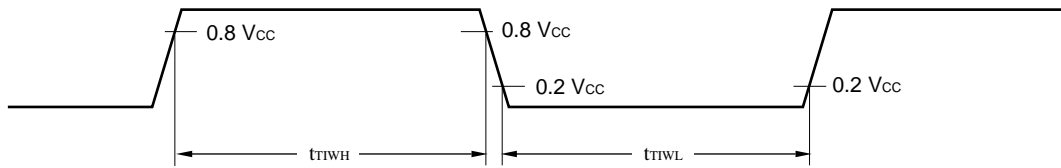

(12) Timer Output Timing

($V_{CC} = +2.7\text{ V to }+5.5\text{ V}$, $V_{SS} = 0.0\text{ V}$, $T_A = -40^\circ\text{C to }+85^\circ\text{C}$)

Parameter	Symbol	Pin name	Conditions	Value		Unit	Remarks
				Min.	Max.		
CLK \uparrow \rightarrow T _{OUT} change timing	t_{TO}	TOT0 to 1	$V_{CC} = +5.0\text{ V} \pm 10\%$	30	—	ns	
			$V_{CC} = +3.0\text{ V} \pm 10\%$	80	—	ns	

• Timer Output Timing

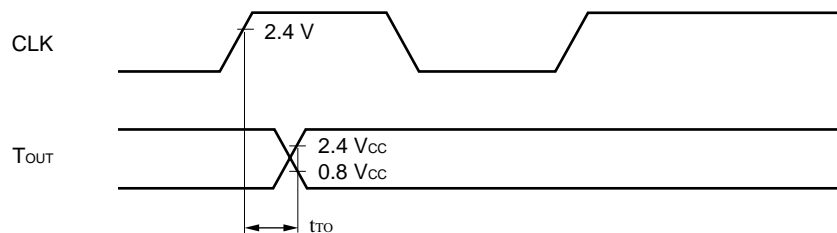

MB90610A Series

(13) Trigger Input Timing

($V_{CC} = +2.7\text{ V to }+5.5\text{ V}$, $V_{SS} = 0.0\text{ V}$, $T_A = -40^\circ\text{C to }+85^\circ\text{C}$)

Parameter	Symbol	Pin name	Conditions	Value		Unit	Remarks
				Min.	Max.		
Input pulse width	t_{TRGH} t_{TRGL}	$\overline{\text{ATG}}$ INT0 to INT1	—	5 t_{CP}	—	ns	

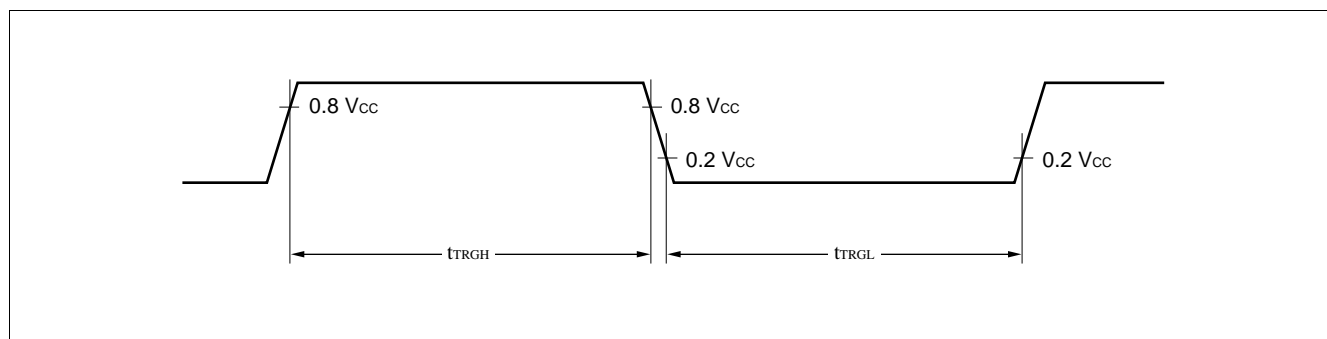

(14) Chip Select Output Timing

($V_{CC} = +2.7\text{ V to }+5.5\text{ V}$, $V_{SS} = 0.0\text{ V}$, $T_A = -40^\circ\text{C to }+85^\circ\text{C}$)

Parameter	Symbol	Pin name	Conditions	Value		Unit	Remarks
				Min.	Max.		
Chip select enabled → Valid data input time	t_{SVDV}	CS0 to CS7 D15 to D00	$V_{CC} = +5.0\text{ V} \pm 10\%$	—	$5 t_{CP}/2 - 60$	ns	
			$V_{CC} = +3.0\text{ V} \pm 10\%$	—	$5 t_{CP}/2 - 80$	ns	
$\overline{\text{RD}} \uparrow \rightarrow$ Chip select enabled time	t_{RHSV}	CS0 to CS7 RD	—	$t_{CP}/2 - 10$	—	ns	
$\overline{\text{WR}} \uparrow \rightarrow$ Chip select enabled time	t_{WHSV}	CS0 to CS7 WRH, WRL	—	$t_{CP}/2 - 10$	—	ns	
Enabled chip select → CLK ↑ time	t_{SVCH}	CS0 to CS7 CLK	—	—	$t_{CP}/2 - 20$	ns	

MB90610A Series

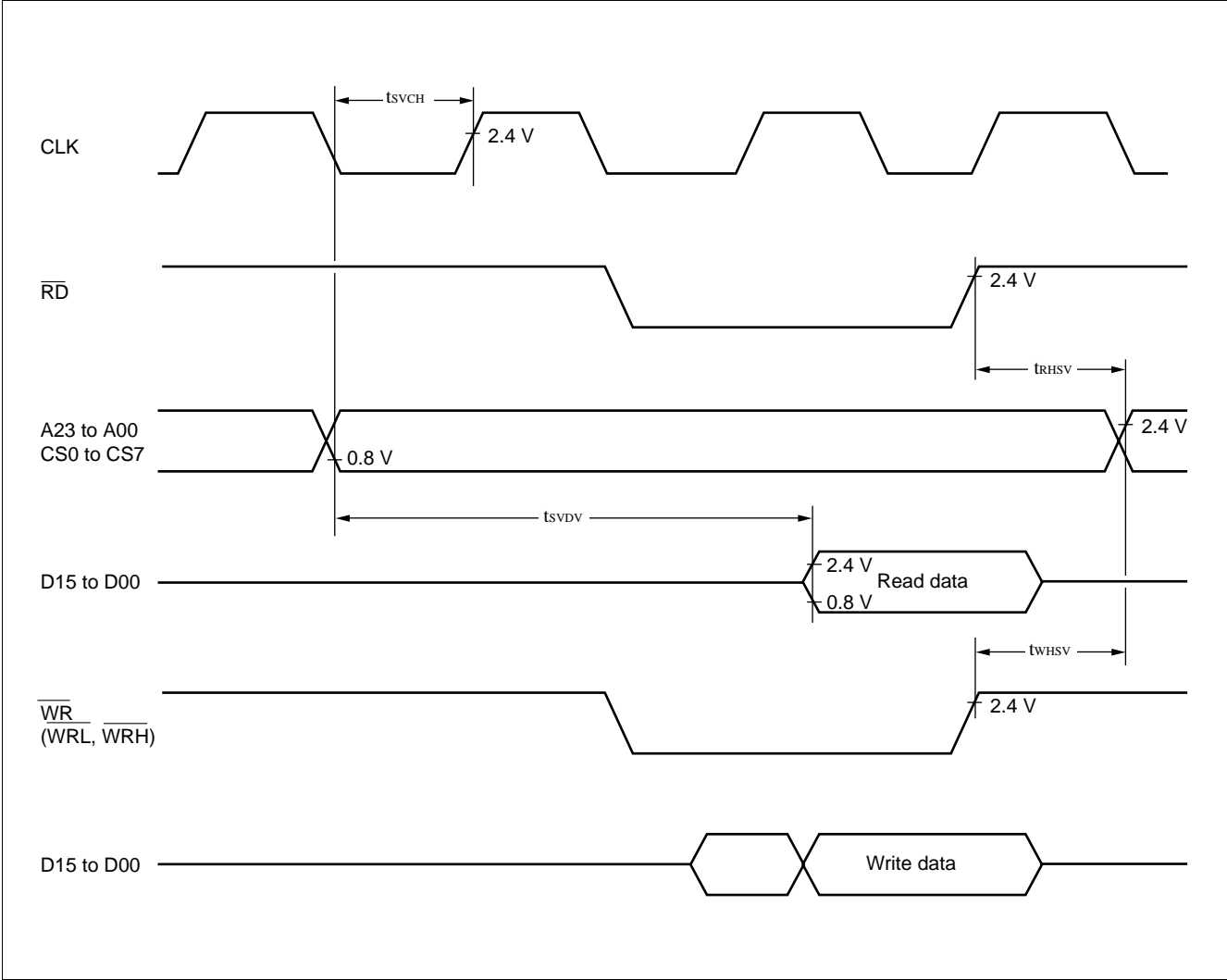

MB90610A Series

5. A/D Converter Electrical Characteristics

($AV_{CC} = V_{CC} = +2.7\text{ V to }+5.5\text{ V}$, $AV_{SS} = V_{SS} = 0.0\text{ V}$, $2.7\text{ V} \leq AVR_H - AVR_L$, $T_A = -40^\circ\text{C to }+85^\circ\text{C}$)

Parameter	Symbol	Pin name	Value			Unit
			Min.	Typ.	Max.	
Resolution	—	—	—	10	10	bit
Total error	—	—	—	—	± 3.0	LSB
Linearity error	—	—	—	—	± 2.0	LSB
Differential linearity error	—	—	—	—	± 1.5	LSB
Zero transition voltage	V_{OT}	AN0 to AN7	$AVRL - 1.5$	$AVRL + 0.5$	$AVRL + 2.5$	LSB
Full scale transition voltage	V_{FST}	AN0 to AN7	$AVRH - 4.5$	$AVRH - 1.5$	$AVRH + 0.5$	LSB
Conversion time	—	—	6.125*1	—	—	μs
			12.25*2	—	—	μs
Analog port input current	I_{AIN}	AN0 to AN7	—	0.1	10	μA
Analog input voltage	V_{AIN}	AN0 to AN7	AVRL	—	AVRH	V
Reference voltage	—	AVRH	$AVRL + 2.7$	—	AV_{CC}	V
	—	AVRL	0	—	$AVRH - 2.7$	V
Power supply current	I_A	AV_{CC}	—	3	—	mA
	I_{AH}	AV_{CC}	—	—	5^3	μA
Reference voltage supply current	I_R	AVRH	—	200	—	μA
	I_{RH}	AVRH	—	—	5^3	μA
Variation between channels	—	AN0 to AN7	—	—	4	LSB

*1: For $V_{CC} = +5.0\text{ V} \pm 10\%$ and a 16 MHz machine clock

*2: For $V_{CC} = +3.0\text{ V} \pm 10\%$ and a 8 MHz machine clock

*3: The current when the A/D converter is not operating or the CPU is in stop mode (for $V_{CC} = AV_{CC} = AVR_H = +5.0\text{ V}$).

Notes: • The relative error increases as $|AVRH - AVR_L|$ decreases.

• The output impedance of the external circuit for the analog input should be in the following range.

Output impedance of external circuit < approx. 7 k Ω

• If the output impedance of the external circuit is too high, the sampling time for the analog voltage may be too short. (Sampling time = 3.75 μs @ 4 MHz (This corresponds to 16 MHz internal operation if the multiplier is 4.))

• For an external capacitor to be provided outside the chip, its capacity should desirably be thousands times larger than that of the capacity in the chip taking in consideration the influence of the capacity distribution of the external and internal capacitors.

• Model of The Analog Input Circuit

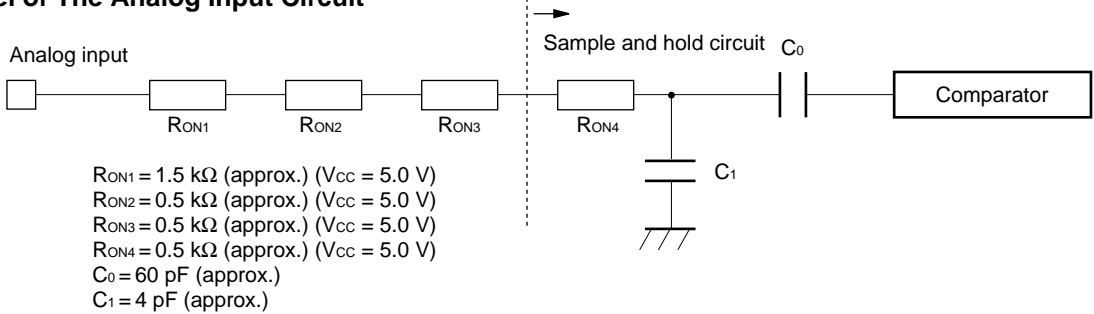

Note: The above values are for reference only.

- $R_{ON1} = 1.5 \text{ k}\Omega$ (approx.) ($V_{CC} = 5.0 \text{ V}$)
- $R_{ON2} = 0.5 \text{ k}\Omega$ (approx.) ($V_{CC} = 5.0 \text{ V}$)
- $R_{ON3} = 0.5 \text{ k}\Omega$ (approx.) ($V_{CC} = 5.0 \text{ V}$)
- $R_{ON4} = 0.5 \text{ k}\Omega$ (approx.) ($V_{CC} = 5.0 \text{ V}$)
- $C_0 = 60 \text{ pF}$ (approx.)
- $C_1 = 4 \text{ pF}$ (approx.)

6. A/D Converter Glossary

- Resolution
The change in analog voltage that can be recognized by the A/D converter.
If the resolution is 10 bits, the analog voltage can be resolved into $2^{10} = 1024$ steps.
- Total error
The deviation between the actual and logic value attributable to offset error, gain error, non-linearity error, and noise.
- Linearity error
The deviation between the actual conversion characteristic of the device and the line linking the zero transition point (00 0000 0000 ↔ 00 0000 0001) and the full scale transition point (11 1111 1110 ↔ 11 1111 1111).
- Differential linearity error
The variation from the ideal input voltage required to change the output code by 1 LSB.

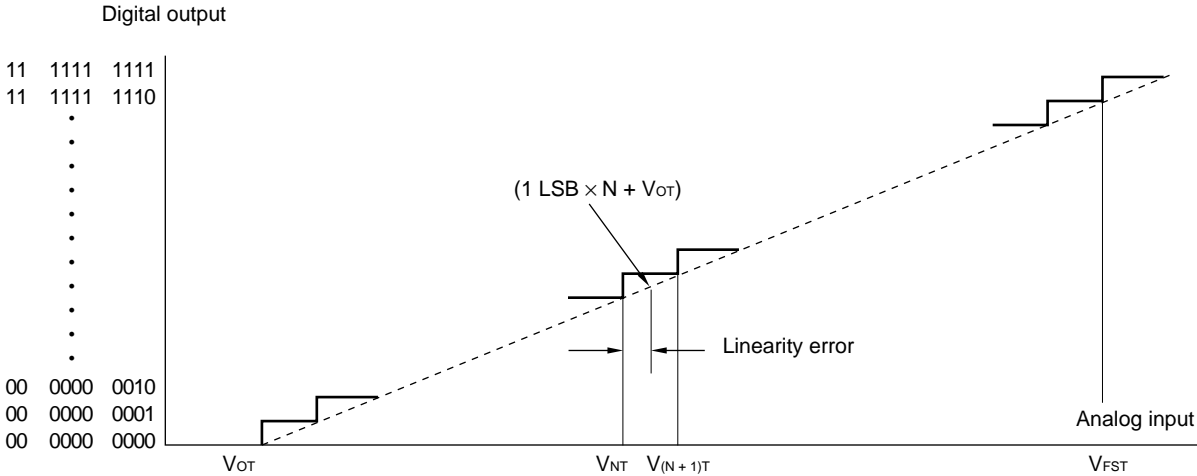

$$1 \text{ LSB} = \frac{V_{FST} - V_{OT}}{1022}$$

$$\text{Linearity error} = \frac{V_{NT} - (1 \text{ LSB} \times N + V_{OT})}{1 \text{ LSB}} \text{ (LSB)}$$

$$\text{Differential linearity error} = \frac{V_{(N+1)T} - V_{NT}}{1 \text{ LSB}} - 1 \text{ (LSB)}$$

MB90610A Series

EXAMPLES CHARACTERISTICS

(1) "H" Level Output Voltage

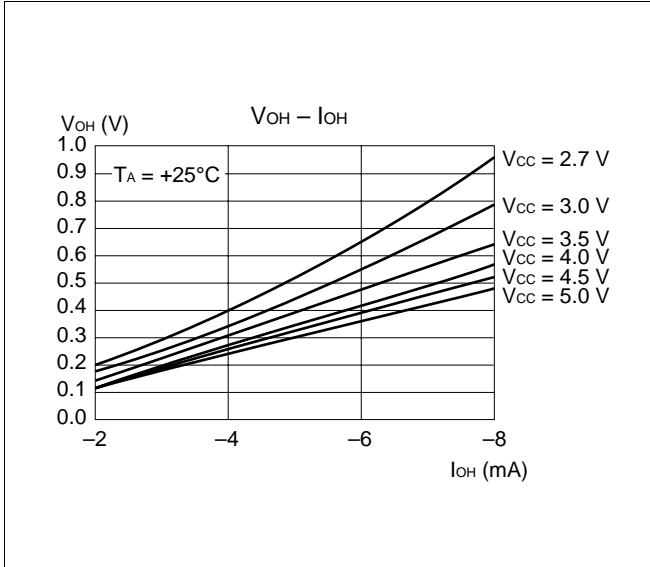

(2) "L" Level Output Voltage

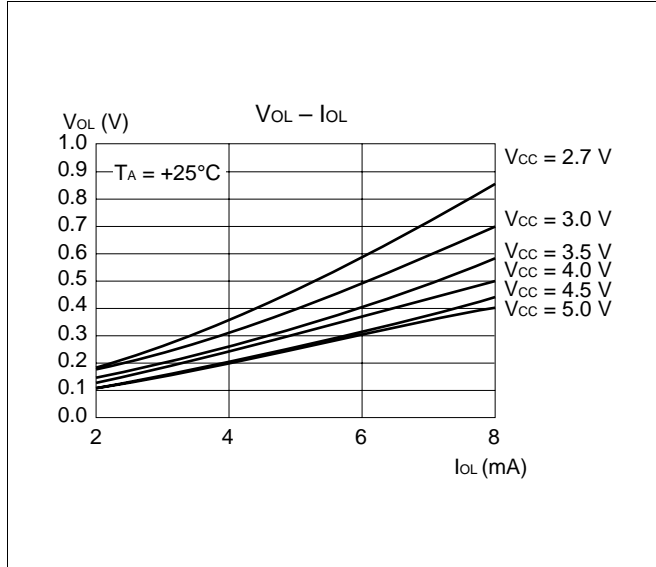

(3) "H" Level Input Voltage/"L" Level Input Voltage

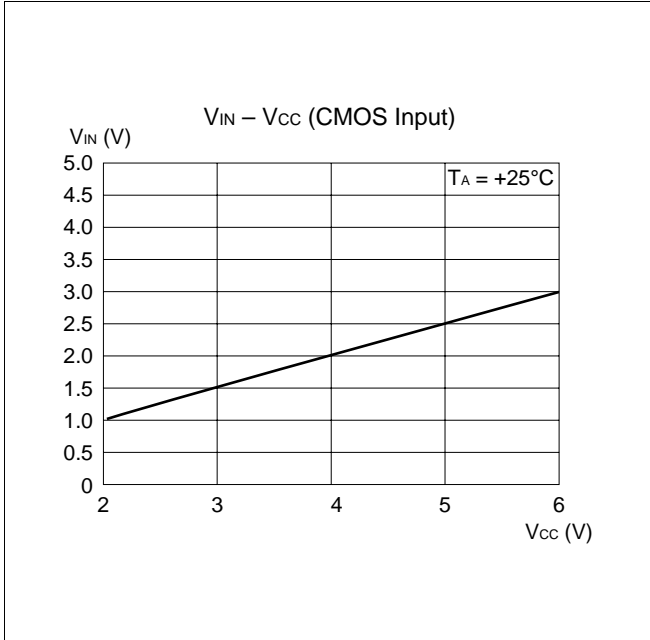

(4) "H" Level Input Voltage/"L" Level Input Voltage

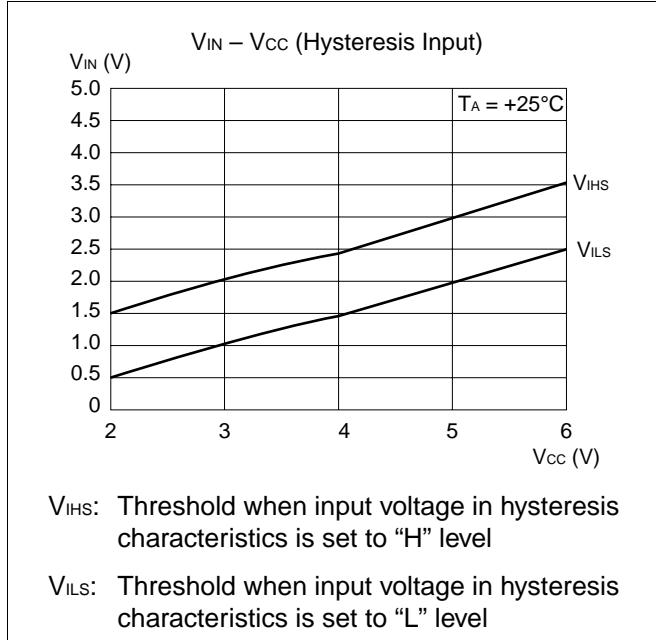

(5) Power Supply Current (f_{cp} = internal frequency)

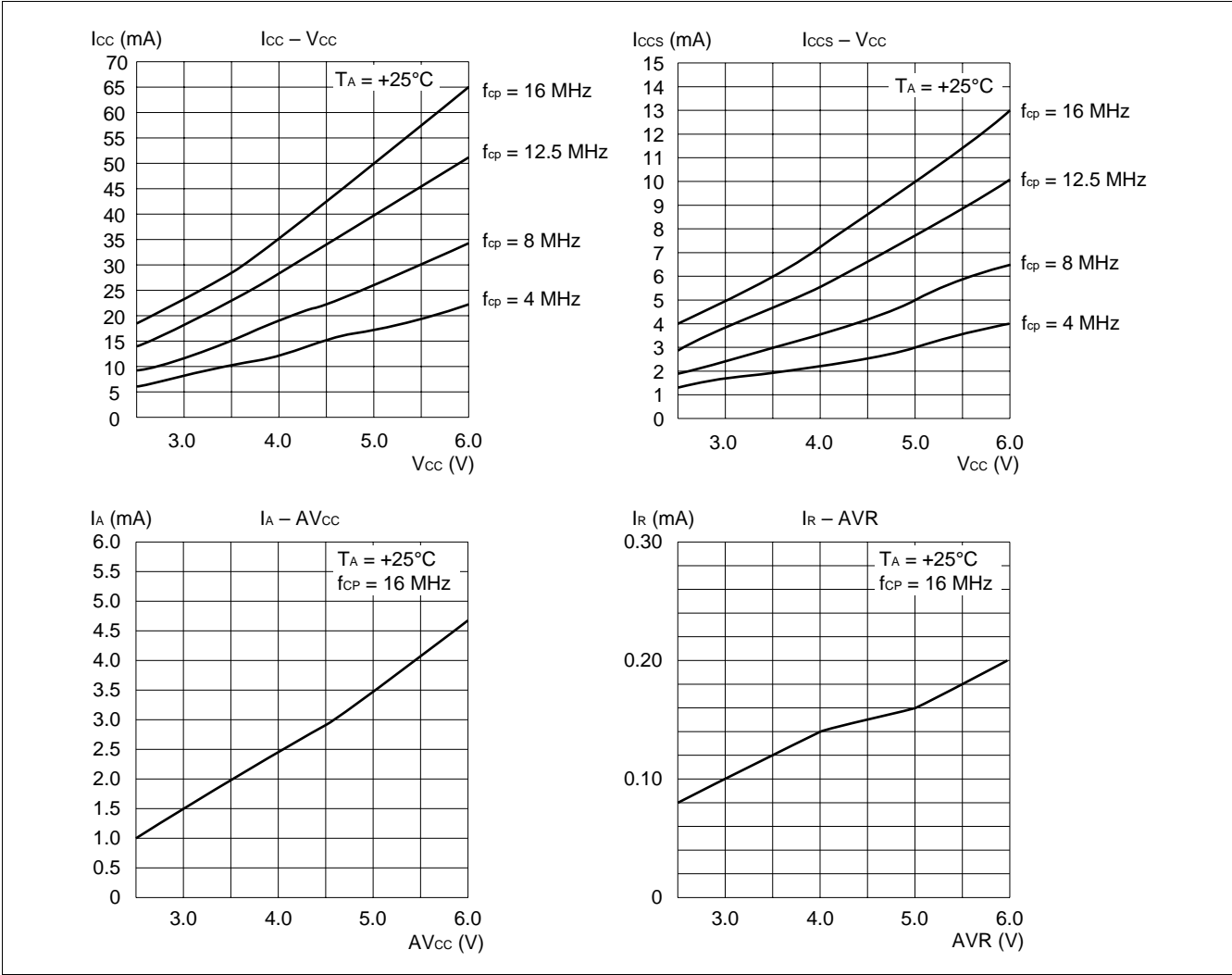

(6) Pull-up Resistance

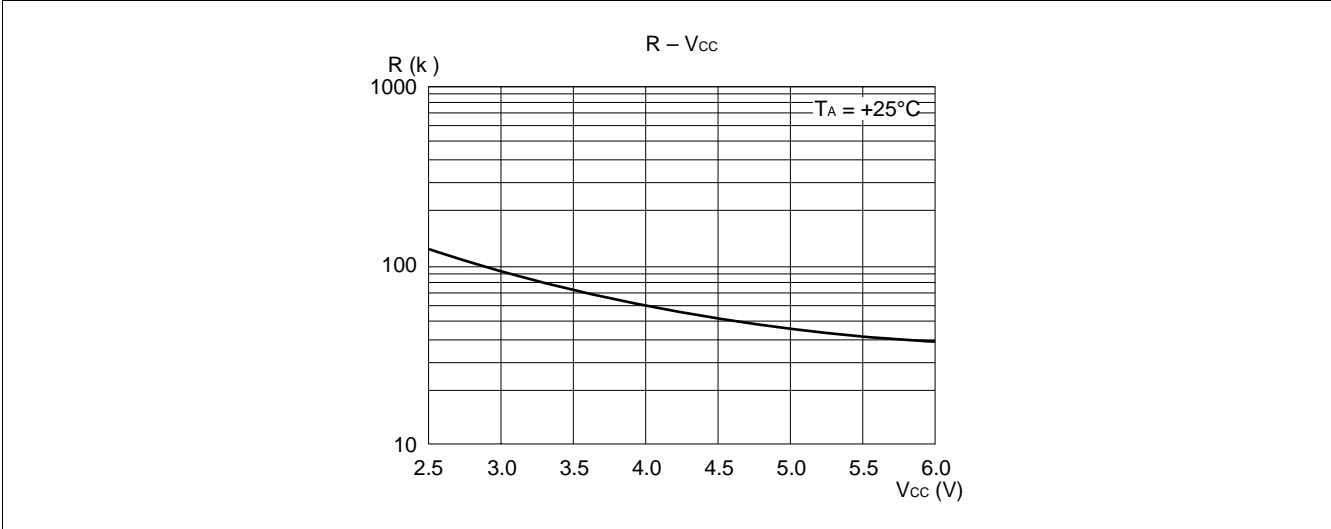

MB90610A Series

■ INSTRUCTIONS (340 INSTRUCTIONS)

Table 1 Explanation of Items in Tables of Instructions

Item	Meaning
Mnemonic	Upper-case letters and symbols: Represented as they appear in assembler. Lower-case letters: Replaced when described in assembler. Numbers after lower-case letters: Indicate the bit width within the instruction.
#	Indicates the number of bytes.
~	Indicates the number of cycles. m : When branching n : When not branching See Table 4 for details about meanings of other letters in items.
RG	Indicates the number of accesses to the register during execution of the instruction. It is used calculate a correction value for intermittent operation of CPU.
B	Indicates the correction value for calculating the number of actual cycles during execution of the instruction. (Table 5) The number of actual cycles during execution of the instruction is the correction value summed with the value in the “~” column.
Operation	Indicates the operation of instruction.
LH	Indicates special operations involving the upper 8 bits of the lower 16 bits of the accumulator. Z : Transfers “0”. X : Extends with a sign before transferring. – : Transfers nothing.
AH	Indicates special operations involving the upper 16 bits in the accumulator. * : Transfers from AL to AH. – : No transfer. Z : Transfers 00 _H to AH. X : Transfers 00 _H or FF _H to AH by signing and extending AL.
I	Indicates the status of each of the following flags: I (interrupt enable), S (stack), T (sticky bit), N (negative), Z (zero), V (overflow), and C (carry). * : Changes due to execution of instruction. – : No change. S : Set by execution of instruction. R : Reset by execution of instruction.
S	
T	
N	
Z	
V	
C	
RMW	Indicates whether the instruction is a read-modify-write instruction. (a single instruction that reads data from memory, etc., processes the data, and then writes the result to memory.) * : Instruction is a read-modify-write instruction. – : Instruction is not a read-modify-write instruction. Note: A read-modify-write instruction cannot be used on addresses that have different meanings depending on whether they are read or written.

Table 2 Explanation of Symbols in Tables of Instructions

Symbol	Meaning
A	32-bit accumulator The bit length varies according to the instruction. Byte : Lower 8 bits of AL Word : 16 bits of AL Long : 32 bits of AL:AH
AH AL	Upper 16 bits of A Lower 16 bits of A
SP	Stack pointer (USP or SSP)
PC	Program counter
PCB	Program bank register
DTB	Data bank register
ADB	Additional data bank register
SSB	System stack bank register
USB	User stack bank register
SPB	Current stack bank register (SSB or USB)
DPR	Direct page register
brg1	DTB, ADB, SSB, USB, DPR, PCB, SPB
brg2	DTB, ADB, SSB, USB, DPR, SPB
Ri	R0, R1, R2, R3, R4, R5, R6, R7
RWi	RW0, RW1, RW2, RW3, RW4, RW5, RW6, RW7
RWj	RW0, RW1, RW2, RW3
RLi	RL0, RL1, RL2, RL3
dir	Compact direct addressing
addr16 addr24 ad24 0 to 15 ad24 16 to 23	Direct addressing Physical direct addressing Bit 0 to bit 15 of addr24 Bit 16 to bit 23 of addr24
io	I/O area (000000H to 0000FFH)
imm4 imm8 imm16 imm32 ext (imm8)	4-bit immediate data 8-bit immediate data 16-bit immediate data 32-bit immediate data 16-bit data signed and extended from 8-bit immediate data
disp8 disp16	8-bit displacement 16-bit displacement
bp	Bit offset
vct4 vct8	Vector number (0 to 15) Vector number (0 to 255)
()b	Bit address

(Continued)

MB90610A Series

(Continued)

Symbol	Meaning
rel	Branch specification relative to PC
ear	Effective addressing (codes 00 to 07)
eam	Effective addressing (codes 08 to 1F)
rlst	Register list

Table 3 Effective Address Fields

Code	Notation			Address format	Number of bytes in address extension *	
00	R0	RW0	RL0	Register direct	—	
01	R1	RW1	(RL0)	“ea” corresponds to byte, word, and long-word types, starting from the left		
02	R2	RW2	RL1			
03	R3	RW3	(RL1)			
04	R4	RW4	RL2			
05	R5	RW5	(RL2)			
06	R6	RW6	RL3			
07	R7	RW7	(RL3)			
08	@RW0				Register indirect	0
09	@RW1			Register indirect with post-increment		
0A	@RW2					
0B	@RW3					
0C	@RW0 +				Register indirect with 8-bit displacement	1
0D	@RW1 +					
0E	@RW2 +					
0F	@RW3 +					
10	@RW0 + disp8			Register indirect with 16-bit displacement	2	
11	@RW1 + disp8					
12	@RW2 + disp8					
13	@RW3 + disp8					
14	@RW4 + disp8					
15	@RW5 + disp8					
16	@RW6 + disp8					
17	@RW7 + disp8					
18	@RW0 + disp16			Register indirect with index	0	
19	@RW1 + disp16					
1A	@RW2 + disp16					
1B	@RW3 + disp16					
1C	@RW0 + RW7			Register indirect with index	0	
1D	@RW1 + RW7			Register indirect with index	0	
1E	@PC + disp16			PC indirect with 16-bit displacement	2	
1F	addr16			Direct address	2	

Note: The number of bytes in the address extension is indicated by the “+” symbol in the “#” (number of bytes) column in the tables of instructions.

Table 4 Number of Execution Cycles for Each Type of Addressing

Code	Operand	(a)	Number of register accesses for each type of addressing
		Number of execution cycles for each type of addressing	
00 to 07	Ri RWi RLi	Listed in tables of instructions	Listed in tables of instructions
08 to 0B	@RWj	2	1
0C to 0F	@RWj +	4	2
10 to 17	@RWi + disp8	2	1
18 to 1B	@RWj + disp16	2	1
1C	@RW0 + RW7	4	2
1D	@RW1 + RW7	4	2
1E	@PC + disp16	2	0
1F	addr16	1	0

Note: “(a)” is used in the “~” (number of states) column and column B (correction value) in the tables of instructions.

Table 5 Correction Values for Number of Cycles Used to Calculate Number of Actual Cycles

Operand	(b) byte		(c) word		(d) long	
	Number of cycles	Number of access	Number of cycles	Number of access	Number of cycles	Number of access
Internal register	+0	1	+0	1	+0	2
Internal memory even address	+0	1	+0	1	+0	2
Internal memory odd address	+0	1	+2	2	+4	4
Even address on external data bus (16 bits)	+1	1	+1	1	+2	2
Odd address on external data bus (16 bits)	+1	1	+4	2	+8	4
External data bus (8 bits)	+1	1	+4	2	+8	4

Notes: • “(b)”, “(c)”, and “(d)” are used in the “~” (number of states) column and column B (correction value) in the tables of instructions.

- When the external data bus is used, it is necessary to add in the number of wait cycles used for ready input and automatic ready.

Table 6 Correction Values for Number of Cycles Used to Calculate Number of Program Fetch Cycles

Instruction	Byte boundary	Word boundary
Internal memory	—	+2
External data bus (16 bits)	—	+3
External data bus (8 bits)	+3	—

Notes: • When the external data bus is used, it is necessary to add in the number of wait cycles used for ready input and automatic ready.

- Because instruction execution is not slowed down by all program fetches in actuality, these correction values should be used for “worst case” calculations.

MB90610A Series

Table 7 Transfer Instructions (Byte) [41 Instructions]

Mnemonic	#	~	RG	B	Operation	LH	AH	I	S	T	N	Z	V	C	RMW
MOV A, dir	2	3	0	(b)	byte (A) ← (dir)	Z	*	-	-	-	*	*	-	-	-
MOV A, addr16	3	4	0	(b)	byte (A) ← (addr16)	Z	*	-	-	-	*	*	-	-	-
MOV A, Ri	1	2	1	0	byte (A) ← (Ri)	Z	*	-	-	-	*	*	-	-	-
MOV A, ear	2	2	1	0	byte (A) ← (ear)	Z	*	-	-	-	*	*	-	-	-
MOV A, eam	2+	3+ (a)	0	(b)	byte (A) ← (eam)	Z	*	-	-	-	*	*	-	-	-
MOV A, io	2	3	0	(b)	byte (A) ← (io)	Z	*	-	-	-	*	*	-	-	-
MOV A, #imm8	2	2	0	0	byte (A) ← imm8	Z	*	-	-	-	*	*	-	-	-
MOV A, @A	2	3	0	(b)	byte (A) ← ((A))	Z	-	-	-	-	*	*	-	-	-
MOV A, @RLi+disp8	3	10	2	(b)	byte (A) ← ((RLi)+disp8)	Z	*	-	-	-	*	*	-	-	-
MOVN A, #imm4	1	1	0	0	byte (A) ← imm4	Z	*	-	-	-	R	*	-	-	-
MOVX A, dir	2	3	0	(b)	byte (A) ← (dir)	X	*	-	-	-	*	*	-	-	-
MOVX A, addr16	3	4	0	(b)	byte (A) ← (addr16)	X	*	-	-	-	*	*	-	-	-
MOVX A, Ri	2	2	1	0	byte (A) ← (Ri)	X	*	-	-	-	*	*	-	-	-
MOVX A, ear	2	2	1	0	byte (A) ← (ear)	X	*	-	-	-	*	*	-	-	-
MOVX A, eam	2+	3+ (a)	0	(b)	byte (A) ← (eam)	X	*	-	-	-	*	*	-	-	-
MOVX A, io	2	3	0	(b)	byte (A) ← (io)	X	*	-	-	-	*	*	-	-	-
MOVX A, #imm8	2	2	0	0	byte (A) ← imm8	X	*	-	-	-	*	*	-	-	-
MOVX A, @A	2	3	0	(b)	byte (A) ← ((A))	X	-	-	-	-	*	*	-	-	-
MOVX A, @RWi+disp8	2	5	1	(b)	byte (A) ← ((RWi)+disp8)	X	*	-	-	-	*	*	-	-	-
MOVX A, @RLi+disp8	3	10	2	(b)	byte (A) ← ((RLi)+disp8)	X	*	-	-	-	*	*	-	-	-
MOV dir, A	2	3	0	(b)	byte (dir) ← (A)	-	-	-	-	-	*	*	-	-	-
MOV addr16, A	3	4	0	(b)	byte (addr16) ← (A)	-	-	-	-	-	*	*	-	-	-
MOV Ri, A	1	2	1	0	byte (Ri) ← (A)	-	-	-	-	-	*	*	-	-	-
MOV ear, A	2	2	1	0	byte (ear) ← (A)	-	-	-	-	-	*	*	-	-	-
MOV eam, A	2+	3+ (a)	0	(b)	byte (eam) ← (A)	-	-	-	-	-	*	*	-	-	-
MOV io, A	2	3	0	(b)	byte (io) ← (A)	-	-	-	-	-	*	*	-	-	-
MOV @RLi+disp8, A	3	10	2	(b)	byte ((RLi) + disp8) ← (A)	-	-	-	-	-	*	*	-	-	-
MOV Ri, ear	2	3	2	0	byte (Ri) ← (ear)	-	-	-	-	-	*	*	-	-	-
MOV Ri, eam	2+	4+ (a)	1	(b)	byte (Ri) ← (eam)	-	-	-	-	-	*	*	-	-	-
MOV ear, Ri	2	4	2	0	byte (ear) ← (Ri)	-	-	-	-	-	*	*	-	-	-
MOV eam, Ri	2+	5+ (a)	1	(b)	byte (eam) ← (Ri)	-	-	-	-	-	*	*	-	-	-
MOV Ri, #imm8	2	2	1	0	byte (Ri) ← imm8	-	-	-	-	-	*	*	-	-	-
MOV io, #imm8	3	5	0	(b)	byte (io) ← imm8	-	-	-	-	-	-	-	-	-	-
MOV dir, #imm8	3	5	0	(b)	byte (dir) ← imm8	-	-	-	-	-	-	-	-	-	-
MOV ear, #imm8	3	2	1	0	byte (ear) ← imm8	-	-	-	-	-	*	*	-	-	-
MOV eam, #imm8	3+	4+ (a)	0	(b)	byte (eam) ← imm8	-	-	-	-	-	*	*	-	-	-
MOV @AL, AH	2	3	0	(b)	byte ((A)) ← (AH)	-	-	-	-	-	*	*	-	-	-
/MOV @A, T															
XCH A, ear	2	4	2	0	byte (A) ↔ (ear)	Z	-	-	-	-	-	-	-	-	-
XCH A, eam	2+	5+ (a)	0	2× (b)	byte (A) ↔ (eam)	Z	-	-	-	-	-	-	-	-	-
XCH Ri, ear	2	7	4	0	byte (Ri) ↔ (ear)	-	-	-	-	-	-	-	-	-	-
XCH Ri, eam	2+	9+ (a)	2	2× (b)	byte (Ri) ↔ (eam)	-	-	-	-	-	-	-	-	-	-

Note: For an explanation of “(a)” to “(d)”, refer to Table 4, “Number of Execution Cycles for Each Type of Addressing,” and Table 5, “Correction Values for Number of Cycles Used to Calculate Number of Actual Cycles.”

Table 8 Transfer Instructions (Word/Long Word) [38 Instructions]

Mnemonic	#	~	RG	B	Operation	LH	AH	I	S	T	N	Z	V	C	RMW
MOVW A, dir	2	3	0	(c)	word (A) ← (dir)	-	*	-	-	-	*	*	-	-	-
MOVW A, addr16	3	4	0	(c)	word (A) ← (addr16)	-	*	-	-	-	*	*	-	-	-
MOVW A, SP	1	1	0	0	word (A) ← (SP)	-	*	-	-	-	*	*	-	-	-
MOVW A, RWi	1	2	1	0	word (A) ← (RWi)	-	*	-	-	-	*	*	-	-	-
MOVW A, ear	2	2	1	0	word (A) ← (ear)	-	*	-	-	-	*	*	-	-	-
MOVW A, eam	2+	3+ (a)	0	(c)	word (A) ← (eam)	-	*	-	-	-	*	*	-	-	-
MOVW A, io	2	3	0	(c)	word (A) ← (io)	-	*	-	-	-	*	*	-	-	-
MOVW A, @A	2	3	0	(c)	word (A) ← ((A))	-	-	-	-	-	*	*	-	-	-
MOVW A, #imm16	3	2	0	0	word (A) ← imm16	-	*	-	-	-	*	*	-	-	-
MOVW A, @RWi+disp8	2	5	1	(c)	word (A) ← ((RWi) +disp8)	-	*	-	-	-	*	*	-	-	-
MOVW A, @RLi+disp8	3	10	2	(c)	word (A) ← ((RLi) +disp8)	-	*	-	-	-	*	*	-	-	-
MOVW dir, A	2	3	0	(c)	word (dir) ← (A)	-	-	-	-	-	*	*	-	-	-
MOVW addr16, A	3	4	0	(c)	word (addr16) ← (A)	-	-	-	-	-	*	*	-	-	-
MOVW SP, A	1	1	0	0	word (SP) ← (A)	-	-	-	-	-	*	*	-	-	-
MOVW RWi, A	1	2	1	0	word (RWi) ← (A)	-	-	-	-	-	*	*	-	-	-
MOVW ear, A	2	2	1	0	word (ear) ← (A)	-	-	-	-	-	*	*	-	-	-
MOVW eam, A	2+	3+ (a)	0	(c)	word (eam) ← (A)	-	-	-	-	-	*	*	-	-	-
MOVW io, A	2	3	0	(c)	word (io) ← (A)	-	-	-	-	-	*	*	-	-	-
MOVW @RWi+disp8, A	2	5	1	(c)	word ((RWi) +disp8) ← (A)	-	-	-	-	-	*	*	-	-	-
MOVW @RLi+disp8, A	3	10	2	(c)	word ((RLi) +disp8) ← (A)	-	-	-	-	-	*	*	-	-	-
MOVW RWi, ear	2	3	2	(0)	word (RWi) ← (ear)	-	-	-	-	-	*	*	-	-	-
MOVW RWi, eam	2+	4+ (a)	1	(c)	word (RWi) ← (eam)	-	-	-	-	-	*	*	-	-	-
MOVW ear, RWi	2	4	2	0	word (ear) ← (RWi)	-	-	-	-	-	*	*	-	-	-
MOVW eam, RWi	2+	5+ (a)	1	(c)	word (eam) ← (RWi)	-	-	-	-	-	*	*	-	-	-
MOVW RWi, #imm16	3	2	1	0	word (RWi) ← imm16	-	-	-	-	-	*	*	-	-	-
MOVW io, #imm16	4	5	0	(c)	word (io) ← imm16	-	-	-	-	-	*	*	-	-	-
MOVW ear, #imm16	4	2	1	0	word (ear) ← imm16	-	-	-	-	-	*	*	-	-	-
MOVW eam, #imm16	4+	4+ (a)	0	(c)	word (eam) ← imm16	-	-	-	-	-	*	*	-	-	-
MOVW AL, AH /MOVW @A, T	2	3	0	(c)	word ((A)) ← (AH)	-	-	-	-	-	*	*	-	-	-
XCHW A, ear	2	4	2	0	word (A) ↔ (ear)	-	-	-	-	-	-	-	-	-	-
XCHW A, eam	2+	5+ (a)	0	2× (c)	word (A) ↔ (eam)	-	-	-	-	-	-	-	-	-	-
XCHW RWi, ear	2	7	4	0	word (RWi) ↔ (ear)	-	-	-	-	-	-	-	-	-	-
XCHW RWi, eam	2+	9+ (a)	2	2× (c)	word (RWi) ↔ (eam)	-	-	-	-	-	-	-	-	-	-
MOVL A, ear	2	4	2	0	long (A) ← (ear)	-	-	-	-	-	*	*	-	-	-
MOVL A, eam	2+	5+ (a)	0	(d)	long (A) ← (eam)	-	-	-	-	-	*	*	-	-	-
MOVL A, #imm32	5	3	0	0	long (A) ← imm32	-	-	-	-	-	*	*	-	-	-
MOVL ear, A	2	4	2	0	long (ear) ← (A)	-	-	-	-	-	*	*	-	-	-
MOVL eam, A	2+	5+ (a)	0	(d)	long (eam) ← (A)	-	-	-	-	-	*	*	-	-	-

Note: For an explanation of “(a)” to “(d)”, refer to Table 4, “Number of Execution Cycles for Each Type of Addressing,” and Table 5, “Correction Values for Number of Cycles Used to Calculate Number of Actual Cycles.”

MB90610A Series

Table 9 Addition and Subtraction Instructions (Byte/Word/Long Word) [42 Instructions]

Mnemonic	#	~	RG	B	Operation	LH	AH	I	S	T	N	Z	V	C	RMW
ADD A, #imm8	2	2	0	0	byte (A) ← (A) +imm8	Z	—	—	—	—	*	*	*	*	—
ADD A, dir	2	5	0	(b)	byte (A) ← (A) +(dir)	Z	—	—	—	—	*	*	*	*	—
ADD A, ear	2	3	1	0	byte (A) ← (A) +(ear)	Z	—	—	—	—	*	*	*	*	—
ADD A, eam	2+	4+(a)	0	(b)	byte (A) ← (A) +(eam)	Z	—	—	—	—	*	*	*	*	—
ADD ear, A	2	3	2	0	byte (ear) ← (ear) + (A)	—	—	—	—	—	*	*	*	*	—
ADD eam, A	2+	5+(a)	0	2×(b)	byte (eam) ← (eam) + (A)	Z	—	—	—	—	*	*	*	*	*
ADDC A	1	2	0	0	byte (A) ← (AH) + (AL) + (C)	Z	—	—	—	—	*	*	*	*	—
ADDC A, ear	2	3	1	0	byte (A) ← (A) + (ear) + (C)	Z	—	—	—	—	*	*	*	*	—
ADDC A, eam	2+	4+(a)	0	(b)	byte (A) ← (A) + (eam) + (C)	Z	—	—	—	—	*	*	*	*	—
ADDDC A	1	3	0	0	byte (A) ← (AH) + (AL) + (C) (decimal)	Z	—	—	—	—	*	*	*	*	—
SUB A, #imm8	2	2	0	0	byte (A) ← (A) -imm8	Z	—	—	—	—	*	*	*	*	—
SUB A, dir	2	5	0	(b)	byte (A) ← (A) - (dir)	Z	—	—	—	—	*	*	*	*	—
SUB A, ear	2	3	1	0	byte (A) ← (A) - (ear)	Z	—	—	—	—	*	*	*	*	—
SUB A, eam	2+	4+(a)	0	(b)	byte (A) ← (A) - (eam)	Z	—	—	—	—	*	*	*	*	—
SUB ear, A	2	3	2	0	byte (ear) ← (ear) - (A)	—	—	—	—	—	*	*	*	*	—
SUB eam, A	2+	5+(a)	0	2×(b)	byte (eam) ← (eam) - (A)	—	—	—	—	—	*	*	*	*	*
SUBC A	1	2	0	0	byte (A) ← (AH) - (AL) - (C)	Z	—	—	—	—	*	*	*	*	—
SUBC A, ear	2	3	1	0	byte (A) ← (A) - (ear) - (C)	Z	—	—	—	—	*	*	*	*	—
SUBC A, eam	2+	4+(a)	0	(b)	byte (A) ← (A) - (eam) - (C)	Z	—	—	—	—	*	*	*	*	—
SUBDC A	1	3	0	0	byte (A) ← (AH) - (AL) - (C) (decimal)	Z	—	—	—	—	*	*	*	*	—
ADDW A	1	2	0	0	word (A) ← (AH) + (AL)	—	—	—	—	—	*	*	*	*	—
ADDW A, ear	2	3	1	0	word (A) ← (A) +(ear)	—	—	—	—	—	*	*	*	*	—
ADDW A, eam	2+	4+(a)	0	(c)	word (A) ← (A) +(eam)	—	—	—	—	—	*	*	*	*	—
ADDW A, #imm16	3	2	0	0	word (A) ← (A) +imm16	—	—	—	—	—	*	*	*	*	—
ADDW ear, A	2	3	2	0	word (ear) ← (ear) + (A)	—	—	—	—	—	*	*	*	*	—
ADDW eam, A	2+	5+(a)	0	2×(c)	word (eam) ← (eam) + (A)	—	—	—	—	—	*	*	*	*	*
ADDCW A, ear	2	3	1	0	word (A) ← (A) + (ear) + (C)	—	—	—	—	—	*	*	*	*	—
ADDCW A, eam	2+	4+(a)	0	(c)	word (A) ← (A) + (eam) + (C)	—	—	—	—	—	*	*	*	*	—
SUBW A	1	2	0	0	word (A) ← (AH) - (AL)	—	—	—	—	—	*	*	*	*	—
SUBW A, ear	2	3	1	0	word (A) ← (A) - (ear)	—	—	—	—	—	*	*	*	*	—
SUBW A, eam	2+	4+(a)	0	(c)	word (A) ← (A) - (eam)	—	—	—	—	—	*	*	*	*	—
SUBW A, #imm16	3	2	0	0	word (A) ← (A) -imm16	—	—	—	—	—	*	*	*	*	—
SUBW ear, A	2	3	2	0	word (ear) ← (ear) - (A)	—	—	—	—	—	*	*	*	*	—
SUBW eam, A	2+	5+(a)	0	2×(c)	word (eam) ← (eam) - (A)	—	—	—	—	—	*	*	*	*	*
SUBCW A, ear	2	3	1	0	word (A) ← (A) - (ear) - (C)	—	—	—	—	—	*	*	*	*	—
SUBCW A, eam	2+	4+(a)	0	(c)	word (A) ← (A) - (eam) - (C)	—	—	—	—	—	*	*	*	*	—
ADDL A, ear	2	6	2	0	long (A) ← (A) + (ear)	—	—	—	—	—	*	*	*	*	—
ADDL A, eam	2+	7+(a)	0	(d)	long (A) ← (A) + (eam)	—	—	—	—	—	*	*	*	*	—
ADDL A, #imm32	5	4	0	0	long (A) ← (A) +imm32	—	—	—	—	—	*	*	*	*	—
SUBL A, ear	2	6	2	0	long (A) ← (A) - (ear)	—	—	—	—	—	*	*	*	*	—
SUBL A, eam	2+	7+(a)	0	(d)	long (A) ← (A) - (eam)	—	—	—	—	—	*	*	*	*	—
SUBL A, #imm32	5	4	0	0	long (A) ← (A) -imm32	—	—	—	—	—	*	*	*	*	—

Note: For an explanation of “(a)” to “(d)”, refer to Table 4, “Number of Execution Cycles for Each Type of Addressing,” and Table 5, “Correction Values for Number of Cycles Used to Calculate Number of Actual Cycles.”

Table 10 Increment and Decrement Instructions (Byte/Word/Long Word) [12 Instructions]

Mnemonic		#	~	RG	B	Operation	LH	AH	I	S	T	N	Z	V	C	RMW
INC	ear	2	2	2	0	byte (ear) ← (ear) +1	-	-	-	-	-	*	*	*	-	-
INC	eam	2+	5+ (a)	0	2× (b)	byte (eam) ← (eam) +1	-	-	-	-	-	*	*	*	-	*
DEC	ear	2	3	2	0	byte (ear) ← (ear) -1	-	-	-	-	-	*	*	*	-	-
DEC	eam	2+	5+ (a)	0	2× (b)	byte (eam) ← (eam) -1	-	-	-	-	-	*	*	*	-	*
INCW	ear	2	3	2	0	word (ear) ← (ear) +1	-	-	-	-	-	*	*	*	-	-
INCW	eam	2+	5+ (a)	0	2× (c)	word (eam) ← (eam) +1	-	-	-	-	-	*	*	*	-	*
DECW	ear	2	3	2	0	word (ear) ← (ear) -1	-	-	-	-	-	*	*	*	-	-
DECW	eam	2+	5+ (a)	0	2× (c)	word (eam) ← (eam) -1	-	-	-	-	-	*	*	*	-	*
INCL	ear	2	7	4	0	long (ear) ← (ear) +1	-	-	-	-	-	*	*	*	-	-
INCL	eam	2+	9+ (a)	0	2× (d)	long (eam) ← (eam) +1	-	-	-	-	-	*	*	*	-	*
DECL	ear	2	7	4	0	long (ear) ← (ear) -1	-	-	-	-	-	*	*	*	-	-
DECL	eam	2+	9+ (a)	0	2× (d)	long (eam) ← (eam) -1	-	-	-	-	-	*	*	*	-	*

Note: For an explanation of “(a)” to “(d)”, refer to Table 4, “Number of Execution Cycles for Each Type of Addressing,” and Table 5, “Correction Values for Number of Cycles Used to Calculate Number of Actual Cycles.”

Table 11 Compare Instructions (Byte/Word/Long Word) [11 Instructions]

Mnemonic		#	~	RG	B	Operation	LH	AH	I	S	T	N	Z	V	C	RMW
CMP	A	1	1	0	0	byte (AH) - (AL)	-	-	-	-	-	*	*	*	*	-
CMP	A, ear	2	2	1	0	byte (A) ← (ear)	-	-	-	-	-	*	*	*	*	-
CMP	A, eam	2+	3+ (a)	0	(b)	byte (A) ← (eam)	-	-	-	-	-	*	*	*	*	-
CMP	A, #imm8	2	2	0	0	byte (A) ← imm8	-	-	-	-	-	*	*	*	*	-
CMPW	A	1	1	0	0	word (AH) - (AL)	-	-	-	-	-	*	*	*	*	-
CMPW	A, ear	2	2	1	0	word (A) ← (ear)	-	-	-	-	-	*	*	*	*	-
CMPW	A, eam	2+	3+ (a)	0	(c)	word (A) ← (eam)	-	-	-	-	-	*	*	*	*	-
CMPW	A, #imm16	3	2	0	0	word (A) ← imm16	-	-	-	-	-	*	*	*	*	-
CMPL	A, ear	2	6	2	0	word (A) ← (ear)	-	-	-	-	-	*	*	*	*	-
CMPL	A, eam	2+	7+ (a)	0	(d)	word (A) ← (eam)	-	-	-	-	-	*	*	*	*	-
CMPL	A, #imm32	5	3	0	0	word (A) ← imm32	-	-	-	-	-	*	*	*	*	-

Note: For an explanation of “(a)” to “(d)”, refer to Table 4, “Number of Execution Cycles for Each Type of Addressing,” and Table 5, “Correction Values for Number of Cycles Used to Calculate Number of Actual Cycles.”

MB90610A Series

Table 12 Multiplication and Division Instructions (Byte/Word/Long Word) [11 Instructions]

Mnemonic	#	~	RG	B	Operation	LH	AH	I	S	T	N	Z	V	C	RMW
DIVU A	1	*1	0	0	word (AH) /byte (AL) Quotient → byte (AL) Remainder → byte (AH)	-	-	-	-	-	-	-	*	*	-
DIVU A, ear	2	*2	1	0	word (A)/byte (ear) Quotient → byte (A) Remainder → byte (ear)	-	-	-	-	-	-	-	*	*	-
DIVU A, eam	2+	*3	0	*6	word (A)/byte (eam) Quotient → byte (A) Remainder → byte (eam)	-	-	-	-	-	-	-	*	*	-
DIVUW A, ear	2	*4	1	0	long (A)/word (ear) Quotient → word (A) Remainder → word (ear)	-	-	-	-	-	-	-	*	*	-
DIVUW A, eam	2+	*5	0	*7	long (A)/word (eam) Quotient → word (A) Remainder → word (eam)	-	-	-	-	-	-	-	*	*	-
MULU A	1	*8	0	0	byte (AH) *byte (AL) → word (A)	-	-	-	-	-	-	-	-	-	-
MULU A, ear	2	*9	1	0	byte (A) *byte (ear) → word (A)	-	-	-	-	-	-	-	-	-	-
MULU A, eam	2+	*10	0	(b)	byte (A) *byte (eam) → word (A)	-	-	-	-	-	-	-	-	-	-
MULUW A	1	*11	0	0	word (AH) *word (AL) → long (A)	-	-	-	-	-	-	-	-	-	-
MULUW A, ear	2	*12	1	0	word (A) *word (ear) → long (A)	-	-	-	-	-	-	-	-	-	-
MULUW A, eam	2+	*13	0	(c)	word (A) *word (eam) → long (A)	-	-	-	-	-	-	-	-	-	-

- *1: 3 when the result is zero, 7 when an overflow occurs, and 15 normally.
- *2: 4 when the result is zero, 8 when an overflow occurs, and 16 normally.
- *3: 6 + (a) when the result is zero, 9 + (a) when an overflow occurs, and 19 + (a) normally.
- *4: 4 when the result is zero, 7 when an overflow occurs, and 22 normally.
- *5: 6 + (a) when the result is zero, 8 + (a) when an overflow occurs, and 26 + (a) normally.
- *6: (b) when the result is zero or when an overflow occurs, and 2 × (b) normally.
- *7: (c) when the result is zero or when an overflow occurs, and 2 × (c) normally.
- *8: 3 when byte (AH) is zero, and 7 when byte (AH) is not zero.
- *9: 4 when byte (ear) is zero, and 8 when byte (ear) is not zero.
- *10: 5 + (a) when byte (eam) is zero, and 9 + (a) when byte (eam) is not 0.
- *11: 3 when word (AH) is zero, and 11 when word (AH) is not zero.
- *12: 4 when word (ear) is zero, and 12 when word (ear) is not zero.
- *13: 5 + (a) when word (eam) is zero, and 13 + (a) when word (eam) is not zero.

Note: For an explanation of “(a)” to “(d)”, refer to Table 4, “Number of Execution Cycles for Each Type of Addressing,” and Table 5, “Correction Values for Number of Cycles Used to Calculate Number of Actual Cycles.”

Table 13 Logical 1 Instructions (Byte/Word) [39 Instructions]

Mnemonic	#	~	RG	B	Operation	LH	AH	I	S	T	N	Z	V	C	RMW
AND A, #imm8	2	2	0	0	byte (A) ← (A) and imm8	-	-	-	-	-	*	*	R	-	-
AND A, ear	2	3	1	0	byte (A) ← (A) and (ear)	-	-	-	-	-	*	*	R	-	-
AND A, eam	2+	4+ (a)	0	(b)	byte (A) ← (A) and (eam)	-	-	-	-	-	*	*	R	-	-
AND ear, A	2	3	2	0	byte (ear) ← (ear) and (A)	-	-	-	-	-	*	*	R	-	-
AND eam, A	2+	5+ (a)	0	2× (b)	byte (eam) ← (eam) and (A)	-	-	-	-	-	*	*	R	-	*
OR A, #imm8	2	2	0	0	byte (A) ← (A) or imm8	-	-	-	-	-	*	*	R	-	-
OR A, ear	2	3	1	0	byte (A) ← (A) or (ear)	-	-	-	-	-	*	*	R	-	-
OR A, eam	2+	4+ (a)	0	(b)	byte (A) ← (A) or (eam)	-	-	-	-	-	*	*	R	-	-
OR ear, A	2	3	2	0	byte (ear) ← (ear) or (A)	-	-	-	-	-	*	*	R	-	-
OR eam, A	2+	5+ (a)	0	2× (b)	byte (eam) ← (eam) or (A)	-	-	-	-	-	*	*	R	-	*
XOR A, #imm8	2	2	0	0	byte (A) ← (A) xor imm8	-	-	-	-	-	*	*	R	-	-
XOR A, ear	2	3	1	0	byte (A) ← (A) xor (ear)	-	-	-	-	-	*	*	R	-	-
XOR A, eam	2+	4+ (a)	0	(b)	byte (A) ← (A) xor (eam)	-	-	-	-	-	*	*	R	-	-
XOR ear, A	2	3	2	0	byte (ear) ← (ear) xor (A)	-	-	-	-	-	*	*	R	-	-
XOR eam, A	2+	5+ (a)	0	2× (b)	byte (eam) ← (eam) xor (A)	-	-	-	-	-	*	*	R	-	*
NOT A	1	2	0	0	byte (A) ← not (A)	-	-	-	-	-	*	*	R	-	-
NOT ear	2	3	2	0	byte (ear) ← not (ear)	-	-	-	-	-	*	*	R	-	-
NOT eam	2+	5+ (a)	0	2× (b)	byte (eam) ← not (eam)	-	-	-	-	-	*	*	R	-	*
ANDW A	1	2	0	0	word (A) ← (AH) and (A)	-	-	-	-	-	*	*	R	-	-
ANDW A, #imm16	3	2	0	0	word (A) ← (A) and imm16	-	-	-	-	-	*	*	R	-	-
ANDW A, ear	2	3	1	0	word (A) ← (A) and (ear)	-	-	-	-	-	*	*	R	-	-
ANDW A, eam	2+	4+ (a)	0	(c)	word (A) ← (A) and (eam)	-	-	-	-	-	*	*	R	-	-
ANDW ear, A	2	3	2	0	word (ear) ← (ear) and (A)	-	-	-	-	-	*	*	R	-	-
ANDW eam, A	2+	5+ (a)	0	2× (c)	word (eam) ← (eam) and (A)	-	-	-	-	-	*	*	R	-	*
ORW A	1	2	0	0	word (A) ← (AH) or (A)	-	-	-	-	-	*	*	R	-	-
ORW A, #imm16	3	2	0	0	word (A) ← (A) or imm16	-	-	-	-	-	*	*	R	-	-
ORW A, ear	2	3	1	0	word (A) ← (A) or (ear)	-	-	-	-	-	*	*	R	-	-
ORW A, eam	2+	4+ (a)	0	(c)	word (A) ← (A) or (eam)	-	-	-	-	-	*	*	R	-	-
ORW ear, A	2	3	2	0	word (ear) ← (ear) or (A)	-	-	-	-	-	*	*	R	-	-
ORW eam, A	2+	5+ (a)	0	2× (c)	word (eam) ← (eam) or (A)	-	-	-	-	-	*	*	R	-	*
XORW A	1	2	0	0	word (A) ← (AH) xor (A)	-	-	-	-	-	*	*	R	-	-
XORW A, #imm16	3	2	0	0	word (A) ← (A) xor imm16	-	-	-	-	-	*	*	R	-	-
XORW A, ear	2	3	1	0	word (A) ← (A) xor (ear)	-	-	-	-	-	*	*	R	-	-
XORW A, eam	2+	4+ (a)	0	(c)	word (A) ← (A) xor (eam)	-	-	-	-	-	*	*	R	-	-
XORW ear, A	2	3	2	0	word (ear) ← (ear) xor (A)	-	-	-	-	-	*	*	R	-	-
XORW eam, A	2+	5+ (a)	0	2× (c)	word (eam) ← (eam) xor (A)	-	-	-	-	-	*	*	R	-	*
NOTW A	1	2	0	0	word (A) ← not (A)	-	-	-	-	-	*	*	R	-	-
NOTW ear	2	3	2	0	word (ear) ← not (ear)	-	-	-	-	-	*	*	R	-	-
NOTW eam	2+	5+ (a)	0	2× (c)	word (eam) ← not (eam)	-	-	-	-	-	*	*	R	-	*

Note: For an explanation of “(a)” to “(d)”, refer to Table 4, “Number of Execution Cycles for Each Type of Addressing,” and Table 5, “Correction Values for Number of Cycles Used to Calculate Number of Actual Cycles.”

MB90610A Series

Table 14 Logical 2 Instructions (Long Word) [6 Instructions]

Mnemonic	#	~	RG	B	Operation	LH	AH	I	S	T	N	Z	V	C	RMW
ANDL A, ear	2	6	2	0	long (A) ← (A) and (ear)	-	-	-	-	-	*	*	R	-	-
ANDL A, eam	2+	7+ (a)	0	(d)	long (A) ← (A) and (eam)	-	-	-	-	-	*	*	R	-	-
ORL A, ear	2	6	2	0	long (A) ← (A) or (ear)	-	-	-	-	-	*	*	R	-	-
ORL A, eam	2+	7+ (a)	0	(d)	long (A) ← (A) or (eam)	-	-	-	-	-	*	*	R	-	-
XORL A, ea	2	6	2	0	long (A) ← (A) xor (ear)	-	-	-	-	-	*	*	R	-	-
XORL A, eam	2+	7+ (a)	0	(d)	long (A) ← (A) xor (eam)	-	-	-	-	-	*	*	R	-	-

Table 15 Sign Inversion Instructions (Byte/Word) [6 Instructions]

Mnemonic	#	~	RG	B	Operation	LH	AH	I	S	T	N	Z	V	C	RMW
NEG A	1	2	0	0	byte (A) ← 0 - (A)	X	-	-	-	-	*	*	*	*	-
NEG ear	2	3	2	0	byte (ear) ← 0 - (ear)	-	-	-	-	-	*	*	*	*	-
NEG eam	2+	5+ (a)	0	2×(b)	byte (eam) ← 0 - (eam)	-	-	-	-	-	*	*	*	*	*
NEGW A	1	2	0	0	word (A) ← 0 - (A)	-	-	-	-	-	*	*	*	*	-
NEGW ear	2	3	2	0	word (ear) ← 0 - (ear)	-	-	-	-	-	*	*	*	*	-
NEGW eam	2+	5+ (a)	0	2×(c)	word (eam) ← 0 - (eam)	-	-	-	-	-	*	*	*	*	*

Table 16 Normalize Instruction (Long Word) [1 Instruction]

Mnemonic	#	~	RG	B	Operation	LH	AH	I	S	T	N	Z	V	C	RMW
NRML A, R0	2	*1	1	0	long (A) ← Shift until first digit is "1" byte (R0) ← Current shift count	-	-	-	-	-	-	*	-	-	-

*1: 4 when the contents of the accumulator are all zeroes, 6 + (R0) in all other cases (shift count).

Note: For an explanation of "(a)" to "(d)", refer to Table 4, "Number of Execution Cycles for Each Type of Addressing," and Table 5, "Correction Values for Number of Cycles Used to Calculate Number of Actual Cycles."

Table 17 Shift Instructions (Byte/Word/Long Word) [18 Instructions]

Mnemonic	#	~	RG	B	Operation	LH	AH	I	S	T	N	Z	V	C	RMW
RORC A	2	2	0	0	byte (A) ← Right rotation with carry	-	-	-	-	-	*	*	-	*	-
ROLC A	2	2	0	0	byte (A) ← Left rotation with carry	-	-	-	-	-	*	*	-	*	-
RORC ear	2	3	2	0	byte (ear) ← Right rotation with carry	-	-	-	-	-	*	*	-	*	-
RORC eam	2+	5+(a)	0	2×(b)	byte (eam) ← Right rotation with carry	-	-	-	-	-	*	*	-	*	*
ROLC ear	2	3	2	0	byte (ear) ← Left rotation with carry	-	-	-	-	-	*	*	-	*	-
ROLC eam	2+	5+(a)	0	2×(b)	byte (eam) ← Left rotation with carry	-	-	-	-	-	*	*	-	*	*
ASR A, R0	2	*1	1	0	byte (A) ← Arithmetic right barrel shift (A, R0)	-	-	-	-	*	*	*	-	*	-
LSR A, R0	2	*1	1	0	byte (A) ← Logical right barrel shift (A, R0)	-	-	-	-	*	*	*	-	*	-
LSL A, R0	2	*1	1	0	byte (A) ← Logical left barrel shift (A, R0)	-	-	-	-	-	*	*	-	*	-
ASRW A	1	2	0	0	word (A) ← Arithmetic right shift (A, 1 bit)	-	-	-	-	*	*	*	-	*	-
LSRW A/SHRW A	1	2	0	0	word (A) ← Logical right shift (A, 1 bit)	-	-	-	-	*	R	*	-	*	-
LSLW A/SHLW A	1	2	0	0	word (A) ← Logical left shift (A, 1 bit)	-	-	-	-	-	*	*	-	*	-
ASRW A, R0	2	*1	1	0	word (A) ← Arithmetic right barrel shift (A, R0)	-	-	-	-	*	*	*	-	*	-
LSRW A, R0	2	*1	1	0	word (A) ← Logical right barrel shift (A, R0)	-	-	-	-	*	*	*	-	*	-
LSLW A, R0	2	*1	1	0	word (A) ← Logical left barrel shift (A, R0)	-	-	-	-	-	*	*	-	*	-
ASRL A, R0	2	*2	1	0	long (A) ← Arithmetic right shift (A, R0)	-	-	-	-	*	*	*	-	*	-
LSRL A, R0	2	*2	1	0	long (A) ← Logical right barrel shift (A, R0)	-	-	-	-	*	*	*	-	*	-
LSLL A, R0	2	*2	1	0	long (A) ← Logical left barrel shift (A, R0)	-	-	-	-	-	*	*	-	*	-

*1: 6 when R0 is 0, 5 + (R0) in all other cases.

*2: 6 when R0 is 0, 6 + (R0) in all other cases.

Note: For an explanation of “(a)” to “(d)”, refer to Table 4, “Number of Execution Cycles for Each Type of Addressing,” and Table 5, “Correction Values for Number of Cycles Used to Calculate Number of Actual Cycles.”

MB90610A Series

Table 18 Branch 1 Instructions [31 Instructions]

Mnemonic	#	~	RG	B	Operation	LH	AH	I	S	T	N	Z	V	C	RMW
BZ/BEQ rel	2	*1	0	0	Branch when (Z) = 1	-	-	-	-	-	-	-	-	-	-
BNZ/BNE rel	2	*1	0	0	Branch when (Z) = 0	-	-	-	-	-	-	-	-	-	-
BC/BLO rel	2	*1	0	0	Branch when (C) = 1	-	-	-	-	-	-	-	-	-	-
BNC/BHS rel	2	*1	0	0	Branch when (C) = 0	-	-	-	-	-	-	-	-	-	-
BN rel	2	*1	0	0	Branch when (N) = 1	-	-	-	-	-	-	-	-	-	-
BP rel	2	*1	0	0	Branch when (N) = 0	-	-	-	-	-	-	-	-	-	-
BV rel	2	*1	0	0	Branch when (V) = 1	-	-	-	-	-	-	-	-	-	-
BNV rel	2	*1	0	0	Branch when (V) = 0	-	-	-	-	-	-	-	-	-	-
BT rel	2	*1	0	0	Branch when (T) = 1	-	-	-	-	-	-	-	-	-	-
BNT rel	2	*1	0	0	Branch when (T) = 0	-	-	-	-	-	-	-	-	-	-
BLT rel	2	*1	0	0	Branch when (V) xor (N) = 1	-	-	-	-	-	-	-	-	-	-
BGE rel	2	*1	0	0	Branch when (V) xor (N) = 0	-	-	-	-	-	-	-	-	-	-
BLE rel	2	*1	0	0	Branch when ((V) xor (N)) or (Z) = 1	-	-	-	-	-	-	-	-	-	-
BGT rel	2	*1	0	0	Branch when ((V) xor (N)) or (Z) = 0	-	-	-	-	-	-	-	-	-	-
BLS rel	2	*1	0	0	Branch when (C) or (Z) = 1	-	-	-	-	-	-	-	-	-	-
BHI rel	2	*1	0	0	Branch when (C) or (Z) = 0	-	-	-	-	-	-	-	-	-	-
BRA rel	2	*1	0	0	Branch unconditionally	-	-	-	-	-	-	-	-	-	-
JMP @A	1		0	0	word (PC) ← (A)	-	-	-	-	-	-	-	-	-	-
JMP addr16	3	2	0	0	word (PC) ← addr16	-	-	-	-	-	-	-	-	-	-
JMP @ear	2	3	1	0	word (PC) ← (ear)	-	-	-	-	-	-	-	-	-	-
JMP @eam	2+	3	0	(c)	word (PC) ← (eam)	-	-	-	-	-	-	-	-	-	-
JMPP @ear *3	2	4+(a)	2	0	word (PC) ← (ear), (PCB) ← (ear +2)	-	-	-	-	-	-	-	-	-	-
JMPP @eam *3	2+	5	0	(d)	word (PC) ← (eam), (PCB) ← (eam +2)	-	-	-	-	-	-	-	-	-	-
JMPP addr24	4	6+(a)	0	0	word (PC) ← ad24 0 to 15, (PCB) ← ad24 16 to 23	-	-	-	-	-	-	-	-	-	-
CALL @ear *4	2	6	1	(c)	word (PC) ← (ear)	-	-	-	-	-	-	-	-	-	-
CALL @eam *4	2+	6	0	2×(c)	word (PC) ← (eam)	-	-	-	-	-	-	-	-	-	-
CALL addr16 *5	3	7+(a)	0	(c)	word (PC) ← addr16	-	-	-	-	-	-	-	-	-	-
CALLV #vct4 *5	1	6	0	2×(c)	Vector call instruction	-	-	-	-	-	-	-	-	-	-
CALLP @ear *6	2	7	2	2×(c)	word (PC) ← (ear) 0 to 15 (PCB) ← (ear) 16 to 23	-	-	-	-	-	-	-	-	-	-
CALLP @eam *6	2+	10	0	*2	word (PC) ← (eam) 0 to 15 (PCB) ← (eam) 16 to 23	-	-	-	-	-	-	-	-	-	-
CALLP addr24 *7	4	11+(a)	0	2×(c)	word (PC) ← addr0 to 15, (PCB) ← addr16 to 23	-	-	-	-	-	-	-	-	-	-

*1: 4 when branching, 3 when not branching.

*2: (b) + 3 × (c)

*3: Read (word) branch address.

*4: W: Save (word) to stack; R: read (word) branch address.

*5: Save (word) to stack.

*6: W: Save (long word) to W stack; R: read (long word) R branch address.

*7: Save (long word) to stack.

Note: For an explanation of "(a)" to "(d)", refer to Table 4, "Number of Execution Cycles for Each Type of Addressing," and Table 5, "Correction Values for Number of Cycles Used to Calculate Number of Actual Cycles."

Table 19 Branch 2 Instructions [19 Instructions]

Mnemonic	#	~	RG	B	Operation	LH	AH	I	S	T	N	Z	V	C	RMW
CBNE A, #imm8, rel	3	*1	0	0	Branch when byte (A) ≠ imm8	–	–	–	–	–	*	*	*	*	–
CWBNE A, #imm16, rel	4	*1	0	0	Branch when word (A) ≠ imm16	–	–	–	–	–	*	*	*	*	–
CBNE ear, #imm8, rel	4	*2	1	0	Branch when byte (ear) ≠ imm8	–	–	–	–	–	*	*	*	*	–
CBNE eam, #imm8, rel*9	4+	*3	0	(b)	Branch when byte (eam) ≠ imm8	–	–	–	–	–	*	*	*	*	–
CWBNE ear, #imm16, rel	5	*4	1	0	Branch when word (ear) ≠ imm16	–	–	–	–	–	*	*	*	*	–
CWBNE eam, #imm16, rel*9	5+	*3	0	(c)	Branch when word (eam) ≠ imm16	–	–	–	–	–	*	*	*	*	–
DBNZ ear, rel	3	*5	2	0	Branch when byte (ear) = (ear) – 1, and (ear) ≠ 0	–	–	–	–	–	*	*	*	–	–
DBNZ eam, rel	3+	*6	2	2×(b)	Branch when byte (eam) = (eam) – 1, and (eam) ≠ 0	–	–	–	–	–	*	*	*	–	*
DWBNZ ear, rel	3	*5	2	0	Branch when word (ear) = (ear) – 1, and (ear) ≠ 0	–	–	–	–	–	*	*	*	–	–
DWBNZ eam, rel	3+	*6	2	2×(c)	Branch when word (eam) = (eam) – 1, and (eam) ≠ 0	–	–	–	–	–	*	*	*	–	*
INT #vct8	2	20	0	8×(c)	Software interrupt	–	–	R	S	–	–	–	–	–	–
INT addr16	3	16	0	6×(c)	Software interrupt	–	–	R	S	–	–	–	–	–	–
INTP addr24	4	17	0	6×(c)	Software interrupt	–	–	R	S	–	–	–	–	–	–
INT9	1	20	0	8×(c)	Software interrupt	–	–	R	S	–	–	–	–	–	–
RETI	1	15	0	6×(c)	Return from interrupt	–	–	*	*	*	*	*	*	*	–
LINK #local8	2	6	0	(c)	At constant entry, save old frame pointer to stack, set new frame pointer, and allocate local pointer area	–	–	–	–	–	–	–	–	–	–
UNLINK	1	5	0	(c)	At constant entry, retrieve old frame pointer from stack.	–	–	–	–	–	–	–	–	–	–
RET *7	1	4	0	(c)	Return from subroutine	–	–	–	–	–	–	–	–	–	–
RETP *8	1	6	0	(d)	Return from subroutine	–	–	–	–	–	–	–	–	–	–

- *1: 5 when branching, 4 when not branching
- *2: 13 when branching, 12 when not branching
- *3: 7 + (a) when branching, 6 + (a) when not branching
- *4: 8 when branching, 7 when not branching
- *5: 7 when branching, 6 when not branching
- *6: 8 + (a) when branching, 7 + (a) when not branching
- *7: Retrieve (word) from stack
- *8: Retrieve (long word) from stack
- *9: In the CBNE/CWBNE instruction, do not use the RWj+ addressing mode.

Note: For an explanation of “(a)” to “(d)”, refer to Table 4, “Number of Execution Cycles for Each Type of Addressing,” and Table 5, “Correction Values for Number of Cycles Used to Calculate Number of Actual Cycles.”

MB90610A Series

Table 20 Other Control Instructions (Byte/Word/Long Word) [36 Instructions]

Mnemonic	#	~	RG	B	Operation	LH	AH	I	S	T	N	Z	V	C	RMW
PUSHW A	1	4	0	(c)	word (SP) ← (SP) -2, ((SP)) ← (A)	-	-	-	-	-	-	-	-	-	-
PUSHW AH	1	4	0	(c)	word (SP) ← (SP) -2, ((SP)) ← (AH)	-	-	-	-	-	-	-	-	-	-
PUSHW PS	1	4	0	(c)	word (SP) ← (SP) -2, ((SP)) ← (PS)	-	-	-	-	-	-	-	-	-	-
PUSHW rlst	2	*3	*5	*4	(SP) ← (SP) -2n, ((SP)) ← (rlst)	-	-	-	-	-	-	-	-	-	-
POPW A	1	3	0	(c)	word (A) ← ((SP)), (SP) ← (SP) +2	-	*	-	-	-	-	-	-	-	-
POPW AH	1	3	0	(c)	word (AH) ← ((SP)), (SP) ← (SP) +2	-	-	-	-	-	-	-	-	-	-
POPW PS	1	4	0	(c)	word (PS) ← ((SP)), (SP) ← (SP) +2	-	-	*	*	*	*	*	*	*	-
POPW rlst	2	*2	*5	*4	(rlst) ← ((SP)), (SP) ← (SP) +2n	-	-	-	-	-	-	-	-	-	-
JCTX @A	1	14	0	6× (c)	Context switch instruction	-	-	*	*	*	*	*	*	*	-
AND CCR, #imm8	2	3	0	0	byte (CCR) ← (CCR) and imm8	-	-	*	*	*	*	*	*	*	-
OR CCR, #imm8	2	3	0	0	byte (CCR) ← (CCR) or imm8	-	-	*	*	*	*	*	*	*	-
MOV RP, #imm8	2	2	0	0	byte (RP) ← imm8	-	-	-	-	-	-	-	-	-	-
MOV ILM, #imm8	2	2	0	0	byte (ILM) ← imm8	-	-	-	-	-	-	-	-	-	-
MOVEA RWi, ear	2	3	1	0	word (RWi) ← ear	-	-	-	-	-	-	-	-	-	-
MOVEA RWi, eam	2+	2+ (a)	1	0	word (RWi) ← eam	-	-	-	-	-	-	-	-	-	-
MOVEA A, ear	2	1	0	0	word (A) ← ear	-	*	-	-	-	-	-	-	-	-
MOVEA A, eam	2+	1+ (a)	0	0	word (A) ← eam	-	*	-	-	-	-	-	-	-	-
ADDSP #imm8	2	3	0	0	word (SP) ← (SP) +ext (imm8)	-	-	-	-	-	-	-	-	-	-
ADDSP #imm16	3	3	0	0	word (SP) ← (SP) +imm16	-	-	-	-	-	-	-	-	-	-
MOV A, brgl	2	*1	0	0	byte (A) ← (brgl)	Z	*	-	-	-	*	*	-	-	-
MOV brg2, A	2	1	0	0	byte (brg2) ← (A)	-	-	-	-	-	*	*	-	-	-
NOP	1	1	0	0	No operation	-	-	-	-	-	-	-	-	-	-
ADB	1	1	0	0	Prefix code for accessing AD space	-	-	-	-	-	-	-	-	-	-
DTB	1	1	0	0	Prefix code for accessing DT space	-	-	-	-	-	-	-	-	-	-
PCB	1	1	0	0	Prefix code for accessing PC space	-	-	-	-	-	-	-	-	-	-
SPB	1	1	0	0	Prefix code for accessing SP space	-	-	-	-	-	-	-	-	-	-
NCC	1	1	0	0	Prefix code for no flag change	-	-	-	-	-	-	-	-	-	-
CMR	1	1	0	0	Prefix code for common register bank	-	-	-	-	-	-	-	-	-	-

*1: PCB, ADB, SSB, USB, and SPB : 1 state
DTB, DPR : 2 states

*2: 7 + 3 ¥ (pop count) + 2 ¥ (last register number to be popped), 7 when rlst = 0 (no transfer register)

*3: 29 + (push count) - 3 ¥ (last register number to be pushed), 8 when rlst = 0 (no transfer register)

*4: Pop count ¥ (c), or push count ¥ (c)

*1: Pop count or push count.

Note: For an explanation of “(a)” to “(d)”, refer to Table 4, “Number of Execution Cycles for Each Type of Addressing,” and Table 5, “Correction Values for Number of Cycles Used to Calculate Number of Actual Cycles.”

Table 21 Bit Manipulation Instructions [21 Instructions]

Mnemonic	#	~	RG	B	Operation	LH	AH	I	S	T	N	Z	V	C	RMW
MOVB A, dir:bp	3	5	0	(b)	byte (A) ← (dir:bp) b	Z	*	-	-	-	*	*	-	-	-
MOVB A, addr16:bp	4	5	0	(b)	byte (A) ← (addr16:bp) b	Z	*	-	-	-	*	*	-	-	-
MOVB A, io:bp	3	4	0	(b)	byte (A) ← (io:bp) b	Z	*	-	-	-	*	*	-	-	-
MOVB dir:bp, A	3	7	0	2× (b)	bit (dir:bp) b ← (A)	-	-	-	-	-	*	*	-	-	*
MOVB addr16:bp, A	4	7	0	2× (b)	bit (addr16:bp) b ← (A)	-	-	-	-	-	*	*	-	-	*
MOVB io:bp, A	3	6	0	2× (b)	bit (io:bp) b ← (A)	-	-	-	-	-	*	*	-	-	*
SETB dir:bp	3	7	0	2× (b)	bit (dir:bp) b ← 1	-	-	-	-	-	-	-	-	-	*
SETB addr16:bp	4	7	0	2× (b)	bit (addr16:bp) b ← 1	-	-	-	-	-	-	-	-	-	*
SETB io:bp	3	7	0	2× (b)	bit (io:bp) b ← 1	-	-	-	-	-	-	-	-	-	*
CLRB dir:bp	3	7	0	2× (b)	bit (dir:bp) b ← 0	-	-	-	-	-	-	-	-	-	*
CLRB addr16:bp	4	7	0	2× (b)	bit (addr16:bp) b ← 0	-	-	-	-	-	-	-	-	-	*
CLRB io:bp	3	7	0	2× (b)	bit (io:bp) b ← 0	-	-	-	-	-	-	-	-	-	*
BBC dir:bp, rel	4	*1	0	(b)	Branch when (dir:bp) b = 0	-	-	-	-	-	-	*	-	-	-
BBC addr16:bp, rel	5	*1	0	(b)	Branch when (addr16:bp) b = 0	-	-	-	-	-	-	*	-	-	-
BBC io:bp, rel	4	*2	0	(b)	Branch when (io:bp) b = 0	-	-	-	-	-	-	*	-	-	-
BBS dir:bp, rel	4	*1	0	(b)	Branch when (dir:bp) b = 1	-	-	-	-	-	-	*	-	-	-
BBS addr16:bp, rel	5	*1	0	(b)	Branch when (addr16:bp) b = 1	-	-	-	-	-	-	*	-	-	-
BBS io:bp, rel	4	*2	0	(b)	Branch when (io:bp) b = 1	-	-	-	-	-	-	*	-	-	-
SBBS addr16:bp, rel	5	*3	0	2× (b)	Branch when (addr16:bp) b = 1, bit = 1	-	-	-	-	-	-	*	-	-	*
WBTS io:bp	3	*4	0	*5	Wait until (io:bp) b = 1	-	-	-	-	-	-	-	-	-	-
WBTC io:bp	3	*4	0	*5	Wait until (io:bp) b = 0	-	-	-	-	-	-	-	-	-	-

*1: 8 when branching, 7 when not branching

*2: 7 when branching, 6 when not branching

*3: 10 when condition is satisfied, 9 when not satisfied

*4: Undefined count

*5: Until condition is satisfied

Note: For an explanation of “(a)” to “(d)”, refer to Table 4, “Number of Execution Cycles for Each Type of Addressing,” and Table 5, “Correction Values for Number of Cycles Used to Calculate Number of Actual Cycles.”

MB90610A Series

Table 22 Accumulator Manipulation Instructions (Byte/Word) [6 Instructions]

Mnemonic	#	~	RG	B	Operation	LH	AH	I	S	T	N	Z	V	C	RMW
SWAP	1	3	0	0	byte (A) 0 to 7 ↔ (A) 8 to 15	–	–	–	–	–	–	–	–	–	–
SWAPW/XCHW AL, AH	1	2	0	0	word (AH) ↔ (AL)	–	*	–	–	–	–	–	–	–	–
EXT	1	1	0	0	byte sign extension	X	–	–	–	–	*	*	–	–	–
EXTW	1	2	0	0	word sign extension	–	X	–	–	–	*	*	–	–	–
ZEXT	1	1	0	0	byte zero extension	Z	–	–	–	–	R	*	–	–	–
ZEXTW	1	1	0	0	word zero extension	–	Z	–	–	–	R	*	–	–	–

Table 23 String Instructions [10 Instructions]

Mnemonic	#	~	RG	B	Operation	LH	AH	I	S	T	N	Z	V	C	RMW
MOVS/MOVS	2	*2	*5	*3	Byte transfer @AH+ ← @AL+, counter = RW0	–	–	–	–	–	–	–	–	–	–
MOVSD	2	*2	*5	*3	Byte transfer @AH– ← @AL–, counter = RW0	–	–	–	–	–	–	–	–	–	–
SCEQ/SCEQI	2	*1	*5	*4	Byte retrieval (@AH+) – AL, counter = RW0	–	–	–	–	–	*	*	*	*	–
SCEQD	2	*1	*5	*4	Byte retrieval (@AH–) – AL, counter = RW0	–	–	–	–	–	*	*	*	*	–
FISL/FILSI	2	6m+6	*5	*3	Byte filling @AH+ ← AL, counter = RW0	–	–	–	–	–	*	*	–	–	–
MOVSW/MOVSWI	2	*2	*8	*6	Word transfer @AH+ ← @AL+, counter = RW0	–	–	–	–	–	–	–	–	–	–
MOVSWD	2	*2	*8	*6	Word transfer @AH– ← @AL–, counter = RW0	–	–	–	–	–	–	–	–	–	–
SCWEQ/SCWEQI	2	*1	*8	*7	Word retrieval (@AH+) – AL, counter = RW0	–	–	–	–	–	*	*	*	*	–
SCWEQD	2	*1	*8	*7	Word retrieval (@AH–) – AL, counter = RW0	–	–	–	–	–	*	*	*	*	–
FILSW/FILSWI	2	6m+6	*8	*6	Word filling @AH+ ← AL, counter = RW0	–	–	–	–	–	*	*	–	–	–

m: RW0 value (counter value)

n: Loop count

*1: 5 when RW0 is 0, $4 + 7 \times (\text{RW0})$ for count out, and $7 \times n + 5$ when match occurs

*2: 5 when RW0 is 0, $4 + 8 \times (\text{RW0})$ in any other case

*3: $(b) \times (\text{RW0}) + (b) \times (\text{RW0})$ when accessing different areas for the source and destination, calculate (b) separately for each.

*4: $(b) \times n$

*5: $2 \times (\text{RW0})$

*6: $(c) \times (\text{RW0}) + (c) \times (\text{RW0})$ when accessing different areas for the source and destination, calculate (c) separately for each.

*7: $(c) \times n$

*8: $2 \times (\text{RW0})$

Note: For an explanation of “(a)” to “(d)”, refer to Table 4, “Number of Execution Cycles for Each Type of Addressing,” and Table 5, “Correction Values for Number of Cycles Used to Calculate Number of Actual Cycles.”

■ ORDERING INFORMATION

Part number	Package	Remarks
MB90611APFV	100-pin Plastic LQFP (FPT-100P-M05)	
MB90611APF	100-pin Plastic QFP (FPT-100P-M06)	

MB90610A Series

PACKAGE DIMENSIONS

100-pin Plastic LQFP (FPT-100P-M05)

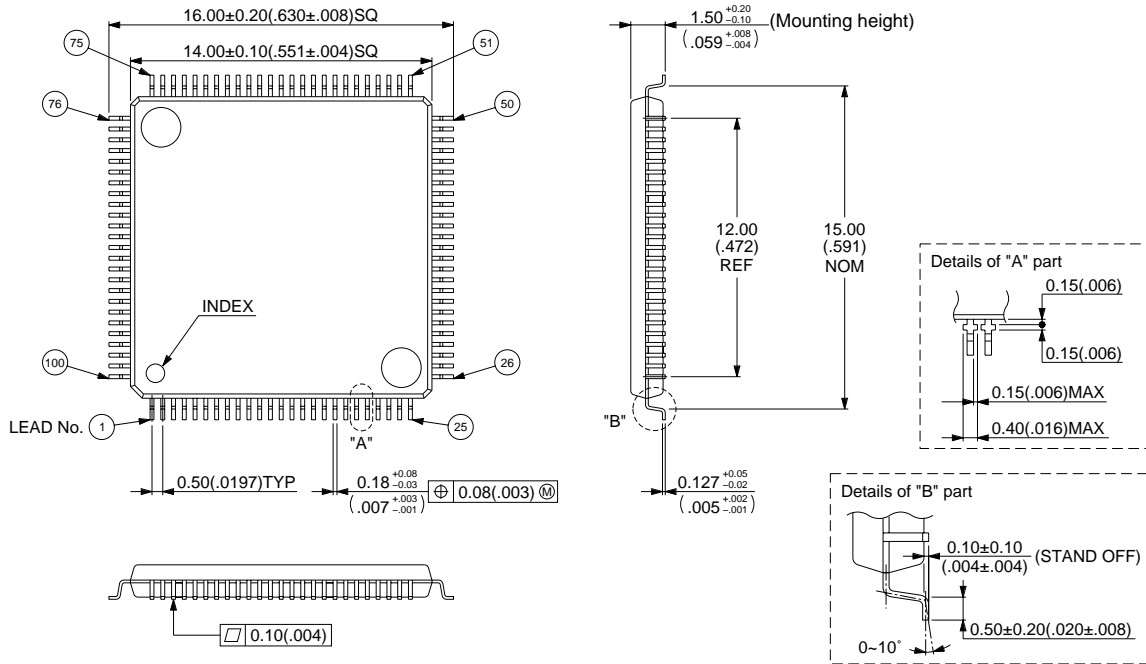

© 1995 FUJITSU LIMITED F100007S-2C-3

Dimensions in mm (inches)

100-pin Plastic QFP (FPT-100P-M06)

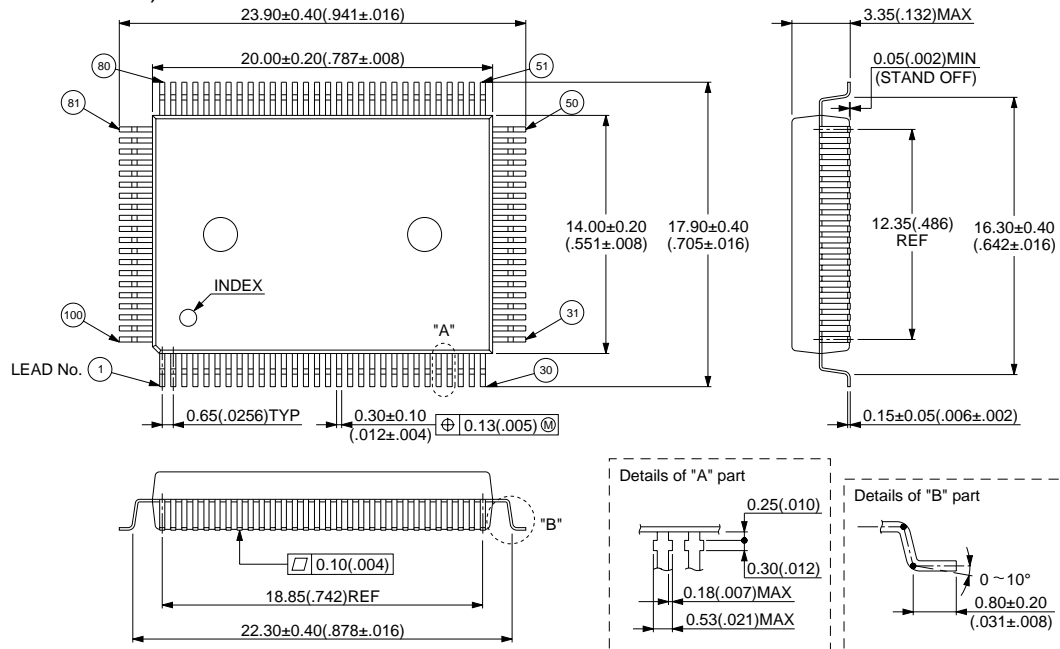

© 1994 FUJITSU LIMITED F100008-3C-2

Dimensions in mm (inches)

FUJITSU LIMITED

For further information please contact:

Japan

FUJITSU LIMITED
Corporate Global Business Support Division
Electronic Devices
KAWASAKI PLANT, 4-1-1, Kamikodanaka
Nakahara-ku, Kawasaki-shi
Kanagawa 211-8588, Japan
Tel: 81(44) 754-3763
Fax: 81(44) 754-3329

<http://www.fujitsu.co.jp/>

North and South America

FUJITSU MICROELECTRONICS, INC.
Semiconductor Division
3545 North First Street
San Jose, CA 95134-1804, USA
Tel: (408) 922-9000
Fax: (408) 922-9179

Customer Response Center
Mon. - Fri.: 7 am - 5 pm (PST)
Tel: (800) 866-8608
Fax: (408) 922-9179

<http://www.fujitsumicro.com/>

Europe

FUJITSU MIKROELEKTRONIK GmbH
Am Siebenstein 6-10
D-63303 Dreieich-Buchsschlag
Germany
Tel: (06103) 690-0
Fax: (06103) 690-122

<http://www.fujitsu-edc.com/>

Asia Pacific

FUJITSU MICROELECTRONICS ASIA PTE LTD
#05-08, 151 Lorong Chuan
New Tech Park
Singapore 556741
Tel: (65) 281-0770
Fax: (65) 281-0220

<http://www.fmap.com.sg/>

F9907

© FUJITSU LIMITED Printed in Japan

All Rights Reserved.

The contents of this document are subject to change without notice. Customers are advised to consult with FUJITSU sales representatives before ordering.

The information and circuit diagrams in this document are presented as examples of semiconductor device applications, and are not intended to be incorporated in devices for actual use. Also, FUJITSU is unable to assume responsibility for infringement of any patent rights or other rights of third parties arising from the use of this information or circuit diagrams.

FUJITSU semiconductor devices are intended for use in standard applications (computers, office automation and other office equipment, industrial, communications, and measurement equipment, personal or household devices, etc.).

CAUTION:

Customers considering the use of our products in special applications where failure or abnormal operation may directly affect human lives or cause physical injury or property damage, or where extremely high levels of reliability are demanded (such as aerospace systems, atomic energy controls, sea floor repeaters, vehicle operating controls, medical devices for life support, etc.) are requested to consult with FUJITSU sales representatives before such use. The company will not be responsible for damages arising from such use without prior approval.

Any semiconductor devices have an inherent chance of failure. You must protect against injury, damage or loss from such failures by incorporating safety design measures into your facility and equipment such as redundancy, fire protection, and prevention of over-current levels and other abnormal operating conditions.

If any products described in this document represent goods or technologies subject to certain restrictions on export under the Foreign Exchange and Foreign Trade Law of Japan, the prior authorization by Japanese government will be required for export of those products from Japan.