

M5M29KB/T331AVP

33,554,432-BIT (4,194,304-WORD BY 8-BIT /2,097,152-WORD BY 16-BIT)
CMOS 3.3V-ONLY, BLOCK ERASE FLASH MEMORY

DESCRIPTION

The M5M29KB/T331AVP are 3.3V-only high speed 33,554,432-bit CMOS boot block FLASH Memories with alternating BGO(Back Ground Operation) feature. The BGO feature of the device allows Program or Erase operations to be performed in one bank while the device simultaneously allows Read operations to be performed on the other bank.

This BGO feature is suitable for mobile and personal computing, and communication products.

The M5M29KB/T331AVP are fabricated by CMOS technology for the peripheral circuit and DINOR IV(Divided bit-line NOR IV) architecture for the memory cell, and are available in 48pin TSOP(I) for lead free use.

M5M29KB/T331AVP provides for Software Lock Release function. Usually, all memory blocks are locked and can not be programmed or erased, when WP# is low. Using Software Lock Release function, program or erase operation can be executed.

FEATURES

Access time	Random	70ns (Max.)
	Page	25ns(Max.)
Supply voltage		VCC= 3.0 ~ 3.6V
Ambient temperature		Ta=-40 ~ 85 °C
Package	48pin TSOP(Type-I), Lead pitch 0.5mm	
	Outer-lead finishing : Sn-Cu	

APPLICATION

Digital Cellar Phone, Telecommunication,
PDA, Car Navigation System, Video Game Machine

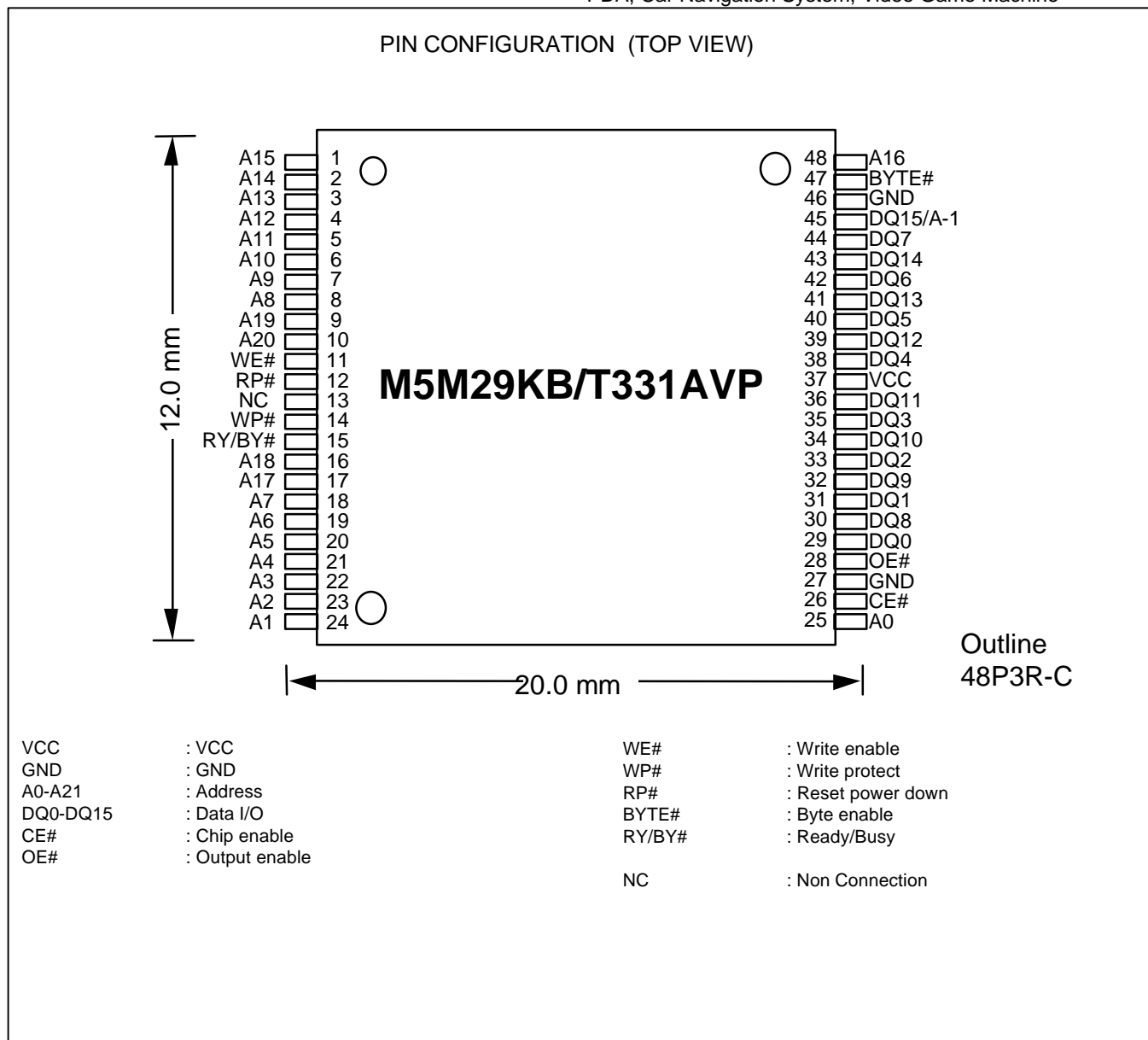

M5M29KB/T331AVP

33,554,432-BIT (4,194,304-WORD BY 8-BIT /2,097,152-WORD BY 16-BIT)
 CMOS 3.3V-ONLY, BLOCK ERASE FLASH MEMORY

32M Flash Memory Block Diagram

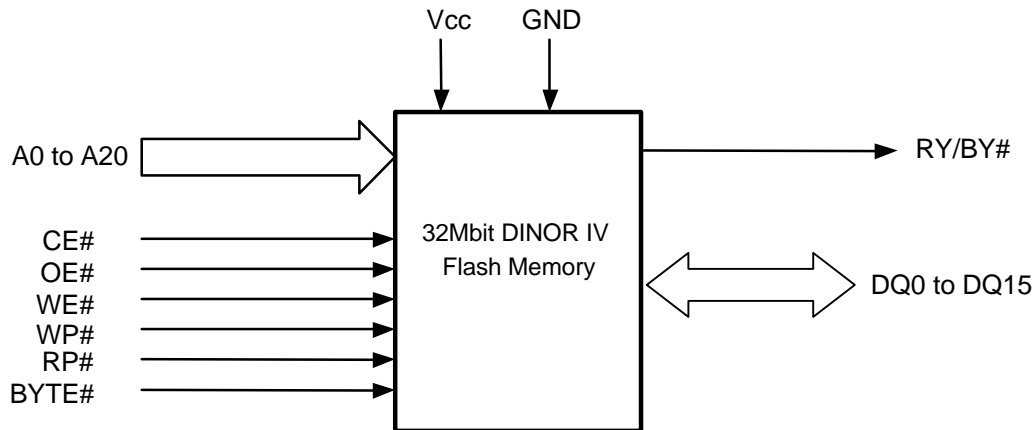

Capacitance

Symbol	Parameter		Conditions	Limits			Unit
				Min.	Typ.	Max.	
CIN	Input capacitance	A20-A0, OE#, WE#, CE#, WP#, RP#, BYTE#	Ta=25°C, f=1MHz, Vin=Vout=0V			12	pF
COUT	Output Capacitance	DQ15-DQ0, RY/BY#				12	pF

M5M29KB/T331AVP

**33,554,432-BIT (4,194,304-WORD BY 8-BIT /2,097,152-WORD BY 16-BIT)
CMOS 3.3V-ONLY, BLOCK ERASE FLASH MEMORY**

Flash Memory Part**Description**

The 32M-bit DINOR IV(Divided bit line NOR IV) Flash Memory is 3.3V-only high speed 33,554,432-bit CMOS boot block Flash Memory. Alternating BGO(Back Ground Operation) feature of the device allows Program or Erase operations to be performed in one bank while the device simultaneously allows Read operations to be performed on the other bank. This BGO feature is suitable for communication products and cellular phone. The Flash Memory is fabricated by CMOS technology for the peripheral circuits and DINOR IV architecture for the memory cells.

Features

-Organization	2,097,152-word x 16-bit 4,194,304-byte x 8-bit
- Supply Voltage	VCC = 3.0 ~ 3.6V
- Access time	
Random Access	70ns(Max.)
Random Page Read	25ns(Max.)
- Read	108mW (Max. at 5MHz)
- Page Read	36mW (Max.)
(After Automatic Power Down)	0.33μW(typ.)
- Program/Erase	126mW(Max.)
Standby	0.33μW(typ.)
Deep Power Down mode	0.33μW(typ.)
- Auto Program for Bank(I) – Bank(IV)	
Program Time	
Word Program	30μs/word(typ.)
Byte Program	30μs/byte(typ.)
Page Program	4ms(typ.)
Program Unit	
Word/Byte Program	1word/ 1Byte
Page Program	128 words/ 256 bytes

- Auto Erase		
Erase time	Main Block	150ms/block (typ.)
Erase unit		
Bank(I)		
	Boot Block	4K-word x2/ 8K-byte x2
	Parameter Block	4K-word x6 / 8K-byte x6
	Main Block	32K-word x7 / 64K-byte x7
Bank(II)	Main Block	32K-word x8 / 64K-byte x8
Bank(III)	Main Block	32K-word x24 / 64K-byte x24
Bank(IV)	Main Block	32K-word x24 / 64K-byte x24
- Program/Erase cycles		100Kcycles
- Boot Block		
Bottom Boot	M***B33*****	
Top Boot	M***T33*****	
- The Other Functions		
Software Command Control		
Software Lock Release(while WP# is low)		
Erase Suspend/Resume		
Program Suspend/Resume		
Status Register Read		
Alternating Back Ground Program/Erase Operation		
Between Bank(I), Bank(II), Bank(III) and Bank(IV)		
Random Page Read		

M5M29KB/T331AVP

33,554,432-BIT (4,194,304-WORD BY 8-BIT /2,097,152-WORD BY 16-BIT)
CMOS 3.3V-ONLY, BLOCK ERASE FLASH MEMORY

Block Diagram (32Mbit Flash Memory)

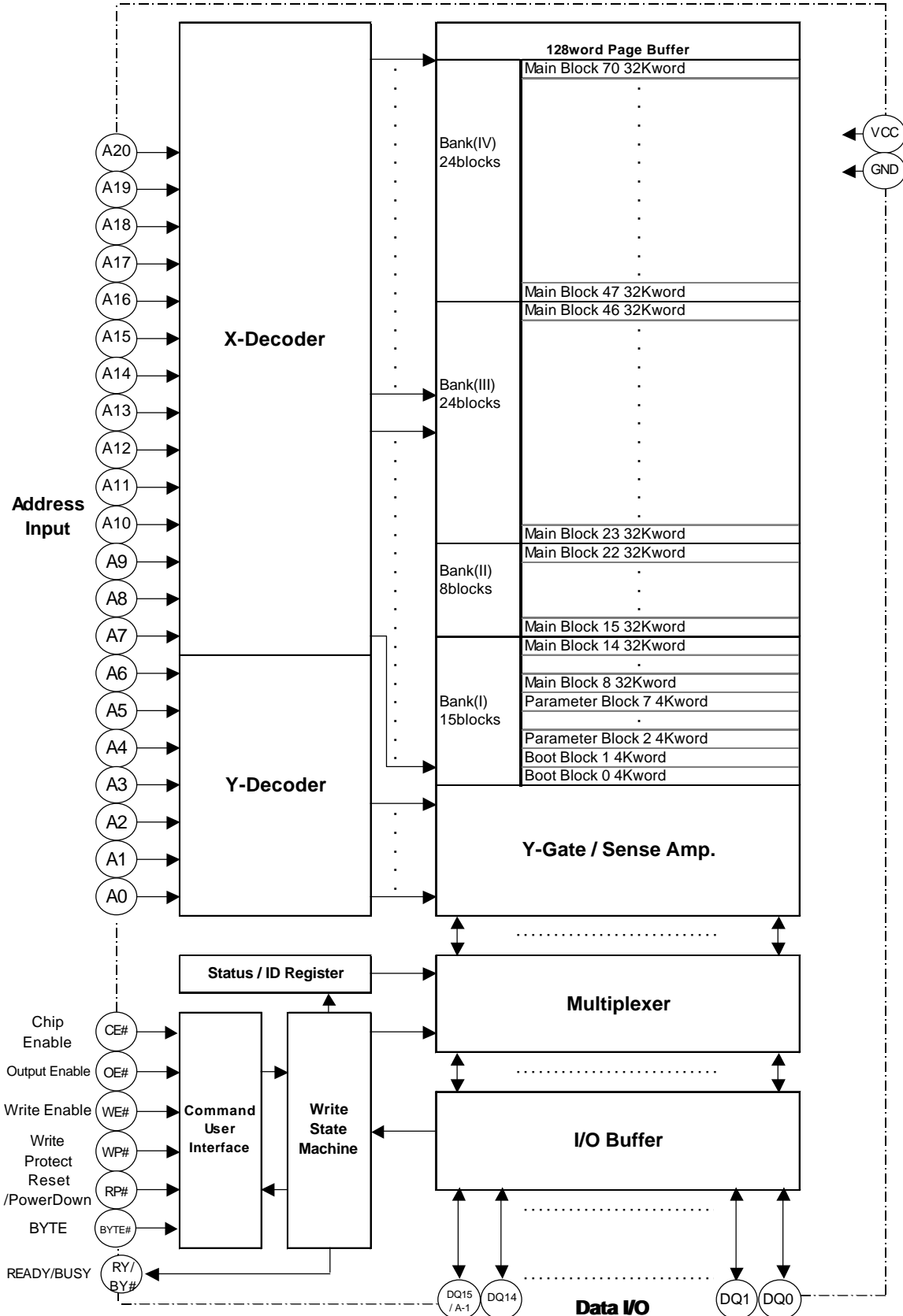

M5M29KB/T331AVP

33,554,432-BIT (4,194,304-WORD BY 8-BIT /2,097,152-WORD BY 16-BIT)
CMOS 3.3V-ONLY, BLOCK ERASE FLASH MEMORY

Function of Flash Memory

The 32M-bit DINOR IV Flash Memory includes on-chip program/erase control circuitry. The Write State Machine (WSM) controls block erase and word/page program operations. Operational modes are selected by the commands written to the Command User Interface (CUI). The Status Register indicates the status of the WSM and when the WSM successfully completes the desired program or block erase operation.

A Deep Power Down mode is enabled when the RP# pin is at GND, minimizing power consumption.

Read

The 32M-bit DINOR IV Flash Memory has four read modes, which accesses to the memory array, the Page Read, the Device Identifier and the Status Register. The appropriate read commands are required to be written to the CUI. Upon initial device power up or after exit from deep power down, the 32M-bit DINOR IV Flash Memory automatically resets to read array mode. In the read array mode and in the conditions are low level input to OE#, high level input to WE# and RP#, low level input to CE# and address signals to the address inputs (A20 - A0: Word mode / A20-A-1: Byte mode) the data of the addressed location to the data input/output (DQ15-DQ0: Word mode / DQ7- DQ0: Byte mode) is output.

Write

Writes to the CUI enables reading of memory array data, device identifiers and reading and clearing of the Status Register. They also enable block erase and program. The CUI is written by bringing WE# to low level and OE# is at high level, while CE# is at low level. Address and data are latched on the earlier rising edge of WE# and CE#. Standard micro processor write timings are used.

Alternating Background Operation (BGO)

The 32M-bit DINOR IV Flash Memory allows to read array from one bank while the other bank operates in software command write cycling or the erasing / programming operation in the background. Array Read operation with the other bank in BGO is performed by changing the bank address without any additional command. When the bank address points the bank in software command write cycling or the erasing / programming operation, the data is read out from the status register. The access time with BGO is the same as the normal read operation. BGO must be between Bank(I), Bank(II), Bank(III) and Bank(IV).

Output Disable

When OE# is at VIH, output from the devices is disabled. Data input/output are in a high-impedance (High-Z) state.

Standby

When CE# is at VIH, the device is in the standby mode and its power consumption is reduced. Data input/output are in a high-impedance (High-Z) state. If the memory is deselected during block erase or program, the internal control circuits remain active and the device consumes normal active power until the operation completes.

Deep Power Down

When RP# is at VIL, the device is in the deep power down mode and its power consumption is substantially low. During read modes, the memory is deselected and the data input/output are in a high-impedance (High-Z) state. After return from power down, the CUI is reset to Read Array, and the Status Register is cleared to value 80H.

During block erase or program modes, RP# low will abort either operation. Memory array data of the block being altered become invalid.

Automatic Power Down (Auto-PD)

The Automatic Power Down minimizes the power consumption during read mode. The device automatically turns to this mode when any addresses or CE# isn't changed more than 200ns after the last alternation. The power consumption becomes the same as the stand-by mode. During this mode, the output data is latched and can be read out. New data is read out correctly when addresses are changed.

BBR(Back Bank array Read)

In the 32M-bit DINOR IV Flash Memory, when one memory address is read according to a Read Mode in the case of the same as an access when a Read Mode command is input, another Bank memory data can be read out (Random or Page Mode) by changing another Bank address.

M5M29KB/T331AVP

33,554,432-BIT (4,194,304-WORD BY 8-BIT /2,097,152-WORD BY 16-BIT)
CMOS 3.3V-ONLY, BLOCK ERASE FLASH MEMORY

Software Command Definitions

The device operations are selected by writing specific software command into the Command User Interface.

Read Array Command (FFH)

The device is in Read Array mode on initial device power up and after exit from deep power down, or by writing FFH to the Command User Interface. After starting the internal operation the device is set to the read status register mode automatically.

Read Device Identifier Command (90H)

We can normally read device identifier codes when Read Device Identifier Code Command (90H) is written to the command latch. Following the command write, the manufacturer code and the device code can be read from A0 address 0H and 1H in a bank address, respectively.

Read Status Register Command (70H)

The Status Register is read after writing the Read Status Register command of 70H to the Command User Interface. Also, after starting the internal operation the device is set to the Read Status Register mode automatically.

The contents of Status Register are latched on the later falling edge of OE# or CE#. When status read is required, OE# or CE# must be toggled every status read.

Page Read Command (F3H)

The Page Read command (F3H) timing can be used by writing the first command and CE# falls VIL or changing the address(A20-A2) is necessary to start activating page read mode. This command is fast random 4 words read. During the read cycle operation it is necessary to fix CE# low and change addresses which are defined by A0 and A1(or A-1 to A1) at random continuously.

The mode is kept until RP# is set to VIL or this chip is powered down.

The first read of Page Read timing is the same as normal read (ta(CE)). CE# should be fallen VIL. The read timing after the first is fast read (ta(PAD)).

In the page read mode the upper address(A20-A2) is supposed not to be clocked during read operation. Otherwise the access time is as same as normal read.

Clear Status Register Command (50H)

The Erase Status, Program Status and Block Status bits are set to "1"s by the Write State Machine and can only be reset by the Clear Status Register command of 50H. These bits indicate various failure conditions.

Block Erase / Confirm Command (20H/D0H)

Automated block erase is initiated by writing the Block Erase command of 20H followed by the Confirm command of D0H. An address within the block to be erased is required. The WSM executes iterative erase pulse application and erase verify operation.

Program Commands

A) Word / Byte Program (40H)

Word / Byte program is executed by a two-command sequence. The Word/Byte program Setup command of 40H is written to the Command Interface, followed by a second write specifying the address and data to be written. The WSM controls the program pulse application and verify operation.

B) Page Program for Data Blocks (41H)

Page Program allows fast programming of 128 words/ 256 bytes of data. Writing of 41H initiates the page program operation for the Data area. From 2nd cycle to 129th cycle(Word mode)/ 257th cycle(Byte mode), write data must be serially inputted. Address A6-A0(Word mode)/ A6-A-1(Byte mode) have to be incremented from 00H to 7FH. After completion of data loading, the WSM controls the program pulse application and verify operation.

C) Single Data Load to Page Buffer (74H)

/ Page Buffer to Flash (0EH/D0H)

Single data load to the page buffer is performed by writing 74H followed by a second write specifying the column address and data. Distinct data up to 128word can be loaded to the page buffer by this two-command sequence. On the other hand, all of the loaded data to the page buffer is programmed simultaneously by writing Page Buffer to Flash command of 0EH followed by the confirm command of D0H. After completion of programming the data on the page buffer is cleared automatically.

M5M29KB/T331AVP

33,554,432-BIT (4,194,304-WORD BY 8-BIT /2,097,152-WORD BY 16-BIT)
CMOS 3.3V-ONLY, BLOCK ERASE FLASH MEMORY

Flash to Page Buffer Command (F1H/D0H)

Array data load to the page buffer is performed by writing the Flash to Page Buffer command of F1H followed by the Confirm command of D0H. An address within the page to be loaded is required. Then the array data can be copied into the other pages within the same bank by using the Page Buffer to Flash command.

Clear Page Buffer Command (55H/D0H)

Loaded data to the page buffer is cleared by writing the Clear Page Buffer command of 55H followed by the Confirm command of D0H. This command is valid for clearing data loaded by Single Data Load to Page Buffer command.

Data Protection

The 32M-bit DINOR IV Flash Memory has a master Write Protect pin (WP#). When WP# is at VIH, all blocks can be programmed or erased. When WP# is low, all blocks are in locked mode which prevents any modifications to memory blocks. Software Lock Release function is only command which allows to program or erase.

Suspend/Resume Command (B0H/D0H)

Writing the Suspend command of B0H during block erase operation interrupts the block erase operation and allows read out from another block of memory. Writing the Suspend command of B0H during program operation interrupts the program operation and allows read out from another block of memory. The Bank address is required when writing the Suspend/Resume Command. The device continues to output Status Register data when read, after the Suspend command is written to it. Polling the WSM Status and Suspend Status bits will determine when the erase operation or program operation has been suspended. At this point, writing of the Read Array command to the CUI enables reading data from blocks other than that which is suspended. When the Resume command of D0H is written to the CUI, the WSM will continue with the erase or program processes.

Erase All Unlocked Blocks Command (A7H/D0H)

The command sequence enable us to erase all blocks. The command can be used by writing Setup command A7H(1st cycle) and confirm command D0H(2nd cycle). The sequence is not valid in case of WP#=VIL.

Power Supply Voltage

When the power supply voltage is less than VLKO, Low VCC Lock-Out voltage, the device is set to the Read-only mode.

A delay time of 2 μ s is required before any device operation is initiated. The delay time is measured from the time Flash VCC reaches Flash VCCmin (3.0V).

During power up, RP# = GND is recommended. Falling in Busy status is not recommended for possibility of damaging the device.

Memory Organization

The 32M-bit DINOR IV Flash Memory is constructed by 2 boot blocks of 4K words/ 8K bytes, 6 parameter blocks of 4K words/ 8K bytes and 7 main blocks of 32K words/ 64K bytes in Bank(I), by 8 main blocks of 32K words/ 64K bytes in Bank(II) and by 24 main blocks of 32K words/ 64K bytes in Bank(III) and Bank(IV).

M5M29KB/T331AVP

33,554,432-BIT (4,194,304-WORD BY 8-BIT /2,097,152-WORD BY 16-BIT)
CMOS 3.3V-ONLY, BLOCK ERASE FLASH MEMORY

Block Organization 32M-bit DINOR(IV) Flash Memory Map (Bottom Boot)

x8 (Byte Mode)	x16 (Word Mode)			x8 (Byte Mode)	x16 (Word Mode)		
1B0000H-1BFFFFH	D8000H-DFFFFH	32Kw ord MAIN BLOCK 34	BANK(III)	3F0000H-3FFFFFH	1F8000H-1FFFFFH	32Kw ord MAIN BLOCK 70	BANK(IV)
1A0000H-1AFFFFH	D0000H-D7FFFH	32Kw ord MAIN BLOCK 33		3E0000H-3EFFFFH	1F0000H-1F7FFFH	32Kw ord MAIN BLOCK 69	
190000H-19FFFFH	C8000H-CFFFFH	32Kw ord MAIN BLOCK 32		3D0000H-3DFFFFH	1E8000H-1EFFFFH	32Kw ord MAIN BLOCK 68	
180000H-18FFFFH	C0000H-C7FFFH	32Kw ord MAIN BLOCK 31		3C0000H-3CFFFFH	1E0000H-1E7FFFH	32Kw ord MAIN BLOCK 67	
170000H-17FFFFH	B8000H-BFFFFH	32Kw ord MAIN BLOCK 30		3B0000H-3BFFFFH	1D8000H-1DFFFFH	32Kw ord MAIN BLOCK 66	
160000H-16FFFFH	B0000H-B7FFFH	32Kw ord MAIN BLOCK 29		3A0000H-3AFFFFH	1D0000H-1D7FFFH	32Kw ord MAIN BLOCK 65	
150000H-15FFFFH	A8000H-AFFFFH	32Kw ord MAIN BLOCK 28		390000H-39FFFFH	1C8000H-1CFFFFH	32Kw ord MAIN BLOCK 64	
140000H-14FFFFH	A0000H-A7FFFH	32Kw ord MAIN BLOCK 27		380000H-38FFFFH	1C0000H-1C7FFFH	32Kw ord MAIN BLOCK 63	
130000H-13FFFFH	98000H-9FFFFH	32Kw ord MAIN BLOCK 26		370000H-37FFFFH	1B8000H-1BFFFFH	32Kw ord MAIN BLOCK 62	
120000H-12FFFFH	90000H-97FFFH	32Kw ord MAIN BLOCK 25		360000H-36FFFFH	1B0000H-1B7FFFH	32Kw ord MAIN BLOCK 61	
110000H-11FFFFH	88000H-8FFFFH	32Kw ord MAIN BLOCK 24		350000H-35FFFFH	1A8000H-1AFFFFH	32Kw ord MAIN BLOCK 60	
100000H-10FFFFH	80000H-87FFFH	32Kw ord MAIN BLOCK 23		340000H-34FFFFH	1A0000H-1A7FFFH	32Kw ord MAIN BLOCK 59	
F0000H-FFFFFH	78000H-7FFFFH	32Kw ord MAIN BLOCK 22		330000H-33FFFFH	198000H-19FFFFH	32Kw ord MAIN BLOCK 58	
E0000H-EFFFFH	70000H-77FFFH	32Kw ord MAIN BLOCK 21		320000H-32FFFFH	190000H-197FFFH	32Kw ord MAIN BLOCK 57	
D0000H-DFFFFH	68000H-6FFFFH	32Kw ord MAIN BLOCK 20		310000H-31FFFFH	188000H-18FFFFH	32Kw ord MAIN BLOCK 56	
C0000H-CFFFFH	60000H-67FFFH	32Kw ord MAIN BLOCK 19		300000H-30FFFFH	180000H-187FFFH	32Kw ord MAIN BLOCK 55	
B0000H-BFFFFH	58000H-5FFFFH	32Kw ord MAIN BLOCK 18		2F0000H-2FFFFFH	178000H-17FFFFH	32Kw ord MAIN BLOCK 54	
A0000H-AFFFFH	50000H-57FFFH	32Kw ord MAIN BLOCK 17		2E0000H-2EFFFFH	170000H-177FFFH	32Kw ord MAIN BLOCK 53	
90000H-9FFFFH	48000H-4FFFFH	32Kw ord MAIN BLOCK 16		2D0000H-2DFFFFH	168000H-16FFFFH	32Kw ord MAIN BLOCK 52	
80000H-8FFFFH	40000H-47FFFH	32Kw ord MAIN BLOCK 15		2C0000H-2CFFFFH	160000H-167FFFH	32Kw ord MAIN BLOCK 51	
70000H-7FFFFH	38000H-3FFFFH	32Kw ord MAIN BLOCK 14		2B0000H-2BFFFFH	158000H-15FFFFH	32Kw ord MAIN BLOCK 50	
60000H-6FFFFH	30000H-37FFFH	32Kw ord MAIN BLOCK 13		2A0000H-2AFFFFH	150000H-157FFFH	32Kw ord MAIN BLOCK 49	
50000H-5FFFFH	28000H-2FFFFH	32Kw ord MAIN BLOCK 12		290000H-29FFFFH	148000H-14FFFFH	32Kw ord MAIN BLOCK 48	
40000H-4FFFFH	20000H-27FFFH	32Kw ord MAIN BLOCK 11	280000H-28FFFFH	140000H-147FFFH	32Kw ord MAIN BLOCK 47		
30000H-3FFFFH	18000H-17FFFH	32Kw ord MAIN BLOCK 10	270000H-27FFFFH	138000H-13FFFFH	32Kw ord MAIN BLOCK 46		
20000H-2FFFFH	10000H-17FFFH	32Kw ord MAIN BLOCK 9	260000H-26FFFFH	130000H-137FFFH	32Kw ord MAIN BLOCK 45		
10000H-1FFFFH	08000H-0FFFFH	32Kw ord MAIN BLOCK 8	250000H-25FFFFH	128000H-12FFFFH	32Kw ord MAIN BLOCK 44		
0E000H-0FFFFH	07000H-07FFFH	4Kword PARAMETER BLOCK 7	240000H-24FFFFH	120000H-127FFFH	32Kw ord MAIN BLOCK 43		
0C000H-0DFFFFH	06000H-06FFFH	4Kword PARAMETER BLOCK 6	230000H-23FFFFH	118000H-11FFFFH	32Kw ord MAIN BLOCK 42		
0A000H-0BFFFFH	05000H-05FFFH	4Kword PARAMETER BLOCK 5	220000H-22FFFFH	110000H-117FFFH	32Kw ord MAIN BLOCK 41		
08000H-09FFFFH	04000H-04FFFH	4Kword PARAMETER BLOCK 4	210000H-21FFFFH	108000H-10FFFFH	32Kw ord MAIN BLOCK 40		
06000H-07FFFFH	03000H-03FFFH	4Kword PARAMETER BLOCK 3	200000H-20FFFFH	100000H-107FFFH	32Kw ord MAIN BLOCK 39		
04000H-05FFFFH	02000H-02FFFH	4Kword PARAMETER BLOCK 2	1F0000H-1FFFFFH	F8000H-FFFFFH	32Kw ord MAIN BLOCK 38		
02000H-03FFFFH	01000H-01FFFH	4Kw ord BOOT BLOCK 1	1E0000H-1EFFFFH	F0000H-F7FFFH	32Kw ord MAIN BLOCK 37		
00000H-01FFFFH	00000H-00FFFH	4Kw ord BOOT BLOCK 0	1D0000H-1DFFFFH	E8000H-EFFFFH	32Kw ord MAIN BLOCK 36		
A20-A-1 (Byte Mode)	A20-A0 (Word Mode)		1C0000H-1CFFFFH	E0000H-E7FFFH	32Kw ord MAIN BLOCK 35		

M5M29KB/T331AVP

33,554,432-BIT (4,194,304-WORD BY 8-BIT /2,097,152-WORD BY 16-BIT)
CMOS 3.3V-ONLY, BLOCK ERASE FLASH MEMORY

Block Organization 32M-bit DINOR(IV) Flash Memory Map (Top Boot)

x8 (Byte Mode)	x16 (Word Mode)		x8 (Byte Mode)	x16 (Word Mode)	
230000H-23FFFFH	118000H-11FFFFH	32Kw ord MAIN BLOCK 35	3FE000H-3FFFFFH	1FF000H-1FFFFFH	4Kw ord BOOT BLOCK 70
220000H-22FFFFH	110000H-117FFFFH	32Kw ord MAIN BLOCK 34	3FC000H-3FDFFFFH	1FE000H-1FEFFFFH	4Kw ord BOOT BLOCK 69
210000H-21FFFFH	108000H-10FFFFH	32Kw ord MAIN BLOCK 33	3FA000H-3FBFFFFH	1FD000H-1FDFFFFH	4Kword PARAMETER BLOCK 68
200000H-20FFFFH	100000H-107FFFFH	32Kw ord MAIN BLOCK 32	3F8000H-3F9FFFFH	1FC000H-1FCFFFFH	4Kword PARAMETER BLOCK 67
1F0000H-1FFFFFH	F8000H-FFFFFH	32Kw ord MAIN BLOCK 31	3F6000H-3F7FFFFH	1FB000H-1FBFFFFH	4Kword PARAMETER BLOCK 66
1E0000H-1EFFFFH	F0000H-F7FFFFH	32Kw ord MAIN BLOCK 30	3F4000H-3F5FFFFH	1FA000H-1FAFFFFH	4Kword PARAMETER BLOCK 65
1D0000H-1DFFFFH	E8000H-EFFFFH	32Kw ord MAIN BLOCK 29	3F2000H-3F3FFFFH	1F9000H-1F9FFFFH	4Kword PARAMETER BLOCK 64
1C0000H-1CFFFFH	E0000H-E7FFFFH	32Kw ord MAIN BLOCK 28	3F0000H-3F1FFFFH	1F8000H-1F8FFFFH	4Kword PARAMETER BLOCK 63
1B0000H-1BFFFFH	D8000H-DFFFFH	32Kw ord MAIN BLOCK 27	3E0000H-3EFFFFH	1F0000H-1F7FFFFH	32Kw ord MAIN BLOCK 62
1A0000H-1AFFFFH	D0000H-D7FFFFH	32Kw ord MAIN BLOCK 26	3D0000H-3DFFFFH	1E8000H-1EFFFFH	32Kw ord MAIN BLOCK 61
190000H-19FFFFH	C8000H-CFFFFH	32Kw ord MAIN BLOCK 25	3C0000H-3CFFFFH	1E0000H-1E7FFFFH	32Kw ord MAIN BLOCK 60
180000H-18FFFFH	C0000H-C7FFFFH	32Kw ord MAIN BLOCK 24	3B0000H-3BFFFFH	1D8000H-1DFFFFH	32Kw ord MAIN BLOCK 59
170000H-17FFFFH	B8000H-BFFFFH	32Kw ord MAIN BLOCK 23	3A0000H-3AFFFFH	1D0000H-1D7FFFFH	32Kw ord MAIN BLOCK 58
160000H-16FFFFH	B0000H-B7FFFFH	32Kw ord MAIN BLOCK 22	390000H-39FFFFH	1C8000H-1CFFFFH	32Kw ord MAIN BLOCK 57
150000H-15FFFFH	A8000H-AFFFFH	32Kw ord MAIN BLOCK 21	380000H-38FFFFH	1C0000H-1C7FFFFH	32Kw ord MAIN BLOCK 56
140000H-14FFFFH	A0000H-A7FFFFH	32Kw ord MAIN BLOCK 20	370000H-37FFFFH	1B8000H-1BFFFFH	32Kw ord MAIN BLOCK 55
130000H-13FFFFH	98000H-9FFFFH	32Kw ord MAIN BLOCK 19	360000H-36FFFFH	1B0000H-1B7FFFFH	32Kw ord MAIN BLOCK 54
120000H-12FFFFH	90000H-97FFFFH	32Kw ord MAIN BLOCK 18	350000H-35FFFFH	1A8000H-1AFFFFH	32Kw ord MAIN BLOCK 53
110000H-11FFFFH	88000H-8FFFFH	32Kw ord MAIN BLOCK 17	340000H-34FFFFH	1A0000H-1A7FFFFH	32Kw ord MAIN BLOCK 52
100000H-10FFFFH	80000H-87FFFFH	32Kw ord MAIN BLOCK 16	330000H-33FFFFH	198000H-19FFFFH	32Kw ord MAIN BLOCK 51
F0000H-FFFFFH	78000H-77FFFFH	32Kw ord MAIN BLOCK 15	320000H-32FFFFH	190000H-197FFFFH	32Kw ord MAIN BLOCK 50
E0000H-EFFFFH	70000H-77FFFFH	32Kw ord MAIN BLOCK 14	310000H-31FFFFH	188000H-18FFFFH	32Kw ord MAIN BLOCK 49
D0000H-DFFFFH	68000H-67FFFFH	32Kw ord MAIN BLOCK 13	300000H-30FFFFH	180000H-187FFFFH	32Kw ord MAIN BLOCK 48
C0000H-CFFFFH	60000H-67FFFFH	32Kw ord MAIN BLOCK 12	2F0000H-2FFFFFH	178000H-17FFFFH	32Kw ord MAIN BLOCK 47
B0000H-BFFFFH	58000H-57FFFFH	32Kw ord MAIN BLOCK 11	2E0000H-2EFFFFH	170000H-177FFFFH	32Kw ord MAIN BLOCK 46
A0000H-AFFFFH	50000H-57FFFFH	32Kw ord MAIN BLOCK 10	2D0000H-2DFFFFH	168000H-16FFFFH	32Kw ord MAIN BLOCK 45
90000H-9FFFFH	48000H-47FFFFH	32Kw ord MAIN BLOCK 9	2C0000H-2CFFFFH	160000H-167FFFFH	32Kw ord MAIN BLOCK 44
80000H-8FFFFH	40000H-47FFFFH	32Kw ord MAIN BLOCK 8	2B0000H-2BFFFFH	158000H-15FFFFH	32Kw ord MAIN BLOCK 43
70000H-7FFFFH	38000H-37FFFFH	32Kw ord MAIN BLOCK 7	2A0000H-2AFFFFH	150000H-157FFFFH	32Kw ord MAIN BLOCK 42
60000H-6FFFFH	30000H-37FFFFH	32Kw ord MAIN BLOCK 6	290000H-29FFFFH	148000H-14FFFFH	32Kw ord MAIN BLOCK 41
50000H-5FFFFH	28000H-27FFFFH	32Kw ord MAIN BLOCK 5	280000H-28FFFFH	140000H-147FFFFH	32Kw ord MAIN BLOCK 40
40000H-4FFFFH	20000H-27FFFFH	32Kw ord MAIN BLOCK 4	270000H-27FFFFH	138000H-13FFFFH	32Kw ord MAIN BLOCK 39
30000H-3FFFFH	18000H-17FFFFH	32Kw ord MAIN BLOCK 3	260000H-26FFFFH	130000H-137FFFFH	32Kw ord MAIN BLOCK 38
20000H-2FFFFH	10000H-17FFFFH	32Kw ord MAIN BLOCK 2	250000H-25FFFFH	128000H-12FFFFH	32Kw ord MAIN BLOCK 37
10000H-0FFFFH	08000H-07FFFFH	32Kw ord MAIN BLOCK 1	240000H-24FFFFH	120000H-127FFFFH	32Kw ord MAIN BLOCK 36
00000H-0FFFFH	00000H-07FFFFH	32Kw ord MAIN BLOCK 0	A20-A-1 (Byte Mode)	A20-A0 (Word Mode)	

BANK(III)

BANK(IV)

BANK(I)

BANK(II)

BANK(III)

M5M29KB/T331AVP

33,554,432-BIT (4,194,304-WORD BY 8-BIT /2,097,152-WORD BY 16-BIT)
CMOS 3.3V-ONLY, BLOCK ERASE FLASH MEMORY

Bus Operation**BYTE#=VIH**

Mode \ Pins		CE#	OE#	WE#	RP#	DQ0-15	RY/BY#
Read	Array	VIL	VIL	VIH	VIH	Data Output	VOH(Hi-Z)
	Page	VIL	VIL	VIH	VIH	Data Output	VOH(Hi-Z)
	Status Register	VIL	VIL	VIH	VIH	Status Register Data	X ²⁾
	Identifier Code	VIL	VIL	VIH	VIH	Identifier Code	VOH(Hi-Z)
Output Disable		VIL	VIH	VIH	VIH	High-Z	X ²⁾
Write	Program	VIL	VIH	VIL	VIH	Command/Data in	X ²⁾
	Erase	VIL	VIH	VIL	VIH	Command	X ²⁾
	Others	VIL	VIH	VIL	VIH	Command	X ²⁾
Stand by		VIH	X ¹⁾	X ¹⁾	VIH	High-Z	X ²⁾
Deep Power Down		X ¹⁾	X ¹⁾	X ¹⁾	VIL	High-Z	VOH(Hi-Z)

BYTE#=VIL

Mode \ Pins		CE#	OE#	WE#	RP#	DQ0-7	RY/BY#
Read	Array	VIL	VIL	VIH	VIH	Data Output	VOH(Hi-Z)
	Page	VIL	VIL	VIH	VIH	Data Output	VOH(Hi-Z)
	Status Register	VIL	VIL	VIH	VIH	Status Register Data	X ²⁾
	Identifier Code	VIL	VIL	VIH	VIH	Identifier Code	VOH(Hi-Z)
Output Disable		VIL	VIH	VIH	VIH	High-Z	X ²⁾
Write	Program	VIL	VIH	VIL	VIH	Command/Data in	X ²⁾
	Erase	VIL	VIH	VIL	VIH	Command	X ²⁾
	Others	VIL	VIH	VIL	VIH	Command	X ²⁾
Stand by		VIH	X ¹⁾	X ¹⁾	VIH	High-Z	X ²⁾
Deep Power Down		X ¹⁾	X ¹⁾	X ¹⁾	VIL	High-Z	VOH(Hi-Z)

- 1) X can be VIH or VIL for control pins.
- 2) X at RY/BY# is VOL or VOH (Hi-Z).

*The RY/BY# is an open drain output pin and indicates status of the internal WSM. When low, it indicates that WSM is Busy performing an operation.

A pull-up resistor of 10K-100K Ohms is required to allow the RY/BY# signal to transition high indicating a Ready WSM condition.

M5M29KB/T331AVP

**33,554,432-BIT (4,194,304-WORD BY 8-BIT /2,097,152-WORD BY 16-BIT)
CMOS 3.3V-ONLY, BLOCK ERASE FLASH MEMORY**

Software Command Definition**Command List (WP# =VIH or VIL)**

Command	1st Bus Cycle			2nd Bus Cycle			3rd-5th Bus Cycles (Word mode) 3rd-9th Bus Cycles (Byte mode)			
	Mode	Address	Data ¹⁾ (DQ0-15),(DQ0-7)	Mode	Address		Data (DQ0-15),(DQ0-7)	Mode	Address	Data (DQ0-15),(DQ0-7)
					A20-A18	A0				
Read Array	Write	X	FFH							
Page Read	Write	X	F3H	Read	SA ⁵⁾		RD0 ⁵⁾	Read	SA+i ⁶⁾	RDi ⁶⁾
Device Identifier	Write	Bank ²⁾	90H	Read	Bank ²⁾	IA ³⁾	ID ³⁾			
Read Status Register	Write	Bank ²⁾	70H	Read	Bank ²⁾		SRD ⁴⁾			
Clear Status Register	Write	X	50H							
Suspend	Write	Bank ²⁾	B0H							
Resume	Write	Bank ²⁾	D0H							

1) In the case of Word mode(BYTE#=VIH), upper byte data (DQ15-DQ8) is ignored.

2) Bank=Bank address (Bank(I)-Bank(IV): A20-18)

3) IA=ID code address: A0=VIL (Manufacturer's code): A0=VIH (Device code), ID=ID code

4) SRD=Status Register Data

5) SA=A20-A2: Page Address, A1, A0(A1-A-1):voluntary address / RD0=1st Page read data

6) SA+i: Page address(is equal to 1st Page Address of A20-A2), A1,A0(A1-A-1): voluntary address / RDi: 2nd Page read data

Command List (WP# =VIH)

Command	1st Bus Cycle			2nd Bus Cycle			3rd-129th Bus Cycles (Word mode) 3rd-257th Bus Cycles (Byte mode)			
	Mode	Address	Data ¹⁾ (DQ0-15),(DQ0-7)	Mode	Address		Data ¹⁾ (DQ0-15),(DQ0-7)	Mode	Address	Data ¹⁾ (DQ0-15),(DQ0-7)
					WA	WD				
Word Program	Write	Bank ²⁾	40H	Write	WA ³⁾	WD ³⁾				
Page Program	Write	Bank ²⁾	41H	Write	WA0 ⁴⁾	WD0 ⁴⁾	Write	WAn ⁴⁾	WDn ⁴⁾	
Page Buffer to Flash	Write	Bank ²⁾	0EH	Write	WA ⁵⁾	D0H ¹⁾				
Block Erase/Confirm	Write	Bank ²⁾	20H	Write	BA ⁶⁾	D0H ¹⁾				
Erase All Unlocked Blocks	Write	X	A7H	Write	X	D0H ¹⁾				
Clear Page Buffer	Write	X	55H	Write	X	D0H ¹⁾				
Single Data Load to Page Buffer	Write	Bank ²⁾	74H	Write	WA ³⁾	WD ³⁾				
Flash to Page Buffer	Write	Bank ²⁾	F1H	Write	RA ⁷⁾	D0H ¹⁾				

1) In the case of Word mode(BYTE#=VIH),Upper byte data (DQ15-DQ8) is ignored.

2) Bank=Bank address (Bank(I)-Bank(IV): A20-A18)

3) WA=Write Address, WD=Write Data

4) WA0, WAn=Write Address, WD0, WDn=Write Data.

Word mode (BYTE#=VIH) : Write address and write data must be provided sequentially from 00H to 7FH for A6-A0.

Page size is 128 words (128-word x 16-bit), and also A20-A7 (block address, page address) must be valid.

Byte mode (BYTE#=VIL) : Write address and write data must be provided sequentially from 00H to FFH for A6-A-1.

Page size is 256 Bytes (256-byte x 8-bit), and also A20-A7 (block address, page address) must be valid.

5) WA=Write Address: A20-A7 (block address, page address) must be valid.

6) BA=Block Address : A20-A12[Bank(I)], A20-A15 [Bank(II), Bank(III), Bank(IV)] must be valid.

7) RA=Read Address: A20-A7 (block address, page address) must be valid.

M5M29KB/T331AVP

**33,554,432-BIT (4,194,304-WORD BY 8-BIT /2,097,152-WORD BY 16-BIT)
CMOS 3.3V-ONLY, BLOCK ERASE FLASH MEMORY**

Software Command Definition

Command List (WP# =VIL)

Software lock release operation needs following consecutive 7bus cycles. Moreover, additional 127(255) bus cycles are needed for page program operation.

Setup Command for Software Lock Release	1st Bus Cycle			2nd Bus Cycle			3rd Bus Cycle		
	Mode	Address	Data ¹⁾ (DQ0-15/DQ0-7)	Mode	Address	Data ¹⁾ (DQ0-15/DQ0-7)	Mode	Address	Data ¹⁾ (DQ0-15/DQ0-7)
Word/Byte Program	Write	Bank	60H	Write	Bank	Block ⁶⁾	Write	Bank	ACH
Page Program	Write	Bank	60H	Write	Bank	Block ⁶⁾	Write	Bank	ACH
Page Buffer to Flash	Write	Bank	60H	Write	Bank	Block ⁶⁾	Write	Bank	ACH
Block Erase/Confirm	Write	Bank	60H	Write	Bank	Block ⁶⁾	Write	Bank	ACH
Clear Page Buffer	Write	Bank	60H	Write	Bank	Block ⁶⁾	Write	Bank	ACH
Single Data Load to Page Buffer	Write	Bank	60H	Write	Bank	Block ⁶⁾	Write	Bank	ACH
Flash to Page Buffer	Write	Bank	60H	Write	Bank	Block ⁶⁾	Write	Bank	ACH

Setup Command for Software Lock Release	4th Bus Cycle			5th Bus Cycle		
	Mode	Address	Data ¹⁾ (DQ0-15/DQ0-7)	Mode	Address	Data ¹⁾ (DQ0-15/DQ0-7)
Word/Byte Program	Write	Bank	Block# ⁶⁾	Write	Bank	7BH
Page Program	Write	Bank	Block# ⁶⁾	Write	Bank	7BH
Page Buffer to Flash	Write	Bank	Block# ⁶⁾	Write	Bank	7BH
Block Erase/Confirm	Write	Bank	Block# ⁶⁾	Write	Bank	7BH
Clear Page Buffer	Write	Bank	Block# ⁶⁾	Write	Bank	7BH
Single Data Load to Page Buffer	Write	Bank	Block# ⁶⁾	Write	Bank	7BH
Flash to Page Buffer	Write	Bank	Block# ⁶⁾	Write	Bank	7BH

Setup Command for Program or Erase Operations	6th Bus Cycle			7th Bus Cycle			8th-134th Bus Cycles(Word mode) 8th-262th Bus Cycles(Byte mode)		
	Mode	Address	Data ¹⁾ (DQ0-15/DQ0-7)	Mode	Address	Data (DQ0-15/DQ0-7)	Mode	Address	Data (DQ0-15/DQ0-7)
Word/Byte Program	Write	Bank	40H	Write	WA ²⁾	WD ²⁾			
Page Program	Write	Bank	41H	Write	WA0 ³⁾	WD0 ³⁾	Write	WAn ³⁾	WDn ³⁾
Page Buffer to Flash	Write	Bank	0EH	Write	WA ⁴⁾	D0H ¹⁾			
Block Erase/Confirm	Write	Bank	20H	Write	BA ⁵⁾	D0H ¹⁾			
Clear Page Buffer	Write	X	55H	Write	X	D0H ¹⁾			
Single Data Load to Page Buffer	Write	Bank	74H	Write	WA ²⁾	WD ²⁾			
Flash to Page Buffer	Write	Bank	F1H	Write	RA ⁷⁾	D0H ¹⁾			

1) In the case of word mode(BYTE#=VIH) upper byte data (DQ15-DQ8) is ignored.

2) WA=Write Address, WD=Write Data

3) WA0, WAn=Write Address, WD0, WDn=Write Data. Write address and write data must be provided sequentially from 00H to 7FH for A6-A0(word mode) and from 00H to FFH for A6-A-1(byte mode), respectively.

Page size is 128 words (128-word x 16-bit/ word mode) or Page size is 256 bytes (256-word x 8-bit/ byte mode), and also A20-A7 (block address, page address) must be valid.

4) WA=Write Address: A20-A7 (block address, page address) must be valid.

5) BA=Block Address : A20-A12[Bank(I)], A20-A15 [Bank(II), Bank(III), Bank(IV)]

6) Block=Block Address: A20-A15, Block#=A20#-A15# must be valid.

Address	DQ7	DQ6	DQ5	DQ4	DQ3	DQ2	DQ1	DQ0
Block	fixed 0	fixed 0	A20	A19	A18	A17	A16	A15
Block#	fixed 0	fixed 0	A20#	A19#	A18#	A17#	A16#	A15#

7) RA=Read Address: A20-A7 (block address, page address) must be valid.

M5M29KB/T331AVP

33,554,432-BIT (4,194,304-WORD BY 8-BIT /2,097,152-WORD BY 16-BIT)
CMOS 3.3V-ONLY, BLOCK ERASE FLASH MEMORY

Block Locking

RP#	WP#	Write Protection Provided					Notes
		Bank(I)		Bank(II)	Bank(III)	Bank(IV)	
		Boot	Parameter/Main	Main	Main	Main	
VIL	X	Locked	Locked	Locked	Locked	Locked	Deep Power Down Mode
VIH	VIL	Locked	Locked	Locked	Locked	Locked	All Blocks Locked(Valid to operate Software Lock Release)
	VIH	Unlocked	Unlocked	Unlocked	Unlocked	Unlocked	All Blocks Unlocked

WP# pin must not be switched during performing Read / Write operations or WSM busy (WSMS=0).

Status Register

Symbol (I/O Pin)	Status	Definition	
		"1"	"0"
S.R. 7 (DQ7)	Write State Machine Status	Ready	Busy
S.R. 6 (DQ6)	Suspend Status	Suspended	Operation in Progress/Completed
S.R. 5 (DQ5)	Erase Status	Error	Successful
S.R. 4 (DQ4)	Program Status	Error	Successful
S.R. 3 (DQ3)	Block Status after Erase	Error	Successful
S.R. 2 (DQ2)	Reserved	-	-
S.R. 1 (DQ1)	Reserved	-	-
S.R. 0 (DQ0)	Reserved	-	-

M5M29KB/T331AVP

**33,554,432-BIT (4,194,304-WORD BY 8-BIT /2,097,152-WORD BY 16-BIT)
CMOS 3.3V-ONLY, BLOCK ERASE FLASH MEMORY**

Device ID Code

Code	Pins									
	A0	DQ7	DQ6	DQ5	DQ4	DQ3	DQ2	DQ1	DQ0	Hex. Data
Manufacturer Code	VIL	"0"	"0"	"0"	"1"	"1"	"1"	"0"	"0"	1CH
Device Code (Top Boot)	VIH	"0"	"0"	"1"	"1"	"1"	"0"	"0"	"0"	38H
Device Code (Bottom Boot)	VIH	"0"	"0"	"1"	"1"	"1"	"0"	"0"	"1"	39H

In the case of word mode, The output of upper byte data (DQ15-DQ8) is "0H".

Absolute Maximum Ratings

Symbol	Parameter	Conditions	Min.	Max.	Units
VCC	VCC Voltage	With Respect to GND	-0.2	4.6	V
VI1	All Input or Output Voltage ¹⁾		-0.6	4.6	V
Ta	Ambient Temperature		-40	85	°C
Tbs	Temperature under Bias		-50	95	°C
Tstg	Storage Temperature		-65	125	°C
Iout	Output Short Circuit Current			100	mA

¹⁾Minimum DC voltage is -0.5V on input / output pins. During transitions, the level may undershoot to -2.0V for periods <20ns. Maximum DC voltage on input / output pins is VCC+0.5V which, during transitions, may overshoot to VCC+1.5V for periods <20ns.

DC electrical characteristics (Ta= -40 ~85 °C and Flash VCC=3.0V~3.6V, unless otherwise noted)

Symbol	Parameter	Test Conditions	Limits			Units
			Min.	Typ. ¹⁾	Max.	
ILI	Input Leakage Current	$0V \leq V_{IN} \leq V_{CC}$	-1.0		+1.0	μA
ILO	Output Leakage Current	$0V \leq V_{OUT} \leq V_{CC}$	-10		+10	μA
ISB2	VCC Stand by Current	VCC= 3.6V, VIN= GND/VCC, CE#= RP#= VCC ±0.3V		0.1	6	μA
ISB3	VCC Deep Power Down Current	VCC= 3.6V, VIN= VIL/VIH, RP#= VIL		5	25	μA
ISB4		VCC= 3.6V, VIN= GND or VCC, RP#= GND±0.3V		0.1	6	μA
ICC1	VCC Read Current for Word / byte	Vcc = 3.6V, VIN = VIL/VIH, RP# = OE# = WE# = VIH, CE# = VIL, Iout = 0mA	5MHz	20	30	mA
			1MHz	4	8	mA
ICC1P	VCC Page Read Current	Vcc = 3.6V, VIN = VIL/VIH, RP# = OE# = WE# = VIH, CE# = VIL, Iout = 0mA		5	10	mA
ICC2	VCC Write Current for Word / byte	Vcc = 3.6V, VIN = VIL/VIH, RP# = OE# = VIH, CE# = WE# = VIL			15	mA
ICC3	VCC Program Current	VCC = 3.6V, VIN = VIL/VIH, CE#= RP# = VIH			35	mA
ICC4	VCC Erase Current	VCC = 3.6V, VIN = VIL/VIH, CE#= RP# = VIH			35	mA
ICC5	VCC Suspend Current	VCC = 3.6V, VIN = VIL/VIH, CE#= RP# = VIH			200	μA
VIL	Input Low Voltage		-0.5		0.4	V
VIH	Input High Voltage		2.4		VCC+0.5	V
VOL	Output Low Voltage	IOL = 4.0mA			0.45	V
VOH1	Output High Voltage	IOH = -2.0mA		0.85xVCC		V
VOH2		IOH = -100uA		VCC-0.4		V
VLKO	Low VCC Lock Out Voltage ²⁾		1.5		2.2	V

All currents are in RMS unless otherwise noted.

1) Typical values at Flash VCC=3.3V, Ta=25 °C.

2) To protect against initiation of write cycle during Flash VCC power up / down, a write cycle is locked out for Flash VCC less than VLKO. If Flash VCC is less than VLKO, Write State Machine is reset to read mode. When the Write State Machine is in Busy state, if Flash VCC is less than VLKO, the alteration of memory contents may occur.

M5M29KB/T331AVP

33,554,432-BIT (4,194,304-WORD BY 8-BIT /2,097,152-WORD BY 16-BIT)
CMOS 3.3V-ONLY, BLOCK ERASE FLASH MEMORY

AC electrical characteristics (Ta=-40 ~85 °C and Flash VCC=3.0V~3.6V, unless otherwise noted)

Read Only Mode

Symbol		Parameter	Limits			Units
			Flash VCC=3.0-3.6V			
			Min.	Typ.	Max.	
tRC	tAVAV	Read Cycle Time	70			ns
ta(AD)	tAVQV	Address Access Time			70	ns
ta(CE)	tELQV	Chip Enable Access Time			70	ns
ta(OE)	tGLQV	Output Enable Access Time			30	ns
ta(PAD)		Page Read Access Time (after 2nd access)			25	ns
tCEPH		CE# "H" Pulse width	30			ns
tCLZ	tELQX	Chip Enable to Output in Low-Z	0			ns
tDF(CE)	tEHQZ	Chip Enable High to Output in High-Z			25	ns
tOLZ	tGLQX	Output Enable to Output in Low-Z	0			ns
tDF(OE)	tGHQZ	Output Enable to High to Output in High-Z			25	ns
tPHZ	tPLQZ	RP# Low to Output High-Z			150	ns
ta(BYTE)	tFL/HQV	BYTE# access time			70	ns
tBHZ	tFLQZ	BYTE# low to output high-Z			25	ns
tOH	tOH	Output Hold from CE#, OE# and Address	0			ns
tBCD	tELFL/H	CE# low to BYTE# high or low			5	ns
tBAD	tAVFL/H	Address to BYTE# high or low			5	ns
tOEH	tWHGL	OE# Hold from WE# High	10			ns
tPS	tPHEL	RP# Recovery to CE# Low	150			ns

-Timing measurements are made under AC waveforms for read operations.

M5M29KB/T331AVP

33,554,432-BIT (4,194,304-WORD BY 8-BIT /2,097,152-WORD BY 16-BIT)
CMOS 3.3V-ONLY, BLOCK ERASE FLASH MEMORY

AC electrical characteristics (Ta=-40 ~85 °C and Flash VCC=3.0V~3.6V, unless otherwise noted)**Read / Write Mode (WE# control)**

Symbol	Parameter	Limits			Units	
		Flash VCC=3.0-3.6V				
		Min.	Typ.	Max.		
tWC	tAVAV	Write Cycle Time	70		ns	
tAS	tAVWH	Address Setup Time	35		ns	
tAH	tWHAX	Address Hold Time	0		ns	
tDS	tDVWH	Data Setup Time	35		ns	
tDH	tWHDX	Data Hold Time	0		ns	
tOE#H	tWHGL	OE# Hold from WE# High	10		ns	
tCS	tELWL	Chip Enable Setup Time	0		ns	
tCH	tWHEH	Chip Enable Hold Time	0		ns	
tWP	tWLWH	Write Pulse Width	35		ns	
tWPH	tWHWL	Write Pulse Width High	30		ns	
tBS	tFL/HWH	Byte enable high or low set-up time	50		ns	
tBH	tWFL/H	Byte enable high or low hold time	70		ns	
tGHWL	tGHWL	OE# Hold to WE# Low	0		ns	
tBLS	tPHHWH	Block Lock Setup to Write Enable High	70		ns	
tBLH	tQVPH	Block Lock Hold from Valid SRD	0		ns	
tDAP	tWHRH1	Duration of Auto Program Operation(Byte Mode)		30	300	μs
tDAP	tWHRH1	Duration of Auto Program Operation(Word Mode)		30	300	μs
tDAP	tWHRH1	Duration of Auto Program Operation(Page Mode)		4	80	ms
tDAE	tWHRH2	Duration of Auto Block Erase Operation		150	600	ms
tWHRL	tWHRL	Write Enable High to RY/BY# Low			70	ns
tPS	tPHWL	RP# Recovery to WE# Low	150			ns

- Read timing parameters during command write operations mode are the same as during read only operation mode.
- Typical values at Flash VCC=3.3V and Ta=25 °C.

Read / Write Mode (CE# control)

Symbol	Parameter	Limits			Units	
		Flash VCC=3.0-3.6V				
		Min.	Typ.	Max.		
tWC	tAVAV	Write Cycle Time	70		ns	
tAS	tAVEH	Address Setup Time	35		ns	
tAH	tEHAX	Address Hold Time	0		ns	
tDS	tDVEH	Data Setup Time	35		ns	
tDH	tEHDX	Data Hold Time	0		ns	
tOE#H	tEHGL	OE# Hold from CE# High	10		ns	
tWS	tWLEL	Write Enable Setup Time	0		ns	
tWH	tEHWH	Write Enable Hold Time	0		ns	
tCEP	tELEH	CE# Pulse Width	35		ns	
tCEPH	tEHEL	CE#"H" Pulse Width	30		ns	
tBS	tFL/HEH	Byte enable high or low set-up time	50		ns	
tBH	tEHFL/H	Byte enable high or low hold time	70		ns	
tGHLEL	tGHLEL	OE# Hold to CE# Low	70		ns	
tBLS	tPHHEH	Block Lock Setup to Chip Enable High	70		ns	
tBLH	tQVPH	Block Lock Hold from Valid SRD	0		ns	
tDAP	tEHRH1	Duration of Auto Program Operation(Byte Mode)		30	300	μs
tDAP	tEHRH1	Duration of Auto Program Operation(Word Mode)		30	300	μs
tDAP	tEHRH1	Duration of Auto Program Operation(Page Mode)		4	80	ms
tDAE	tEHRH2	Duration of Auto Block Erase Operation		150	600	ms
tEHL	tEHL	CE# High to RY/BY# Low			70	ns
tPS	tPEL	RP# Recovery to CE# Low	150			ns

- Timing measurements are made under AC waveforms for read operations.
- Typical values at Flash VCC=3.3V and Ta=25 °C.

M5M29KB/T331AVP

33,554,432-BIT (4,194,304-WORD BY 8-BIT /2,097,152-WORD BY 16-BIT)
CMOS 3.3V-ONLY, BLOCK ERASE FLASH MEMORY

Program / Erase Time

Parameter	Min.	Typ.	Max.	Units
Block Erase Time		150	600	ms
Main Block Write Time (Byte Mode)		2	8	sec
Main Block Write Time (Word Mode)		1	4	sec
Page Write Time		4	80	ms
Flash to Page Buffer Time		100	150	μs

Program Suspend / Erase Suspend Time

Parameter	Min.	Typ.	Max.	Unit
Program Suspend Time			15	μs
Erase Suspend Time			15	μs

Flash VCC Power Up / Down Timing

symbol	Parameter	Min.	Typ.	Max.	Unit
tVCS	RP#=VIH Setup Time from Flash VCC min.	2			μs

During power up / down, by the noise pulses on control pins, the device has possibility of accidental erase of programming. The device must be protected against initiation of write cycle for memory contents during power up / down. The delay time of min. 2 μsec is always required before read operation or write operation is initiated from the time Flash VCC reaches Flash VCC min. during power up /down. By holding RP#=VIL, the contents of memory is protected during Flash VCC power up / down. During power up, RP# must be held VIL for min. 2μs from the time Flash VCC reaches Flash VCC min.. During power down, RP# must be held VIL until Flash VCC reaches GND. RP# doesn't have latch mode, therefore RP# must be held VIH during read operation or erase / program operation.

M5M29KB/T331AVP

33,554,432-BIT (4,194,304-WORD BY 8-BIT /2,097,152-WORD BY 16-BIT)
CMOS 3.3V-ONLY, BLOCK ERASE FLASH MEMORY

Flash VCC Power up / down Timing

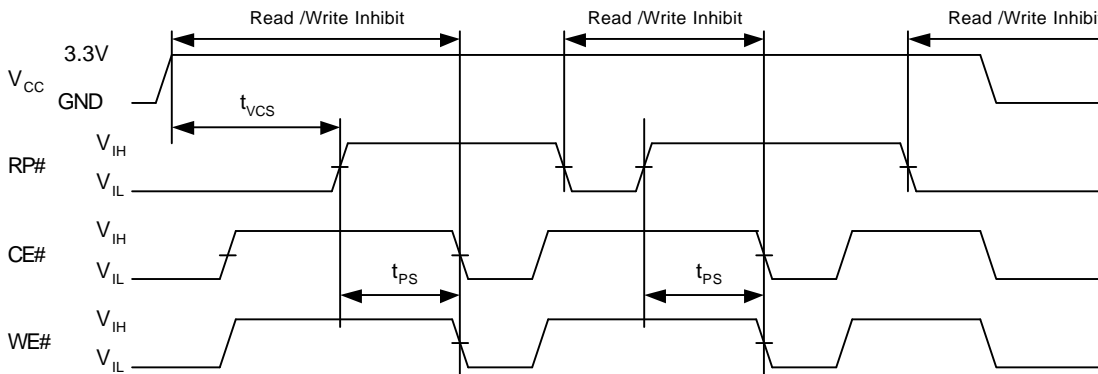

AC Waveforms for Read Operation and Test Conditions

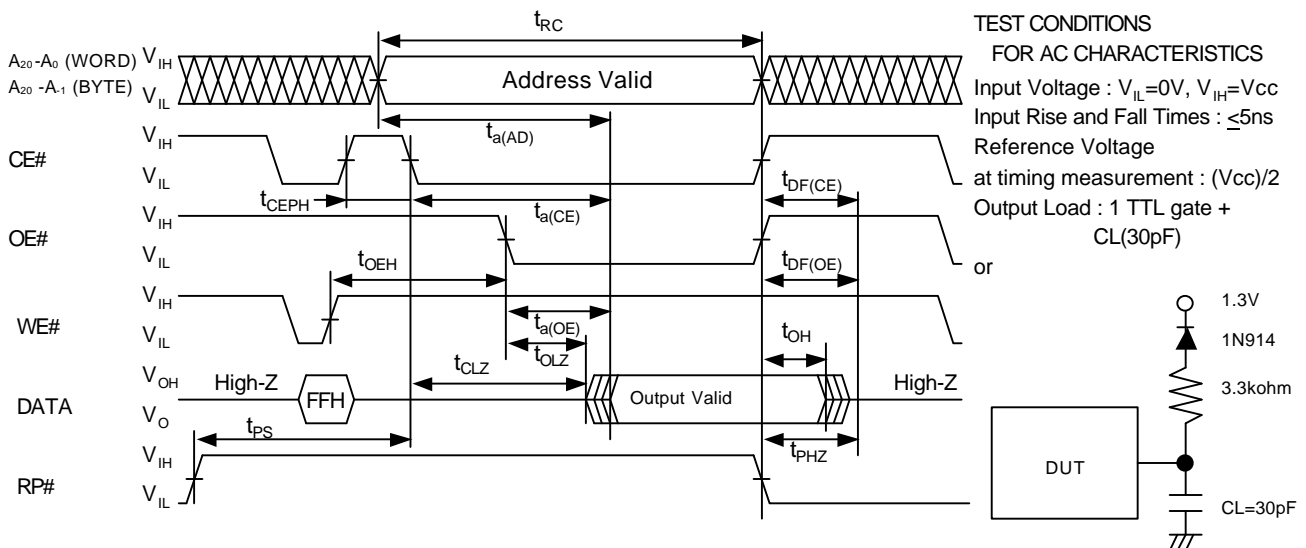

- After inputting Read Array Command FFH, it is necessary to make CE# "H" pulse more than 30ns (t_{CEPH}). And after inputting Read Array Command FFH, it is also necessary to keep 30ns to recover before starting read after WE# rises "H" in case of changing address(es) and CE#="L".

M5M29KB/T331AVP

33,554,432-BIT (4,194,304-WORD BY 8-BIT /2,097,152-WORD BY 16-BIT)
CMOS 3.3V-ONLY, BLOCK ERASE FLASH MEMORY

AC waveforms for Page Read Operation

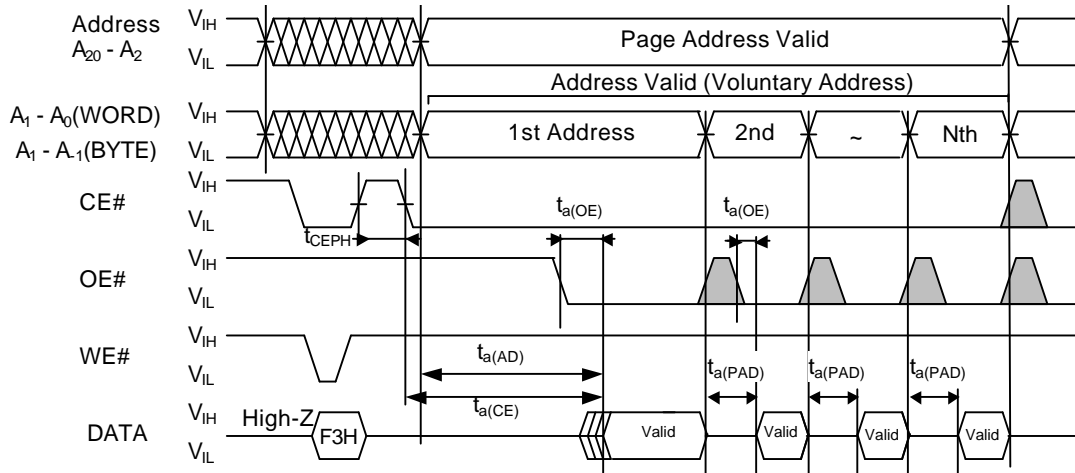

- After inputting Page Read Command F3H, it is necessary to make CE# "H" pulse more than 30ns (t_{CEPH}). And after inputting Page Read Command F3H, it is also necessary to keep 30ns to recover before starting read after WE# rises "H" in case of changing address(es) and CE#="L".
- Once Page Read mode is valid, the mode is kept until RP# is set to VIL or the chip is powered off.
- Word mode(BYTE#=VIH):N=4, Byte mode(BYTE#=VIL):N=8

Byte AC Waveforms for Read Operation

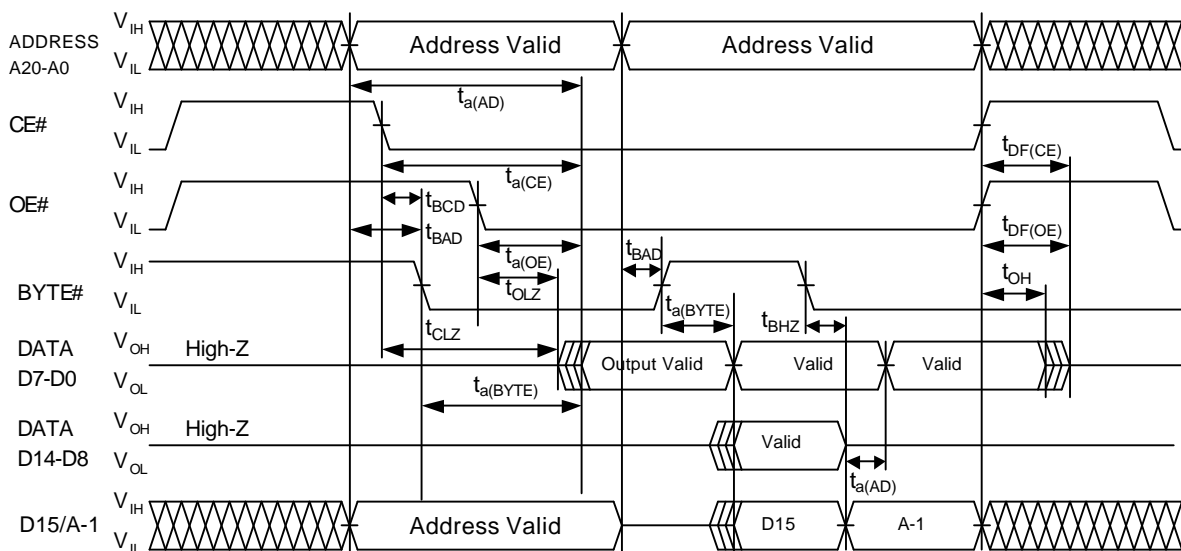

When BYTE# = VIH, CE# = OE# = VIL, D15/A-1 is output status. At this time, input signal must not be applied.

M5M29KB/T331AVP

33,554,432-BIT (4,194,304-WORD BY 8-BIT /2,097,152-WORD BY 16-BIT)
CMOS 3.3V-ONLY, BLOCK ERASE FLASH MEMORY

AC Waveforms for Word / Byte Program Operation (WE# Control)

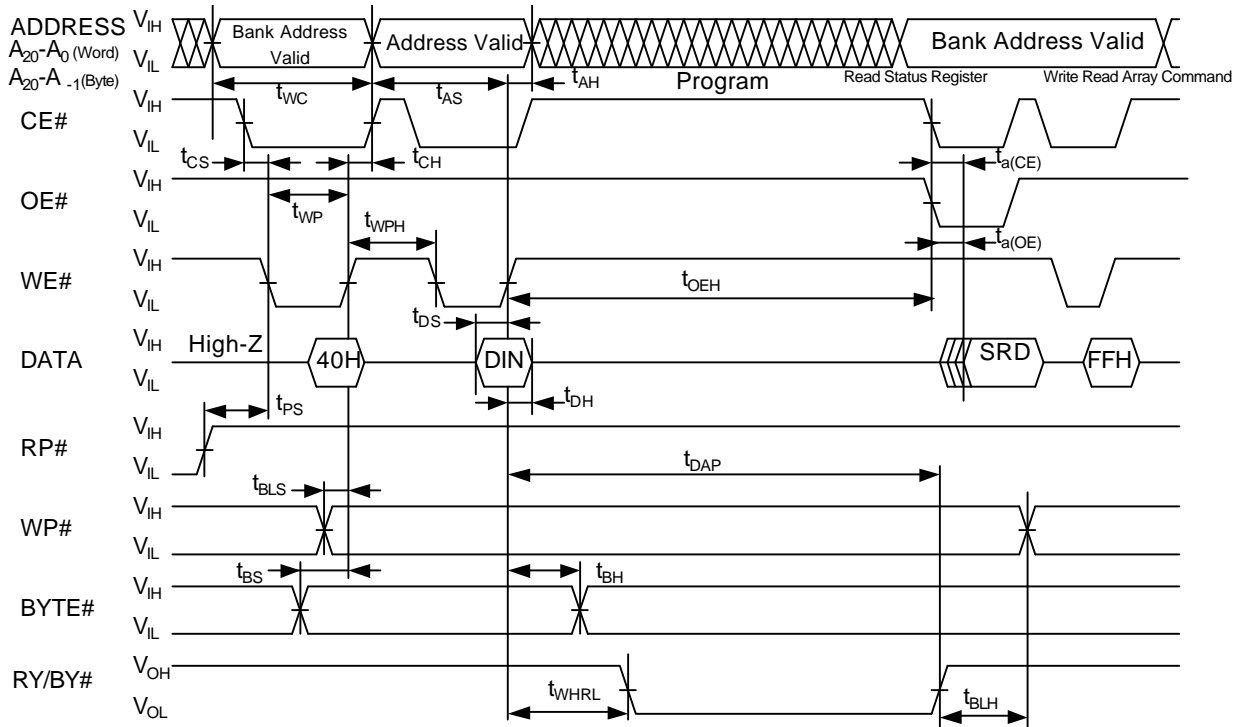

AC Waveforms for Word / Byte Program Operation (CE# Control)

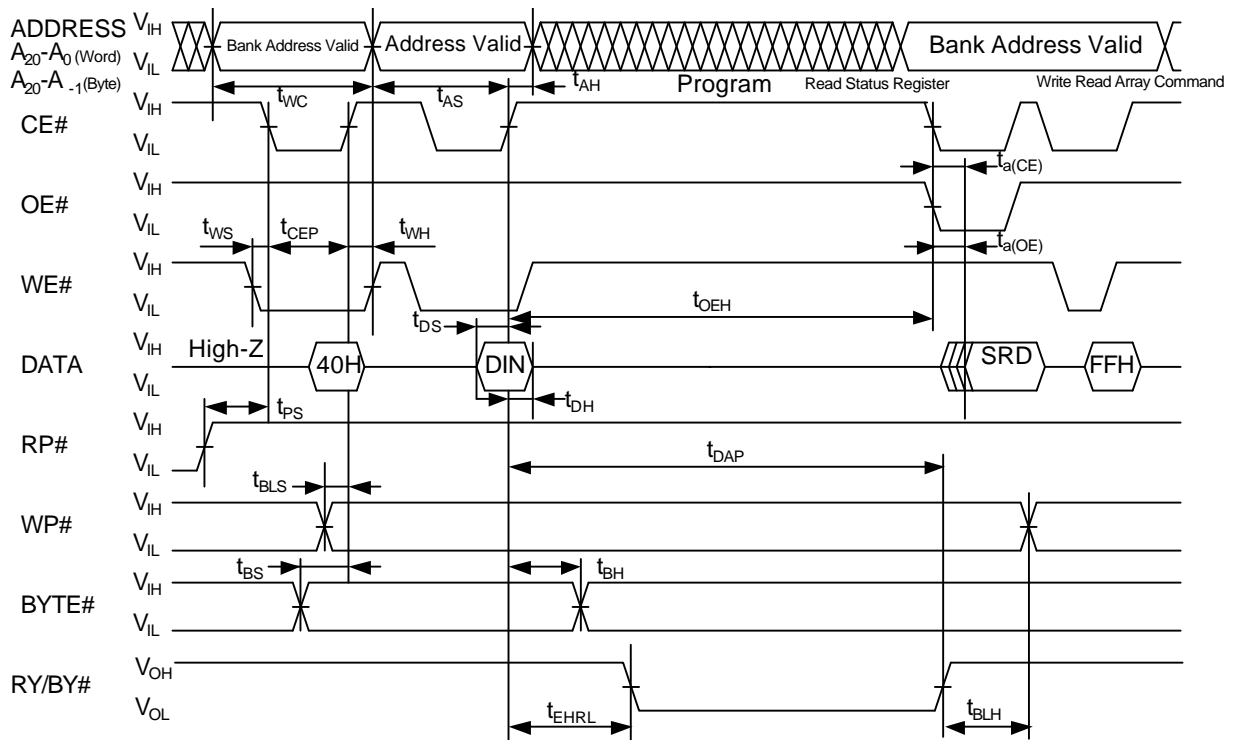

M5M29KB/T331AVP

33,554,432-BIT (4,194,304-WORD BY 8-BIT /2,097,152-WORD BY 16-BIT)
CMOS 3.3V-ONLY, BLOCK ERASE FLASH MEMORY

AC Waveforms for Page Program Operation (WE# Control)

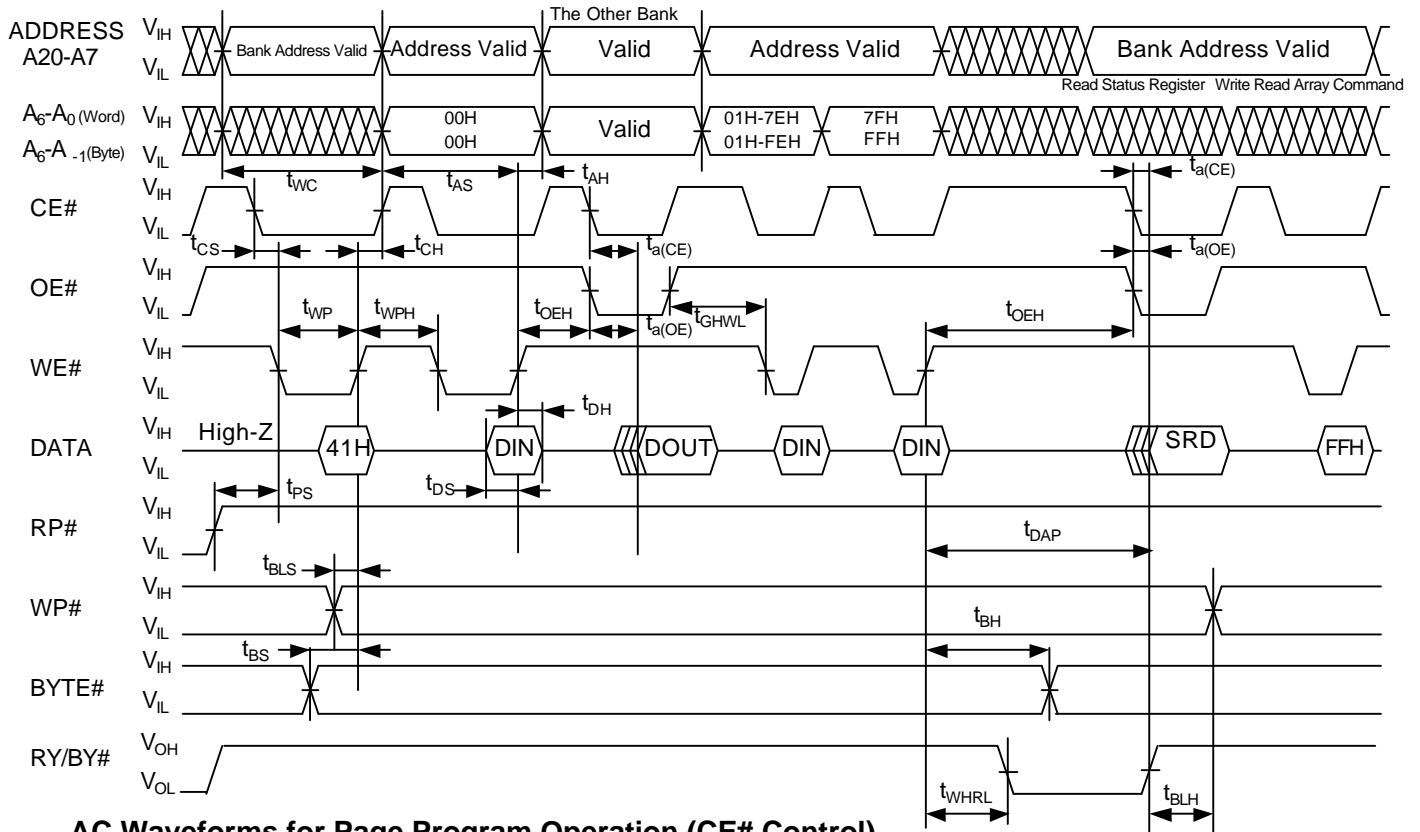

AC Waveforms for Page Program Operation (CE# Control)

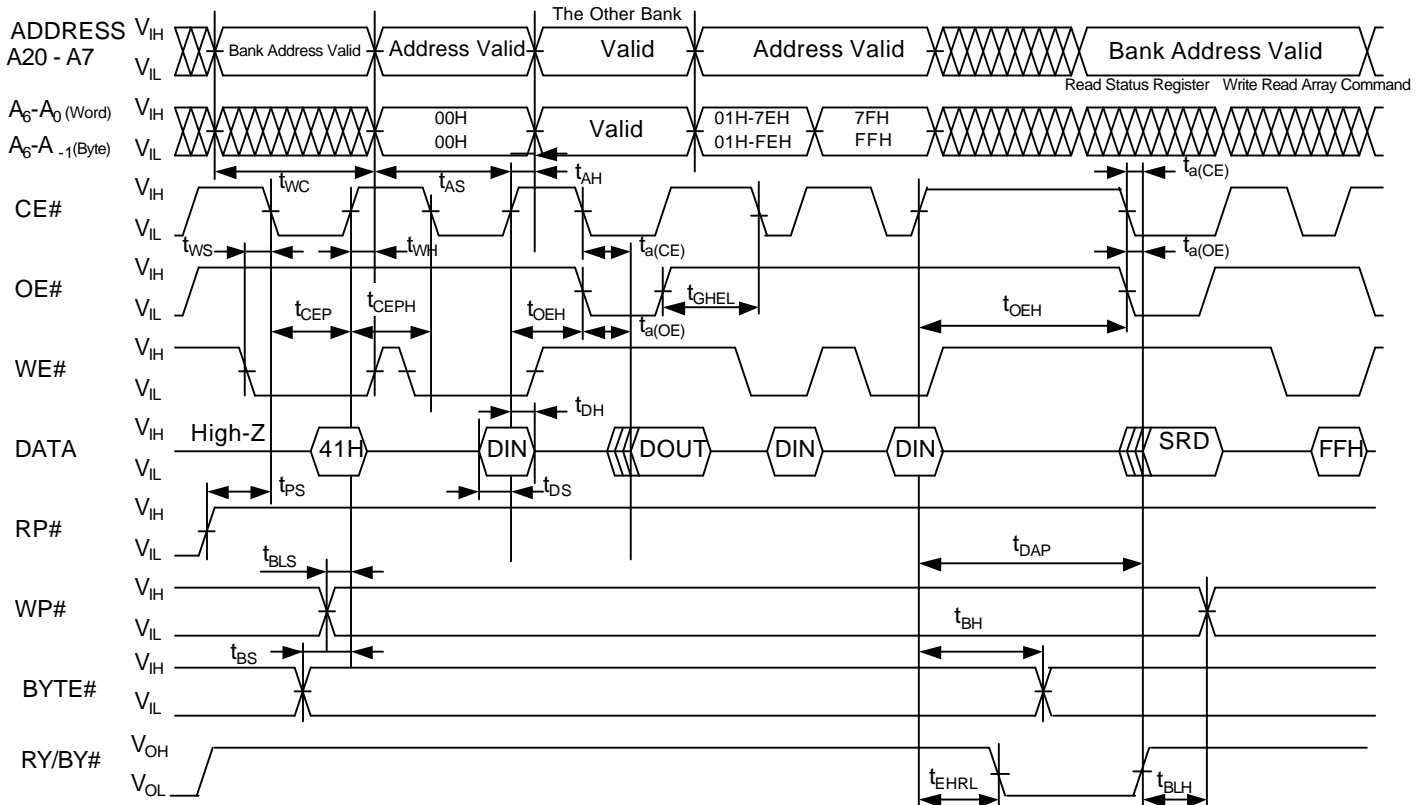

M5M29KB/T331AVP

33,554,432-BIT (4,194,304-WORD BY 8-BIT /2,097,152-WORD BY 16-BIT)
CMOS 3.3V-ONLY, BLOCK ERASE FLASH MEMORY

AC Waveforms for Erase Operation (WE# Control)

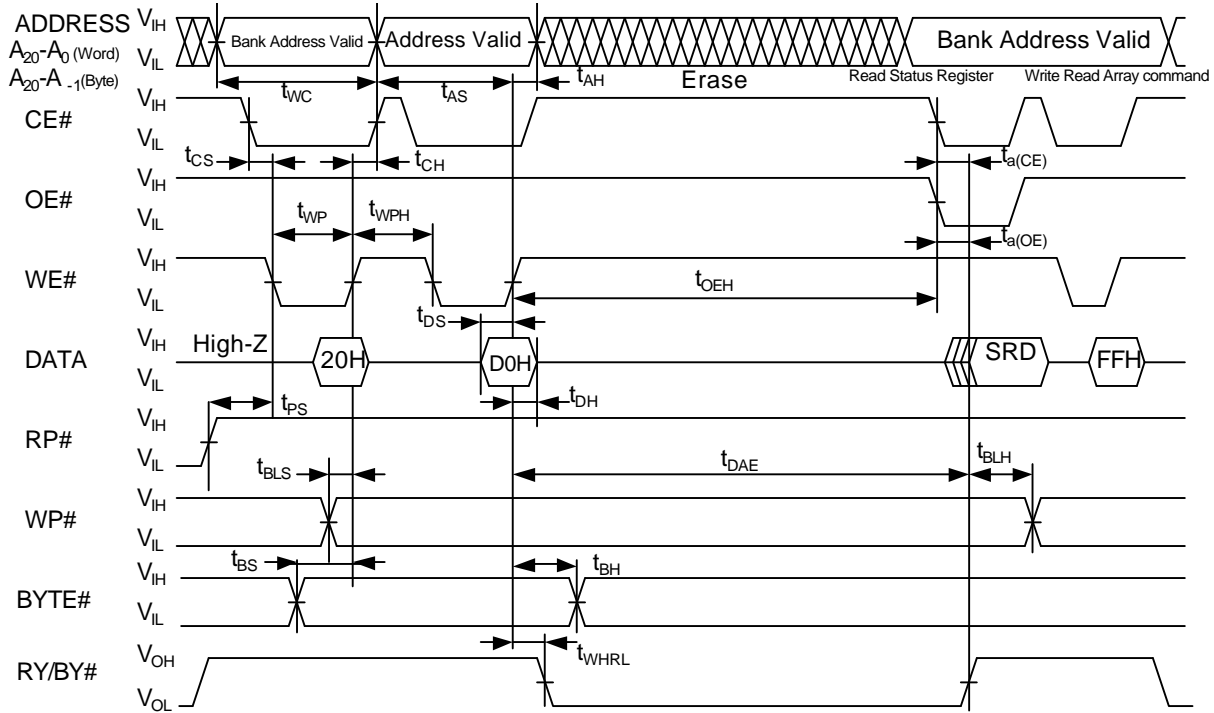

AC Waveforms for Erase Operation (CE# Control)

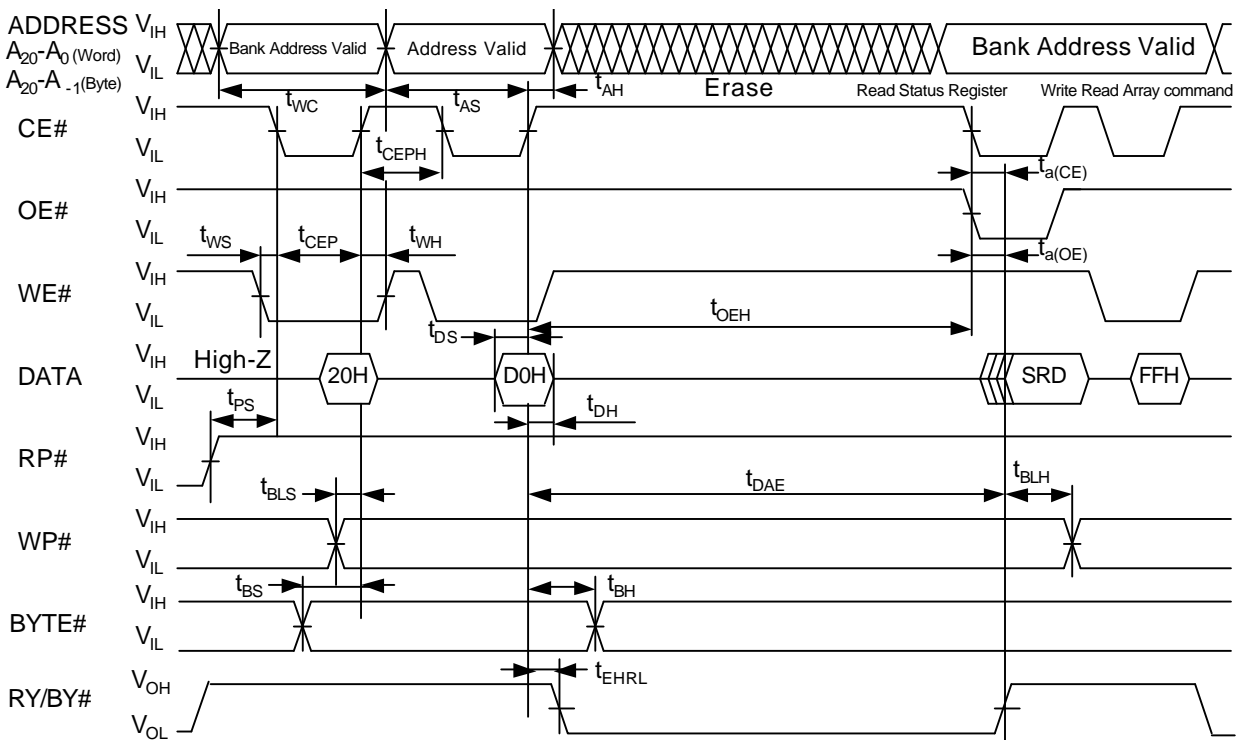

M5M29KB/T331AVP

33,554,432-BIT (4,194,304-WORD BY 8-BIT /2,097,152-WORD BY 16-BIT)
CMOS 3.3V-ONLY, BLOCK ERASE FLASH MEMORY

AC Waveforms for Word / Byte Program Operation with BGO (WE# Control)

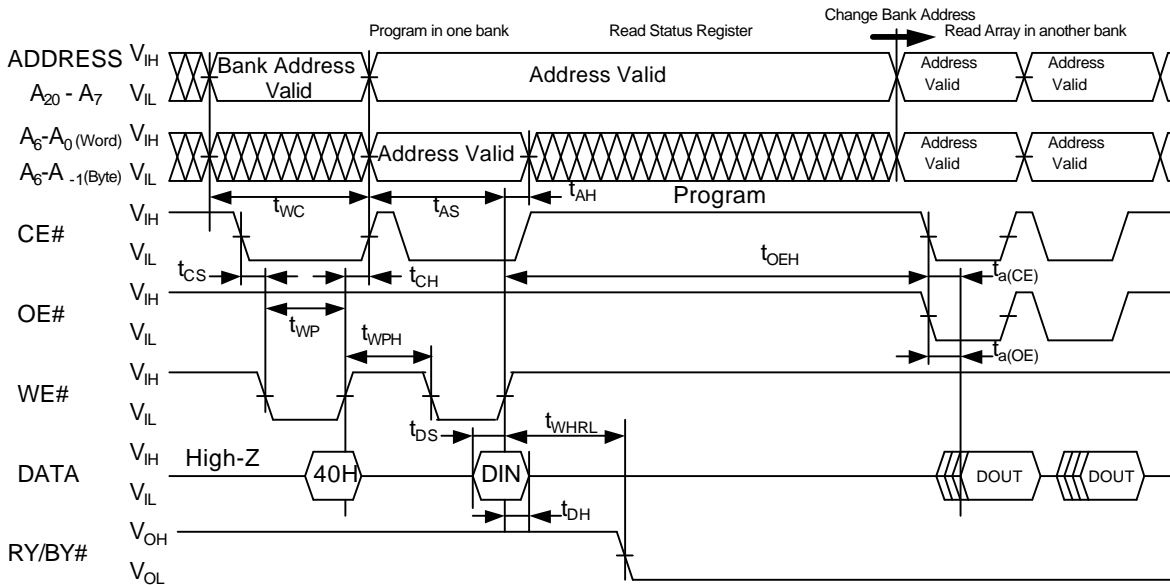

AC Waveforms for Word / Byte Program Operation with BGO (CE# Control)

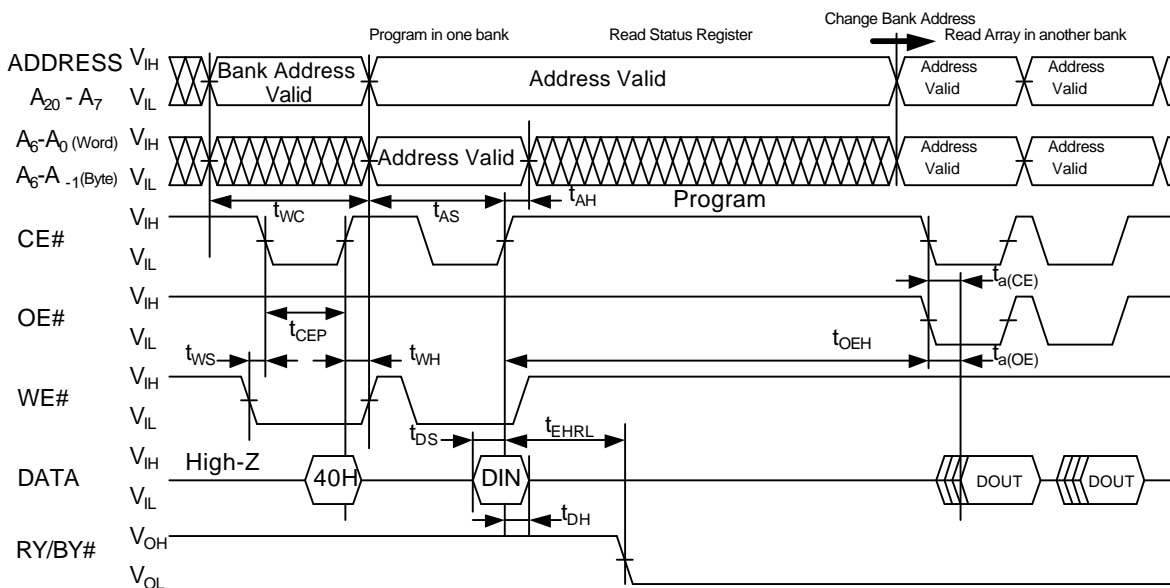

M5M29KB/T331AVP

33,554,432-BIT (4,194,304-WORD BY 8-BIT /2,097,152-WORD BY 16-BIT)
CMOS 3.3V-ONLY, BLOCK ERASE FLASH MEMORY

AC Waveforms for Page Program Operation with BGO (WE# Control)

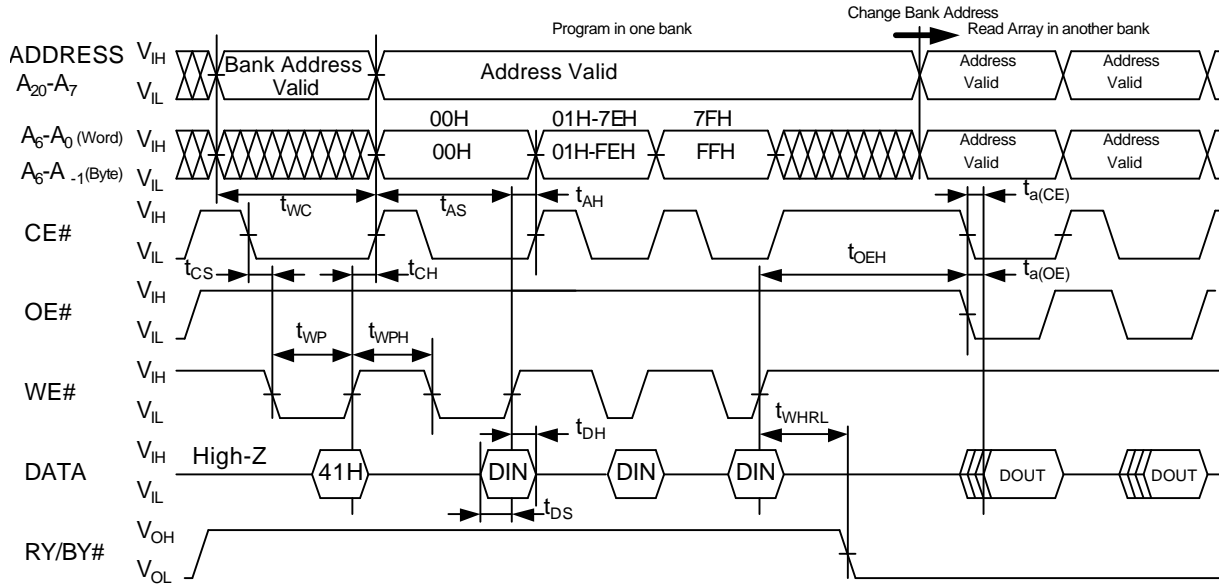

AC Waveforms for Page Program Operation with BGO (CE# Control)

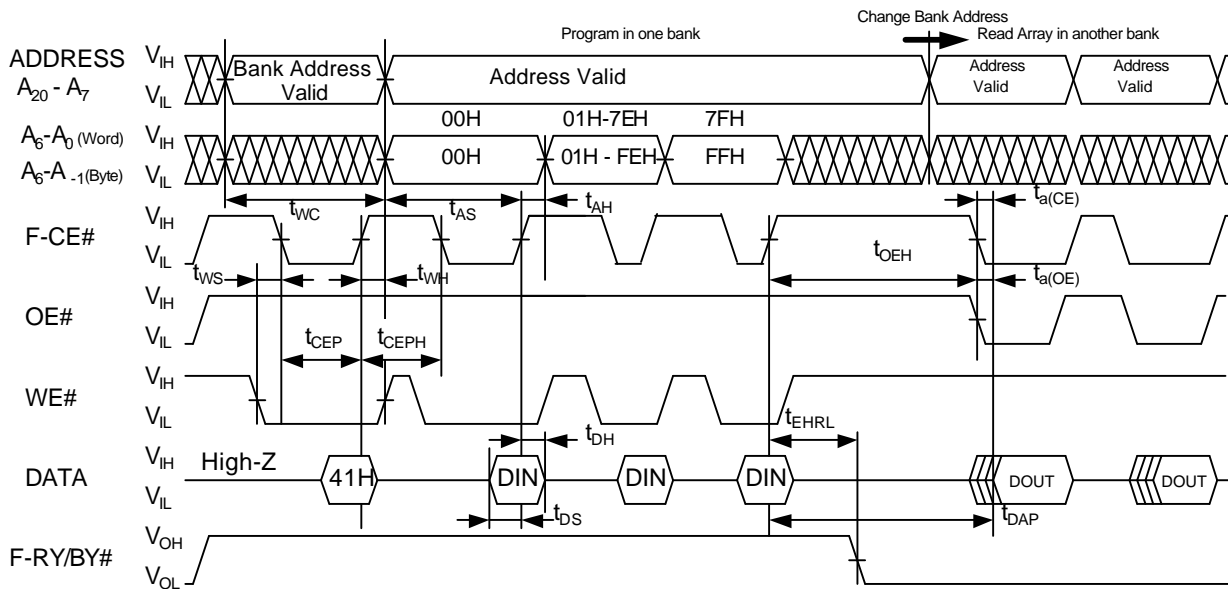

M5M29KB/T331AVP

33,554,432-BIT (4,194,304-WORD BY 8-BIT /2,097,152-WORD BY 16-BIT)
CMOS 3.3V-ONLY, BLOCK ERASE FLASH MEMORY

AC Waveforms for Erase Operation with BGO (WE# Control)

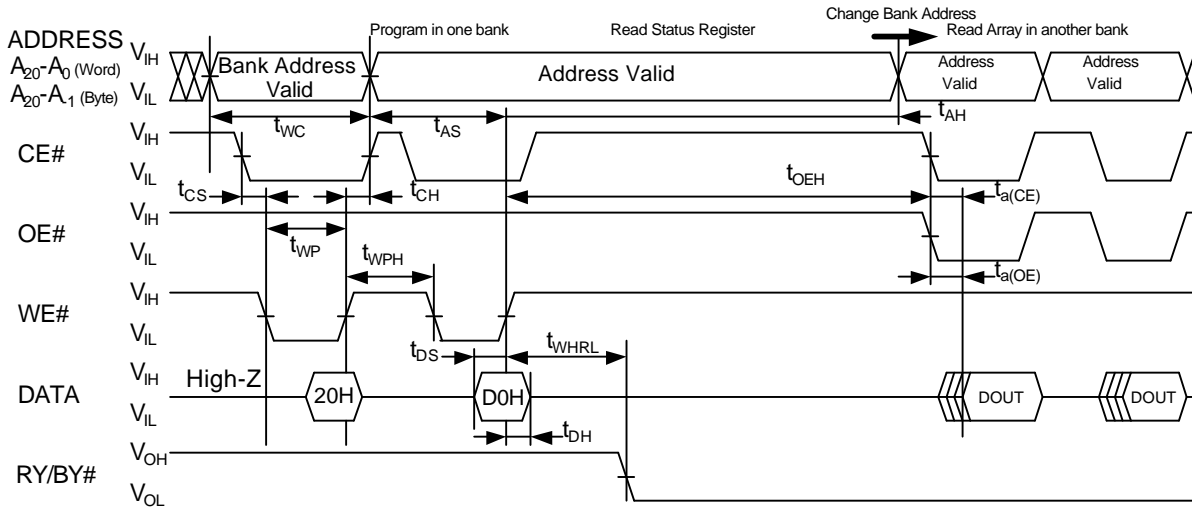

AC Waveforms for Erase Operation with BGO (CE# Control)

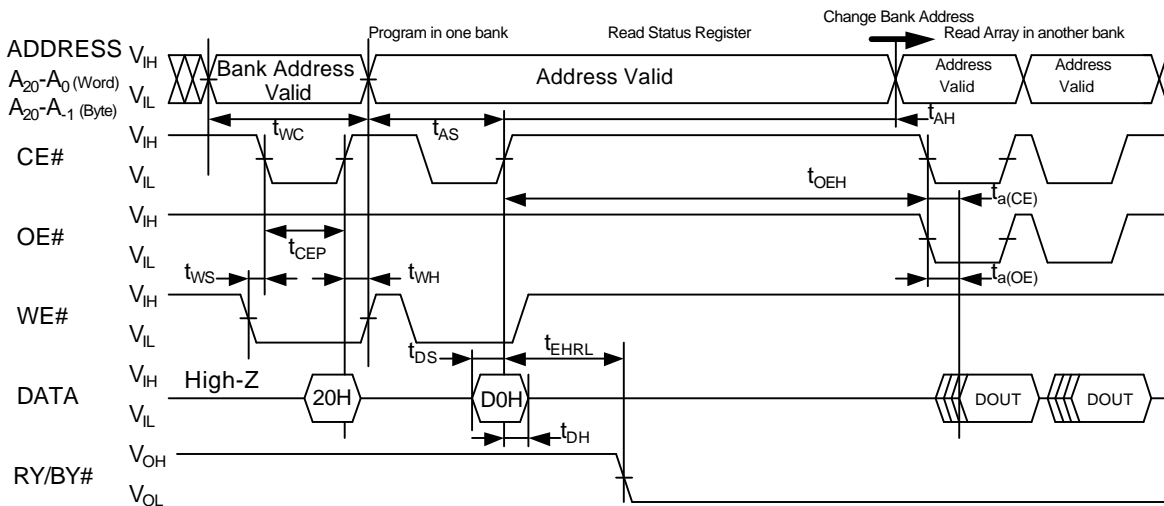

M5M29KB/T331AVP

33,554,432-BIT (4,194,304-WORD BY 8-BIT /2,097,152-WORD BY 16-BIT)
CMOS 3.3V-ONLY, BLOCK ERASE FLASH MEMORY

AC Waveforms for Suspend Operation (WE# Control)

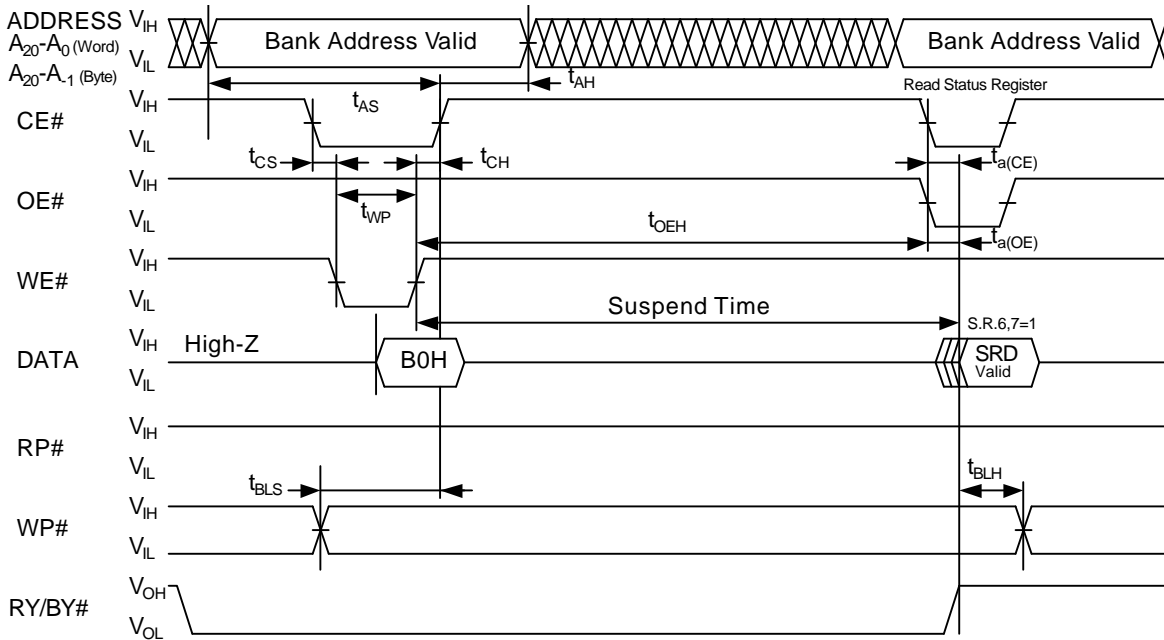

AC Waveforms for Suspend Operation (CE# Control)

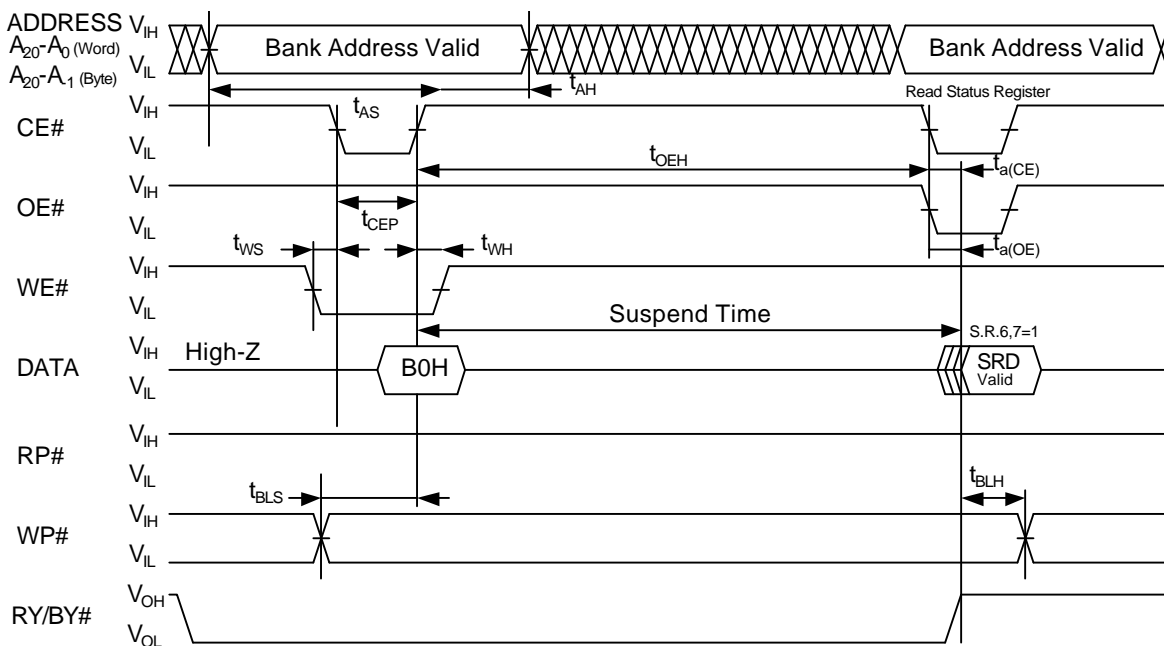

M5M29KB/T331AVP

33,554,432-BIT (4,194,304-WORD BY 8-BIT /2,097,152-WORD BY 16-BIT)
CMOS 3.3V-ONLY, BLOCK ERASE FLASH MEMORY

Word / Byte Program Flow Chart

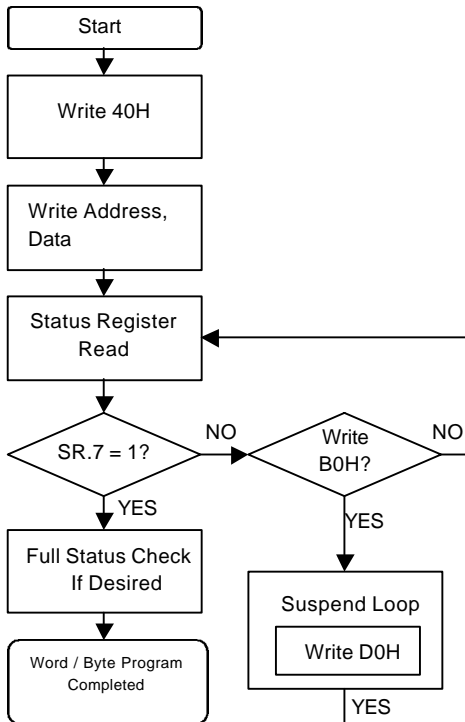

Page Program Flow Chart

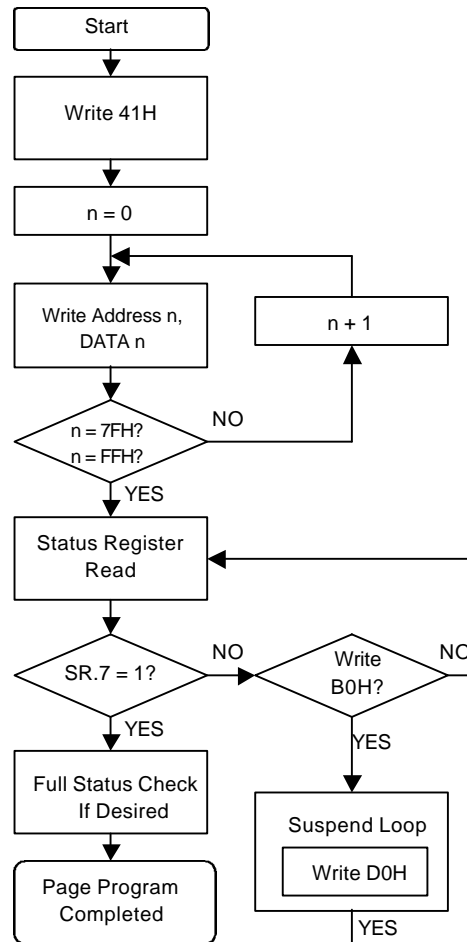

Block Erase Flow Chart

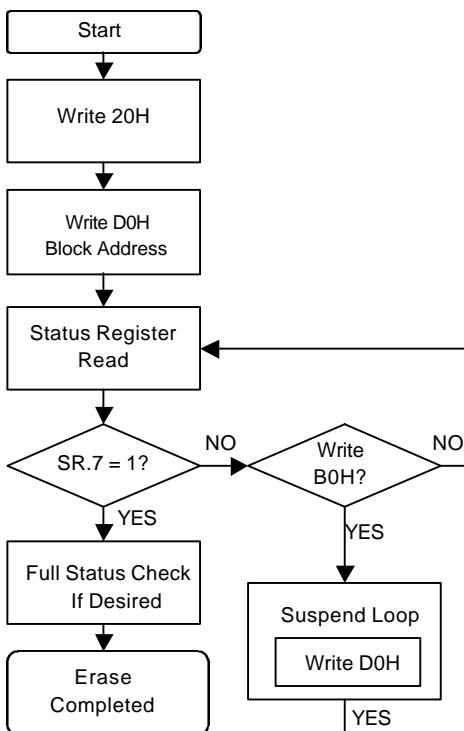

Status Register Check Flow Chart

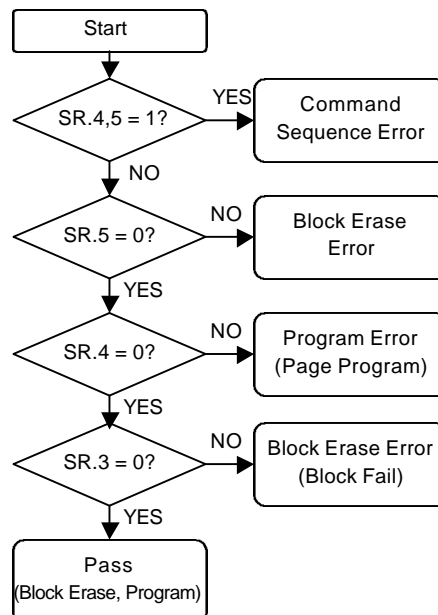

M5M29KB/T331AVP

33,554,432-BIT (4,194,304-WORD BY 8-BIT /2,097,152-WORD BY 16-BIT)
CMOS 3.3V-ONLY, BLOCK ERASE FLASH MEMORY

Single Data Load to Page Buffer Flow Chart

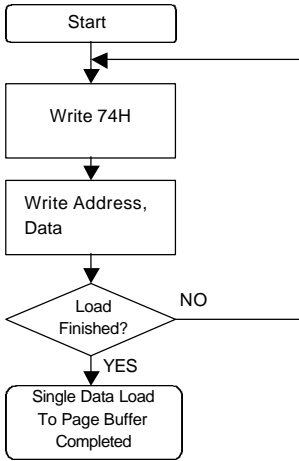

Suspend / Resume Flow Chart

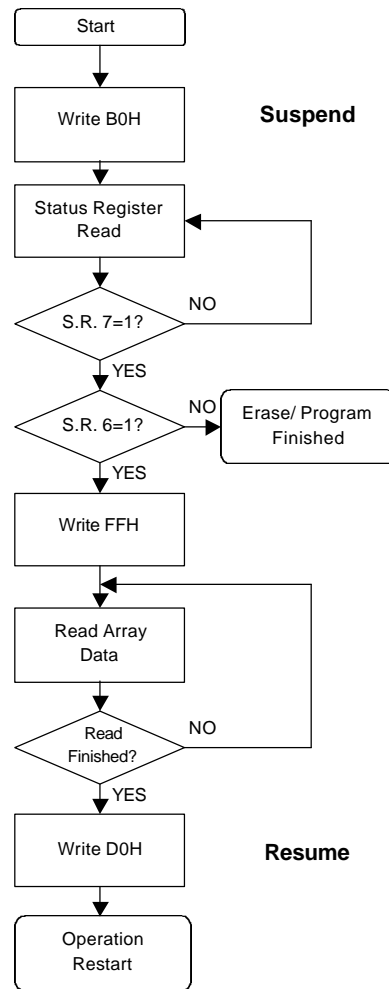

Page Buffer to Flash Flow Chart

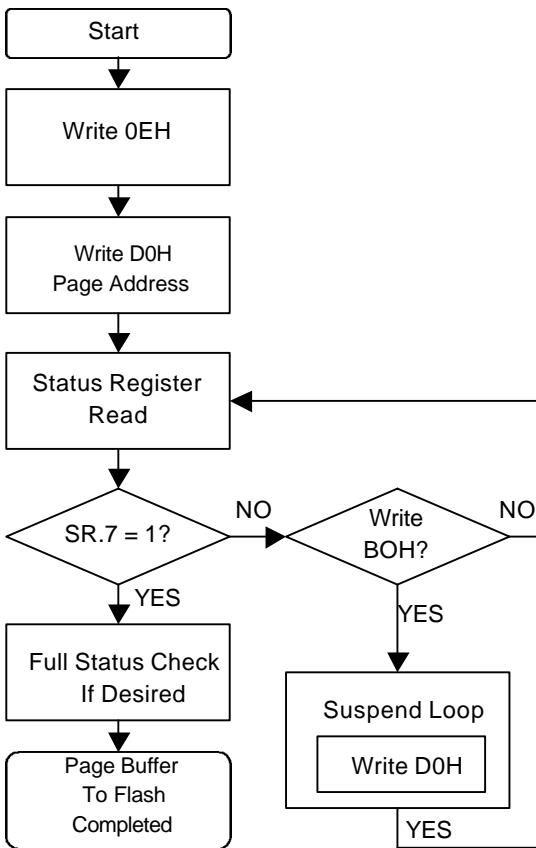

Clear Page Buffer Flow Chart

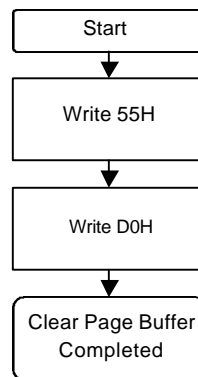

M5M29KB/T331AVP

33,554,432-BIT (4,194,304-WORD BY 8-BIT /2,097,152-WORD BY 16-BIT)
CMOS 3.3V-ONLY, BLOCK ERASE FLASH MEMORY

Operation Status (WP#=VIH)

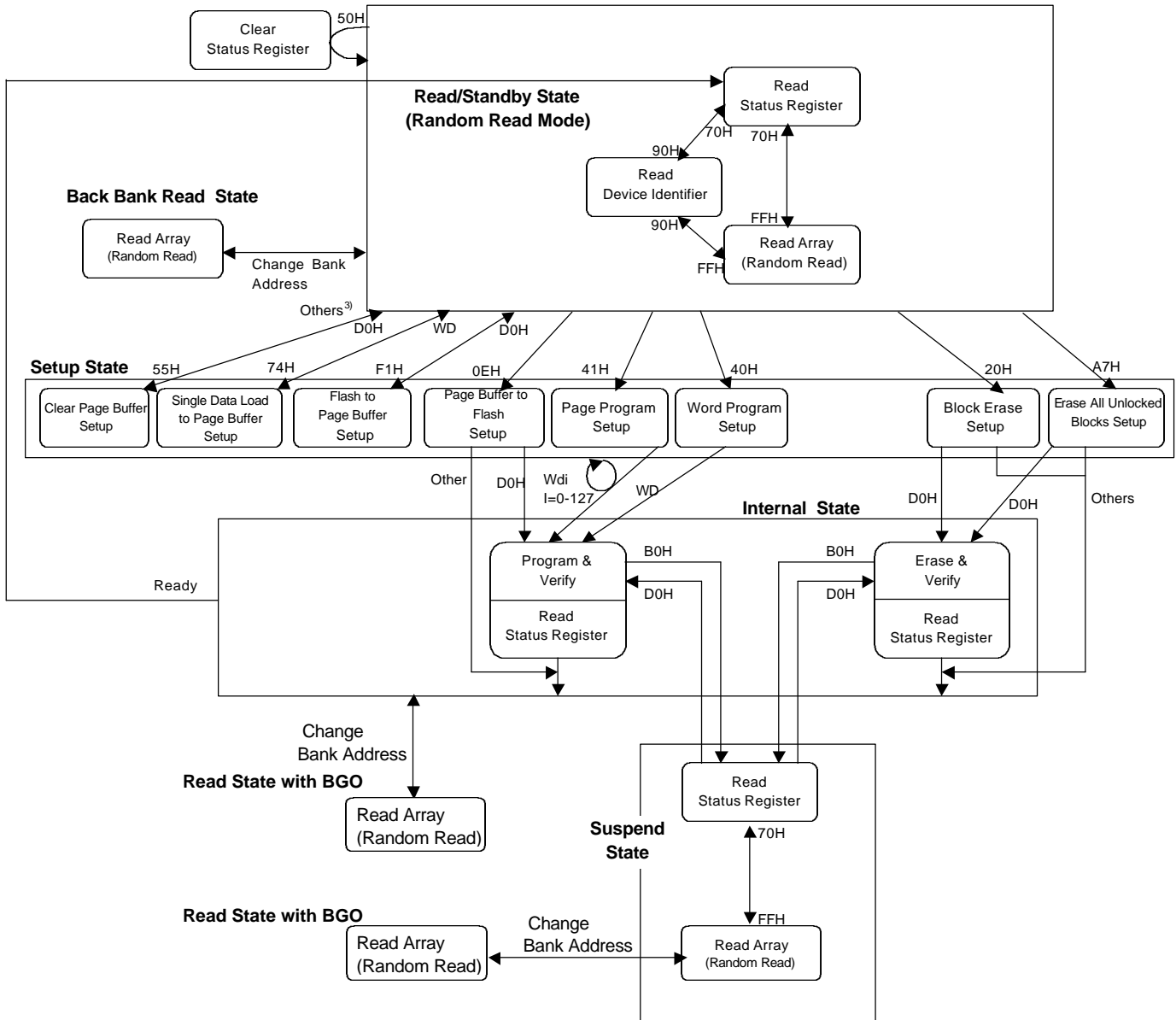

- 1) In case of Page Read, F3H is used instead of FFH in Operation Status (WP#=VIH).
- 2) Once Page Read mode is set, Page Read mode is kept until power off or RP# is set to VIL.
- 3) After setting up Clear Page Buffer, D0H enables to clear Page Buffer.
- 4) To access any bank during Erase All Unlocked Block results Status Register Read.
Although Read Status Register Command and Read Array Command can be issued under Suspend State, output data make no sense.

M5M29KB/T331AVP

33,554,432-BIT (4,194,304-WORD BY 8-BIT /2,097,152-WORD BY 16-BIT)
CMOS 3.3V-ONLY, BLOCK ERASE FLASH MEMORY

Operation Status (WP#=VIL)

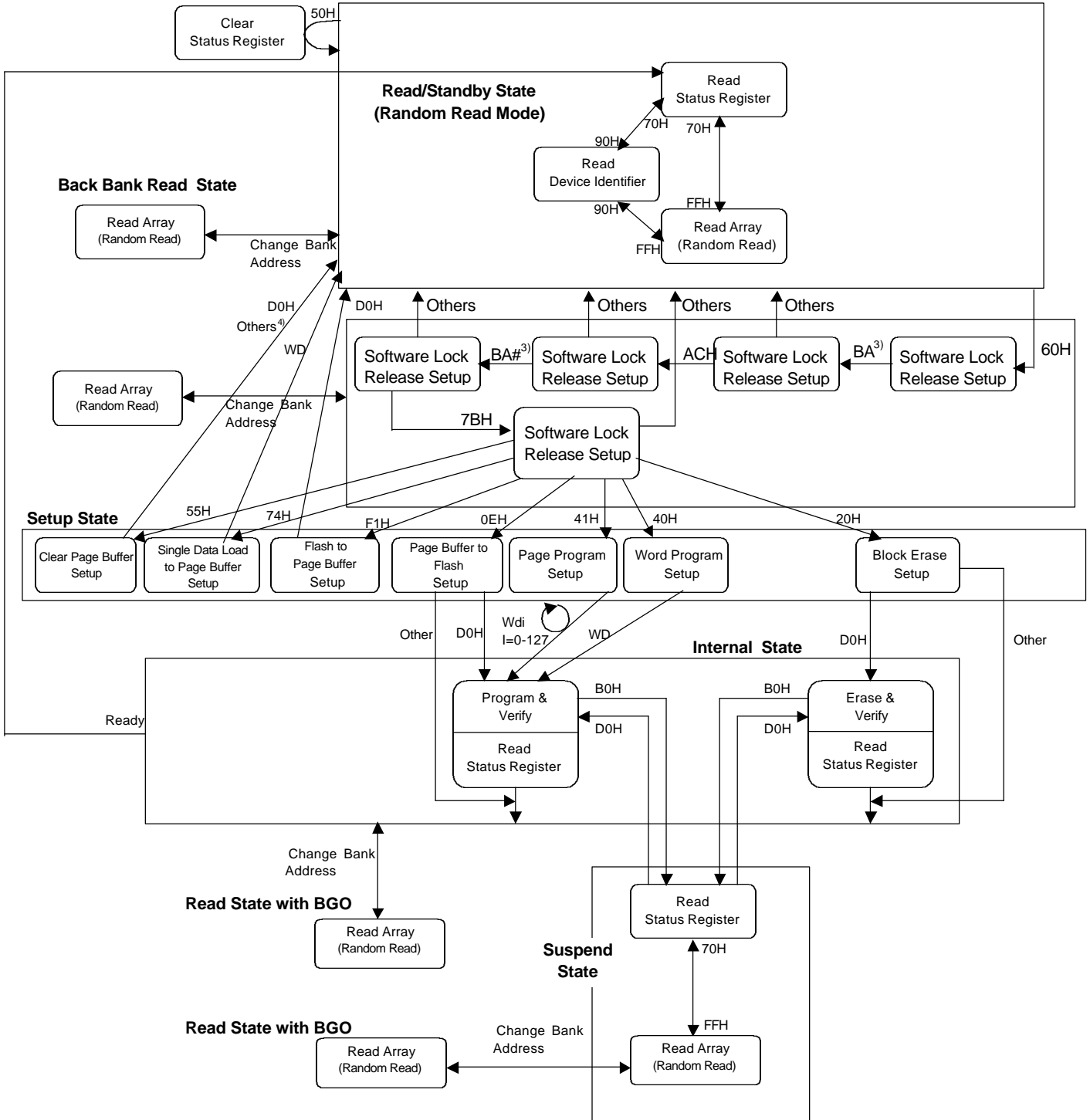

- 1) In case of Page Read, F3H is used instead of FFH in Operation Status (WP#=VIL).
- 2) Once Page Read mode is set, Page Read mode is kept until power off or RP# is set to VIL.
- 3) BA, BA#: Block Address, Block Address# (Shown in Command List(WP#=VIL) in detail).
- 4) After setting up Clear Page Buffer, D0H enables to clear Page Buffer.

M5M29KB/T331AVP

33,554,432-BIT (4,194,304-WORD BY 8-BIT /2,097,152-WORD BY 16-BIT)
CMOS 3.3V-ONLY, BLOCK ERASE FLASH MEMORY

Package Dimension

48P3R-C

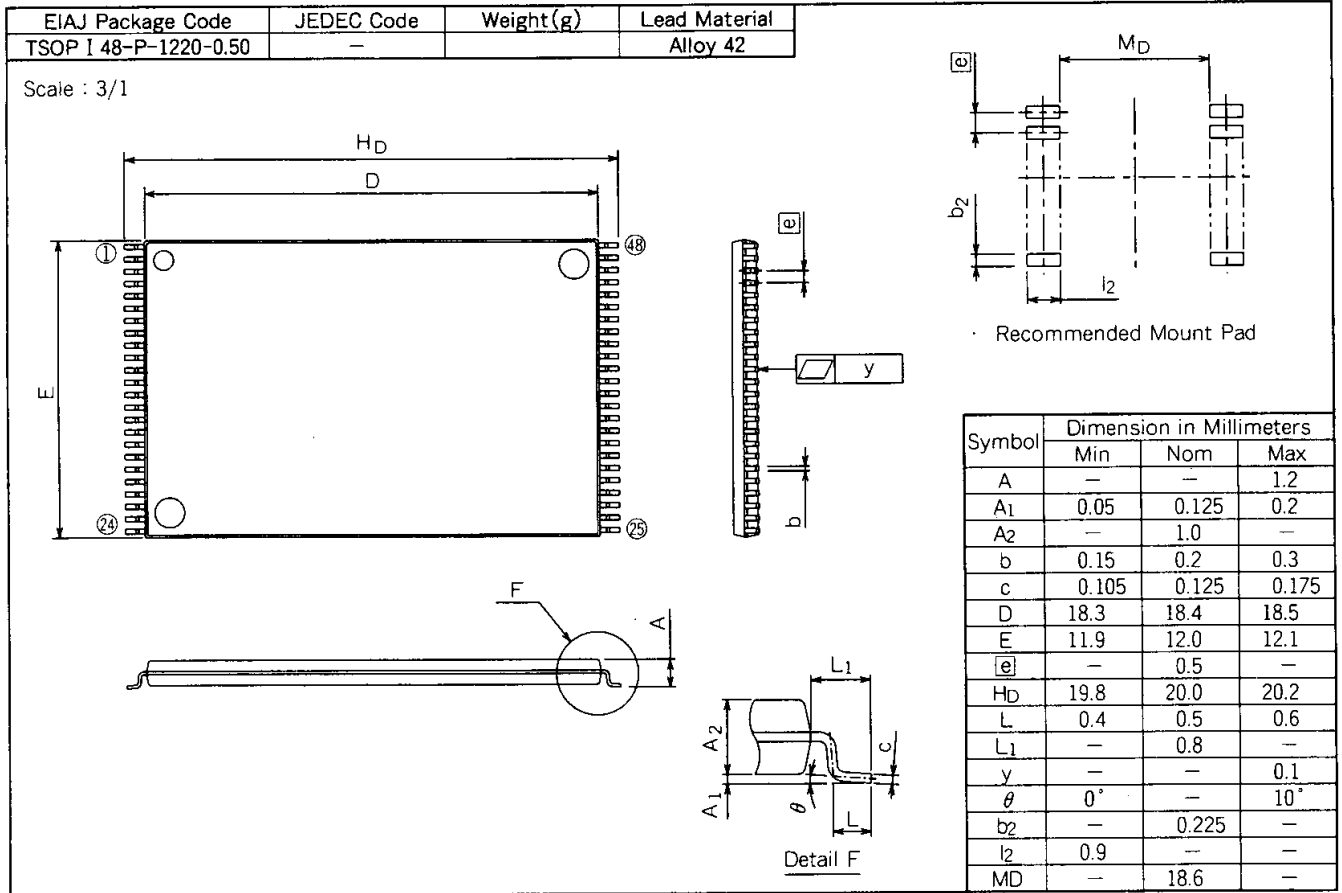

M5M29KB/T331AVP

33,554,432-BIT (4,194,304-WORD BY 8-BIT /2,097,152-WORD BY 16-BIT)
CMOS 3.3V-ONLY, BLOCK ERASE FLASH MEMORY

Renesas Technology Corp.

Nippon Bldg.,6-2,Otemachi 2-chome,Chiyoda-ku,Tokyo,100-0004 Japan

Keep safety first in your circuit designs!

- Renesas Technology Corporation puts the maximum effort into making semiconductor products better and more reliable, but there is always the possibility that trouble may occur with them. Trouble with semiconductors may lead to personal injury, fire or property damage. Remember to give due consideration to safety when making your circuit designs, with appropriate measures such as (i) placement of substitutive, auxiliary circuits, (ii) use of nonflammable material or (iii) prevention against any malfunction or mishap.

Notes regarding these materials

- These materials are intended as a reference to assist our customers in the selection of the Renesas Technology Corporation product best suited to the customer's application; they do not convey any license under any intellectual property rights, or any other rights, belonging to Renesas Technology Corporation or a third party.
- Renesas Technology Corporation assumes no responsibility for any damage, or infringement of any third-party's rights, originating in the use of any product data, diagrams, charts, programs, algorithms, or circuit application examples contained in these materials.
- All information contained in these materials, including product data, diagrams, charts, programs and algorithms represents information on products at the time of publication of these materials, and are subject to change by Renesas Technology Corporation without notice due to product improvements or other reasons. It is therefore recommended that customers contact Renesas Technology Corporation or an authorized Renesas Technology Corporation product distributor for the latest product information before purchasing a product listed herein.
The information described here may contain technical inaccuracies or typographical errors.
Renesas Technology Corporation assumes no responsibility for any damage, liability, or other loss rising from these inaccuracies or errors.
Please also pay attention to information published by Renesas Technology Corporation by various means, including the Renesas Technology Corporation Semiconductor home page (<http://www.renesas.com>).
- When using any or all of the information contained in these materials, including product data, diagrams, charts, programs, and algorithms, please be sure to evaluate all information as a total system before making a final decision on the applicability of the information and products. Renesas Technology Corporation assumes no responsibility for any damage, liability or other loss resulting from the information contained herein.
- Renesas Technology Corporation semiconductors are not designed or manufactured for use in a device or system that is used under circumstances in which human life is potentially at stake. Please contact Renesas Technology Corporation or an authorized Renesas Technology Corporation product distributor when considering the use of a product contained herein for any specific purposes, such as apparatus or systems for transportation, vehicular, medical, aerospace, nuclear, or undersea repeater use.
- The prior written approval of Renesas Technology Corporation is necessary to reprint or reproduce in whole or in part these materials.
- If these products or technologies are subject to the Japanese export control restrictions, they must be exported under a license from the Japanese government and cannot be imported into a country other than the approved destination.
- Any diversion or reexport contrary to the export control laws and regulations of Japan and/or the country of destination is prohibited.
- Please contact Renesas Technology Corporation for further details on these materials or the products contained therein.