

# 2SC5418

## Silicon NPN triple diffusion mesa type

For horizontal deflection output

### Features

- High breakdown voltage, and high reliability through the use of a glass passivation layer
- High-speed switching
- Wide area of safe operation (ASO)

### Absolute Maximum Ratings ( $T_C=25^\circ\text{C}$ )

Parameter	Symbol	Rated	Unit	
Collector to base voltage	$V_{CBO}$	1700	V	
Collector to emitter voltage	$V_{CES}$	1700	V	
	$V_{CEO}$	600	V	
Emitter to base voltage	$V_{EBO}$	5	V	
Peak collector current	$I_{CP}$	30	A	
Collector current	$I_C$	20	A	
Base current	$I_B$	10	A	
Collector power dissipation	$P_C$	$T_C=25^\circ\text{C}$	100	W
		$T_a=25^\circ\text{C}$	3.5	
Junction temperature	$T_j$	150	$^\circ\text{C}$	
Storage temperature	$T_{stg}$	-55 to +150	$^\circ\text{C}$	

### Electrical Characteristics ( $T_C=25^\circ\text{C}$ )

Parameter	Symbol	Conditions	min	typ	max	Unit
Collector cutoff current	$I_{CBO}$	$V_{CB} = 1000\text{V}, I_E = 0$			50	$\mu\text{A}$
		$V_{CB} = 1700\text{V}, I_E = 0$			1	mA
Emitter cutoff current	$I_{EBO}$	$V_{EB} = 5\text{V}, I_C = 0$			50	$\mu\text{A}$
Forward current transfer ratio	$h_{FE}$	$V_{CE} = 5\text{V}, I_C = 10\text{A}$	7		14	
Collector to emitter saturation voltage	$V_{CE(sat)}$	$I_C = 10\text{A}, I_B = 2.8\text{A}$			3	V
Base to emitter saturation voltage	$V_{BE(sat)}$	$I_C = 10\text{A}, I_B = 2.8\text{A}$			1.5	V
Transition frequency	$f_T$	$V_{CE} = 10\text{V}, I_C = 0.1\text{A}, f = 0.5\text{MHz}$		3		MHz
Storage time	$t_{stg}$	$I_C = 12\text{A}, I_{B1} = 2.4\text{A}, I_{B2} = -4.8\text{A}$			4.0	$\mu\text{s}$
Fall time	$t_f$				0.3	$\mu\text{s}$

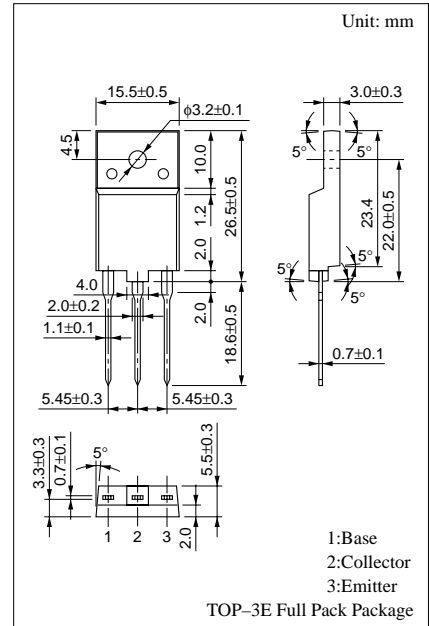

$P_C - T_a$

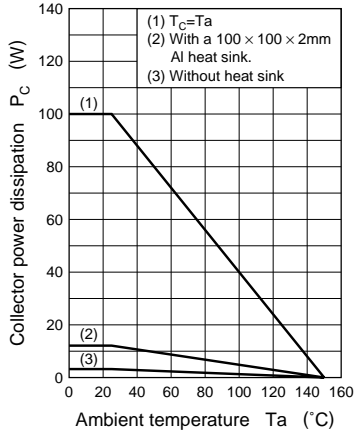

Area of safe operation (ASO)

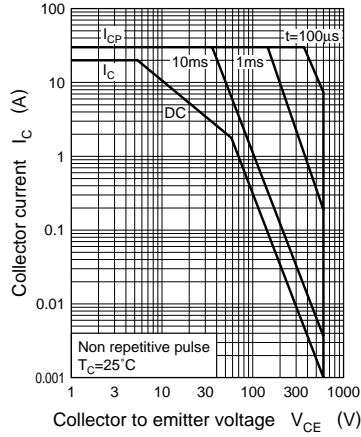

Area of safe operation, horizontal operation ASO

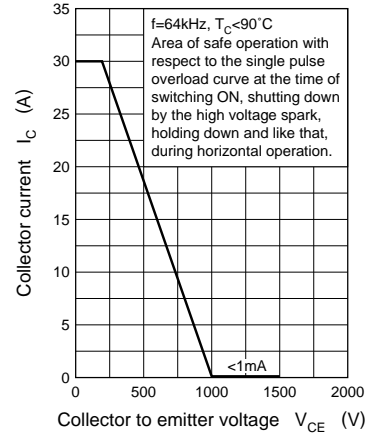

This datasheet has been downloaded from:

[www.DatasheetCatalog.com](http://www.DatasheetCatalog.com)

Datasheets for electronic components.