

VICOR CONFIDENTIAL

THIS DOCUMENT AND THE DATA DISCLOSED HEREIN OR HEREWITH IS NOT TO BE REPRODUCED, USED, OR DISCLOSED IN WHOLE OR IN PART TO ANYONE WITHOUT PERMISSION OF VICOR CORP.

REV.	DESCRIPTION	DATE	APPROVED
01	RELSD- E960407	RCM 9/14/96	DPK

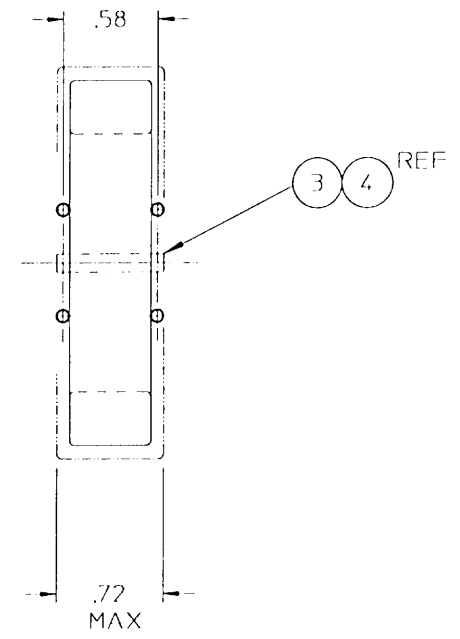
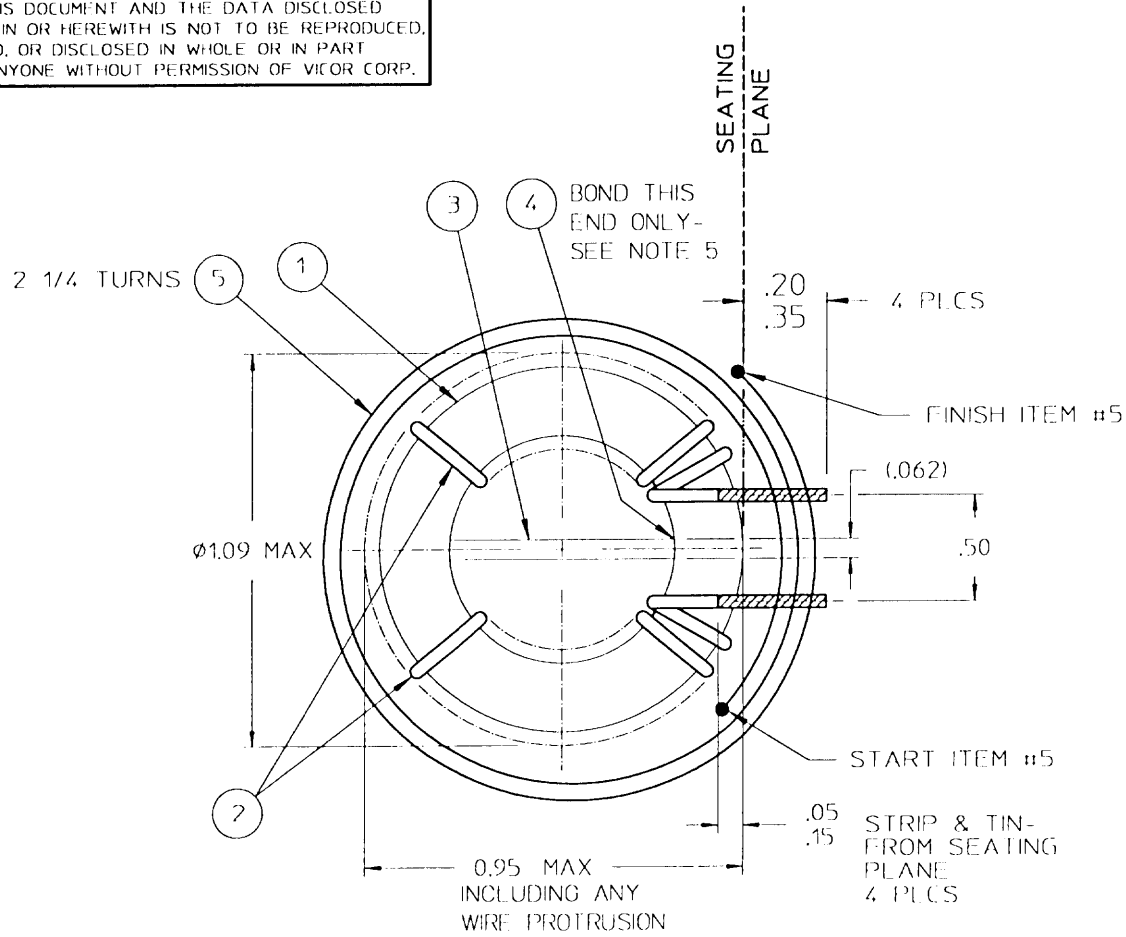

NOTES

- SEE BOM 15016 FOR LIST OF PARTS
- MAGNET WIRE: CLASS 130°C NEMA MW1000, NEMA MW28-C
- UL/CSA/VDE APPROVABLE, 2K VDC ISO WINDING TO WINDING
- ASSEMBLY TO BE FREE OF NICKS
- BOND SPACER (ITEM 3) TO CORE (ITEM 1) USING ADHESIVE (ITEM 4) OF EQUIVALENT- ONE END ONLY

UNLESS OTHERWISE SPECIFIED DIMENSIONS ARE IN INCHES. TOLERANCES ARE:
 FRACTIONS DECIMALS ANGLES
 ± 1/64 .XX ± .01 ± 1°
 .XXX ± .005

APPROVALS	DATE
	8/96



ASSEMBLY DRAWING
 CM CHOKE W/ TAPE

TEST	ITEM NO.	NO. OF TURNS	IND. (Ω)	DC RES (m Ω)
10 KHZ @ 10mV RMS	2	19 EACH SIDE	2180 ±20%	14.0 MAX

THIRD ANGLE PROJECTION

 DO NOT SCALE DRAWING

Part # 15016	SIZE	SCM NO.	DWG. NO.	REV.
	B	67131	15017	01
SCALE: NONE			SHEET 1 OF 1	