

# MN6311S

## 2K-Bit EEPROM

### ■ Overview

The MN6311S is a 2048-bit, bit sequential EEPROM with a built-in address counter. It sequentially increments the address with the clock input to produce serial output.

It includes a built-in charge pump circuit and timer for automatically erasing, writing, and modifying data using only a single 3 volt power supply.

To reduce write times, it includes a block write function for writing up to 32 bits at a time. This function makes it possible to rewrite the contents of all 2048 bits within 1 second (typ.).

### ■ Features

- 2048 words × 1 bit organization
- Built-in reset function
- Tristate output
- Low power consumption
  - 3 volt read: 1.5 mW (max.)
  - 3 volt program: 6 mW (max.)
  - 3 volt standby: 60 μW (max.)
- Single 3 volt power supply (charge pump circuit built-in)
- Self timer for use in automatically erasing and writing data
- Built-in data polling function
- Write cycles: 10<sup>5</sup> times
- Data storage interval: 10 years

### ■ Applications

- Personal wireless equipment, cordless telephones, storage for recognition and adjustment data for terminals, etc.

### ■ Pin Assignment

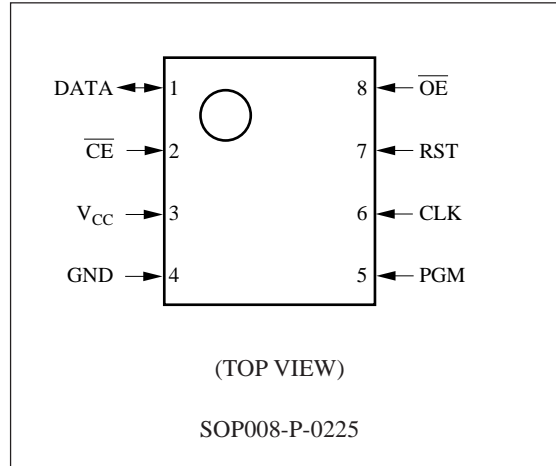

■ Block Diagram

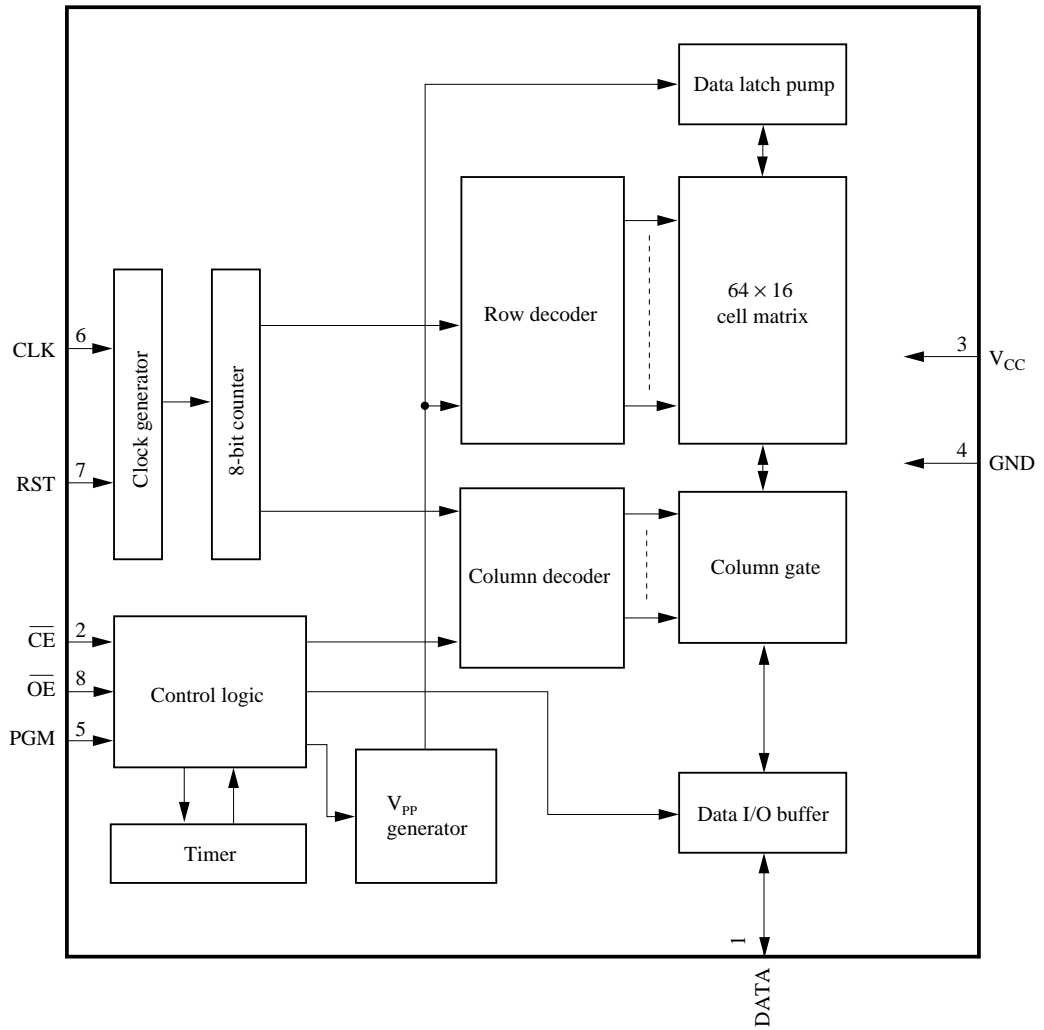

### ■ Pin Descriptions

Pin No.	Symbol	Pin Name
1	DATA	Data I/O
2	$\overline{\text{CE}}$	Chip enable
3	$V_{\text{CC}}$	Power supply voltage
4	GND	Ground
5	PGM	Program
6	CLK	Clock input
7	RST	Reset input
8	OE	Output enable

### ■ Electrical Characteristics

$V_{\text{CC}}=2.6$  to  $3.5\text{V}$ ,  $T_a=-10^\circ\text{C}$  to  $+60^\circ\text{C}$

Parameter	Symbol	Test Conditions	3 Volt Operation		Unit
			min	max	
Power supply voltage	$V_{\text{CC}}$	Read mode	2.6	3.5	V
		Program mode	3.0	3.5	
"L" level input leakage current	$I_{\text{LIL}}$	$\overline{\text{CE}}$ pin	-50	—	$\mu\text{A}$
		Other pins	-10	10	
"H" level input leakage current	$I_{\text{LIH}}$	PGM, CLK, and RST pins	—	-20	$\mu\text{A}$
		Other pins	-10	10	
Output leakage current	$I_{\text{LO}}$		—	10	$\mu\text{A}$
"L" level input voltage	$V_{\text{IL}}$		-0.1 $V_{\text{CC}}$	0.2	V
"H" level input voltage	$V_{\text{IH}}$		0.8 $V_{\text{CC}}$	$V_{\text{CC}}$ +0.3	V
$V_{\text{CC}}$ power supply current (during operation)	$I_{\text{CC}}$	Read mode CLK;f=250kHz	—	500	$\mu\text{A}$
		Program mode	—	2000	
$V_{\text{CC}}$ power supply current (during standby)	$I_{\text{SB}}$	$\overline{\text{CE}} = V_{\text{CC}} + 0.3\text{V}$ ; RST and PGM pins at $V_{\text{CC}}$ ; CLK pin open	—	20	$\mu\text{A}$
"L" level output voltage	$V_{\text{OL}}$	$I_{\text{OL}}=400\ \mu\text{A}$	—	0.3	V
"H" level output voltage	$V_{\text{OH}}$	$I_{\text{OH}}=10\ \mu\text{A}$	$V_{\text{CC}}$ -0.3	—	V

## ■ Function Descriptions

### Operating Modes

Pin Symbol (Pin No.)	$\overline{\text{CE}}$ (2)	$\overline{\text{OE}}$ (8)	PGM (5)	DATA (1)
Operating Mode				
Read	$V_{\text{IL}}$	$V_{\text{IL}}$	×	$D_{\text{OUT}}$
Standby	$V_{\text{IH}}$	×	×	High-impedance
Program	$V_{\text{IL}}$	$V_{\text{IH}}$		$D_{\text{IN}}$

## ■ Package Dimensions (Unit:mm)

SOP008-P-0225

