

MAZS000 Series

Silicon planar type

For constant voltage, constant-current, waveform clipper and surge absorption circuit

■ Features

- SS-mini type 2-pin package
- Low noise type
- V_Z rank classified ($V_Z = 2.4\text{ V to }39\text{ V}$)

■ Absolute Maximum Ratings $T_a = 25^\circ\text{C}$

Parameter	Symbol	Rating	Unit
Instantaneous forward current	I_{FRM}	200	mA
Total power dissipation*	P_{tot}	150	mW
Junction temperature	T_j	150	$^\circ\text{C}$
Storage temperature	T_{stg}	-55 to +150	$^\circ\text{C}$

Note) * : With a printed-circuit board

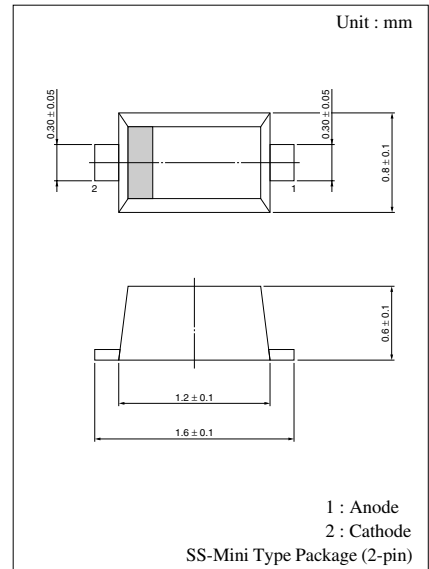

Marking Symbol

Refer to the list of the electrical characteristics within part numbers

(Example) MAZS082 : 8
 MAZS0820L : 8_
 MAZS0820M : 8-
 MAZS0820H : 8^

Note) L/M/H marked products will be supplied unless other wise specified

Internal Connection

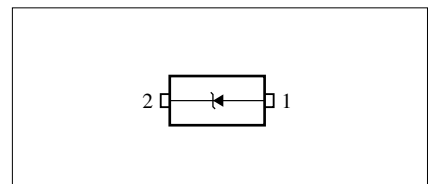

■ Common Electrical Characteristics $T_a = 25^\circ\text{C}^{*1}$

Parameter	Symbol	Conditions	Min	Typ	Max	Unit
Forward voltage	V_F	$I_F = 10\text{ mA}$		0.9	1.0	V
Zener voltage ^{*2}	V_Z	I_Z Specified value	Refer to the list of the electrical characteristics within part numbers			V
Operating resistance	R_Z	I_Z Specified value				Ω
Reverse current	I_R	V_R Specified value				μA

Note) 1. Test method according to the JIS C7031 testing

2. Rated input/output frequency: 5 MHz

3. *1: The V_Z value is for the temperature of 25°C . In other cases, carry out the temperature compensation.

*2: Guaranteed at 20 ms after power application.

■ Electrical characteristics within part numbers $T_a = 25^\circ\text{C}$

Part Number	Zener voltage				Reverse current		Temperature coefficient of zener voltage		Marking Symbol
	Min (V)	Nom (V)	Max (V)	I_Z (mA)	Max (μA)	V_R (V)	Typ (mV/ $^\circ\text{C}$)	I_Z (mA)	
MAZS024	2.28	2.40	2.60	5	120	1.0	-1.6	5	T
MAZS027	2.50	2.70	2.90	5	120	1.0	-2.0	5	2 or 2_ or 2^
MAZS0270L	2.50	2.60	2.75						2_
MAZS0270H	2.65	2.80	2.90						2^
MAZS030	2.80	3.00	3.20	5	50	1.0	-2.1	5	3 or 3_ or 3^
MAZS0300L	2.80	2.90	3.05						3_
MAZS0300H	2.95	3.10	3.20						3^
MAZS033	3.10	3.30	3.50	5	20	1.0	-2.4	5	F or F_ or F^
MAZS0330L	3.10	3.20	3.35						F_
MAZS0330H	3.25	3.40	3.50						F^
MAZS036	3.40	3.60	3.80	5	10	1.0	-2.4	5	H or H_ or H^
MAZS0360L	3.40	3.50	3.65						H_
MAZS0360H	3.55	3.70	3.80						H^
MAZS039	3.70	3.90	4.10	5	10	1.0	-2.5	5	K or K_ or K^
MAZS0390L	3.70	3.80	3.97						K_
MAZS0390H	3.87	4.00	4.10						K^
MAZS043	4.00	4.30	4.60	5	10	1.0	-2.5	5	L or L_ or L- or L^
MAZS0430L	4.03	4.10	4.26						L_
MAZS0430M	4.17	4.30	4.40						L-
MAZS0430H	4.31	4.40	4.54						L^
MAZS047	4.40	4.70	5.00	5	2.0	1.0	-1.4	5	N or N_ or N- or N^
MAZS0470L	4.45	4.60	4.69						N_
MAZS0470M	4.59	4.70	4.83						N-
MA7Z0470H	4.74	4.90	4.99						N^
MAZS051	4.80	5.10	5.40	5	1.0	2.0	-0.8	5	5 or 5_ or 5- or 5^
MAZS0510L	4.87	5.00	5.12						5_
MAZS0510M	5.00	5.10	5.26						5-
MAZS0510H	5.14	5.30	5.40	5^					
MAZS056	5.30	5.60	6.00	5	0.5	2.5	1.2	5	P or P_ or P- or P^
MAZS0560L	5.30	5.40	5.58						P_
MAZS0560M	5.48	5.60	5.76						P-
MAZS0560H	5.66	5.80	5.95	P^					
MAZS062	5.80	6.20	6.60	5	0.2	4.0	2.3	5	6 or 6_ or 6- or 6^
MAZS0620L	5.85	6.00	6.15						6_
MAZS0620M	6.05	6.20	6.36						6-
MAZS0620H	6.24	6.40	6.56	6^					
MAZS068	6.40	6.80	7.20	5	0.1	4.0	3.0	5	R or R_ or R- or R^
MAZS0680L	6.44	6.60	6.77						R_
MAZS0680M	6.64	6.80	6.98						R-
MAZS0680H	6.85	7.00	7.20	R^					
MAZS075	7.00	7.50	7.90	5	0.1	5.0	4.0	5	7 or 7_ or 7- or 7^
MAZS0750L	7.07	7.30	7.43						7_
MAZS0750M	7.29	7.50	7.67						7-
MAZS0750H	7.51	7.70	7.89						7^
MAZS082	7.70	8.20	8.70	5	0.1	5.0	4.6	5	8 or 8_ or 8- or 8^
MAZS0820L	7.77	7.90	8.17						8_
MAZS0820M	8.03	8.20	8.43						8-
MAZS0820H	8.29	8.50	8.70						8^
MAZS091	8.50	9.10	9.60	5	0.1	6.0	5.5	5	9 or 9_ or 9- or 9^
MAZS0910L	8.58	8.80	9.02						9_
MAZS0910M	8.87	9.10	9.33						9-
MAZS0910H	9.14	9.40	9.60						9^

■ Electrical characteristics within part numbers (continued) $T_a = 25^\circ\text{C}$

Part Number	Zener voltage				Reverse current		Temperature coefficient of zener voltage		Marking Symbol
	V_Z (V)			I_Z (mA)	I_R		S_Z		
	Min (V)	Nom (V)	Max (V)		Max (μA)	V_R (V)	Typ (mV/ $^\circ\text{C}$)	I_Z (mA)	
MAZS100	9.40	10.00	10.60	5	0.05	7.0	6.4	5	10 or 10_ or 10- or 10^
MAZS1000L	9.44	9.70	9.92						10_
MAZS1000M	9.75	10.00	10.25						10-
MAZS1000H	10.07	10.30	10.59						10^
MAZS110	10.40	11.00	11.60	5	0.05	8.0	7.4	5	11 or 11_ or 11- or 11^
MAZS1100L	10.40	10.70	10.94						11_
MAZS1100M	10.73	11.00	11.28						11-
MAZS1100H	11.05	11.30	11.60						11^
MAZS120	11.40	12.00	12.70	5	0.05	9.0	8.4	5	12 or 12_ or 12- or 12^
MAZS1200L	11.40	11.70	11.96						12_
MAZS1200M	11.73	12.00	12.33						12-
MAZS1200H	12.06	12.30	12.68						12^
MAZS130	12.40	13.00	14.10	5	0.05	10.0	9.4	5	13 or 13_ or 13- or 13^
MAZS1300L	12.40	12.70	12.99						13_
MAZS1300M	12.73	13.00	13.40						13-
MAZS1300H	13.25	13.70	14.08						13^
MAZS150	13.90	15.00	15.60	5	0.05	11.0	11.4	5	15 or 15_ or 15- or 15^
MAZS1500L	13.90	14.30	14.76						15_
MAZS1500M	14.60	15.00	15.35						15-
MAZS1500H	14.95	15.30	15.60						15^
MAZS160	15.30	16.00	17.10	5	0.05	12.0	12.4	5	16 or 16_ or 16- or 16^
MAZS1600L	15.30	15.70	16.09						16_
MAZS1600M	15.70	16.00	16.50						16-
MAZS1600H	16.26	16.70	17.10						16^
MAZS180	16.90	18.00	19.10	5	0.05	13.0	14.4	5	18 or 18_ or 18- or 18^
MAZS1800L	16.90	17.30	17.76						18_
MAZS1800M	17.55	18.00	18.45						18-
MAZS1800H	18.20	18.70	19.10						18^
MAZS200	18.80	20.00	21.20	5	0.05	15.0	16.4	5	20 or 20_ or 20- or 20^
MAZS2000L	18.85	19.30	19.81						20_
MAZS2000M	19.50	20.00	20.50						20-
MAZS2000H	20.15	20.70	21.19						20^
MAZS220	20.80	22.00	23.30	5	0.05	17.0	18.4	5	22 or 22_ or 22- or 22^
MAZS2200L	20.80	21.30	21.86						22_
MAZS2200M	21.45	22.00	22.55						22-
MAZS2200H	22.10	22.70	23.24						22^
MAZS240	22.80	24.00	25.60	5	0.05	19.0	20.4	5	24 or 24_ or 24- or 24^
MAZS2400L	22.80	23.30	23.97						24_
MAZS2400M	23.50	24.00	24.70						24-
MAZS2400H	24.35	25.00	25.60						24^
MAZS270	25.10	27.00	28.90	2	0.05	21.0	23.4	2	27 or 27_ or 27- or 27^
MAZS2700L	25.30	26.00	26.70						27_
MAZS2700M	26.30	27.00	27.70						27-
MAZS2700H	27.30	28.00	28.70						27^
MAZS300	28.00	30.00	32.00	2	0.05	23.0	26.6	2	30 or 30_ or 30- or 30^
MAZS3000L	28.30	29.00	29.70						30_
MAZS3000M	29.30	30.00	30.80						30-
MAZS3000H	30.20	31.00	31.80						30^
MAZS330	31.00	33.00	35.00	2	0.05	25.0	29.7	2	33 or 33_ or 33- or 33^
MAZS3300L	31.20	32.00	32.80						33_
MAZS3300M	32.20	33.00	33.80						33-
MAZS3300H	33.20	34.00	34.90						33^

■ Electrical characteristics within part numbers (continued) $T_a = 25^\circ\text{C}$

Part Number	Zener voltage				Reverse current		Temperature coefficient of zener voltage		Marking Symbol
	Min (V)	Nom (V)	Max (V)	I_Z (mA)	Max I_R (μA)	V_R (V)	Typ S_Z (mV/ $^\circ\text{C}$)	I_Z (mA)	
MAZS360	34.00	36.00	38.00	2	0.05	27.0	33.0	2	36 or 36_ or 36- or 36^
MAZS3600L	34.10	35.00	35.90						36_
MAZS3600M	35.10	36.00	36.90						36-
MAZS3600H	36.10	37.00	37.90						36^
MAZS390	37.00	39.00	41.00	2	0.05	30.0	35.6	2	39 or 39_ or 39- or 39^
MAZS3900L	37.10	38.00	39.00						39_
MAZS3900M	38.00	39.00	40.00						39-
MAZS3900H	39.00	40.00	41.00						39^

Request for your special attention and precautions in using the technical information and semiconductors described in this material

- (1) An export permit needs to be obtained from the competent authorities of the Japanese Government if any of the products or technologies described in this material and controlled under the "Foreign Exchange and Foreign Trade Law" is to be exported or taken out of Japan.
- (2) The technical information described in this material is limited to showing representative characteristics and applied circuit examples of the products. It does not constitute the warranting of industrial property, the granting of relative rights, or the granting of any license.
- (3) The products described in this material are intended to be used for standard applications or general electronic equipment (such as office equipment, communications equipment, measuring instruments and household appliances).
Consult our sales staff in advance for information on the following applications:
 - Special applications (such as for airplanes, aerospace, automobiles, traffic control equipment, combustion equipment, life support systems and safety devices) in which exceptional quality and reliability are required, or if the failure or malfunction of the products may directly jeopardize life or harm the human body.
 - Any applications other than the standard applications intended.
- (4) The products and product specifications described in this material are subject to change without notice for reasons of modification and/or improvement. At the final stage of your design, purchasing, or use of the products, therefore, ask for the most up-to-date Product Standards in advance to make sure that the latest specifications satisfy your requirements.
- (5) When designing your equipment, comply with the guaranteed values, in particular those of maximum rating, the range of operating power supply voltage and heat radiation characteristics. Otherwise, we will not be liable for any defect which may arise later in your equipment.
Even when the products are used within the guaranteed values, redundant design is recommended, so that such equipment may not violate relevant laws or regulations because of the function of our products.
- (6) When using products for which dry packing is required, observe the conditions (including shelf life and after-unpacking standby time) agreed upon when specification sheets are individually exchanged.
- (7) No part of this material may be reprinted or reproduced by any means without written permission from our company.

Please read the following notes before using the datasheets

- A. These materials are intended as a reference to assist customers with the selection of Panasonic semiconductor products best suited to their applications.
Due to modification or other reasons, any information contained in this material, such as available product types, technical data, and so on, is subject to change without notice.
Customers are advised to contact our semiconductor sales office and obtain the latest information before starting precise technical research and/or purchasing activities.
- B. Panasonic is endeavoring to continually improve the quality and reliability of these materials but there is always the possibility that further rectifications will be required in the future. Therefore, Panasonic will not assume any liability for any damages arising from any errors etc. that may appear in this material.
- C. These materials are solely intended for a customer's individual use.
Therefore, without the prior written approval of Panasonic, any other use such as reproducing, selling, or distributing this material to a third party, via the Internet or in any other way, is prohibited.