

# Agilent HSMA/C/L-C120, HSMD/G/S/H-C120, HSMM/N/Q/R-C120 Right Angle ChipLED Data Sheet



## Features

- Small size right angle mount
- 0603 industry standard footprint
- Operating temperature range of  $-30^{\circ}\text{C}$  to  $+85^{\circ}\text{C}$
- Available in various colors
- Compatible with IR solder reflow
- Available in 8 mm tape on 7" diameter reel
- Reel sealed in zip locked moisture barrier bags

## Description

This series of right angle mount ChipLEDs is designed with the smallest footprint to achieve high density of components on board. They have the industry standard footprint of 1.6 mm x 1.0 mm and a height of only 0.6 mm. This makes them very suitable for cellular phone and mobile equipment backlighting and

indication application where space is a constraint. They are available in a wide range of color combination. In order to facilitate automated pick and place operation, these ChipLEDs are shipped in tape and reel, with 4000 units per reel. These parts are compatible with IR soldering.

## Applications

- LCD backlighting
- Keypad backlighting
- Pushbutton backlighting
- Symbol indicator

**CAUTION:** HSMM/N/Q/R-C120 LEDs are Class 1 ESD sensitive per MIL-STD-1686. Please observe appropriate precautions during handling and processing. Refer to Agilent Technologies Application Note AN-1142 for additional details.



## Package Dimensions

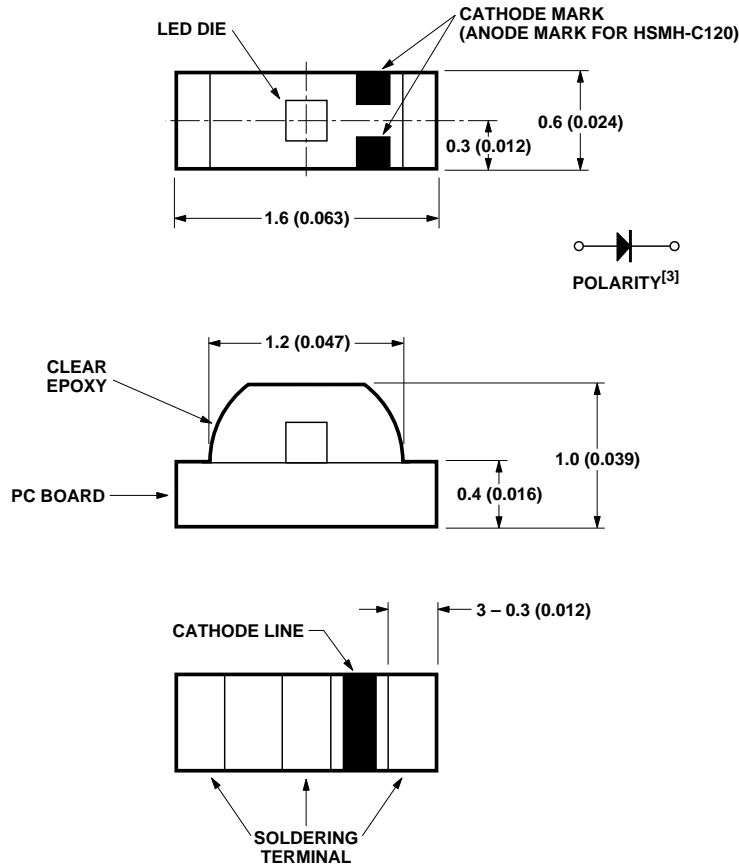

- NOTES:
1. ALL DIMENSIONS IN MILLIMETERS (INCHES).
  2. TOLERANCE IS  $\pm 0.1$  mm ( $\pm 0.004$  IN.) UNLESS OTHERWISE SPECIFIED.
  3. POLARITY FOR HSMH-C120 WILL BE THE OPPOSITE OF WHAT IS SHOWN ON ABOVE DRAWING.

## Device Selection Guide

AS AlInGaP			InGaN		Package Description
Amber	Red	Orange	Green	Blue	
H SMA-C120	H SMC-C120	H SML-C120	H SMM-C120 H SMQ-C120	H SMN-C120 H SMR-C120	Untinted, Non Diffused

AlGaAs		GaP		Package Description
Red	Green	Orange	HER	
H SMH-C120	H SMG-C120	H SMD-C120	H SMS-C120	Untinted, Non Diffused

**Absolute Maximum Ratings at T<sub>A</sub> = 25°C**

Parameter	HSMA/C/L-C120	HSMD/G/S-C120	HSMH-C120	HSMM/N-C120	HSMQ/R-C120	Units
DC Forward Current <sup>[1] [2]</sup>	25	20	25	20	20	mA
Power Dissipation	60	52	65	78	78	mW
Reverse Voltage (I <sub>R</sub> = 100 μA)	5	5	5	5	5	V
LED Junction Temperature	95	95	95	95	95	°C
Operating Temperature Range	-30 to +85					°C
Storage Temperature Range	-40 to +85					°C
Soldering Temperature	See IR soldering profile (Figure 6)					

**Notes:**

- Derate linearly as shown in Figure 4.
- Drive currents above 5 mA are recommended for best long term performance.

**Electrical Characteristics at T<sub>A</sub> = 25°C**

Part Number	Forward Voltage V <sub>F</sub> (Volts) @ I <sub>F</sub> = 20 mA		Reverse Breakdown V <sub>R</sub> (Volts) @ I <sub>R</sub> = 100 μA	Capacitance C (pF), V <sub>F</sub> = 0, f = 1 MHz	Thermal Resistance R <sub>θJ-PIN</sub> (°C/W)
	Typ.	Max.	Min.	Typ.	Typ.
HSMA-C120	1.9	2.4	5	11	400
HSMC-C120	1.9	2.4	5	15	400
HSML-C120	1.9	2.4	5	20	400
HSMD-C120	2.2	2.6	5	7	350
HSMG-C120	2.2	2.6	5	9	350
HSMS-C120	2.1	2.6	5	5	350
HSMH-C120	1.8	2.6	5	20	400
HSMM-C120	3.4	3.9	5	45	450
HSMN-C120	3.4	3.9	5	45	450
HSMQ-C120	3.4	3.9	5	100	450
HSMR-C120	3.4	3.9	5	100	450

**Note:**

- V<sub>F</sub> tolerance: ±0.1 V



### Color Bin Limits

#### Orange Color Bins

Bin ID	Dom. Wavelength (nm)	
	Min.	Max.
A	597.0	600.0
B	600.0	603.0
C	603.0	606.0
D	606.0	609.0
E	609.0	612.0
F	612.0	615.0

Tolerance:  $\pm 1$  nm

#### Notes:

1. Bin categories are established for classification of products. Products may not be available in all categories.

Please contact your Agilent representative for information on currently available bins.

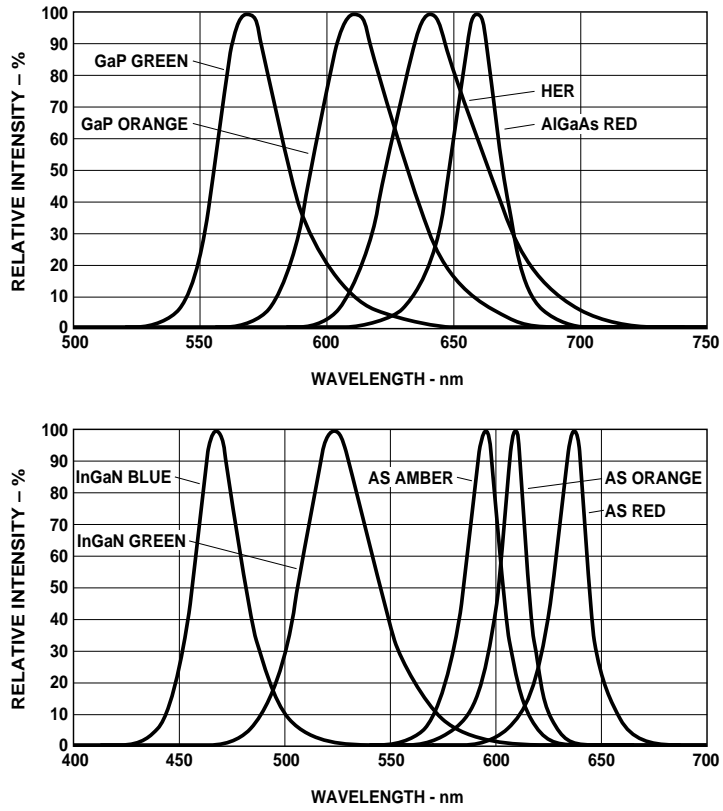

Figure 1. Relative intensity vs. wavelength.

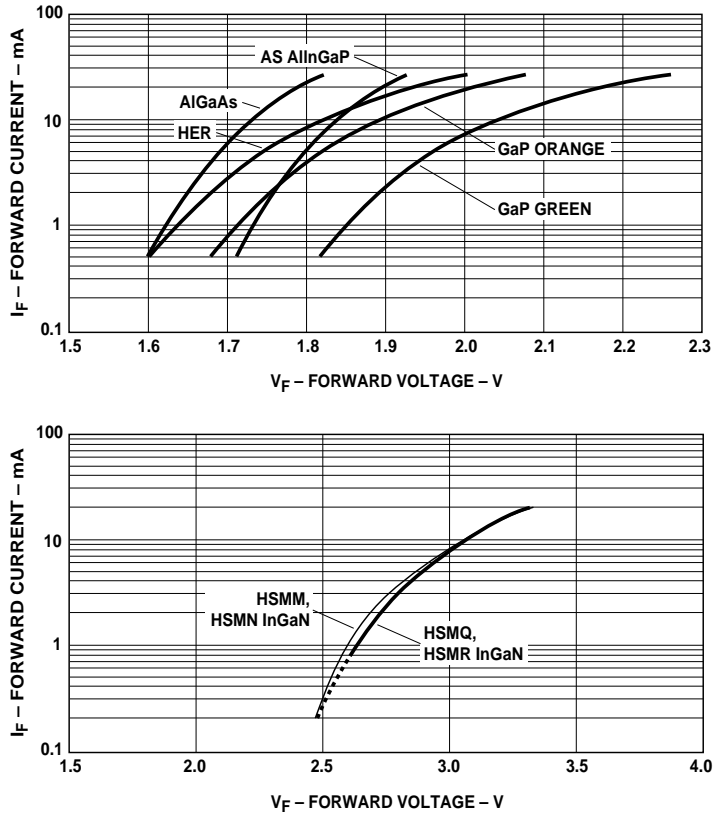

Figure 2. Forward current vs. forward voltage.

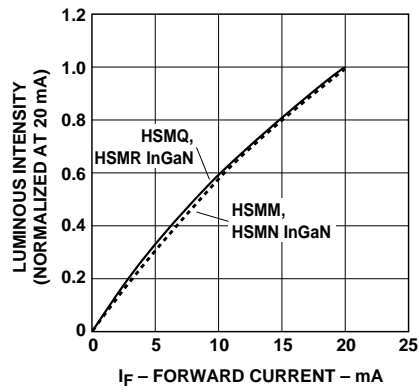
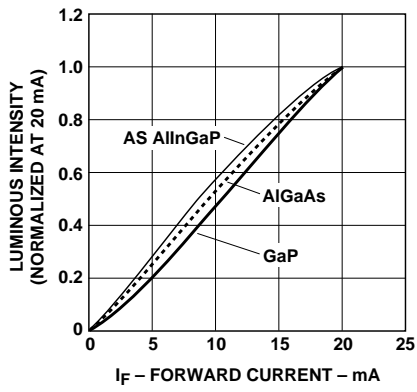

Figure 3. Luminous intensity vs. forward current.

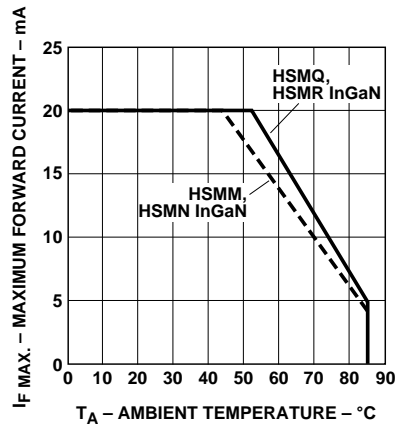
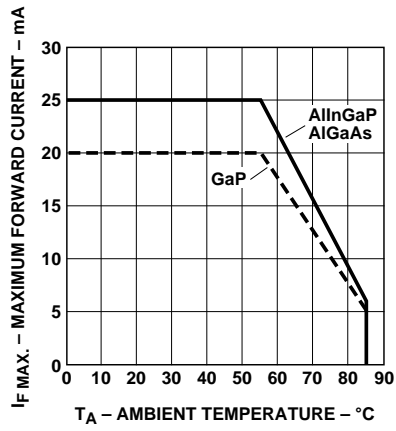

Figure 4. Maximum forward current vs. ambient temperature.

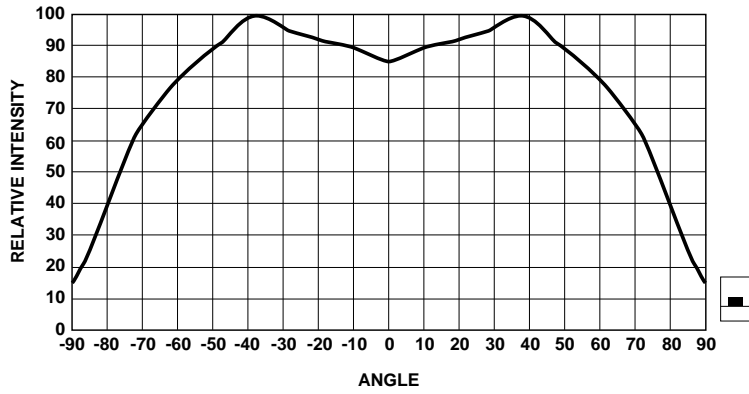
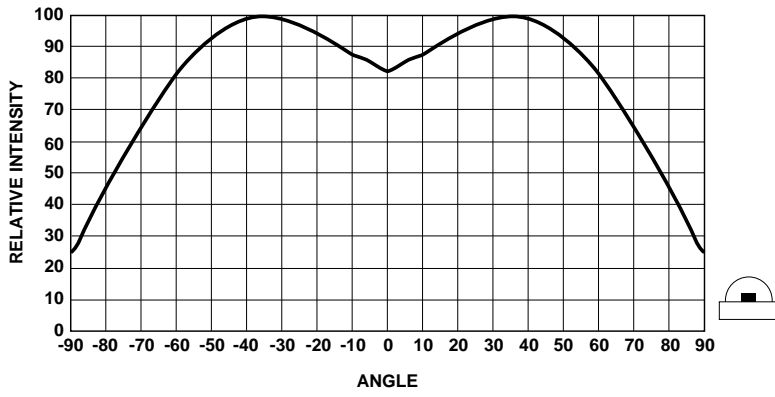

Figure 5. Relative intensity vs. angle.

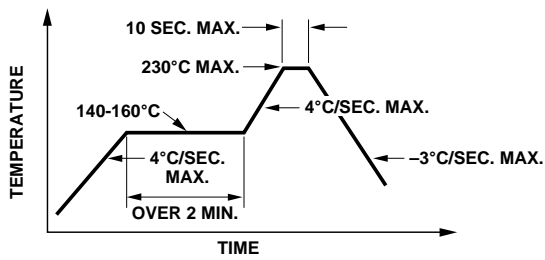

Figure 6. Recommended reflow soldering profile.

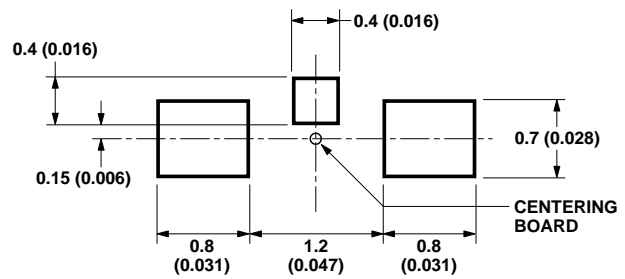

Figure 7. Recommended soldering pattern.

Note: All dimensions in millimeters (inches).

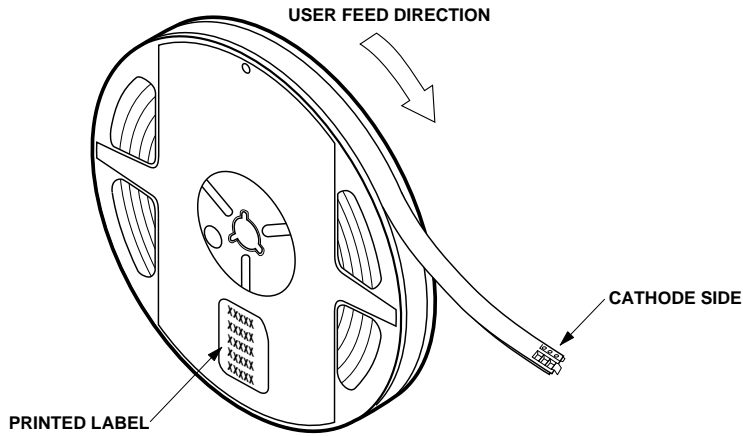
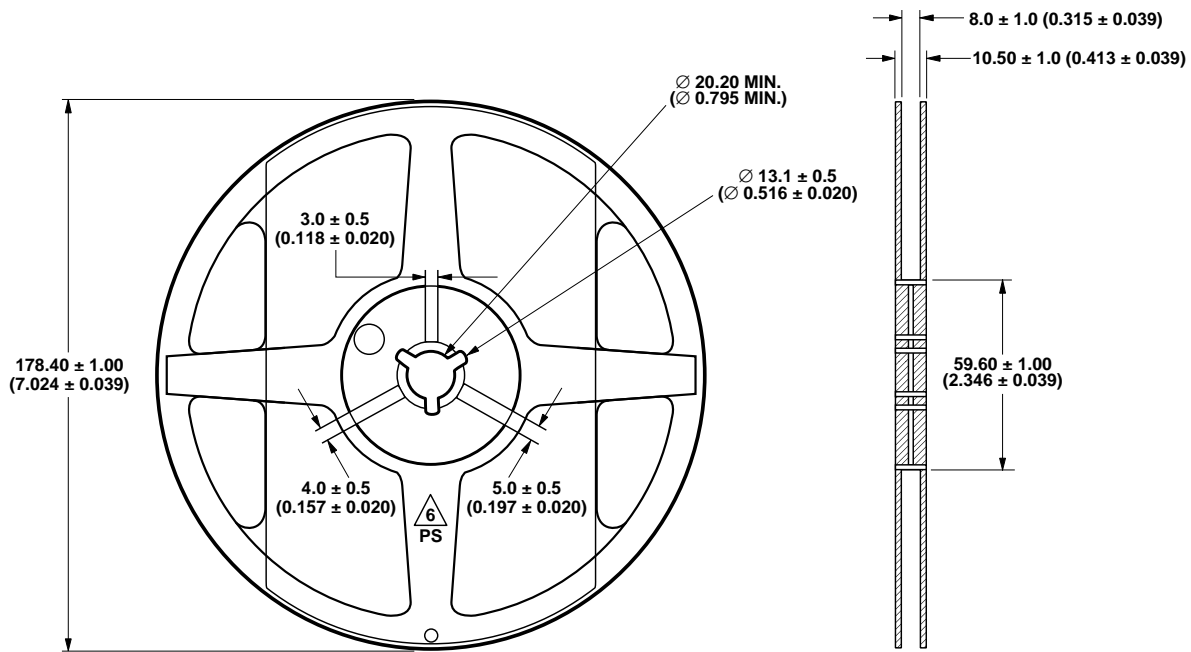

Figure 8. Reeling orientation.



NOTE: ALL DIMENSIONS IN MILLIMETERS (INCHES).

Figure 9. Reel dimensions.



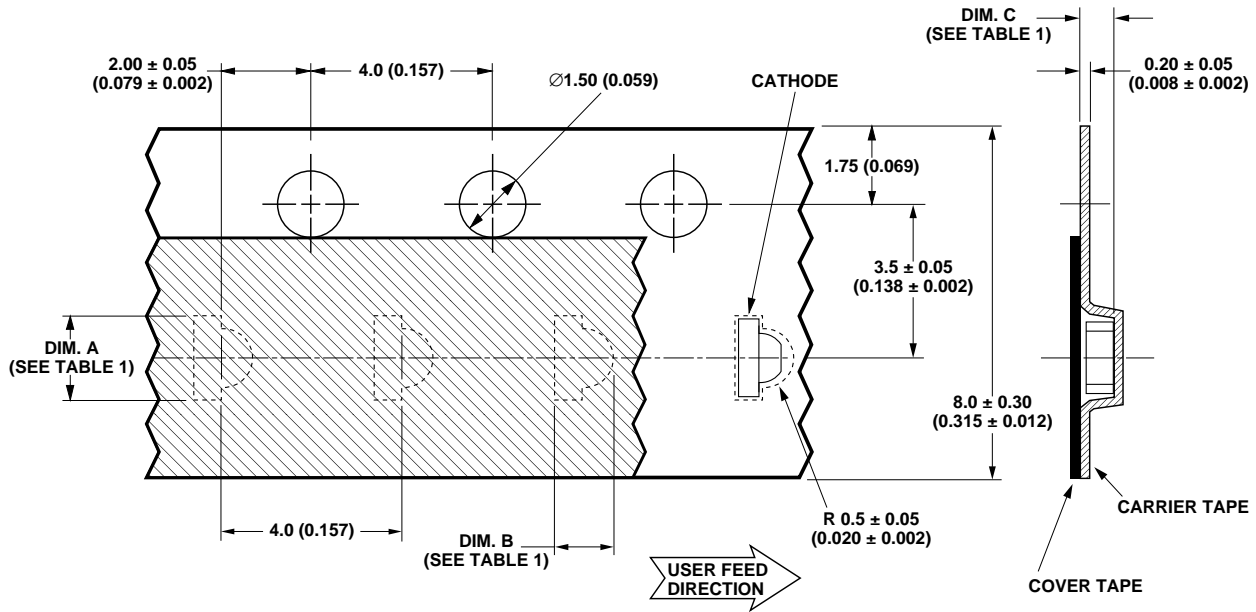

TABLE 1  
DIMENSIONS IN MILLIMETERS (INCHES)

PART NUMBER	DIM. A ± 0.10 (0.004)	DIM. B ± 0.10 (0.004)	DIM. C ± 0.10 (0.004)
HSMx-C120 SERIES	1.90 (0.075)	1.15 (0.045)	0.75 (0.030)

Figure 10. Tape dimensions.

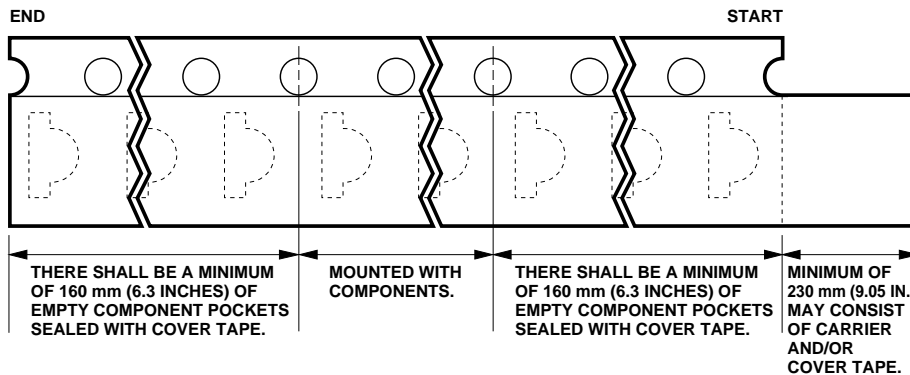

Figure 11. Tape leader.

**Notes:**

1. All dimensions in millimeters (inches).
2. Tolerance is  $\pm 0.1$  mm ( $\pm 0.004$  in.) unless otherwise specified.

**Convective IR Reflow Soldering**

For more information on IR reflow soldering, refer to Application Note 1060, *Surface Mounting SMT LED Indicator Components*.

Storage Condition: 5 to 30°C @ 60% RH max.

Baking is required under the condition:

- a) the blue silica gel indicator becoming white/transparent color
- b) the pack has been opened for more than 1 week

Baking recommended condition:

60 +/- 5°C for 20 hours.

**[www.agilent.com/semiconductors](http://www.agilent.com/semiconductors)**

For product information and a complete list of distributors, please go to our web site.

For technical assistance call:

Americas/Canada: +1 (800) 235-0312 or  
(408) 654-8675

Europe: +49 (0) 6441 92460

China: 10800 650 0017

Hong Kong: (+65) 6271 2451

India, Australia, New Zealand: (+65) 6271 2394

Japan: (+81 3) 3335-8152(Domestic/International), or 0120-61-1280(Domestic Only)

Korea: (+65) 6271 2194

Malaysia, Singapore: (+65) 6271 2054

Taiwan: (+65) 6271 2654

Data subject to change.

Copyright © 2002 Agilent Technologies, Inc.

April 6, 2002  
5988-5401EN



**Agilent Technologies**