

W6691

ISDN S/T Interface Transceiver

Data Sheet

The information described in this document is the exclusive intellectual property of Winbond Electronics Corp and shall not be reproduced without permission from Winbond.

Winbond is providing this document only for reference purposes for W6691-based system design. Winbond assumes no responsibility for errors or omissions. All data and specifications are subject to change without notice.



Table of Contents-

1.	GENERAL DESCRIPTION	8
2.	FEATURES	8
3.	PIN CONFIGURATIONS	9
4.	PIN DESCRIPTION.....	11
5.	SYSTEM DIAGRAM AND APPLICATIONS.....	14
6.	BLOCK DIAGRAM	16
7.	FUNCTIONAL DESCRIPTIONS	17
7.1	Main Block Functions.....	17
7.1.1	Internal Block Function Description	17
7.1.2	Interface and Operating Modes	18
7.2	Layer 1 Function Description	18
7.2.1	S/T Interface Transmitter/Receiver.....	18
7.2.2	Receiver Clock Recovery And Timing Generation.....	23
7.2.3	Layer 1 Activation/Deactivation	23
7.2.4	Layer 1 Activation /Deactivation in LT-S Mode	29
7.2.5	D Channel Access Control.....	32
7.2.6	Frame Alignment	33
7.2.7	Multiframe Synchronization	34
7.2.8	Test Functions	36
7.3	B Channel Switching.....	37
7.4	PCM Port	38
7.5	Channel HDLC Controller	38
7.5.1	D Channel Message Transfer Modes	39
7.5.2	Reception of Frames in D Channel.....	40
7.5.3	Transmission of Frames in D Channel	41
7.6	GCI Mode Serial Interface Bus	41
7.6.1	GCI Mode C/I Channel Handling	44
7.6.2	GCI Mode Monitor Channel Handling	44
7.7	8-bit Microprocessor Interface	45
8.	REGISTER DESCRIPTIONS	46
8.1	D Channel HDLC Controller Register Address Map	46
8.2	GCI Bus Control Register Address Map.....	47
8.3	Miscellaneous Register Address Map	48
8.4	D Channel HDLC Controller Register Memory Map.....	49
8.5	GCI Bus Register Memory Map.....	50
8.6	Miscellaneous Register Memory Map	51



8.7	D Channel HDLC Controller Register Description.....	51
8.7.1	D_ch receive FIFO D_RFIFO Read Address 00H	51
8.7.2	D_ch transmit FIFO D_XFIFO Write Address 01H.....	51
8.7.3	D_ch command register D_CMDR Write Address 02H	51
8.7.4	D_ch Mode Register D_MODE Read/Write Address 03H.....	53
8.7.5	Interrupt Status Register ISTA Read_clear Address 04H.....	54
8.7.6	Interrupt Mask Register IMASK Read/Write Address 05H.....	55
8.7.7	D_ch Extended Interrupt Register D_EXIR Read_clear Address 06H	55
8.7.8	D_ch Extended Interrupt Mask Register D_EXIM Read/Write Address 07H	56
8.7.9	D_ch Transmitter Status Register D_XSTA Read Address 0AH.....	56
8.7.10	D_ch Receive Status Register D_RSTA Read Address 0BH.....	56
8.7.11	D_ch SAPI Address Mask D_SAM Read/Write Address 0EH.....	57
8.7.12	D_ch SAPI1 Register D_SAP1 Read/Write Address 0FH.....	58
8.7.13	D_ch SAPI2 Register D_SAP2 Read/Write Address 10H.....	58
8.7.14	D_ch TEI Address Mask D_TAM Read/Write Address 11H	58
8.7.15	D_ch TEI1 Register D_TEI1 Read/Write Address 12H.....	58
8.7.16	D_ch TEI2 Register D_TEI2 Read/Write Address 13H.....	59
8.7.17	D_ch Receive Frame Byte Count High D_RBCH Read Address 16H.....	59
8.7.18	D_ch Receive Frame Byte Count Low D_RBCL Read Address 17H.....	59
8.8	GCI Bus Register Description.....	60
8.8.1	Channel Selection Register CSEL Read/Write Address 18H.....	60
8.8.2	Command/Indication Receive Register CIR Read Address 1AH	60
8.8.3	Command/Indication Transmit Register CIX Read/Write Address 1BH	60
8.8.4	S/Q Channel Receive Register SQR Read Address 1CH	61
8.8.5	S/Q Channel Transmit Register SQX Read/Write Address 1DH.....	61
8.8.6	Monitor Receive Channel 0 MO0R Read Address 20H	61
8.8.7	Monitor Transmit Channel 0 MO0X Read/Write Address 21H.....	62
8.8.8	Monitor Channel 0 Interrupt Register MO0I Read_clear Address 22H	62
8.8.9	Monitor Channel 0 Control Register MO0C Read/Write Address 23H.....	62
8.8.10	GCI Mode Control/Status Register GCR Read Address 26H	63
8.8.11	Monitor Receive Channel 1 Register MO1R Read Address 27H	63
8.8.12	Monitor Transmit Channel 1 Register MO1X Read/Write Address 28H	64
8.8.13	Monitor Channel 1 Interrupt Register MO1I Read_clear Address 29H	64
8.8.14	Monitor Channel 1 Control Register MO1C Read/Write Address 2AH.....	64
8.8.15	GCI CI1 Indication Register CI1R Read Address 31H	65
8.8.16	GCI CI1 Command Register CI1X Read/Write Address 32H	65
8.8.17	GCI Extended Interrupt Register GCI_EXIR Read_clear Address 34H	65
8.8.18	GCI Extended Interrupt Mask Register GCI_EXIM Read/Write Address 35H.....	66

8.9	Miscellaneous Register.....	66
8.9.1	Timer 1 Register TIMR1 Read/Write Address 38H	66
8.9.2	Timer 2 TIMR2 Read/ Write Address 39H	67
8.9.3	Peripheral Control Register PCR Read/Write Address 3AH	67
8.9.4	Peripheral I/O Data Register PIODR Read/Write Address 3BH	68
8.9.5	SFCTL Switch Functional Control Register Read/Write Address 3CH	69
8.9.6	ACTL1 Auxiliary Control Register 1 Read/Write Address 3DH.....	70
8.9.7	ACTL2 Auxiliary Control Register2 Read/Write Address 3EH.....	70
8.9.8	ACTL3 Auxiliary Control Register 3 Read/Write Address 3FH	71
8.10	B1 Channel HDLC Controller Register Address MAP.....	71
8.11	B1 Channel HDLC Controller Register Memory Map.....	72
8.11.1	B1_ch receive FIFO B1_RFIFO Read Address 50H.....	72
8.11.2	B1_ch transmit FIFO B1_XFIFO Write Address 51H.....	72
8.11.3	B1_ch command register B1_CMDR Read/Write Address 53H	73
8.11.4	B1_ch Mode Register B1_MODE Read/Write Address 54H	74
8.11.5	B1_ch Extended Interrupt Register B1_EXIR Read_clear Address 56H	75
8.11.6	B1_ch Extended Interrupt Mask Register B1_EXIM Read/Write Address 57H.....	76
8.11.7	B1_ch Status Register B1_STAR Read Address 58H	76
8.11.8	B1_ch Address Mask Register 1 B1_ADM1 Read/Write Address 59H	77
8.11.9	B1_ch Address Mask Register 2 B1_ADM2 Read/Write Address 5AH	77
8.11.10	B1_ch Address Register 1 B1_ADR1 Read/Write Address 5BH.....	78
8.11.11	B1_ch Address Register 2 B1_ADR2 Read/Write Address 5CH.....	78
8.11.12	B1_ch Receive Frame Byte Count Low B1_RBCL Read Address 5DH.....	78
8.11.13	B1_ch Receive Frame Byte Count High B1_RBCH Read Address 5EH.....	78
8.11.14	B1_ch Transmit Idle Pattern B1_IDLE Read/Write Address 5FH	79
8.12	B2 Channel HDLC Controller Register Address Map	80
8.13	B2 Channel HDLC Controller Register Memory Map.....	81
9.	ELECTRICAL CHARACTERISTICS.....	82
9.1	Absolute Maximum Rating.....	82
9.2	Power Supply.....	82
9.3	DC Characteristics.....	82
9.4	Preliminary Switching Characteristics	84
9.4.1	PCM Interface Timing.....	84
9.4.2	Detailed PCM Tming	85
9.4.3	8-bit Microprocessor Timing	86
9.5	AC Timing Test Conditions.....	89
10.	ORDERING INFORMATION	89
11.	PACKAGE DIMENSIONS.....	90



List of Figures-

Fig.3.1 W6691 Pin Configuration - Intel Bus Mode	9
Fig.3.2 W6691 Pin Configuration – Motorola Bus Mode	10
Fig.5.1 ISDN Internet Passive S-card with Two POTS Connections	14
Fig.5.2 ISDN PAXB Application.....	15
Fig.6.1 W6691 Functional Block Diagram.....	16
Fig.7.1 Frame Structure at S/T Interface.....	19
Fig.7.2 W6691 Wiring Configuration in TE Applications	20
Fig.7.3 External Transmitter Circuitry.....	21
Fig.7.4 External Receiver Circuitry.....	22
Fig.7.5 Layer 1 Activation/Deaction State Diagram – TE/LT-T Normal Mode	27
Fig.7.6 Layer 1 Activation/Deactivation State Diagram – TE/LT-T SPECIAL Mode	28
Fig.7.7 Layer 1 Activation/Deactivation State Diagram in LT-S	31
Fig.7.9 SSP and SCP Test Signals	37
Fig.7.10 GCI TE Mode Channel Structure	42
Fig.7.11 GCI Non –Terminal Mode Channel Structure	43



List of Tables-

TABLE 7.1 OUTPUT PHASE DELAY COMPENSATION TABLE	23
TABLE 7.2 LAYER 1 COMMAND CODES	25
TABLE 7.3 LAYER 1 INDICATION CODES	26
TABLE 7.4 LAYER 1 COMMAND CODES	29
TABLE 7.5 LAYER 1 INDICATION CODES	30
TABLE 7.8 D PRIORITY CLASSES.....	32
TABLE 7.9 D PRIORITY COMMANDS/INDICATIONS	32
TABLE 7.10 MULTIFRAME STRUCTURE IN S/T INTERFACE	35
TABLE 8.1 D CHANNEL HDLC CONTROLLER REGISTER ADDRESS MAP.....	46
TABLE 8.2 GCI BUS CONTROL REGISTER ADDRESS MAP.....	47
TABLE 8.3 MISCELLANEOUS REGISTER ADDRESS MAP	48
TABLE 8.4 D CHANNEL HDLC CONTROLLER REGISTER MEMORY MAP	49
TABLE 8.5 GCI BUS REGISTER MEMORY MAP.....	50
TABLE 8.6 MISCELLANEOUS REGISTER MEMORY MAP.....	51
TABLE 8.7 B1 CHANNEL HDLC CONTROLLER REGISTER ADDRESS MAP.....	71
TABLE 8.8 B1 CHANNEL HDLC CONTROLLER REGISTER MEMORY MAP	72
TABLE 8.9 B2 CHANNEL HDLC CONTROLLER REGISTER ADDRESS MAP	80
TABLE 8.10 B2 CHANNEL HDLC CONTROLLER REGISTER MEMORY MAP	81

REVISION HISTORY

VERSION	DATE	DESCRIPTION
1.0	Jan 2001	The first version is edited.
1.1	Sep 2001	W6691 Pin Configuration -- Intel Bus mode is modified on page 11. W6691 Pin Configuration – Motorola Bus Mode is modified on page 12 Pin Description is modified on page 13. The chapter 7.1.2 Interface and Operating Mode description is changed on page 20. The transformer ratio 1:1 is changed to 2:1 on Fig 7.3 and 7.4 page 23 and page 24.
1.2	Mar 2003	V_{DD} and V_{DDA} (output) described are error description on page 15. It is corrected as $V_{DD} = 3.3V \pm 5\%$. V_{DDA} is 5.0V output signal for chip internal use. It should be connected with 2.2uF capacitor for supplying stable voltage. Add CNC and CPC pin description on page 15. The CNC pin and CPC pin should be connected with 2.2uF for supplying stable voltage. The Operating Supply Voltage $V_{DD} = 5V \pm 5\%$ in the Capacitances description is error on page 97. It is corrected as $3.3V \pm 5\%$.
1.3	Mar 2003	The $V_{DD} = 5V \pm 5\%$ in chapter 9.2 power supply section should be corrected as $3.3V \pm 5\%$. The $V_{DD} = 5V \pm 5\%$ in chapter 9.3 DC characteristic section should be corrected as $3.3V \pm 5\%$. The $V_{DD} = 5V \pm 5\%$ in chapter 9.5 AC Timing Test Conditions should be corrected as $3.3V \pm 5\%$.
1.4	May 2003	The V_{DDA} (output) described is error description on page 15. It is 5.0V $\pm 5\%$ output for monitoring. (Notice the 5.0V is generated from W6691 internal power pump) Analog power supply current: activated section $V_{DD} = 5.0V$ condition described on page 100 is error. It is corrected as $V_{DD} = 3.3V$
1.5	June 11, 2003	The XTAL2 is pin 41 described on table of page 16. It is a mistake. It is corrected as pin 39. The pin 20 described on page 14 is V_{DD} . It is mistake. It is corrected as WR#. Pin 37 CLK is not described in data sheet. The description is added on page 15. MBIT shown page 13 and 14 is omitted. W6691 doesn't provide the MBIT function.



1. GENERAL DESCRIPTION

W6691 consists of one D channel HDLC controller and two B HDLC controller channel access. The HDLC controller facilitates efficient access to signaling, data and voice services. It provides multiplex/non-multiplexed 8-bit microprocessor interface. The interface is selected by external MBS selection. In addition, W6691 can be operated in TE, LT-S and LT-T mode programmed by external pin. In TE mode, W6691 provides PCM bus or GCI bus to connect with CODEC. In LT mode, it can be used in NT2 application. W6691 also provides various B channel switching function among PCM, GCI and Layer2. It adopts 3.3V process to manufacture. The FIFO size of D channel is 64 bytes. The FIFO size of two B channels are 128 bytes. Two extended external interrupts are designed for peripheral interrupt saving extra interrupt circuit design. One layer activation indication output can be programmed by microprocessor control or W6691 chip internal control. The DPLL circuit is designed in chip to generate the DCL and FSC signal for NT2 application. It can eliminate extra DPLL circuit on board. In order to save a lot of crystal on board, W6691 can provide 7.68MHz OSC signal for other chips that need the clock in TE or NT2 application.

2. FEATURES

- Full Duplex 2B+D S/T interface transceiver compliant with ITU I.430 Recommendation
- One D channel HDLC controller
 - Maskable address recognition
 - Transparent (HDLC) mode
 - FIFO buffer (2 * 64)
- Two B channel HDLC controller
 - Maskable address recognition
 - Transparent (HDLC) mode
 - FIFO buffer (2 * 128)
- Various B channel switching capabilities and PCM intercom
- Two PCM CODEC interfaces for speech and POTS application
- GCI interface connects with other peripheral device in TE, LT-S and LT-T mode.
- Multi-frame synchronization
- 8-bits Intel mode or Motorola mode interface accesses B channel and Command/Indication channel.
- The timing clock recovery depends on operating mode.
- DPLL circuit designed in chip for NT2 application.
- Four kinds of the extended interrupt trigger mode.
- Two kinds of output interrupt polarity selection can be programmed. (Positive level and negative level)
- Added reset signal to reset other chip.
- Loop back function for testing.
- Layer1 Activate Indication Output can be connected to LED



- Two of programmable timer
- 3.3 Volt power supply
- 3.3 Volt output; Maximum Input is 5.0Volt
- Advanced CMOS technology
- Packaged in 64 pin LQFP

3. PIN CONFIGURATIONS

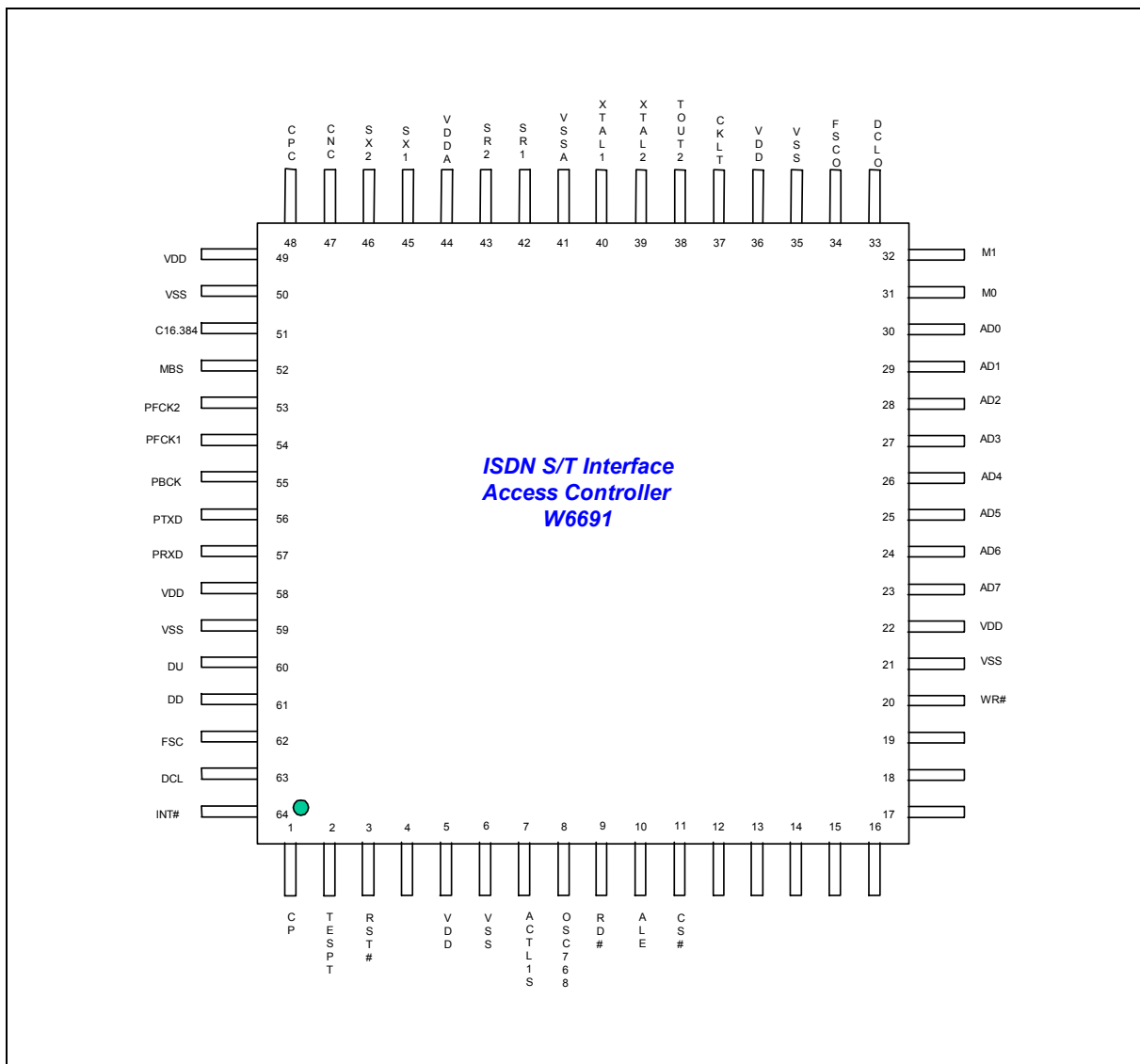

Fig.3.1 W6691 Pin Configuration - Intel Bus Mode

Pin Configurations, continued

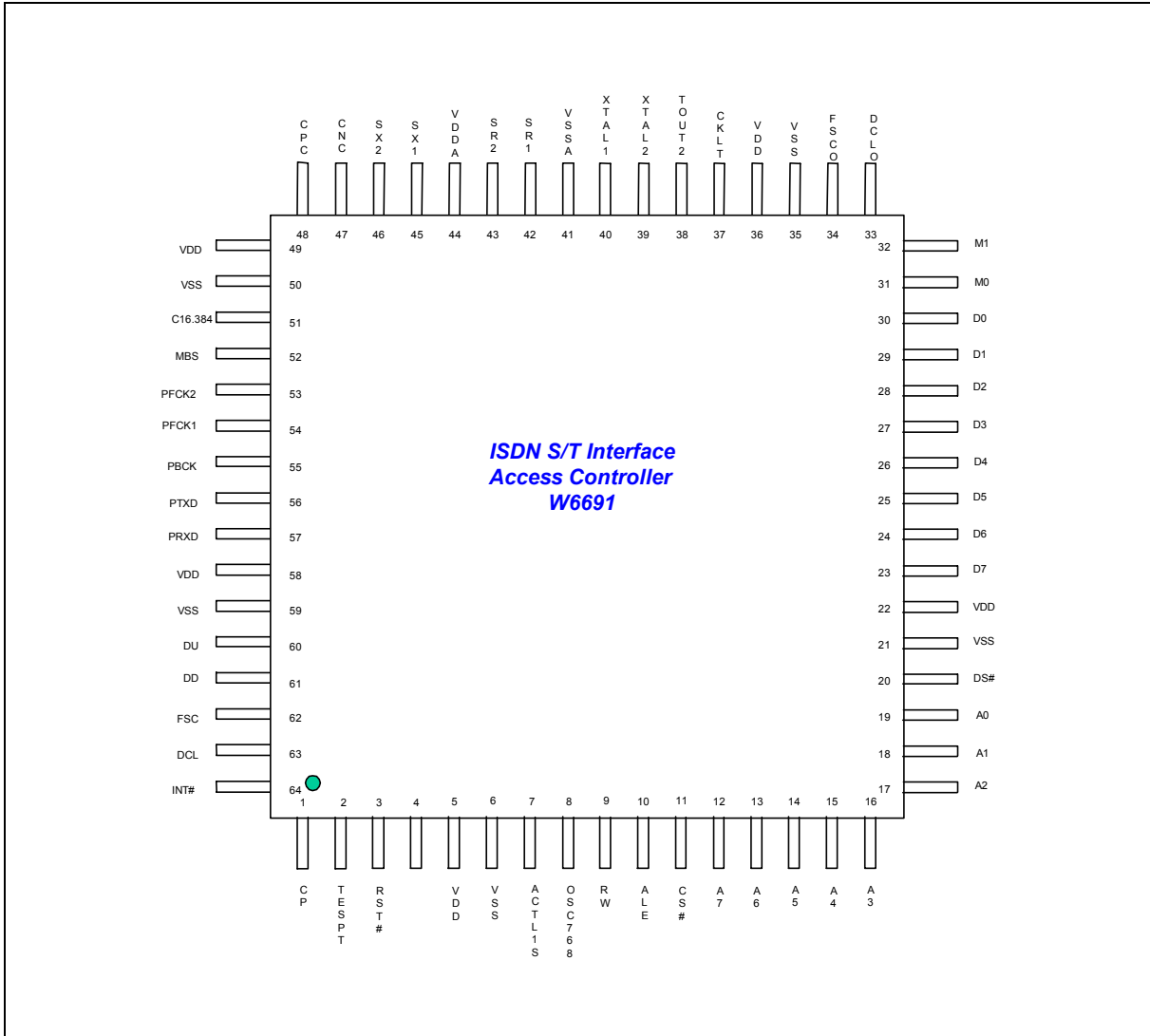

Fig.3.2 W6691 Pin Configuration – Motorola Bus Mode



4. PIN DESCRIPTION

Table 4.1 W6691 pin descriptions

Note: The suffix "#" indicates an active LOW signal. In Intel or Motorola bus mode, all unspecified pins must be left unconnected.

PIN NAME	PIN NO.	TYPE	FUNCTIONS
Intel Bus Mode (Enabled when MBS = HIGH)			
MBS	52	I	Microprocessor bus selector (MBS). This pin must be pulled to HIGH.
AD7-0	23, 24, 25, 26, 27, 28, 29, 30	I/O	Multiplexed address and data bus. During the address phase, AD7-0 contains 8-bit physical address. During the data phase, AD7-AD0 contains data.
CS#	11	I	Chip select.
ALE	10	I	Address Latch Enable. Used to latch addresses.
RD#	9	I	Read.
WR#	20	I	Write.
RST#	3	I	Reset.
INT#	64	O	Interrupt. The interrupt trigger level can be programmable by ACTL2:INTOL. It provides two types of interrupt trigger level including low level and high level.
Motorola Bus Mode (Enabled when MBS = LOW)			
MBS	52	I	Microprocessor bus selector (MBS). This pin must be pulled to LOW.
D7-D0	23, 24, 25, 26, 27, 28, 29, 30	I/O	Data bus.
A7-A0	12, 13, 14, 15, 16, 17, 18, 19	I	Address bus.
CS#	11	I	Chip select.
DS#	20	I	Data strobe.
RW	9	I	Read/Write identify. HIGH is for read and LOW is for write.
RST#	3	I	Reset.
INT#	64	O	Interrupt. The interrupt trigger level can be programmable by ACTL2:INTOL. It provides two types of interrupt trigger level including low level and high level.
GCI Bus			
DCL	63	I/O	GCI Bus Data Clock: the frequency is twice data rate TE mode: 1.536 MHz. LT-T/LT-S mode: 4.096 MHz. NT mode: 512 KHz It needs external pull-up.

PIN NAME	PIN NO.	TYPE	FUNCTIONS
FSC	62	I/O	GCI Bus Frame Synchronization Clock: 8 KHz. It needs external pull-up.
DD	61	I/O	GCI Bus Data Downstream. It needs external pull-up.
DU	60	I/O	GCI Bus Data Upstream. It needs external pull-up.
CP/BCL	1	O	CP – output 512 KHz in LT-T mode. BCL – output 768 KHz in TE mode.
FSCO	34	O	Output FSCO clock 8 KHz for LT-T/LT-S mode (NT2 application). It is synchronous to DCLO.
DCLO	33	O	Output DPLL clock 4.096 MHz for LT-T/LT-S mode (NT2 application). It is synchronous to T interface clock.
C16.384	51	I	16.384 MHz clock input for internal DPLL circuit to generate FSCO and DCLO.
CKLT	37	I	In the LT-T mode operation, if the application adopts W6691 internal DPLL function to generate 8 KHz Frame Synchronization Clock from FSCO and 4.096 MHz Data Clock from DCLO for NT2 system clock, the CKLT 8KHz clock derived from one of other LT-T CP clock or itself CP clock (by Multiplexer). On the other hand, if the application doesn't adopt W6691 internal DPLL function, It should be tied to ground (V_{SS}).
PCM Interface (It is only used in TE Mode)			
PFCK1	54	O	PCM port1 frame synchronization signal, with 8 KHz repetition rate and 8 bits pulse width.
PFCK2	53	O	PCM port2 frame synchronization signal, with 8 KHz repetition rate and 8 bits pulse width.
PBCK	55	O	PCM bit synchronization clock of 1.536 MHz.
PTXD	56	O	PCM transmit bus data output. A maximum of two channels with 64 Kbits/s data rate can be multiplexed on this signal. It needs external pull-up.
PRXD	57	I	PCM bus receive data input. A maximum of two channels with 64 Kbits/s data rate can be multiplexed on this signal. It needs external pull-up.
ISDN Signals and External Crystal			
SR1	42	I	S/T bus receiver input (negative).
SR2	43	I	S/T bus receiver input (positive).
SX1	45	O	S/T bus transmitter output (positive).

PIN NAME	PIN NO.	TYPE	FUNCTIONS
SX2	46	O	S/T bus transmitter output (negative).
XTAL1	40	I	Crystal or Oscillator clock input. The clock frequency: 7.68MHz \pm 100PPM.
XTAL2	39	O	Crystal clock output. Left unconnected when using oscillator.
Functional Test			
TESTP	2	I	Used to enable normal operation (1) or enter test mode (0). In normal operation, it should be tied to high.
Timer2 Expiration Output			
TOUT2	38	O	Timer 2 output. A square wave with 50 % duty cycle, 1~63 mS period can be generated.
Clock Pulse			
OSC768	8	O	It provides output 7.68MHz clock. It does not synchronize to S interface.
Operating Mode			
M0	31	I	Setting of operating mode
M1	32	I	Setting of operating mode
Peripheral Input Port and Output Port			
ACTL1S	7	O	<p>Activate Layer1 Status. This pin can be pulled to low level or programmed by microprocessor by ACTL2: ACTL1S when Layer1 operates in activate.</p> <p>ACTL2: ACTL1S:</p> <p>0: When Layer 1 operates in activate state, ACTL1S pin is pulled to low level. In contrast, if Layer 1 operates in deactivate state, ACTL1S pin is driven to high level.</p> <p>1: The ACTL1 output level is programmed by microprocessor (ACTL2: ACTL1S).</p>
Power and Ground			
CNC	47		It should be connected with CPC pin 48 by 2.2uF capacitor for stabiling internal power voltage.
CPC	48		It should be connected with CNC pin 47 by 2.2uF capacitor for stabiling internal power voltage.
V _{DD}	5, 22, 36, 49, 58	I	Digital Power Supply (3.3V \pm 5%).
V _{DDA}	44	O	Analog Power Supply (5.0V \pm 5%). It should be connected with 2.2uF capacitor for stabiling internal power voltage.
V _{SS}	6, 21, 35, 50, 59	I	Digital Ground.
V _{SSA}	41	I	Analog Ground.

5. SYSTEM DIAGRAM AND APPLICATIONS

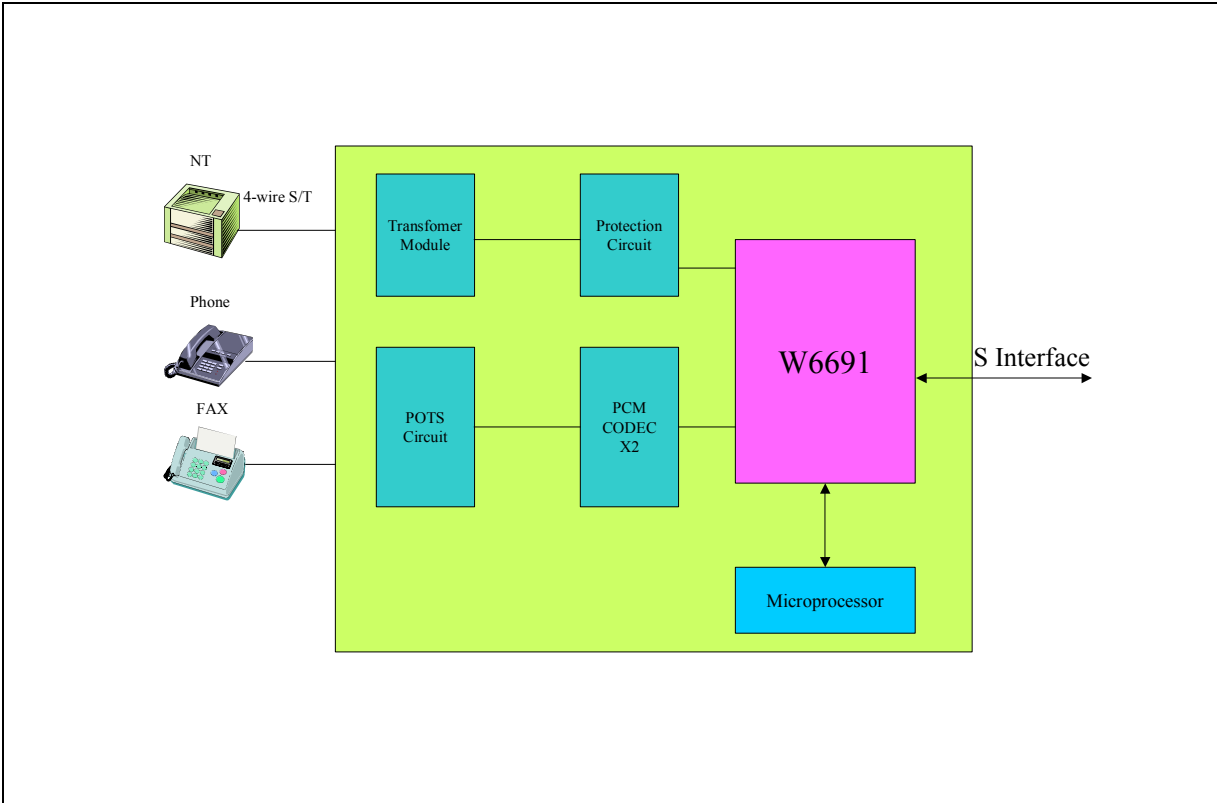

Fig.5.1 ISDN Internet Passive S-card with Two POTS Connections

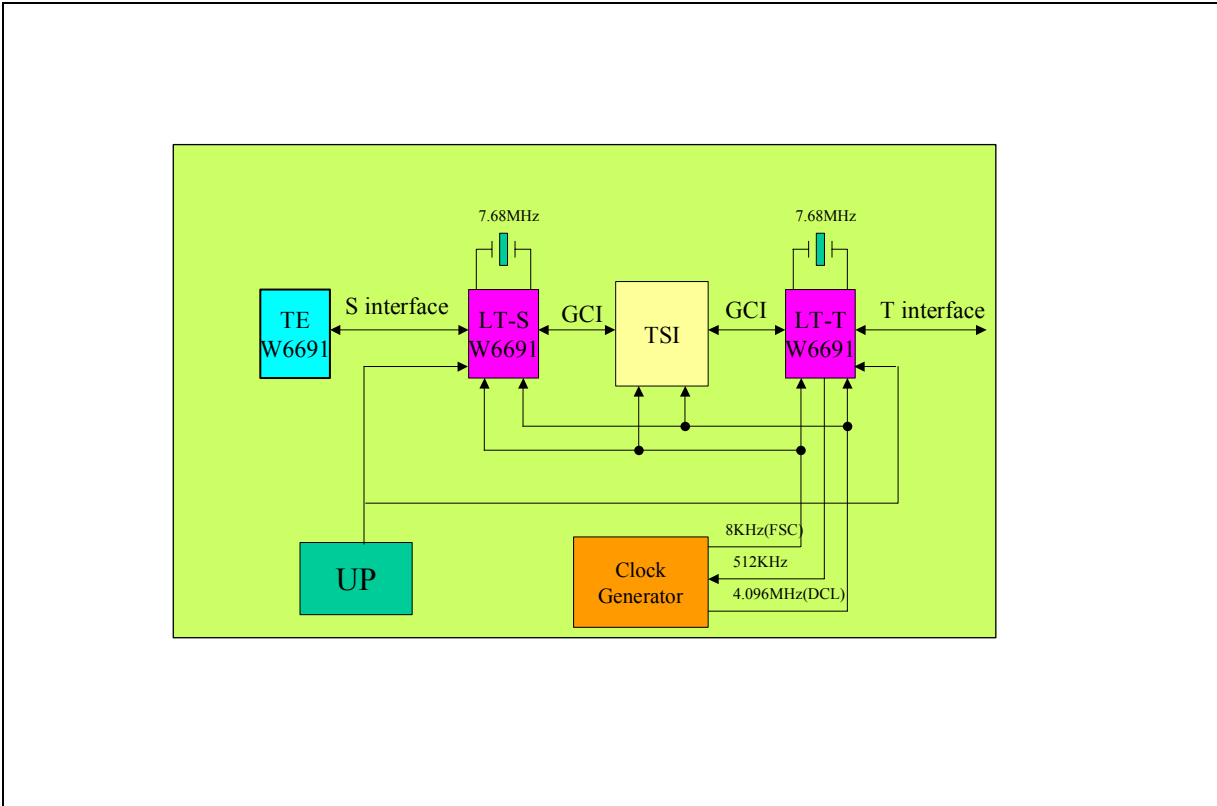

Fig.5.2 ISDN PAXB Application

6. BLOCK DIAGRAM

The block diagram of W6691 is shown in Figure 6.1

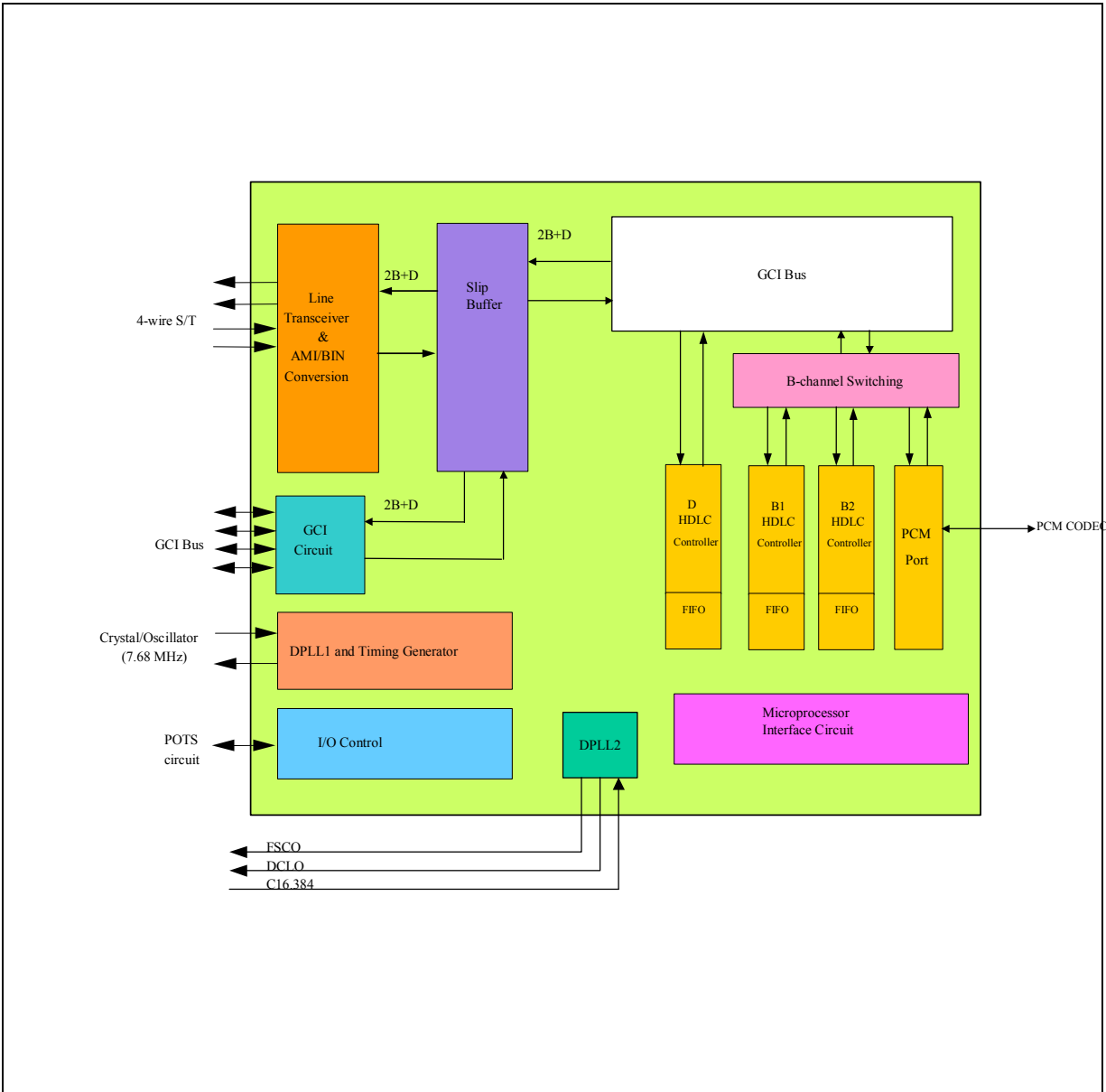

Fig.6.1 W6691 Functional Block Diagram



7. FUNCTIONAL DESCRIPTIONS

7.1 Main Block Functions

7.1.1 Internal Block Function Description

The functional block diagram of W6691 is shown in Fig.6.1. The main function blocks are:

- Layer 1 function according to ITU-T I.430
- B channel switching
- GCI bus interface
- PCM port (x 2) and internal B channel switching
- D channel HDLC controller
- DPLL 2 circuit generating 4.096 MHz clock for NT2 application

The layer 1 function includes:

- S/T bus transmitter/receiver
- Timing recovery using Digital Phase Locked Loop (DPLL) circuit
- Layer 1 activation/deactivation
- D channel access control
- Frame alignment
- Multi-frame synchronization
- Test functions

The serial interface bus performs the multiplexing/demultiplexing of D and 2B channels.

The B channel switching determines the connection between layer 1/GCI, layer 2 and PCM.

GCI bus is for TE, LT-S and LT-T mode applications.

The PCM port provides two 64 kbps clear channels to connect to PCM codec chips.

The D channel HDLC controller performs the LAPD (Link Access Procedure on the D channel) protocol according to ITU-T I.441/Q.921 recommendation.

The peripheral simple I/O is used to control other peripheral devices such as CODEC, SLIC, DTMF detector, LEDs.



7.1.2 Interface and Operating Modes

The W6691 can be configured for the following application:

- ISDN terminals --- TE mode (M1 = 0 & M0 = 0)
 - ISDN subscriber line termination --- LT-S mode (M1=1 & M0 = 0)
 - ISDN trunk line termination ---LT-T mode (M1 = 0 & M0 = 1)
- TE, LT-S and LT-T modes are configured by setting mode pins (M1 and M0).

7.2 Layer 1 Function Description

7.2.1 S/T Interface Transmitter/Receiver

According to ITU-T I.430, pseudo-ternary code with 100% pulse width is used in both directions of transmission on the S/T interface. The binary "1" is represented by no line signal (zero volt), whereas a binary "0" is represented by a positive or negative pulse.

Data transmissions on the S/T interface are arranged as frame structures. The frame is 250 μ s long and consists of 48 bits, which corresponds to a 192 kbit/s line rate. Each frame carries two octets of B1 channel, two octets of B2 channel and four D channel bits. Therefore, the 2B+D data rate is 144 kbit/s. The frame structure is shown in Fig.7.1.

The frame begin is marked by a framing bit, which is followed by a DC balancing bit. The first binary "0" following the framing bit balancing bit is of the same polarity as the framing bit balancing bit, and subsequent binary zeros must alternate in polarity.

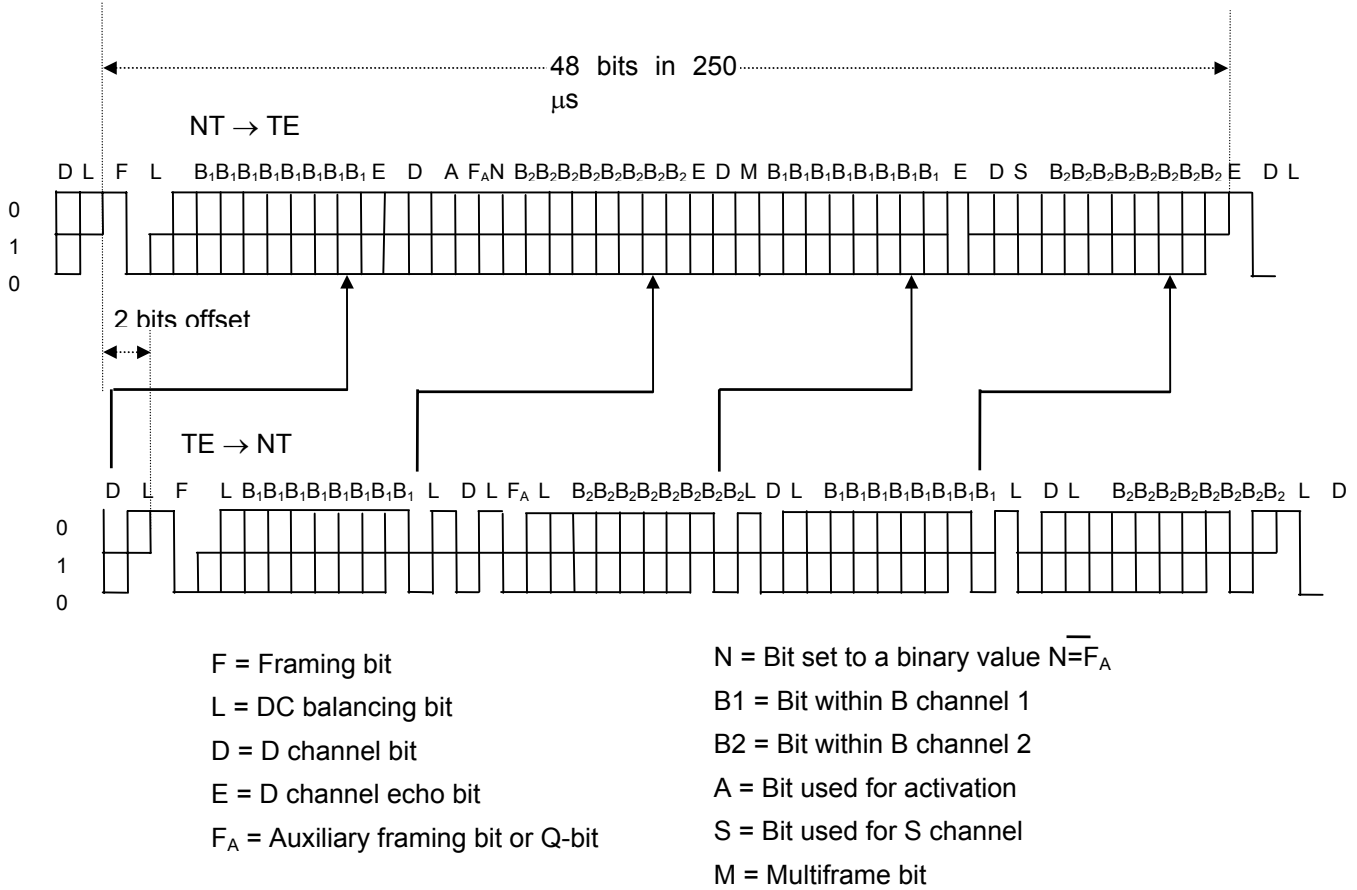
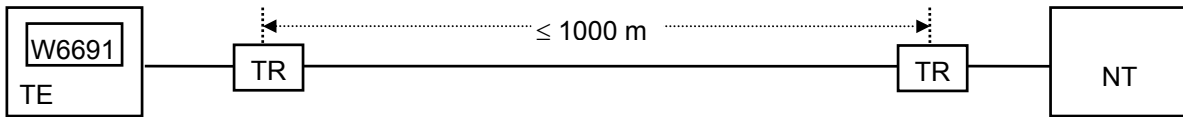
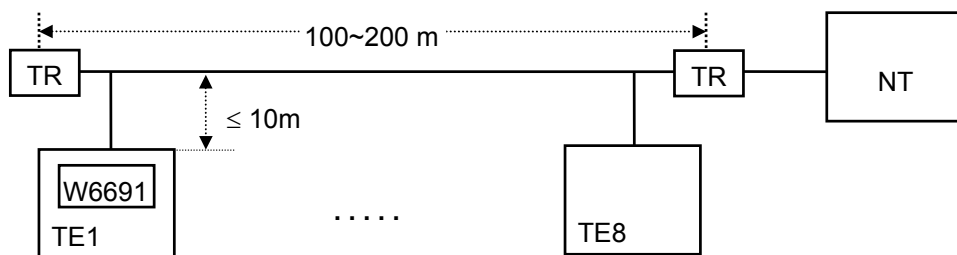

Fig.7.1 Frame Structure at S/T Interface

There are three wiring configurations according to I.430: point-to-point, short passive bus and extended passive bus. They are shown in Fig.7.2.



(a) Point-to-point configuration



(b) Short passive bus configuration

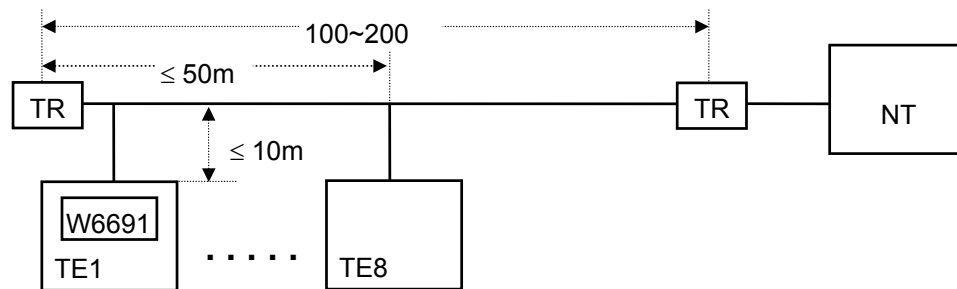

(c) Extended passive bus configuration

TR : Terminating Resistor

Fig.7.2 W6691 Wiring Configuration in TE Applications

The transmitter and receiver are implemented by differential circuits to increase signal to noise ratio (SNR). The nominal differential line pulse amplitude at 100 Ω termination is 750 mV, zero to peak. Transformers with 2:1 turn ration are needed at transmitter and receiver for voltage level translation and DC isolation.

To meet the electrical characteristic requirements in I.430, some additional circuits are needed. At the transmitter side, the external resistors (5 to 10 Ω) are used to adjust the output pulse amplitude and to meet the transmitter active impedance ($\geq 20 \Omega$) when transmitting binary zeros. At the receiver side, the 1.8 kΩ resistors protect the device inputs, while the 10 kΩ resistors (1.8 kΩ + 8.2 kΩ) limit the peak current in impedance tests. The diode bridge is used for overvoltage protection.

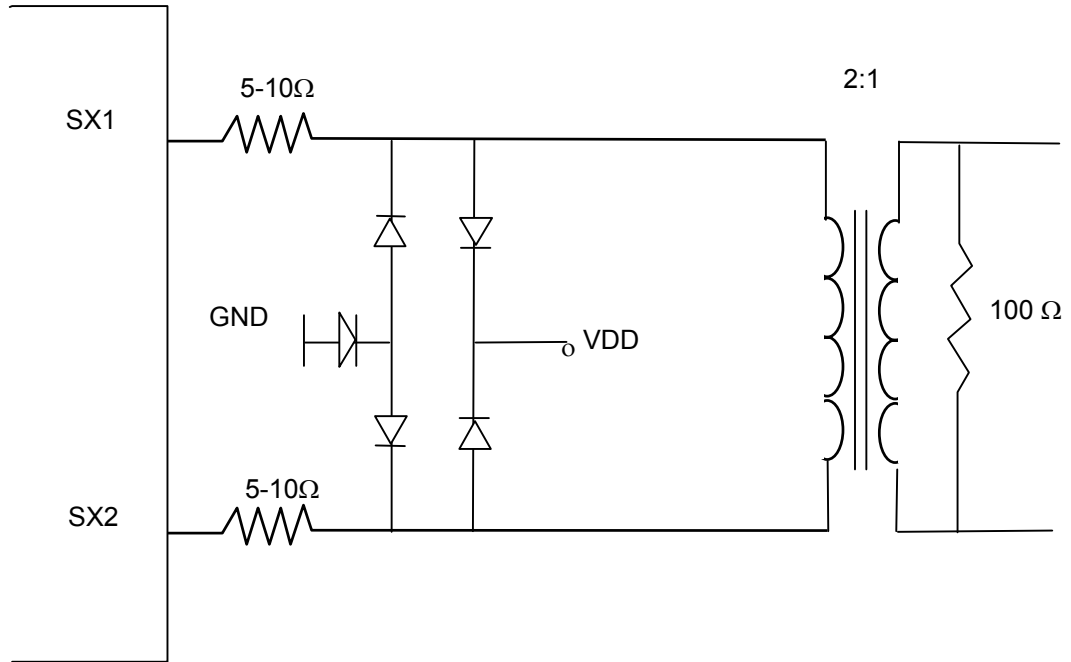

Fig.7.3 External Transmitter Circuitry

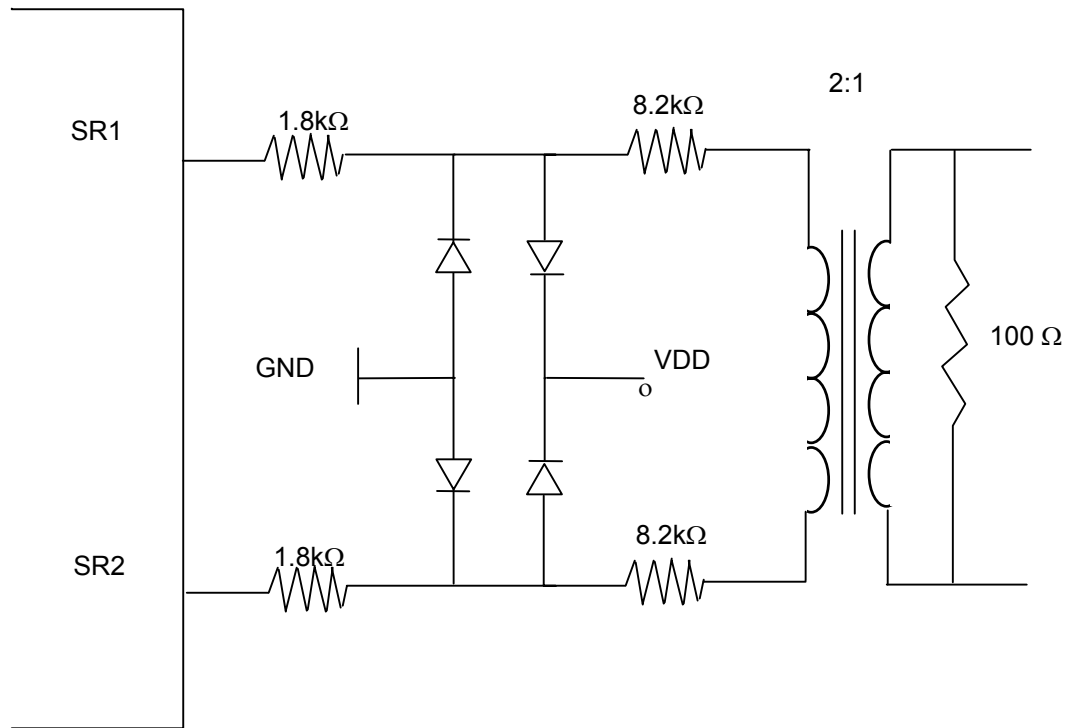

Fig.7.4 External Receiver Circuitry

After hardware reset, the receiver may enter power down state in order to save power consumption. In this state, the internal clocks are turned off, but the analog level detector is still active to detect signal coming from the S interface. The power down state is left either by non-INFO 0 signal from S interface or C/I command from microprocessor.



7.2.2 Receiver Clock Recovery And Timing Generation

1) TE mode

A Digital Phase Locked Loop (DPLL) circuit is used to derive the receiving clock from the received data stream in TE mode application. This DPLL uses a 7.68 MHz clock as reference. According to I.430, the transmit clock is normally delayed by 2 bit time from the receive clock. The "total phase deviation from input to output" is -7% to +15% of a bit period. In some cases, delay compensation may be needed to meet this requirement (see OPS1-0 bits in D_CTL register).

2) LT-T mode

In LT-T mode application, A Digital Phase Locked Loop (DPLL) circuit is also used to derive the receiving clock(192 KHz) from the received data stream.W6691 generates a CP (Clock Pulse) derived from the 192 KHz receiving clock with DPLL. CP clock rate is 512 KHz or 1536 KHz. If CP clock is used to synchronize NT2 clock, W6691 provide a slip buffer to avoid slipping between DCL and CP.

3) LT-S mode

In LT-S modes, A Digital Phase Locked Loop (DPLL) circuit is used to derive the receiving clock from the received data stream. This DPLL uses a 7.68 MHz clock as reference.

TABLE 7.1 OUTPUT PHASE DELAY COMPENSATION TABLE

OPS1	OPS0	EFFECT
0	0	No phase delay compensation
0	1	Phase delay compensation 260 nS
1	0	Phase delay compensation 520 nS
1	1	Phase delay compensation 1040 nS

W6691 does not need RC filter on receiver side, therefore zero delay compensation is selected normally. This is also the default setting.

The PCM output clocks (PFCK1-2, PBCK) are locked to the S-interface timing with jitter. See the electrical specification.

7.2.3 Layer 1 Activation/Deactivation

The layer 1 activation/deactivation procedures are implemented by a finite state machine according to TE/LT-T/LT-S mode. The state transitions are triggered by signals received at S interface or commands issued from microprocessor. The state outputs signals to S interface and indication to microprocessor. The CIX register is used by microprocessor to issue command, and the CIR register is used by microprocessor to receive indication.

Some commands are used for special purposes. They are "layer 1 reset", "analog loopback", "send continuous zeros" and "send single zero".



7.2.3.1 States Descriptions And Command/Indication Codes in TE/LT-T

F3 Deactivated without clock

This is the "deactivated" state of ITU-T I.430. The receive line awake unit is active except during a hardware reset pulse. After reset, once the indication "1111" has been read out, internal clocks will turn off and stay at this state if INFO 0 is received on the S line. The turn off time is approximate 93 ms. The ECK command must be issued to activate the clocks.

F3 Deactivated with clock

This state is identical to "F3 Deactivated without clock" except the internal clocks are enabled. The state is entered by the ECK command. The clocks are enabled approximately 0.5 mS to 4 mS after the ECK command, depending on the crystal capacitances. (It is about 0.5 ms for 12 pF to 33 pF capacitance).

F3 Awaiting Deactivation

The W6691 enters this state after receiving INFO 0 (in states F5 to F8) for 16ms (64 frames). This time constant prevents spurious effect on S interface. Any non-INFO 0 signal on the S interface causes transition to "F5 Identifying Input" state. If this transition does not occur in a specific time (500 - 1000 ms), the microprocessor may issue DRC or ECK command to deactivate layer 1.

F4 Awaiting Signal

This state is reached when an activate request command has been received. In this state, the layer 1 transmits INFO1 and INFO 0 is received from the S interface. The software starts timer T3 of I.430 when issuing activate request command. The software deactivates layer 1 if no signal other than INFO 0 has been received on S interface before expiration of T3.

F5 Identifying Input

After the receipt of any non-INFO 0 signal from NT, the W6691 ceases to transmit INFO 1 and awaits identification of INFO 2 or INFO 4. This state is reached at most 50 μ S after a signal different from INFO 0 is present at the receiver of the S interface.

F6 Synchronized

When W6691 receives an activation signal (INFO 2), it responds with INFO 3 and waits for normal frames (INFO 4). This state is reached at most 6 ms after an INFO 2 arrives at the S interface (in case the clocks were disabled in "F3 Deactivated without clock").

F7 Activated

This is the normal active state with the layer 1 protocol activated in both directions. From state "F6 Synchronized", state F7 is reached at most 0.5 ms after reception of INFO 4. From state "F3 Deactivated without clock" with the clocks disabled, state F7 is reached at most 6 ms after the W6691 is directly activated by INFO 4.

F8 Lost Framing

This is the state where the W6691 has lost frame synchronization and is awaiting resynchronization by INFO 2 or INFO 4 or deactivation by INFO 0.



Special States:

Analog Loop Initiated

On Enable Analog Loop command, INFO 3 is sent by the line transmitter internally to the line receiver (INFO 0 is sent to the line). The receiver is not yet synchronized.

Analog Loop Activated

The receiver is synchronized on INFO 3 which is looped back internally from the transmitter. The indication "TI" or "ATI" is sent depending on whether or not a signal different from INFO 0 is detected on the S interface.

Send Continuous Pulses

A 96 kHz continuous pulse with alternating polarities is sent.

Send Single Pulses

A 2 KHz , isolated pulse with alternating polarities is sent.

Layer 1 Reset

A layer 1 reset command forces the transmission of INFO 0 and disables the S line awake detector. Thus activation from NT is not possible. There is no indication in reset state. The reset state can be left only with ECK command.

TABLE 7.2 LAYER 1 COMMAND CODES

COMMAND	SYM.	CODE	DESCRIPTION
Enable clock	ECK	0000	Enable internal clocks
Layer 1 reset	RST	0001	Layer 1 reset
Send continuous pulses	SCP	0100	Send continuous pulses at 96 KHz
Send single pulses	SSP	0010	Send isolated pulses at 2 KHz
Activate request at priority 8	AR8	1000	Activate layer 1 and set D channel priority level to 8
Activate request at priority 10	AR10	1001	Activate layer 1 and set D channel priority to 10
Enable analog loopback	EAL	1010	Enable analog loopback
Deactivate layer 1	DRC	1111	Deactivate layer 1 and disable internal clocks

**TABLE 7.3 LAYER 1 INDICATION CODES**

INDICATION	SYM.	CODE	DESCRIPTIONS
Clock Enabled	CE	0111	Internal clocks are enabled
Deactivate request downstream	DRD	0000	Deactivation request by S interface, i.e INFO 0 received
Level detected	LD	0100	Signal received, receiver not synchronous
Activate request downstream	ARD	1000	INFO 2 received
Test indication	TI	1010	Analog loopback activated or continuous zeros or single zeros transmitted
Awake test indication	ATI	1011	Level detected during test function
Activate indication with priority class 1	AI8	1100	INFO 4 received, D channel priority is 8 or 9
Activate indication with priority class 2	AI10	1101	INFO 4 received, D channel priority is 10 or 11
Clock disabled	CD	1111	Layer 1 deactivated, internal clocks are disabled

7.2.3.2 State Transition Diagrams in TE/LT-T

The followings are the state transition diagrams, which implement the activation/deactivation state matrix in I.430 (TABLE 5/I.430). The "command" and "s receive" entries in each state octagon keep the state, the "indication" and "s transmit" entries in each state octagon are the state outputs. For example, at "F3 Deactivated with clock" state, the layer 1 will stay at this state if the command is "ECK" and the INFO 0 is received on S interface. At this state, it provides "CE" indication to the microprocessor and transmits INFO 0 on S interface. The "AR8/10" command causes transition to F4 and non-INFO 0 signal causes transition to F5. Note that the command code written by the microprocessor in CIX register and indication code written by layer 1 in CIR register are transmitted repeatedly until a new code is written.

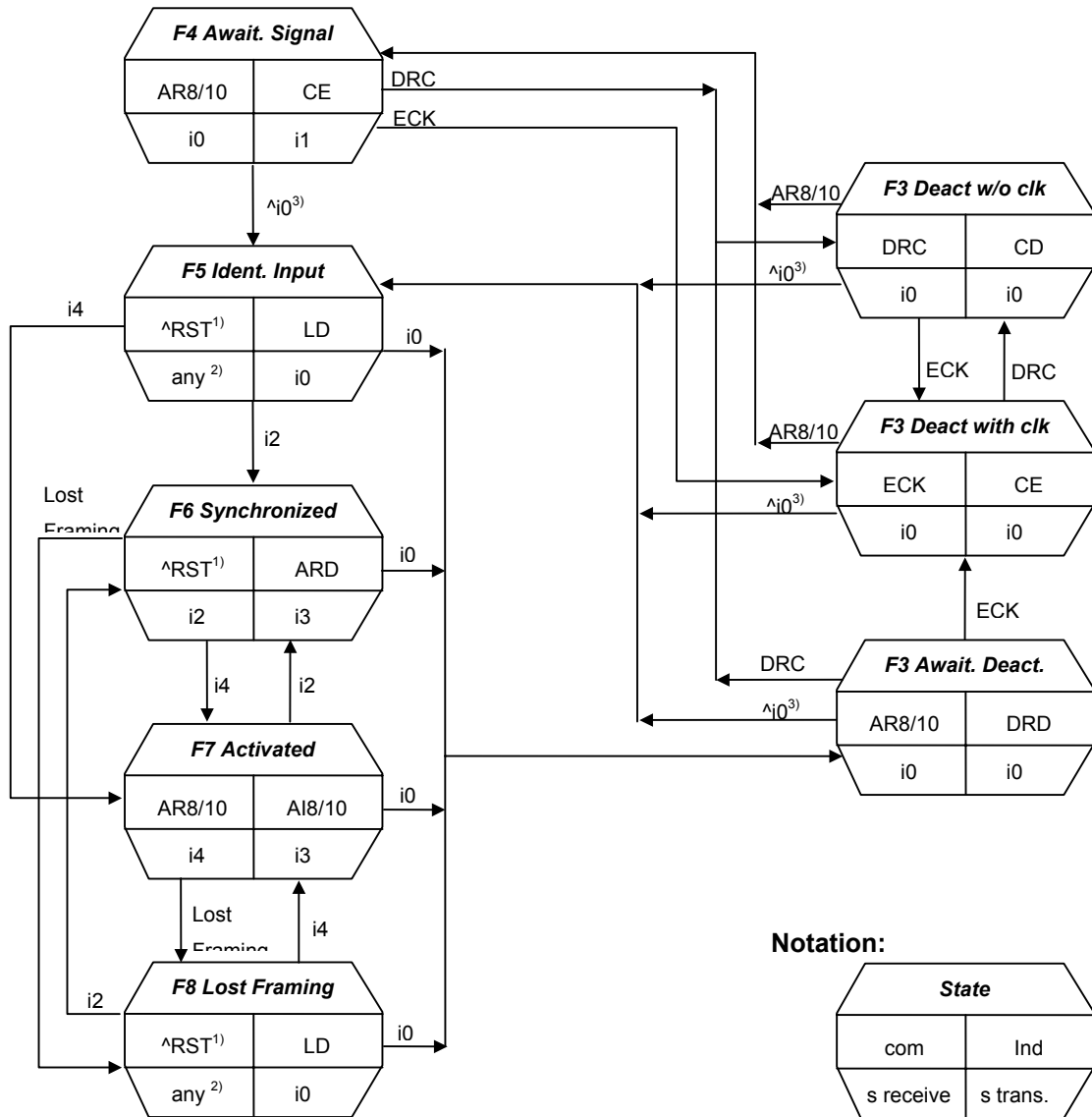

Notes:

1. "ARST" means "NOT layer 1 reset command".
2. "Any" means any signal other than i0, which has not yet been determined.
3. "i0" means any signal other than i0 Fig.7.5 layer 1 activation/deactivation state diagram - normal mode

Fig.7.5 Layer 1 Activation/Deaction State Diagram – TE/LT-T Normal Mode

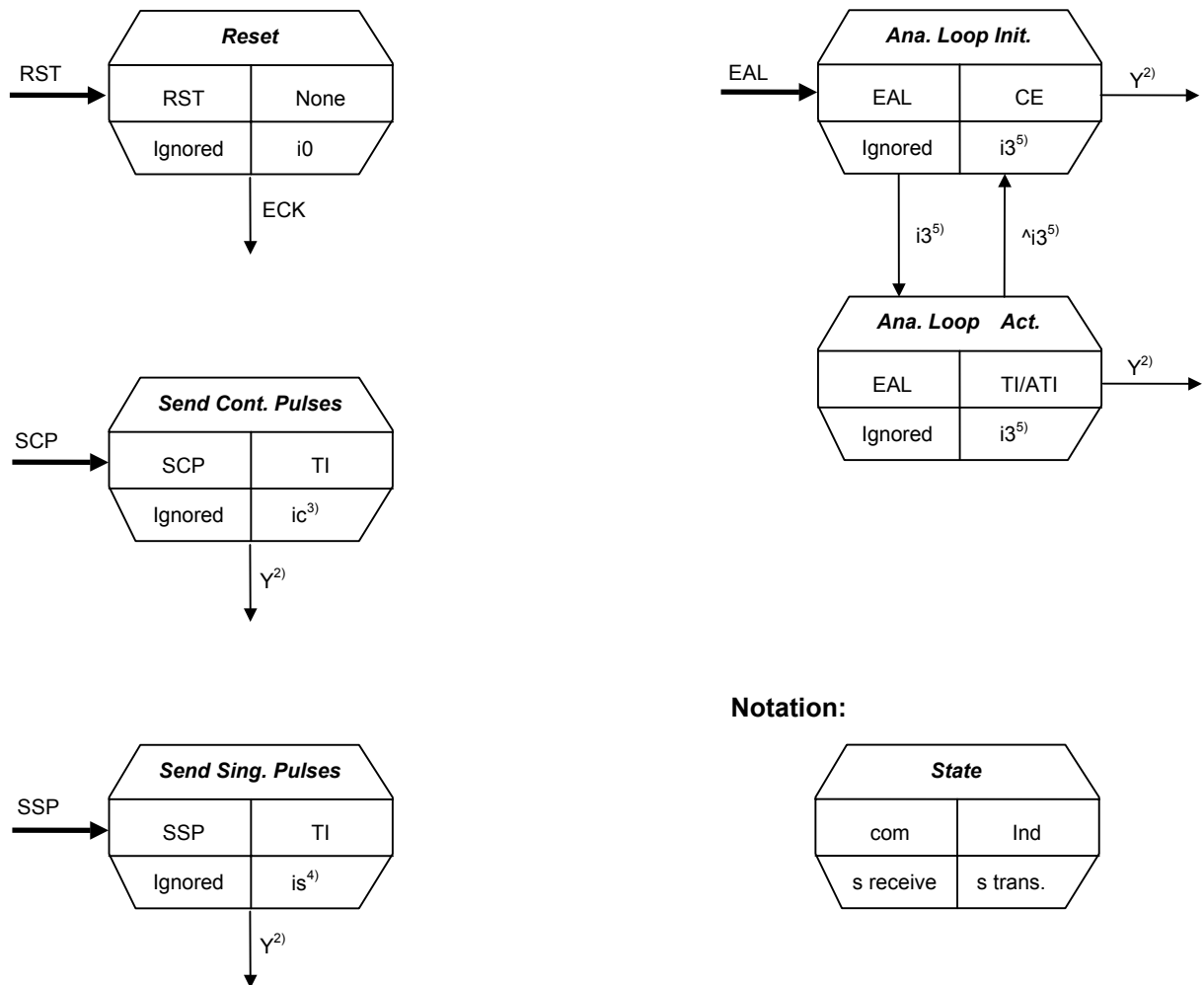

Notes:

1. RST can be issued at any state, while SCP, SCZ and EAL can be issued only at F3 or F7.
2. Y is one of the commands: ECK, DRC, RST.
3. Continuous pulses at 96 KHz.
4. Isolated pulses at 2 KHz.
5. The INFO 3 is transmitted internally only.

Fig.7.6 Layer 1 Activation/Deactivation State Diagram – TE/LT-T SPECIAL Mode



7.2.4 Layer 1 Activation /Deactivation in LT-S Mode

7.2.4.1 States Descriptions and Command/Indication Codes in LT-S Mode

G1 Deactivated

No any signal is detected on S interface and No any activation command is received in the C/I channel.

G2 Pending Activation

If INFO1 is detected on S interface or an ARD command is received from layer2, the W6691 start to transmit INFO2. W6691 is waiting for receiving INFO3 from S interface. INFO2 is sent from W6691.

G3 Activated

W6691 receives INFO3, then, it enters G3 activated state. The INFO4 is transmitted in this state. When the synchronization is lost, W6691 switch to transmit INFO2 instead of INFO4 and wait for receiving INFO3 to get synchronization again.

G4 Pending Deactivation

This state is requested by DDR (deactivate request). If INFO0 is received during 16ms or an internal timer2 expiration, the layer1 responses DRIU indication for Layer2.

G4 Await Deactivated

The W6691 stays in this state and waits for DRIU report from layer2. If W6691 receives DRA command from layer2, it enters G1 state.

Test Mode Continuous Pulses

Continuous alternating 96 KHz pulses are sent.

Test Mode Single Pulses

Single alternating 2 KHz pulses are sent.

TABLE 7.4 LAYER 1 COMMAND CODES

COMMAND	SYM.	CODE	DESCRIPTION
Deactivate down request	DDR	0000	Deactive Layer1 and disable internal clocks
Send continuous pulses	SCP	0011	Send continuous pulses at 96 KHz
Send single pulses	SSP	0010	Send isolated pulses at 2 KHz
Activate request downstream	ARD	1000	Request Layer1 activate Info2/Info4 sent
Deactivate request assure	DRA	1111	Layer2 reponses Deactivate acknowledgement to make sure Layer1 can be deactivate
RESET	RST	0001	Initialize to G4 or G1 state

**TABLE 7.5 LAYER 1 INDICATION CODES**

INDICATION	SYM.	CODE	DESCRIPTIONS
Signal Synchronize	SSYU	0100	Received signal is not Info3 and try to re-synchronize again
Activate Request Indication Upstream	ARIU	1000	The INFO 1 signal detected is responded to Layer2.
Activate Indication upstream	AIU	1100	Synchronous receiver
Deactivate Request Indication Upstream	DRIU	1111	Timer2 expired Info 0 received during 25ms after deactivation request command
RESET Indication	RSTI	0001	Reset state indication
Test Indication	TI	0000	

7.2.4.2 States Transition Diagram in LT-S Mode

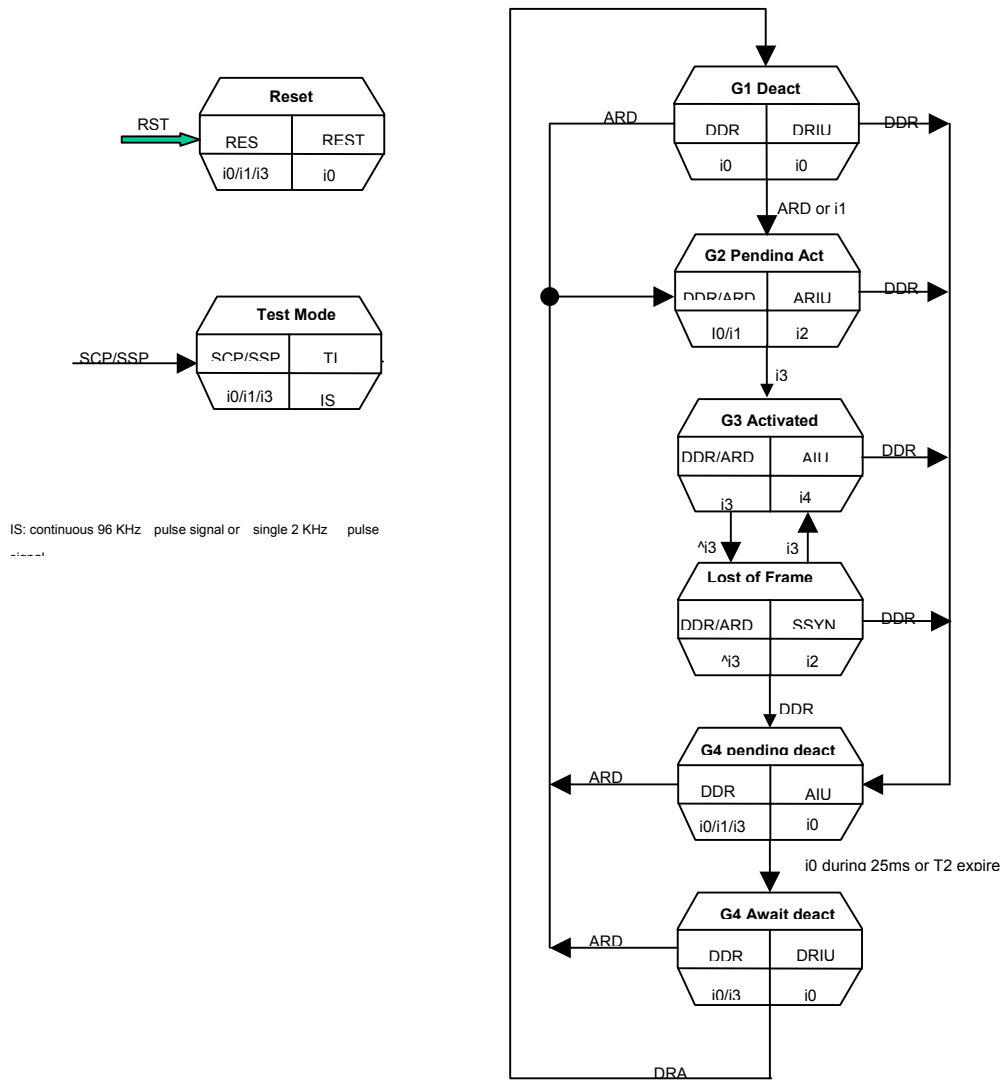

Fig.7.7 Layer 1 Activation/Deactivation State Diagram in LT-S



7.2.5 D Channel Access Control

The D channel access control includes collision detection and priority management. The collision detection is always enabled. The priority management procedure as specified in ITU-T I.430 is fully implemented in W6691.

A collision is detected if the transmitted D bit and the received echo bit do not match. When this occurs, D channel transmission is immediately stopped, and the echo channel is monitored to attempt the next D channel access.

There are two priority classes: class 1 and class 2. Within each class, there are normal and lower priority levels.

TABLE 7.8 D PRIORITY CLASSES

	NORMAL LEVEL	LOWER LEVEL
Priority class 1	8	9
Priority class 2	10	11

The selection of priority class is via the AR8/AR10 command. The following table summarizes the commands/indications used for setting the priority classes:

TABLE 7.9 D PRIORITY COMMANDS/INDICATIONS

COMMAND	SYM.	CODE	REMARKS
Activate request, set priority 8	AR8	1000	Activation command, set D channel priority to 8
Activate request, set priority 10	AR10	1001	Activation command, set D channel priority to 10
Indication	Abbr.		Remarks
Activate indication with priority 8	AI8	1100	Info 4 received, D channel priority is 8 or 9
Activate indication with priority 10	AI10	1101	Info 4 received, D channel priority is 10 or 11



7.2.6 Frame Alignment

The following sections describe the behavior of W6691 in respect to the CTS-2 conformance test procedures for frame alignment. Please refer to ETSI-TM3 Appendix B1 for detailed descriptions.

7.2.6.1 FAinfA_1fr

This test checks if TE does not lose frame alignment on receipt of one bad frame. The pattern for the bad frame is defined as IX_96 KHz. This pattern consists of alternating pulses at 96 KHz during the whole frame.

Device	Settings	Result
W6691	None	Pass

7.2.6.2 FAinfB_1fr

This test checks if TE does not lose frame alignment on receipt of one IX_I4noflag frame which has no framing and balancing bit.

Device	Settings	Result
W6691	None	Pass

7.2.6.3 FAinfD_1fr

This test checks if TE does not lose frame alignment on receipt of one IX-I4viol16 frame. The IX_I4viol16 frame remains at binary "1" until the first B2 bit which is bit position 16. The pulse sequences are: Framing bit, balancing bit, B2 bit, M bit, S bit, balancing bit. The TE should reflect the received F_A bit ($F_A="1"$) in the transmitted frame.

Device	Settings	Result
W6691	None	Pass

7.2.6.4 FAinfA_kfr

This is to test the number k of IX_96 KHz frames necessary for loss of frame alignment.

Device	Settings	Result
W6691	k = 2	Pass

7.2.6.5 FAinfB_kfr

This is to test the number k of IX_I4noflag frames necessary for loss of frame alignment.

Device	Settings	Result
W6691	k = 2	Pass



7.2.6.6 FAinfD_kfr

This is to test the number k of IX_I4noflag frames necessary for loss of frame alignment.

Device	Settings	Result
W6691	$k = 2$	Pass

7.2.6.7 Faregain

This is to test the number m of good frames necessary for regain of frame alignment. The TE regains frame alignment at $m+1$ frame.

The W6691 achieves synchronization after 5 frames, i.e $m = 4$.

Device	Settings	Result
W6691	$m = 4$	Pass

7.2.7 Multiframe Synchronization

As specified by ITU-T I.430, the Q bit is transmitted from TE to NT in the position normally occupied by the auxiliary framing bit (F_A) in one frame out of 5, whereas the S bit is transmitted from NT to TE. The S and Q bit positions and multiframe structure are shown in Table 7.10.

The functions provided by W6691 are:

- Multiframe synchronization: Synchronization is achieved when the M bit pattern has been correctly received during 20 consecutive frames starting from frame number 1.
Note: Criterion for multiframe synchronization is not defined in I.430 Recommendation.
- S bits receive and detect: When synchronization is achieved, the four received S bits in frames 1,6,11,16 are stored as S1 to S4 in the SQR register respectively. A change in the received four bits (S1-4) is indicated by an interrupt.
- Multiframe synchronization monitoring: Multiframe synchronization is constantly monitored. The synchronization state is indicated by the MSYN bit in the SQR register.
- Q bits transmit and F_A mirroring: When multiframe synchronization is achieved, the four bits Q1-4 stored in the SQXR register are transmitted as the four Q bits (F_A -bit position) in frames 1,6,11 and 16. Otherwise the F_A bit transmitted is a mirror of the received F_A -bit. At loss of synchronization, the mirroring is resumed at the next F_A -bit.
- The multiframe synchronization can be disabled by setting MFD bit in the D_MODE register.
- According to I.430 Recommendation, the S/Q channel can be used as operation and maintenance signalling channel. At transmitter, a S/Q code for a message shall be repeated at least six times or as many as necessary to obtain the desired response. At receiver, a message shall be considered received only when the proper codes is received three consecutive times.



TABLE 7.10 MULTIFRAME STRUCTURE IN S/T INTERFACE

FRAME NUMBER	NT-to-TE F _A -bit position	NT-to-TE M bit	NT-to-TE S bit	TE-to-NT F _A -bit position
1	ONE	ONE	S1	Q1
2	ZERO	ZERO	ZERO	ZERO
3	ZERO	ZERO	ZERO	ZERO
4	ZERO	ZERO	ZERO	ZERO
5	ZERO	ZERO	ZERO	ZERO
6	ONE	ZERO	S2	Q2
7	ZERO	ZERO	ZERO	ZERO
8	ZERO	ZERO	ZERO	ZERO
9	ZERO	ZERO	ZERO	ZERO
10	ZERO	ZERO	ZERO	ZERO
11	ONE	ZERO	S3	Q3
12	ZERO	ZERO	ZERO	ZERO
13	ZERO	ZERO	ZERO	ZERO
14	ZERO	ZERO	ZERO	ZERO
15	ZERO	ZERO	ZERO	ZERO
16	ONE	ZERO	S4	Q4
17	ZERO	ZERO	ZERO	ZERO
18	ZERO	ZERO	ZERO	ZERO
19	ZERO	ZERO	ZERO	ZERO
20	ZERO	ZERO	ZERO	ZERO
1	ONE	ONE	S1	Q1
2	ZERO	ZERO	ZERO	ZERO
etc.				



7.2.8 Test Functions

The W6691 provides loop and test functions as follows:

- Digital loop via DLP bit in D_MODE register: In the layer 2 block, the transmitted 2B+D data are internally looped (from HDLC transmitter to HDLC receiver), and in the PCM ports, the transmitted B channels are internally looped (from PCM inputs to PCM outputs). The clock timings are generated internally and are independent of the S bus timing. This loop function is used for test of PCM and higher layer functions, excluding layer 1. After hardware reset, W6691 will power down if S bus is not connected or if there is no signal on the S bus. In this case, the C/I command ECK must be issued to power up the chip.
- Analog loop via the C/I command EAL: The analog S interface transmitter is internally connected to the S interface receiver. When the receiver has synchronized itself to the internal INFO 3 signal, the message "Test Indication" or "Awake Test Indication" is delivered to the CIR register. No signal is transmitted over the S interface.

In this mode, the S interface awake detector is enabled. Therefore if a level (INFO 2/ INFO 4) is detected on the S interface, this will be reported by the "Awake Test Indication (ATI)" indication.

- Remote loopback via RLP bit in D_MODE register: The digital 2B data received from the S interface receiver is loopbacked to the S interface transmitter. The D channel is not looped. When RLP is enabled, layer 1 D channel is connected to HDLC port and DLP cannot be enabled.
- Transmission of special test signals via layer 1 command:
 - * Send Single Pulses (SSP): To send isolated single pulses of alternating polarity, with pulse width of one bit time, 250 μ S apart, with a repetition frequency of 2 KHz.
 - * Send Continuous Pulses (SCP): To send continuous pulses of alternating polarity, with pulse width of bit time. The repetition frequency is 96 KHz.

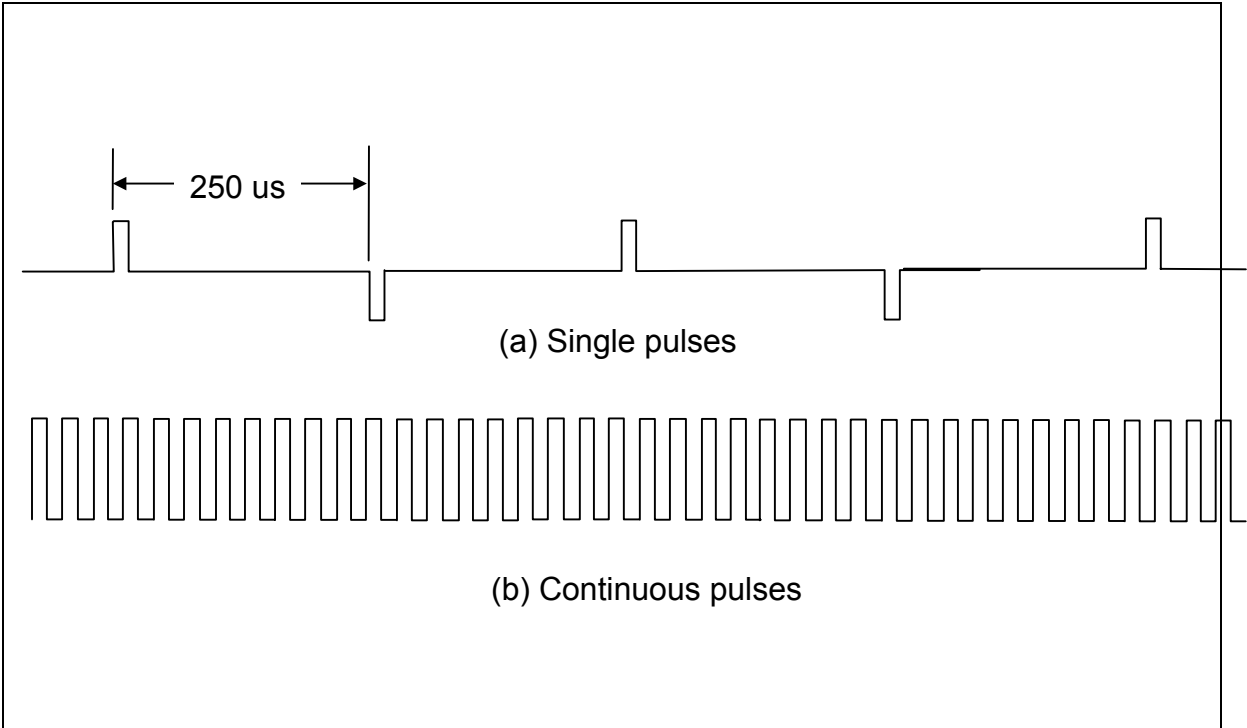

Fig.7.9 SSP and SCP Test Signals

7.3 B Channel Switching

W6691 provides five kinds of B channel switching function.

1. PCM and GCI bus Switch (SFCTL: PGSWH):

It determines the CODEC interface is to be operated in B channel.

- 1: PCM bus is selected to operate with CODEC.
- 0: GCI bus is selected to operate with CODEC.

2. PCM Remote Loop Back (SFCTL: PCRLP)

Setting this bit activates the PCM channel remote loopback function. The transmitted PCM data to PCM channel are looped to received PCM channel.

3. PXC PCM Cross-connect (SCFT: PXC)

This bit determines whether or not the PCM ports are cross-connected with the B channel ports. The setting of PXC is independent of the BSW1-0 bits.

PXC	Connection
0	PCM1 ↔ B1, PCM2 ↔ B2
1	PCM1 ↔ B2, PCM2 ↔ B1



4. B2SW1 / B2SW0 B2 channel Switch

These two bits determine B2 channel switch among PCM port, Layer1/GCI and Layer2.

00: Select B2 channel switch between Layer2 and Layer1/GCI.

01: Select B2 channel switch between Layer1/GCI and PCM.

10: Select B2 channel switch between PCM and Layer2.

5. B1SW1 / B1SW0 B1 channel Switch

These two bits determine B1 channel switch among PCM port, Layer1/GCI and Layer2.

00: Select B1 channel switch between Layer2 and Layer1/GCI.

01: Select B1 channel switch between Layer1/GCI and PCM.

10: Select B1 channel switch between PCM and Layer2.

7.4 PCM Port

There are two PCM ports in W6691. Data is valid when respective PFCK is HIGH. The frame synchronization clocks (PFCK1-2) are 8 KHz and the bit synchronization clock (PBCK) is 1.536 MHz.

7.5 Channel HDLC Controller

There are two HDLC protocols that are used for ISDN layer 2 functions: LAPD and LAPB. Their frame formats are shown below.

LAPB modulo 8:

flag (1 octet)	address (1octet)	control (1octet)	information (0 or N octets)	FCS (2 octets)	flag (1 octet)
-------------------	---------------------	---------------------	--------------------------------	-------------------	-------------------

Control field bits	7	6	5	4	3	2	1	0
I frame	N(R)		P	N(S)				0
S frame	N(R)		P/F	S	S	0	1	
U frame	M	M	M	P/F	M	M	1	1

**LAPB modulo 128:**

flag (1 octet)	address (1 octet)	control (1 or 2 octets)	information (0 or N octets)	FCS (2 octets)	flag (1 octet)
-------------------	----------------------	----------------------------	--------------------------------	-------------------	-------------------

	1st octet								2nd octet							
Control field bits	7	6	5	4	3	2	1	0	7	6	5	4	3	2	1	0
I frame	N(S)							0	N(R)							P
S frame	X	X	X	X	S	S	0	1	N(R)							P/F
U frame	M	M	M	P/F	M	M	1	1								

LAPD : modulo 128 only

flag (1 octet)	address (2 octets)	control (2 octets)	information (0 or N octets)	FCS (2 octets)	flag (1 octet)
-------------------	-----------------------	-----------------------	--------------------------------	-------------------	-------------------

	1st octet								2nd octet							
Control field bits	7	6	5	4	3	2	1	0	7	6	5	4	3	2	1	0
I frame	N(S)							0	N(R)							P/F
S frame	0	0	0	0	S	S	0	1	N(R)							P/F
U frame	M	M	M	P/F	M	M	1	1								

7.5.1 D Channel Message Transfer Modes

The D channel HDLC controller operates in transparent mode.

Characteristics:

- Receive frame address recognition
- Address comparison maskable bit-by-bit
- Flag generation / deletion
- Zero bit insertion/ deletion
- Frame Check Sequence (FCS) generation/ check with CRC_ITU-T

Note. The LAPD protocol uses the CRC_ITU-T for Frame Check Sequence. The polynomial is $X^{16} + X^{12} + X^5 + 1$.



For address recognition, the W6691 provides four programmable registers for individual SAPI and TEI values, SAP1-2 and TEI1-2, plus two fixed values for group SAPI and TEI, SAPG and TEIG. The SAPG equals 02H(C/R = 1) or 00H(C/R = 0) which corresponds to SAPI = 0. The TEIG equals FFH which corresponds to TEI = 127. Incoming frame with 1st address octet = (SAP1 or SAP2 or SAPG) and 2nd address octet = (TEI1 or TEI2 or TEIG) will be stored in the receive FIFO, with flag and FCS fields being discarded and stuffed bits being removed.

The valid address combinations are:

- SAP1 and TEI1
- SAP1 and TEI = 127
- SAP2 and TEI2
- SAP2 and TEI = 127
- SAPI = 0 and TEI1
- SAPI = 0 and TEI2
- SAPI = 0 and TEI = 127

The receive frame address comparisons can be disabled (masked) per bit basis by setting the D_SAM and D_TAM registers, but comparisons with the SAPG or TEIG cannot be disabled.

7.5.2 Reception of Frames in D Channel

A 128-byte FIFO is provided in the receive direction. The data movement is handled by interrupts.

There are two interrupt sources: Receive Message Ready (D_RMR) and Receive Message End (D_RME). The D_RMR interrupt indicates that at least 64 bytes of data have been received and the message/ frame is not ended. Upon D_RMR interrupt, the microprocessor reads out 32 bytes of data from the FIFO. The D_RME interrupt indicates the last segment of a message or a message with length ≤ 32 bytes has been received. The length of data is less than or equal to 32 and is specified in the D_RBCL register.

If the length of the last segment of message is 32, only D_RME interrupt is generated and the RBC4-0 bits in D_RBCL register are 000000B.

The data between the opening flag and the CRC field are stored in D_RFIFO. For LAPD frame, this includes the address field, control field and information field.

When a D_RMR or D_RME interrupt is generated, the micro-processor must read out the data from D_RFIFO and issues the Receive Message Acknowledgement command (D_CMDR: RACK bit) to explicitly acknowledge the interrupt. The microprocessor must handle the interrupt before more than 32 bytes of data are received. This corresponds to a maximum microprocessor reaction time of 16 ms at 16 kbps data rate.

If the microprocessor is late in handling the interrupt, the incoming additional bytes will result in a "data overflow" interrupt and status bit.



7.5.3 Transmission of Frames in D Channel

A 64-byte FIFO is provided in the transmit direction. If the transmit FIFO is ready (which is indicated by a D_XFR interrupt), the micro-processor can write up to 32 bytes of data into the FIFO and use the XMS command bit to start frame transmission. The HDLC transmitter sends the opening flag first and then sends the data in the transmit FIFO.

The microprocessor must write the address, control and information field of a frame into the transmit FIFO.

Every time no more than 32 bytes of data are left in the transmit FIFO, the transmitter generates a D_XFR interrupt to request another block of data. The microprocessor can then write further data to the transmit FIFO and enables the subsequent transmission by issuing an XMS command.

If the data written to the FIFO is the last segment of a frame, the microprocessor issues the XME (Transmit Message End) and XMS command bits to finish the frame transmission. The transmitter then transmits the data in the FIFO and appends CRC and closing flag.

If the microprocessor fails to respond the D_XFR interrupt within a given time (16 ms), a data underrun condition will occur. The W6691 will automatically reset the transmitter and send inter frame time fill pattern (all 1's) on D channel. The microprocessor is informed about this condition via an XDUN (Transmit Data Underrun) interrupt in D_EXIR register. The microprocessor must wait until transmit FIFO ready (via XFR interrupt), re-write data, and issue XMS command to re-transmit the data.

It is possible to abort a frame by issuing a D_CMDR: XRST (D channel Transmitter Reset) command. The XRST command resets the transmitter and causes a transmit FIFO ready condition.

After the microprocessor has issued the XME command, the successful termination of transmission is indicated by an D_XFR interrupt.

The inter-frame time fill pattern must be all 1's, according to ITU-T I.430.

Collisions which occur on the D channel of S interface will cause an D_EXIR: XCOL interrupt. A XRST (Transmitter Reset) command must be issued and software must wait until transmit FIFO ready (via XFR interrupt), re-write data, and issue XMS command to re-transmit the data.

7.6 GCI Mode Serial Interface Bus

The GCI is a generalization and enhancement of the general purpose, serial interface bus. The channel structure of the GCI mode is depicted below. The timing is compatible with Siemens's IOM-2 mode.

TE Mode Timing

TE mode contains three channels. The structure of TE mode is show in Fig7.10.

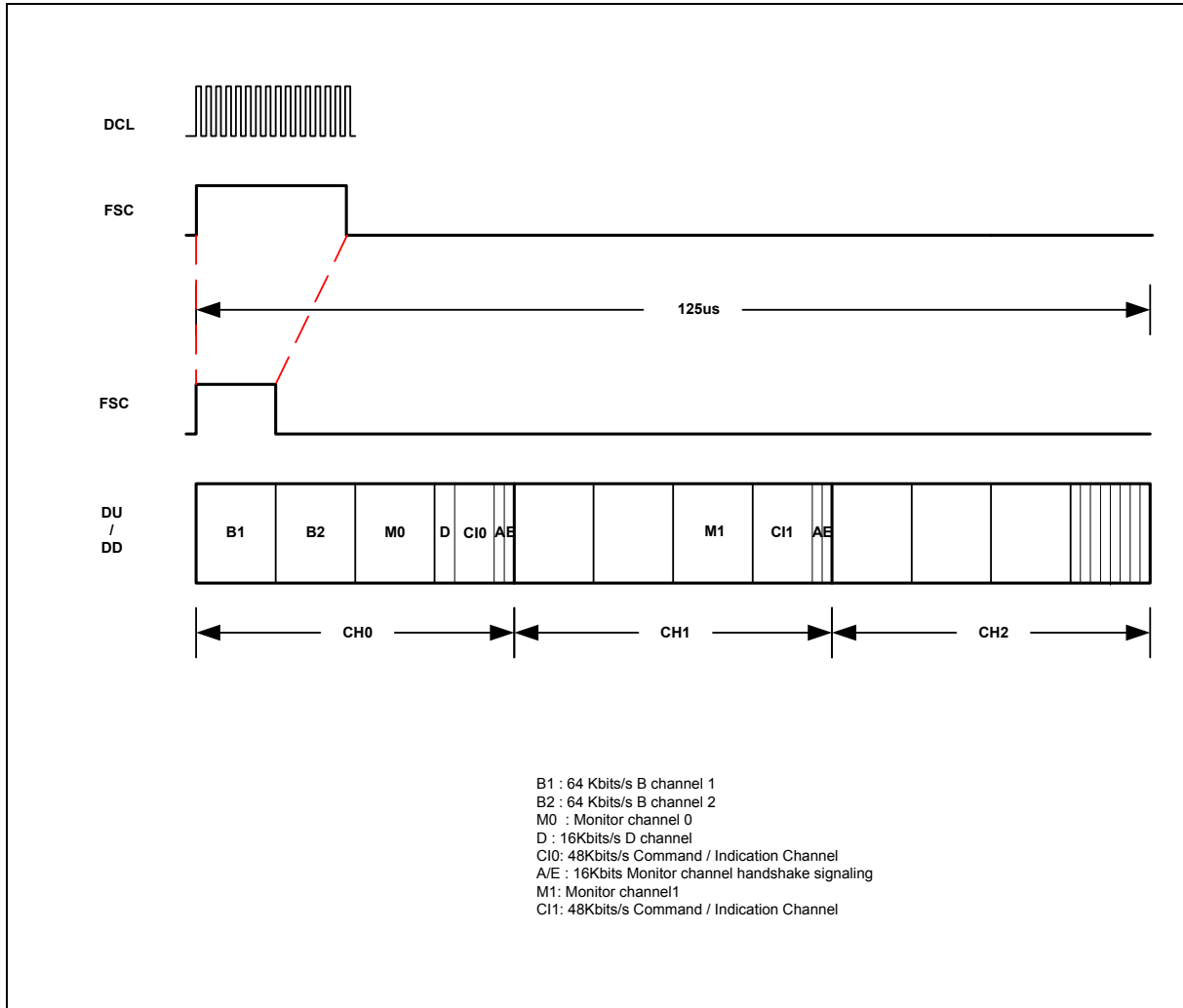

Fig.7.10 GCI TE Mode Channel Structure

Non-TE mode Timing

Non -TE mode timing is used LT-S and LT-T applications. The frame contains eight channel (ch0 ~ ch7) GCI channels. All structure of the eight channels shown in Fig7.11 is the same.

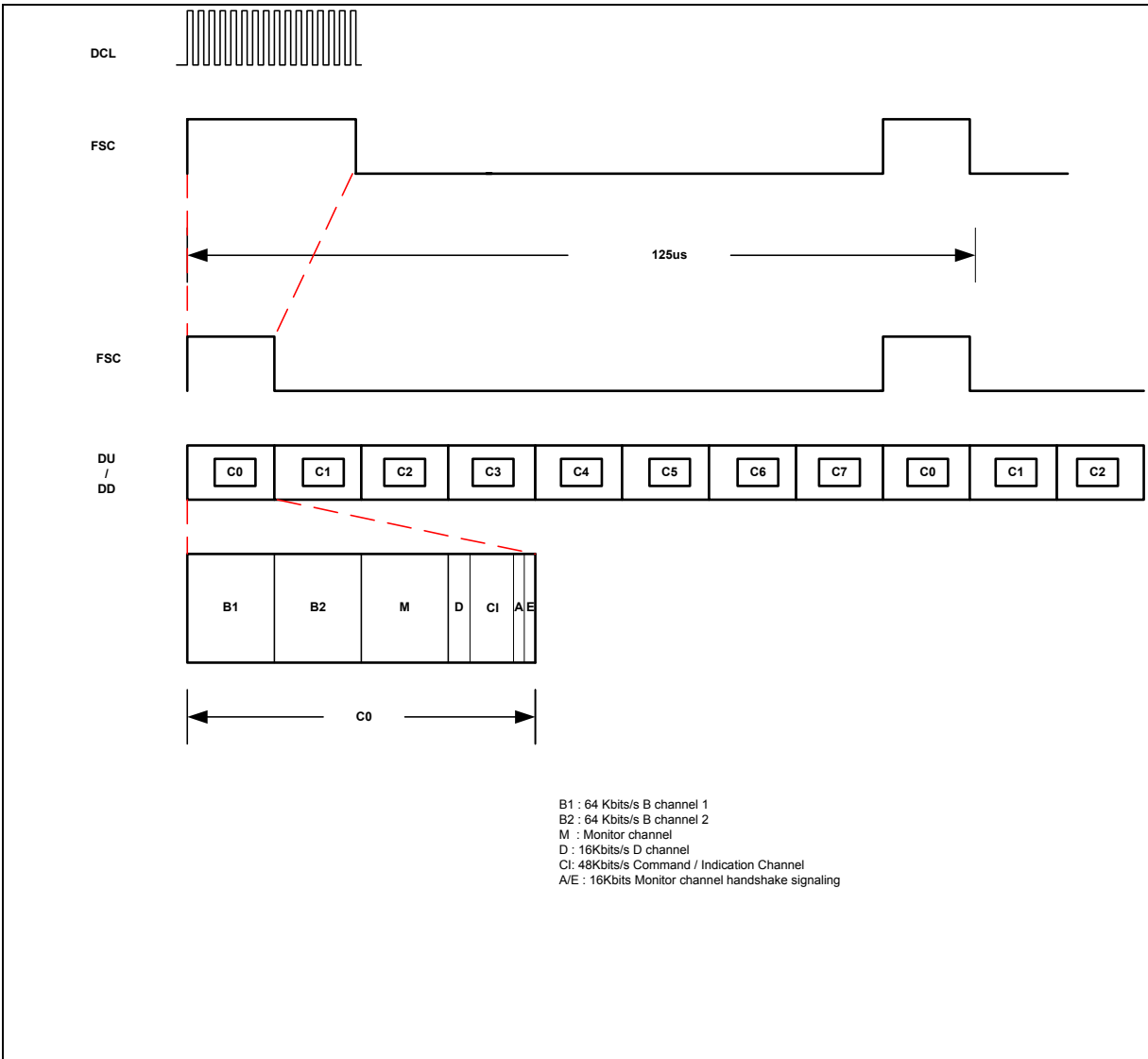

Fig.7.11 GCI Non -Terminal Mode Channel Structure



7.6.1 GCI Mode C/I Channel Handling

1) CI0 channel

The Command/Indication channel 0 carries real-time status information between the W6691 and another device connected to the GCI bus interface.

One CI0 channel conveys the commands and indications between a layer 1 device and layer 2 device. This C/I0 channel is accessed via register CIR (in receive direction, layer 1 to layer 2) and register CIX (in transmit direction, layer 2 to layer 1). The C/I code is 4-bit long.

- In the receive direction, the code from layer 1 is continuously monitored, with an interrupt being generated anytime a change occurs. A new code must be found in two consecutive GCI frames to be considered valid and to trigger a C/I code change interrupt status (double last look criterion).
- In the transmit direction, the code written in CIX is continuously transmitted in the channel.

2) CI1 channel

CI1 channel is responsible for real time communication between W6691 and other non-layer1 peripheral devices. It consists of six bits. This channel can be used only in TE mode. C1X and C1R are used for CI1 channel access in both of transmitting and receiving direction. CI1 code changed is indicated by an interrupt without double last look criterion. This interrupt will set CI1 bit in GCI_EXIR.

7.6.2 GCI Mode Monitor Channel Handling

The Monitor channel protocol is a handshake protocol used for high speed information exchange between the W6691 and other devices. The Monitor channel is necessary for:

- Programming and controlling devices attached to the GCI interface.
- Data exchange between two microprocessor systems attached to two different devices on one GCI backplane. Use of the Monitor channel avoids the necessity of a dedicated serial communication path between two systems.

The Monitor channel operates on an asynchronous basis. While data transfers on the bus take place synchronized to frame sync, the flow of data is controlled by a handshake procedure using the Monitor Channel Receiver (MOR) and Monitor Channel Transmit (MOX) bits. When data is placed into the Monitor channel and the "A" bit is activated. This data will be transmitted repeatedly once per 8 KHz frame until the transfer is acknowledged via the "E" bit.

The microprocessor may either enforce a 1 (idle state) in "E", "A" bit by setting the control bit MRC or MXC (MOCR register) to 0, or enable the control of these bits internally by the W6691 according to the Monitor channel protocol. Thus, before a data exchange can begin, the control bit MRC, or MXC should be set to 1 by the microprocessor.

The relevant status bits are:

- For the reception of Monitor data: MDR (Monitor Channel Data Received) \Leftrightarrow MER (Monitor Channel End of Reception)
- For the transmission of Monitor data: MDA (Monitor Channel Data Acknowledged) \Leftrightarrow MAB (Monitor Channel Data Abort)



About the status bit MAC(Monitor Channel Transmit Active) indicates whether a transmission is progress.

- If set MAC = 0, the previous transmission has been terminated. Before starting a transmission, the microprocessor should verify that the transmitter is inactive.
- If set MAC = 1, after having written data into the Monitor Transmit Channel (MOX) register, the microprocessor sets this bit to 1. This enables the "A" bit to go active (0), indicating the presence of valid Monitor data (contents of MOX) in the corresponding frame.

The receiving device stores the Monitor byte in its MOR (Monitor Receive Channel) and generates a MDR (Monitor Channel Data Receive) interrupt status. Alerted by the MDR interrupt, the microprocessor reads the MOR register. When it is ready to accept data, it sets the "E" control bit MRC to 1 to enable the receiver to store succeeding Monitor channel bytes and acknowledge them according to the Monitor channel protocol. In addition, it enables other Monitor channel interrupts by setting Monitor Channel Interrupt Enable to 1.

The first Monitor channel byte is acknowledged by the receiving device setting the "E" bit to 0. This causes a MDA (Monitor Channel Data Acknowledge) interrupt status at the transmitter. A new Monitor channel data byte can now be written by the microprocessor in MOX register. The "A" bit is still in the active (0) state. The transmitter indicates a new byte in the Monitor channel by returning the "A" bit active after sending it once in the inactive state. The receiver stores the Monitor channel byte in MOR register and generates a new MDR interrupt status. When the microprocessor has read the MOR register, the receiver acknowledges the data by returning the "E" bit active after sending it once in the inactive state. This in turn causes the transmitter to generate a MDA interrupt status. This "MDA interrupt \Rightarrow write data \Rightarrow MDR interrupt \Rightarrow read data \Rightarrow MDA interrupt " handshake procedure is repeated as long as the transmitter has data to send.

When the last byte has been acknowledged by the receiver (MDA interrupt status), the microprocessor sets the Monitor channel Transmit Control bit MXC to 0. This enforces an inactive (1) state in the "A" bit. Two frames of "A" inactive signifies the end of a message. Thus, a MER (Monitor channel End of Reception) interrupt status is generated by the receiver when the "A" bit is received in the inactive state in two consecutive frames. As a result, the microprocessor sets the "E" bit control bit MRC to 0, which in turn enforces an inactive state in the "E" bit. This marks the end of the transmission, making the MAC (Monitor channel Active) bit return to 0.

During a transmission process, it is possible for the receiver to ask a transmission to be aborted by sending an inactive "E" bit value in two consecutive frames. This is effected by the microprocessor writing the "E" bit control bit MRC to 0. An aborted transmission is indicated by a MAB (Monitor Channel Data Abort) interrupt

7.7 8-bit Microprocessor Interface

At power up, the reset pin RST# must be asserted to initialize the chip. At rising edge of RST#, data value at MBS pin determines the operation modes: HIGH for Intel bus mode, LOW for Motorola bus mode.



8. REGISTER DESCRIPTIONS

8.1 D Channel HDLC Controller Register Address Map

TABLE 8.1 D CHANNEL HDLC CONTROLLER REGISTER ADDRESS MAP

OFFSET	ACCESS	REGISTER NAME	DESCRIPTION
00	R	D_RFIFO	D channel receive FIFO
01	W	D_XFIFO	D channel transmit FIFO
02	W	D_CMDR	D channel command register
03	R/W	D_MODE	D channel mode control
04	R_clear	ISTA	Interrupt status register
05	R/W	IMASK	Interrupt mask register
06	R_clear	D_EXIR	D channel extended interrupt
07	R/W	D_EXIM	D channel extended interrupt mask
08	Reserved		
09	Reserved		
0A	R	D_XSTA	D channel transmit status
0B	R	D_RSTA	D channel receive status
0C	Reserved		
0D	Reserved		
0E	R/W	D_SAM	D channel address mask 1
0F	R/W	D_SAP1	D channel individual SAPI 1
10	R/W	D_SAP2	D channel individual SAPI 2
11	R/W	D_TAM	D channel address mask 2
12	R/W	D_TEI1	D channel individual TEI 1
13	R/W	D_TEI2	D channel individual TEI 2
14	Reserved		
15	Reserved		
16	R	D_RBCH	D channel receive frame byte count high
17	R	D_RBCL	D channel receive frame byte count low



8.2 GCI Bus Control Register Address Map

TABLE 8.2 GCI BUS CONTROL REGISTER ADDRESS MAP

OFFSET	ACCESS	REGISTER NAME	DESCRIPTION
18	W	CSEL	Gci Bus cahnnel selection register
19			Reserved
1A	R/W	CIR	Command/Indication receive
1B	R/W	CIX	Command/Indication transmit
1C	R	SQR	S/Q channel receive register
1D	R/W	SQX	S/Q channel transmit register
1E			Reserved
1F			Reserved
20	R/W	MO0R	Monitor receive channel 0
21	R/W	MO0X	Monitor transmit channel 0
22	R_clear	MO0I	Monitor channel 0 interrupt
23	R/W	MO0C	Monitor channel 0 control register
24			Reserved
25			Reserved
26	R/W	GCR	GCI mode control/ status register
27	R	MO1R	Monitor receive channel 1
28	R/W	MO1X	Monitor transmit channel 1
29	R_clear	MO1I	Monitor channel 1 interrupt
2A	R/W	MO1C	Monitor channel 1 control
2B			Reserved
2C			Reserved
2D			Reserved
2E			Reserved
2F			Reserved
30			Reserved
31	R	CI1R	GCI CI1 indication
32	R/W	CI1X	GCI CI1 command
33			Reserved
34	R_clear	GCI_EXIR	GCI extended interrupt
35	R/W	GCI_EXIM	GCI extended interrupt mask



8.3 Miscellaneous Register Address Map

TABLE 8.3 MISCELLANEOUS REGISTER ADDRESS MAP

OFFSET	ACCESS	REGISTER NAME	DESCRIPTION
36			Reserved
37			Reserved
38	R/W	TIMR1	Timer 1
39	R/W	TIMR2	Timer 2
3A	R/W	PCR	Peripheral control register
3B	R/W	PIODR	Peripheral I/O data register
3C	R/W	SFCTL	Switch function controll register
3D	R/W	ACTL1	Auxiliary control register 1
3E	R/W	ACTL2	Auxiliary control register 2
3F	R/W	ACTL3	Auxiliary control register 3



8.4 D Channel HDLC Controller Register Memory Map

TABLE 8.4 D CHANNEL HDLC CONTROLLER REGISTER MEMORY MAP

Offset	R/W	Name	7	6	5	4	3	2	1	0
00	R	D_RFIFO								
01	W	D_XFIFO								
02	W	D_CMDR	RACK	RRST	0	STT1	XMS	0	XME	XRST
03	R/W	D_MODE	0	RACT	XACT	S_RLPD	0	MFD	L2_DLP	S_RLP
04	R_clr	ISTA	D_RMR	D_RME	D_XFR	INT1	INT0	D_EXI	B1_EXI	B2_EXI
05	R/W	IMASK	D_RMR	D_RME	D_XFR	INT1	INT0	D_EXI	B1_EXI	B2_EXI
06	R_clr	D_EXIR	RDOV	XDUN	XCOL	TIN2	GCI	ICC	T1EXP	SCC
07	R/W	D_EXIM	RDOV	XDUN	XCOL	TIN2	GCI	ICC	T1EXP	SCC
08			Reserved							
09			Reserved							
0A	R	D_XSTA	XDOW	0	XBZ	0	0	0	0	0
0B	R	D_RSTA	0	RDOV	CRCE	RMB	0	0	0	0
0C			Reserved							
0D			Reserved							
0E	R/W	D_SAM	SAM7	SAM6	SAM5	SAM4	SAM3	SAM2	SAM1	SAM0
0F	R/W	D_SAP1	SA17	SA16	SA15	SA14	SA13	SA12	SA11	SA10
10	R/W	D_SAP2	SA27	SA26	SA25	SA24	SA23	SA22	SA21	SA20
11	R/W	D_TAM	TAM7	TAM6	TAM5	TAM4	TAM3	TAM2	TAM1	TAM0
12	R/W	D_TEI1	TA17	TA16	TA15	TA14	TA13	TA12	TA11	TA10
13	R/W	D_TEI2	TA27	TA26	TA25	TA24	TA23	TA22	TA21	TA20
14			Reserved							
15			Reserved							
16	R	D_RBCH	VN1	VN0	LOV	RBC12	RBC11	RBC10	RBC9	RBC8
17	R	D_RBCL	RBC7	RBC6	RBC5	RBC4	RBC3	RBC2	RBC1	RBC0

8.5 GCI Bus Register Memory Map

TABLE 8.5 GCI BUS REGISTER MEMORY MAP

Offset	R/W	Name	7	6	5	4	3	2	1	0
18	R/W	CSEL	0	0	0	0	0	CSEL2	CSEL1	CSEL0
19			Reserved							
1A	R	CIR	0	0	0	BAS	CORD3	CORD2	CORD1	CORD0
1B	R/W	CIX	0	0	0	BAC	CORD3	CORD2	CORD1	CORD0
1C	R	SQR	0	0	MSYN	0	S1	S2	S3	S4
1D	R/W	SQX	0	0	0	0	Q1	Q1	Q1	Q1
1E			Reserved							
1F			Reserved							
20	R	MO0R								
21	R/W	MO0X								
22	R_clr	MO0I	0	0	0	0	MDR0	MER0	MDA0	MAB0
23	R/W	MO0C	0	0	0	0	MRIE0	MRC0	MXIE0	MXC0
24			Reserved							
25			Reserved							
26	R	GCR	MAC0	MAC1	0	0	0	0	0	0
27	R	MO1R								
28	R/W	MO1X								
29	R_clr	MO1I	0	0	0	0	MDR1	MER1	MDA1	MAB1
2A	R/W	MO1C	0	0	0	0	MRIE1	MRC1	MXIE1	MXC1
2B			Reserved							
2C			Reserved							
2D			Reserved							
2E			Reserved							
2F			Reserved							
30			Reserved							
31	R	CI1R	0	0	CI1R_6	CI1R_5	CI1R_4	CI1R_3	CI1R_2	CI1R_1
32	R/W	CI1X	0	0	CI1X_6	CI1X_5	CI1X_4	CI1X_3	CI1X_2	CI1X_1
33			Reserved							
34	R_clr	GCI_EXIR	0	0	0	MO1C	MO0C	0	0	CI1
35	R/W	GCI_EXIM	1	1	1	MO1C	0	0	0	CI1



8.6 Miscellaneous Register Memory Map

TABLE 8.6 MISCELLANEOUS REGISTER MEMORY MAP

Offset	R/W	Name	7	6	5	4	3	2	1	0
36			Reserved							
37			Reserved							
38	R/W	TIMR1	T1MD	CNT6	CNT5	CNT4	CNT3	CNT2	CNT1	CNT0
39	R/W	TIMR2	TMD	TIDLE	TCN5	TCN4	TCN3	TCN2	TCN1	TCN0
3A	R/W	PCR	0	0	0	0	OE3	OE2	OE1	OE0
3B	R/W	PIODR	0	0	0	0	IO3	IO2	IO1	IO0
3C	R/W	SFCTL	0	PGSWH	PCRLP	PXC	B2SW1	B2SW0	B1SW1	B1SW0
3D	R/W	ACTL1	0	0	SRST	0	0	0	OPS1	OPS0
3E	R/W	ACTL2	0	ACTL1	LC	0	SPU	0	0	0
3F	R/W	ACTL3	0	INTOL	0	0	0	0	0	0

8.7 D Channel HDLC Controller Register Description

8.7.1 D_ch receive FIFO D_RFIFO Read Address 00H

The D_RFIFO has a length of 64 bytes.

After a D_RMR interrupt, exactly 32 bytes are available.

After a D_RME interrupt, the number of bytes available equals RBC4-0 bits in the D_RBCL register.

8.7.2 D_ch transmit FIFO D_XFIFO Write Address 01H

The D_XFIFO has a length of 64 bytes.

After an D_XFR interrupt, up to 32 bytes of data can be written into this FIFO for transmission. At the first time transmission, up to 64 bytes of data can be written.

8.7.3 D_ch command register D_CMDR Write Address 02H

Value after reset: 00H

7	6	5	4	3	2	1	0
RACK	RRST	0	STT1	XMS	0	XME	XRST

**RACK Receive Acknowledge**

After a D_RMR or D_RME interrupt, the processor must read out the data in D_RFIFO and then sets this bit to acknowledge the interrupt. Writing “0” to this bit has no effect. If RACK bit is set to “1” for operating “Receiver Acknowledge”, It is not necessary to reset RACK bit to “0” by host processor. That is to say, once RACK is set to “1”, RACK bit is reset to “0” by W6691 automatically.

RRST Receiver Reset

Setting this bit resets the D_ch HDLC receiver and clears the D_RFIFO data. Writing “0” to this bit has no effect. If RRST bit is set to “1” for operating “Receiver Reset”, It is not necessary to reset RRST bit to “0” by host processor. That is to say, once RRST is set to “1”, RRST bit is reset to “0” by W6691 automatically.

STT1 Start Timer 1

The timer 1 is started when this bit is set to one. The timer is stopped when it expires or by a write of the TIMR1 register. Writing “0” to this bit has no effect. If SST1 bit is set to “1” for operating “Start Timer1”, It is not necessary to reset STT1 bit to “0” by host processor. That is to say, once STT1 is set to “1”, STT1 bit is reset to “0” by W6691 automatically.

XMS Transmit Message Start/Continue

Setting this bit will start or continue the transmission of a frame. The opening flag is automatically added by the HDLC controller. Writing “0” to this bit has no effect. If XMS bit is set to “1” for operating “Transmit Message Start/Continue”, It is not necessary to reset XMS bit to “0” by host processor. That is to say, once XMS is set to “1”, XMS bit is reset to “0” by W6691 automatically.

XME Transmit Message End

Setting this bit indicates the end of frame transmission. The D_ch HDLC controller automatically appends the CRC and the closing flag after the data transmission. Writing “0” to this bit has no effect. If XME bit is set to “1” for operating “Transmit Message End”, It is not necessary to reset XME bit to “0” by host processor. That is to say, once XME is set to “1”, XME bit is reset to “0” by W6691 automatically.

Note: If the frame \leq 32 bytes, XME plus XMS commands must be issued at the same time.

XRST Transmitter Reset

Setting this bit resets the D_ch HDLC transmitter and clears the D_XFIFO. The transmitter will send inter frame time fill pattern (which is 1's) immediately. This command also results in a transmit FIFO ready condition. Writing “0” to this bit has no effect. If XRST bit is set to “1” for operating “Transmit Reset”, It is not necessary to reset XME bit to “0” by host processor. That is to say, once XRST is set to “1”, XRST bit is reset to “0” by W6691 automatically.



8.7.4 D_ch Mode Register D_MODE Read/Write Address 03H

Value after reset: 00H

7	6	5	4	3	2	1	0
0	RACT	XACT	0	S_RLPD	MFD	L2_DLP	S_RLP

RACT Receiver Active

Setting this bit activates the D_ch HDLC receiver. This bit can be read. The receiver must be in active state in order to receive data.

Note: The receiver is deactive after hardware reset or software reset.

XACT Transmitter Active

Setting this bit activates the D_ch HDLC transmitter. This bit can be read. The transmitter must be in active state in order to transmit data.

Note: The transmitter is deactive after hardware reset or software reset.

S_RLPD S Interface Remote Loopback with D channel Loopback

Setting this bit to "1" activates the remote loopback function. The received 2B channels from the S interface are looped to the transmitted 2B channels of S interface. The received D channel from the S interface is also looped to transmitted D channel of S interface in the loopback function.

MFD Multiframe Disable

This bit is used to enable or disable the multiframe structure on S/T interface:

0: Multiframe is enabled

1: Multiframe is disabled

L2_DLP Layer2 Digital Loopback

Setting this bit activates the layer2 digital loopback function. The transmitted digital 2B+D channels are looped to the received 2B+D channels. Note that after hardware reset, the internal clocks will turn off if the S bus is not connected or if there is no signal on the S bus. In this case, the C/I command ECK must be issued to enable loopback function.

S_RLP S Interface Remote Loopback

Setting this bit to "1" activates the remote loopback function. The received 2B channels from the S interface are looped to the transmitted 2B channels of S interface. The received D channel from the S interface is **not** looped to transmitted D channel of S interface in this loopback function.



8.7.5 Interrupt Status Register ISTA Read_clear Address 04H

Value after reset: 00H

7	6	5	4	3	2	1	0
D_RMR	D_RME	D_XFR	INT1	INT0	D_EXI	B1_EXI	B2_EXI

D_RMR D_ch Receive Message Ready

A 64-byte data is available in the D_RFIFO. The frame is not complete yet.

D_RME D_ch Receive Message End

The last part of a frame with length > 32 bytes or a whole frame with length ≤ 32 bytes has been received. The whole frame length is obtained from D_RBCH + D_RBCL registers. The length of data in the D_RFIFO equals:

data length = RBC4-0 if RBC4-0 ≠ 0

data length = 32 if RBC4-0 = 0

D_XFR D_ch Transmit FIFO Ready

This bit indicates that the transmit FIFO is ready to accept data. Up to 32 bytes of data can be written into the D_XFIFO.

An D_XFR interrupt is generated in the following cases:

- After an XMS command, when ≥32 bytes of XFIFO is empty
- After an XMS together with an XME command is issued, when the whole frame has been transmitted
- After an XRST command
- After hardware reset or software reset

INT1 INT1 Interrupt

If the INT1 bit is set to "1", this bit indicates that interrupt trigger occurs at INT1 pin.

INT0 INT0 Interrupt

If the INT0 bit is set to "1", this bit indicates that interrupt trigger occurs at INT0 pin.

D_EXI D_ch Extended Interrupt

This bit indicates that at least one interrupt bit is set in D_EXIR register.

Note: A read of the ISTA register clears all bits except D_EXI, D_EXI bit is cleared when all bits in D_EXIR register are cleared.

B1_EXI B1_ch Extended Interrupt

This bit indicates that at least one interrupt bit has been set in B1_EXIR register.



B2_EXI B2_ch Extended Interrupt

This bit indicates that at least one interrupt bit has been set in B2_EXIR register.

8.7.6 Interrupt Mask Register IMASK Read/Write Address 05H

Value after reset: FFH

7	6	5	4	3	2	1	0
D_RMR	D_RME	D_XFR	INT1	INT0	D_EXI	B1_EXI	B2_EXI

Setting the bit to "1" masks the corresponding interrupt source in ISTA register. Masked interrupt status bits are read as zero. They are internally stored and pending until the mask bits are zero.

Note: Setting the D_EXI bit to "1" masks the interrupts in D_EXIR register.

8.7.7 D_ch Extended Interrupt Register D_EXIR Read_clear Address 06H

Value after reset: 00H

7	6	5	4	3	2	1	0
RDOV	XDUN	XCOL	TIN2	GCI	ICC	T1EXP	SCC

RDOV Receive Data Overflow

Frame overflow (too many short frames) or data overflow occurs in the receive FIFO. In data overflow, the incoming data will overwrite the data in the receive FIFO. If RDOV interrupt occurs, software has to reset the receiver and discard the data received.

XDUN Transmit Data Underrun

This interrupt indicates the D_XFIFO has run out of data. In this case, the W6691 will automatically reset the transmitter and send the inter frame time fill pattern (all 1's) on D channel. The microprocessor must wait until transmit FIFO ready (via XFR interrupt), re-write data, and issue XMS command to re-transmit the data.

XCOL Transmit Collision

This bit indicates a collision on the S-bus has been detected. W6691 will automatically reset the transmitter and software must wait until transmit FIFO ready (via XFR interrupt), then, re-write data, and issue XMS command to re-transmit the data.

TIN2 Timer 2 Expiration

This bit is set when Timer 2 counts down to zero.

GCI GCI Interrupt

This bit is set when at least one bit is set in GCI_EXIR register.

ICC Indication Channel Change



A change in the layer 1 indication code is detected. The actual value can be read from CIR registers.

T1EXP **Timer 1 Expiration**

Expiration occurs in the Timer 1.

SCC **S Channel Change**

A change in multi-frame S channel is detected. The actual value can be read from SQR registers.

8.7.8 D_ch Extended Interrupt Mask Register D_EXIM Read/Write Address 07H

Value after reset: FFH

7	6	5	4	3	2	1	0
RDOV	XDUN	XCOL	TIN2	GCI	ICC	T1EXP	SCC

Setting the bit to "1" masks the corresponding interrupt source in D_EXIR register. Masked interrupt status bits are read as zero. They are internally stored and pending until the mask bits are zero.

Note: All the interrupts in D_EXIR will be masked if the IMASK:D_EXI bit is set to "1".

8.7.9 D_ch Transmitter Status Register D_XSTA Read Address 0AH

Value after reset: 00H

7	6	5	4	3	2	1	0
XDOW	0	XBZ	0	0	0	0	0

XDOW **Transmit Data Overwritten**

At least one byte of data has been overwritten in the D_XFIFO. This bit is set by data overwritten condition and is cleared only by XRST command.

XBZ **Transmitter Busy**

This bit indicates the D_HDLC transmitter is busy. The XBZ bit is set to "1" from the transmission of opening flag to the transmission of closing flag.

8.7.10 D_ch Receive Status Register D_RSTA Read Address 0BH

Value after reset: 20H

7	6	5	4	3	2	1	0
0	RDOV	CRCE	RMB	0	0	0	0

RDOV **Receive Data Overflow**

A "1" indicates that the D_RFIFO is overflow. The incoming data will overwrite data in the receive FIFO. The data overflow condition will set both the status and interrupt bits. ***It is recommended that software must read the RDOV bit after reading data from D_RFIFO when RMR or RME interrupt***



occurs. The software must abort the data and issue a RRST command to reset the receiver if RDOV = 1. The frame overflow condition will not set this bit.

CRCE CRC Error

This bit indicates the result of frame CRC check:

0: CRC correct

1: CRC error

RMB Receive Message Aborted

A "1" means that a sequence of seven 1's was received and the frame is aborted. Software must issue RRST command to reset the receiver.

Note: Normally D_RSTA register should be read by the microprocessor after a D_RME interrupt. The contents of D_RSTA are valid only after a D_RME interrupt and remain valid until the frame is acknowledged via a RACK bit.

8.7.11 D_ch SAPI Address Mask D_SAM Read/Write Address 0EH

Value after reset: 00H

7	6	5	4	3	2	1	0
SAM7	SAM6	SAM5	SAM4	SAM3	SAM2	SAM1	SAM0

This register masks(disables) the first byte address comparison of the incoming frame. If the mask bit is "1" the corresponding bit comparisons with D_SAP1, D_SAP2 are disabled. Comparison with SAPG is always performed.

Each HDLC frame has two address byte. The first byte is SPAI and second byte is TEI. The D_ch HDLC controller will compare these two bytes with contents of D_SAPI1, DSAP2 and D_TEI1, D_TEI2. If the HDLC frame SAPI matches D_SAPI1 or D_SAP2 and the HDLC frame TEI matches D_TEI1 or D_TEI2, the HDLC frame is captured and stored in D_channel receiving FIFO. If comparison operation is enabled (This means that the more than one bit in D_SAM is set to "1"), except the frame with matching address is stored, others are discarded. If comparison operation is disabled (This means that the all bits in D_SAM are set to "0"), all frame with any address combination are captured and stored in receiving FIFO. The mask operation can be programmed by each bit respectively. **The HDLC frame with SAPG and /or TEIG address are always captured and stored.**

Note: For the LAPD frame, the least significant two bits are the C/R bit and EA = 0 bit. It is suggested that the comparison with C/R bit be masked. EA = 0 for two octet address frame e.g LAPD, EA = 1 for one octet address frame.



8.7.12 D_ch SAPI1 Register D_SAP1 Read/Write Address 0FH

Value after reset: 00H

7	6	5	4	3	2	1	0
SA17	SA16	SA15	SA14	SA13	SA12	SA11	SA10

This register contains the first choice of the first byte address of received frame. For LAPD frame, SA17 - SA12 is the SAPI value, SA11 is C/R bit and SA10 is zero.

8.7.13 D_ch SAPI2 Register D_SAP2 Read/Write Address 10H

Value after reset: 00H

7	6	5	4	3	2	1	0
SA27	SA26	SA25	SA24	SA23	SA22	SA21	SA20

This register contains the second choice of the first byte address of received frame. For LAPD frame, SA27 - SA22 is the SAPI value, SA21 is C/R bit and SA20 is zero.

8.7.14 D_ch TEI Address Mask D_TAM Read/Write Address 11H

Value after reset: 00H

7	6	5	4	3	2	1	0
TAM7	TAM6	TAM5	TAM4	TAM3	TAM2	TAM1	TAM0

This register masks (disables) the second byte address comparison of the incoming frame. If the mask bit is "1" the corresponding bit comparisons with D_TEI1, D_TEI2 are disabled. ***The HDLC frame with SAPG and /or TEIG address are always captured and stored.***

Note: For the LAPD frame, the least significant bit is the EA =1 bit.

8.7.15 D_ch TEI1 Register D_TEI1 Read/Write Address 12H

Value after reset: 00H

7	6	5	4	3	2	1	0
TA17	TA16	TA15	TA14	TA13	TA12	TA11	TA10

TA17 - TA10

This register contains the first choice of the second byte address of received frame. For LAPD frame, TA17 - TA11 is the TEI value, TA10 is EA = 1.



8.7.16 D_ch TEI2 Register D_TEI2Read/Write Address 13H

Value after reset: 00H

7	6	5	4	3	2	1	0
TA27	TA26	TA25	TA24	TA23	TA22	TA21	TA20

TA27 - TA20

This register contains the second choice of the second byte address of received frame. For LAPD frame, TA27 - TA21 is the TEI value, TA20 is EA = 1.

8.7.17 D_ch Receive Frame Byte Count High D_RBCH Read Address 16H

Value after reset: 40H

7	6	5	4	3	2	1	0
VN1	VN0	LOV	RBC12	RBC11	RBC10	RBC9	RBC8

VN1-0 Chip Version Number

This is the chip version number. It is read as 01B.

LOV Length Overflow

A "1" in this bit indicates ≥ 8192 bytes are received and the frame is not yet complete. This bit is valid only after a D_RME interrupt and remains valid until the frame is acknowledge via the RACK command.

RBC12-8 Receive Byte Count

These bits are five most significant bits of the total frame length. These bits are valid only after a D_RME interrupt and remain valid until the frame is acknowledge via the RACK command.

8.7.18 D_ch Receive Frame Byte Count Low D_RBCL Read Address 17H

Value after reset: 00H

7	6	5	4	3	2	1	0
RBC7	RBC6	RBC5	RBC4	RBC3	RBC2	RBC1	RBC0

RBC7-0 Receive Byte Count

These bits are eight least significant bits of the total frame length. Bits RBC4-0 also indicate the length of the data currently available in D_RFIFO. These bits are valid only after an D_RME interrupt and remain valid until the frame is acknowledged via the RACK command.



8.8 GCI Bus Register Description

8.8.1 Channel Selection Register CSEL Read/Write Address 18H

Value after reset: 00H

7	6	5	4	3	2	1	0
0	0	0	0	0	CSEL2	CSEL1	CSEL0

CSEL2, CSEL1 and CSEL0 define W6691 locating in GCI channel number operated in LT-S/ LT-T mode.

8.8.2 Command/Indication Receive Register CIR Read Address 1AH

Value after reset: 0FH

7	6	5	4	3	2	1	0
0	0	0	BAS	CODR3	CODR2	CODR1	CODR0

BAS Bus Access Status Indicate the state of the TIC –bus:

1: W6691 itself occupies the D and C/I channel.

0: Another device occupies the D channel and C/I channel.

CODR3-0 Layer 1 Indication Code

Value of the received layer 1 indication code. Note these bits have a buffer size of two. If TE mode is selected, CODR3-0 bits are CI0 bits in GCI bus channel.

8.8.3 Command/Indication Transmit Register CIX Read/Write Address 1BH

Value after reset: 0FH

7	6	5	4	3	2	1	0
0	0	0	BAC	CODX3	CODX2	CODX1	CODX0

BAC Bus Access Control

It is available if TIC bus function is active. If this bit is set to “1”, W6691 will try to access the TIC-bus to occupy the C/I channel even if no D channel frame has to be transmitted. It should be reset when the access has been completed to grant a similar access to the other devices transmitting in that GCI channel.



CODX3-0 Layer 1 Command Code

Value of the command code is transmitted to layer 1. If TE mode is selected, CODX3-0 bits are CI0 bit in GCI bus channel.

Reading this register returns the previous written value.

8.8.4 S/Q Channel Receive Register SQR Read Address 1CH

Value after reset: XXH

7	6	5	4	3	2	1	0
0	0	MSYN	0	S1	S2	S3	S4

MSYN Multiframe Synchronization

When this bit is "1", a multiframe synchronization is achieved, i.e the S/T receiver has synchronized to the received F_A and M bit patterns.

S1-4 Received S Bits

These are the S bits received in NT to TE direction in frames 1, 6, 11 and 16. S1 is in frame 1, S2 is in frame 6 etc. These four bits are double buffered.

8.8.5 S/Q Channel Transmit Register SQX Read/Write Address 1DH

Value after reset: 0FH

7	6	5	4	3	2	1	0
0	0	0	0	Q1	Q2	Q3	Q4

Q1-4 Transmitted Q Bits

These are the transmitted Q channels in F_A bit positions in frames 1, 6, 11 and 16. Q1 is in frame 1 and Q2 is in frame 6 etc.

Reading this register returns the previous written value.

8.8.6 Monitor Receive Channel 0 MO0R Read Address 20H

Value after reset: FFH

7	6	5	4	3	2	1	0

Contains the Monitor channel data received in GCI Monitor channel 0 according to the Monitor channel protocol.



8.8.7 Monitor Transmit Channel 0 MO0X Read/Write Address 21H

Value after reset: FFH

7	6	5	4	3	2	1	0

Contains the Monitor channel data transmitted in GCI Monitor channel 0 according to the Monitor channel protocol.

8.8.8 Monitor Channel 0 Interrupt Register MO0I Read_clear Address 22H

Value after reset: 00H

7	6	5	4	3	2	1	0
0	0	0	0	MDR0	MER0	MDA0	MAB0

MDR0 Monitor channel 0 Data Receive

MER0 Monitor channel 0 End of Reception

MDA0 Monitor channel 0 Data Acknowledged

The remote end has acknowledged the Monitor byte being transmitted.

MAB0 Monitor channel 0 Data Abort

8.8.9 Monitor Channel 0 Control Register MO0C Read/Write Address 23H

Value after reset: 00H

7	6	5	4	3	2	1	0
0	0	0	0	MRE0	MRC0	MIE0	MXC0

MRE0 Monitor Channel 0 Receive Interrupt Enable

Monitor channel interrupt status MDR0, MER0 generation is enabled (1) or masked (0).

MRC0 "E" Bit Control

Determines the value of the "E" bit:

0: "E" bit always "1". In addition, the MDR0 interrupt is blocked, except for the first byte of a packet (if MRE0 = 1).

1: "E" bit is internally controlled by the W6691 according to Monitor channel protocol.

In addition, the MDR0 interrupt is enabled for all received bytes according to the Monitor channel protocol (if MRE0 = 1).

**MIE0 Monitor channel 0 Transmit Interrupt Enable**

Monitor interrupt status MDA0, MAB0 generation is enabled (1) or masked (0).

MXC0 "A" bit Control

Determines the value of the "A" bit:

0: "A" bit is always 1.

1: "A" bit is internally controlled by W6691 according to Monitor channel protocol.

8.8.10 GCI Mode Control/Status Register GCR Read Address 26H

Value after reset: 00H

7	6	5	4	3	2	1	0
MAC0	MAC1	0	0	0	0	0	0

MAC0 Monitor Transmit Channel 0 Active (Read Only)

Data transmission is in progress in GCI mode Monitor channel 0.

0: the previous transmission has been terminated. Before starting a transmission, the microprocessor should verify that the transmitter is inactive.

1: after having written data into the Monitor Transmit Channel 0 (MO0X) register, the microprocessor sets this bit to 1.

This enables the "A" bit to go active (0), indicating the presence of valid Monitor channel data (contents of MOX) in the corresponding frame.

MAC1 Monitor Transmit Channel 1 Active (Read Only)

Data transmission is in progress in GCI mode Monitor channel 1.

0: the previous transmission has been terminated. Before starting a transmission, the microprocessor should verify that the transmitter is inactive.

1: after having written data into the Monitor Transmit Channel 1 (MO1X) register, the microprocessor sets this bit to 1.

This enables the "A" bit to go active (0), indicating the presence of valid Monitor channel data (contents of MOX) in the corresponding frame.

8.8.11 Monitor Receive Channel 1 Register MO1R Read Address 27H

Value after reset: FFH

7	6	5	4	3	2	1	0

Contains the Monitor channel data received in GCI Monitor channel 1 according to the Monitor channel protocol.

8.8.12 Monitor Transmit Channel 1 Register **MO1X** **Read/Write** **Address 28H**

Value after reset: FFH

7	6	5	4	3	2	1	0

Contains the Monitor channel data transmitted in GCI Monitor channel 1 according to the Monitor channel protocol.

8.8.13 Monitor Channel 1 Interrupt Register **MO1I** **Read_clear** **Address 29H**

Value after reset: 00H

7	6	5	4	3	2	1	0
0	0	0	0	MDR1	MER1	MDA1	MAB1

MDR1 Monitor channel 1 Data Receive

MER1 Monitor channel 1 End of Reception

MDA1 Monitor channel 1 Data Acknowledged

The remote end has acknowledged the Monitor byte being transmitted.

MAB1 Monitor channel 1 Data Abort

8.8.14 Monitor Channel 1 Control Register MO1C **Read/Write** **Address 2AH**

Value after reset: 00H

7	6	5	4	3	2	1	0
0	0	0	0	MRE1	MRC1	MIE1	MXC1

MRE1 Monitor Channel 1 Receive Interrupt Enable

Monitor channel interrupt status MDR1, MER1 generation is enabled (1) or masked (0).

MRC1 “E” Bit Control

Determines the value of the “E” bit:

0: “E” bit is always 1. In addition, the MDR1 interrupt is blocked, except for the first byte of a packet (if MRE1 = 1).

1: “E” bit is internally controlled by the W6691 according to Monitor channel protocol. In addition, the MDR1 interrupt is enabled for all received bytes according to the Monitor channel protocol (if MRE1=1).

**MIE1 Monitor channel 1 Transmit Interrupt Enable**

Monitor interrupt status MDA1, MAB1 generation is enabled (1) or masked (0).

MXC1 “A” bit Control

Determines the value of the “A” bit:

0: “A” bit is always 1.

1: “A” bit internally controlled by the W6691 according to Monitor channel protocol.

8.8.15 GCI CI1 Indication Register CI1R Read Address 31H

Value after reset: Undefined

7	6	5	4	3	2	1	0
0	0	CI1R_6	CI1R_5	CI1R_4	CI1R_3	CI1R_2	CI1R_1

CI1R_6-1

Input data of GCI CI1 channel. CI1R is only used in TE mode selected.

Example application is data of ARCOFI's Peripheral Control Interface input pins.

8.8.16 GCI CI1 Command Register CI1X Read/Write Address 32H

Value after reset: 3FH

7	6	5	4	3	2	1	0
0	0	CI1X_6	CI1X_5	CI1X_4	CI1X_3	CI1X_2	CI1X_1

CI1X6_1

Transmitted data of GCI CI1 channel. CI1R is only used in TE mode selected. A read to these bits returns the previously written value.

Example application is data of ARCOFI's Peripheral Control Interface output pins.

8.8.17 GCI Extended Interrupt Register GCI_EXIR Read_clear Address 34H

Value after reset: 00H

7	6	5	4	3	2	1	0
0	0	0	MO1C	MO0C	0	0	CI1

MO1C Monitor Channel 1 Status Change

A change in the Monitor Channel 1 Interrupt register (MO1I) has occurred. A new Monitor channel byte is stored in the MO1R register.



MO0C Monitor Channel 0 Status Change

A change in the Monitor Channel 0 Interrupt register (MO0I) has occurred. A new Monitor channel byte is stored in the MO0R register.

CI1 CI1 Synchronous Transfer Interrupt

When enabled, an interrupt is generated when there is a change in the received CIR1_6-1 code without double last look criterion. It is only used in TE-mode.

8.8.18 GCI Extended Interrupt Mask Register GCI_EXIM Read/Write Address 35H

Value after reset: F7H

7	6	5	4	3	2	1	0
1	1	1	MO1C	0	0	0	CI1

Bit 7-5 are fixed at "1" and bit 3 is fixed at '0". This means MO0C interrupt cannot be masked. The interrupt is disabled when the bit is set.

8.9 Miscellaneous Register

8.9.1 Timer 1 Register TIMR1 Read/Write Address 38H

Value after reset: 00H

7	6	5	4	3	2	1	0
T1MD	CNT6	CNT5	CNT4	CNT3	CNT2	CNT1	CNT0

T1MD Timer1 Mode

0 = Single Count Down Mode: The timer counts once and generates a T1EXP interrupt when expires.

1 = Periodical Count Down Mode: The timer counts periodically and generates an T1EXP interrupt at each expiration.

CNT6-0 Count Value

The expiration time is defined as:

$$T1 = \text{CNT}[6:0] * 0.1 \text{ second}$$

After writing this register, STT1 bit in D_CMDR register must be set to start the timer. This register can be read only after the timer has been started. The read value indicates the timer's current count value. In case layer 1 is not activated, a C/I command "ECK" must be issued in addition to the STT1 command to start the timer.

Note: The timer is stopped when it expires in Single Count Down Mode(T1MD = 0) or TIMR1 register is re-written in both mode.



8.9.2 Timer 2 TIMR2 Read/ Write Address 39H

Value after reset: 00H

7	6	5	4	3	2	1	0
TMD	TIDLE	TCN5	TCN4	TCN3	TCN2	TCN1	TCN0

TMD Timer 2 Mode

0: Single Count Down mode: The timer starts when it is written a non-zero count value and stops when it reaches zero.

1: Periodical Count Down Mode: The timer starts when it is written a non-zero count value and counts down cyclically (periodically) with the count value.

In both cases, a maskable interrupt TIN2 is generated every time the timer reaches zero. When timer starts, pin TOUT2 changes to HIGH and toggles every half count time. Therefore, the period of TOUT2 equals count value.

In both cases, timer counts with the new value if it is written again before expiration.

The timer is stopped when it expires in single count mode (TMD = 0), or zero count value is written in TCN5-0 (TMD = 0 or 1).

TIDLE TOUT2 Idle

This bit defines value of TOUT2 pin when timer is off. That is to say, the TIDLE determine the TOUT2 pin level is high or low when timer2 is off.

TCN5-0 Timer 2 Count Value

0: Timer is off.

1 - 63: Timer count value in unit of ms.

8.9.3 Peripheral Control Register PCR Read/Write Address 3AH

Value after reset: 00H

7	6	5	4	3	2	1	0
0	0	0	0	OE3	OE2	OE1	OE0

Only for PLCC 68 pins:

OE3 Direction Control for IO3

0: Pin IO3's output driver is disabled and input driver is enabled

1: Pin IO3's output driver is enabled.

Note: The ACLT2: INT1M bit should be set to "0", INT1/IO3 pin can be as IO. Otherwise, It is configured as interrupt input.



OE2 Direction Control for IO2

0: Pin IO2's output driver is disabled and input driver is enabled

1: Pin IO2's output driver is enabled.

Note: The ACLT2: INT0M bit should be set to "0", INT0/IO2 pin can be as IO. Otherwise, It is configured as interrupt input.

OE1 Direction Control for IO1

0: Pin IO1's output driver is disabled and input driver is enabled

1: Pin IO1's output driver is enabled.

OE0 Direction Control for IO0

0 : Pin IO0's output driver is disabled and input driver is enabled

1: Pin IO0's output driver is enabled.

8.9.4 Peripheral I/O Data Register PIODR Read/Write Address 3BH

Value after reset: 00

7	6	5	4	3	2	1	0
0	0	0	0	IO3	IO2	IO1	IO0

Only for PLCC 68 pins:

IO3 Read or Write Data of Pin IO3

On read operation, the present value of pin IO3 is read.

On write operation, the data is driven to pin IO3 only if PCTL:OE3=1.

Note: The ACLT2: INT1M bit should be set to "0", INT1/IO3 pin can be as IO. Otherwise, It is configured as interrupt input.

IO2 Read or Write Data of Pin IO2

On read operation, the present value of pin IO2 is read.

On write operation, the data is driven to pin IO2 only if PCTL:OE2=1.

Note: The ACLT2: INT0M bit should be set to "0", INT0/IO2 pin can be as IO. Otherwise, It is configured as interrupt input.

IO1 Read or Write Data of Pin IO1

On read operation, the present value of pin IO1 is read.

On write operation, the data is driven to pin IO1 only if PCTL:OE1=1.

IO0 Read or Write Data of Pin IO0

On read operation, the present value of pin IO0 is read.

On write operation, the data is driven to pin IO0 only if PCTL:OE0=1.



8.9.5 SFCTL Switch Functional Control Register Read/Write Address 3CH

Value after reset: 00H

7	6	5	4	3	2	1	0
0	PGSWH	PCRLP	PXC	B2SW1	B2SW0	B1SW1	B1SW0

PGSWH PCM and GCI bus Switch

Determines the CODEC interface is to be operated in B channel.

1: PCM bus is selected to operate with CODEC.

0: GCI bus is selected to operate with CODEC.

PCRLP PCM Remote Loop Back

Setting this bit activates the PCM channel remote loopback function. The transmitted PCM data to PCM channel are looped to received PCM channel.

PXC PCM Cross-connect

This bit determines whether or not the PCM ports are cross-connected with the B channel ports. The setting of PXC is independent of the BSW1-0 bits.

PXC	Connection
0	PCM1 ↔ B1, PCM2 ↔ B2
1	PCM1 ↔ B2, PCM2 ↔ B1

B2SW1/B2SW0 B2 channel Switch

These two bits determine B2 channel switch among PCM port, GCI and Layer2.

00: Select B2 channel switch between Layer2 and Layer1/GCI.

01: Select B2 channel switch between Layer1/GCI and PCM.

10: Select B2 channel switch between PCM and Layer2.

B1SW1 / B1SW0 B1 channel Switch

These two bits determine B1 channel switch among PCM port, GCI and Layer2.

00: Select B1 channel switch between Layer2 and Layer1/GCI.

01: Select B1 channel switch between Layer1/GCI and PCM.

10: Select B1 channel switch between PCM and Layer2.



8.9.6 ACTL1 Auxiliary Control Register 1 Read/Write Address 3DH

Value after reset: 00H

7	6	5	4	3	2	1	0
0	0	SRST	0	0	0	OPS1	OPS0

SRST Software Reset

When this bit is set to "1" 1ms at least, a software reset signal is activated. The effect of the reset signal is same as the hardware reset.

This bit is not auto-clear, the software must write "0" to this bit to exit from the reset mode.

Note: When SRST = 1, the chip is in reset state. Read or write to any of the registers is inhibited at this moment.

OPS1-0 Output Phase Delay Compensation Select1-0

These two bits select the output phase delay compensation.

OPS1	OPS0	EFFECT
0	0	No output phase delay compensation
0	1	Output phase delay compensation 260nS
1	0	Output phase delay compensation 520 nS
1	1	Output phase delay compensation 1040 nS

8.9.7 ACTL2 Auxiliary Control Register2 Read/Write Address 3EH

Value after reset: 40H

7	6	5	4	3	2	1	0
0	ACTL1S	LC	0	SPU	0	0	0

ACTL1S Activate Layer1 Status

0: When Layer 1 operates in activate state, ACTL1S pin is pulled to low level. In contrast, if Layer 1 operates in deactivate state, ACTL1S pin is driven to high level.

1: The ACTL1 output level is programmed by microprocessor.(ACTL2 : ACTL1S)

LC LED Controlled

If ACTL1S is set to "1", LC bit is programmable by microprocessor.

0: It shows ACTL1S pin is driven to high level.

1: It shows ACTL1S pin is driven to low level.

SPU: Software Power UP

If SPU is set to "1", W6691 can awaked from power down mode.



8.9.8 ACTL3 Auxiliary Control Register 3 Read/Write Address 3FH

Value after reset: 00H

7	6	5	4	3	2	1	0
0	INTOL	0	0	0	0	0	0

INTOL Interrupt Output Level Configuration

0: It shows INT pin is low active (open drain).

1: It shows INT pin is high active.

8.10 B1 Channel HDLC Controller Register Address MAP

TABLE 8.7 B1 CHANNEL HDLC CONTROLLER REGISTER ADDRESS MAP

Offset	Access	Register Name	Description
50	R	B1_RFIFO	B1 channel receive FIFO
51	W	B1_XFIFO	B1 channel transmit FIFO
52			Reserved
53	R/W	B1_CMDR	B1 channel command register
54	R/W	B1_MODE	B1 channel mode control
55			Reserved
56	R_clear	B1_EXIR	B1 channel extended interrupt
57	R/W	B1_EXIM	B1 channel extended interrupt mask
58	R	B1_STAR	B1 channel status register
59	R/W	B1_ADM1	B1 channel address mask 1
5A	R/W	B1_ADM2	B1 channel address mask 2
5B	R/W	B1_ADR1	B1 channel address 1
5C	R/W	B1_ADR2	B1 channel address 2
5D	R	B1_RBCL	B1 channel receive frame byte count low
5E	R	B1_RBCH	B1 channel receive frame byte count high
5F	R/W	B1_IDLE	B1 channel transmit idle pattern



8.11 B1 Channel HDLC Controller Register Memory Map

TABLE 8.8 B1 CHANNEL HDLC CONTROLLER REGISTER MEMORY MAP

Offset	R/W	Name	7	6	5	4	3	2	1	0
50	R	B1_RFIFO								
51	W	B1_XFIFO								
52			Reserved							
53	R/W	B1_CMDR	RACK	RRST	0	0	0	XMS	XME	XRST
54	R/W	B1_MODE	MMS	ITF	RACT	XACT	B1_128	SW56	FTS1	FTS0
55			Reserved							
56	R_clr	B1_EXIR	0	RMR	RME	RDOV	0	0	XFR	XDUN
57	R/W	B1_EXIM	1	RMR	RME	RDOV	1	1	XFR	XDUN
58	R	B1_STAR	0	RDOV	CRCE	RMB	0	XDOW	0	XBZ
59	R/W	B1_ADM1	MA17	MA16	MA15	MA14	MA13	MA12	MA11	MA10
5A	R/W	B1_ADM2	MA27	MA26	MA25	MA24	MA23	MA22	MA21	MA20
5B	R/W	B1_ADR1	RA17	RA16	RA15	RA14	RA13	RA12	RA11	RA10
5C	R/W	B1_ADR2	RA27	RA26	RA25	RA24	RA23	RA22	RA21	RA20
5D	R	B1_RBCL	RBC7	RBC6	RBC5	RBC4	RBC3	RBC2	RBC1	RBC0
5E	R	B1_RBCH	0	0	LOV	RBC12	RBC11	RBC10	RBC9	RBC8
5F	R/W	B1_IDLE	IDLE7	IDLE6	IDLE5	IDLE4	IDLE3	IDLE2	IDLE1	IDLE0

8.11.1 B1_ch receive FIFO B1_RFIFO Read Address 50H

The B1_RFIFO is a 128-byte depth FIFO memory with programmable threshold. The threshold value determines when to generate an interrupt.

When more than a threshold length of data has been received, a RMR interrupt is generated. After an RMR interrupt, 64 or 96 bytes can be read out, depending on the threshold setting.

In transparent mode, when the end of frame has been received, a RME interrupt is generated. After an RME interrupt, the number of bytes available is less than or equal to the threshold value.

8.11.2 B1_ch transmit FIFO B1_XFIFO Write Address 51H

The B1_XFIFO is a 128-byte depth FIFO with programmable threshold value. The threshold setting is the same as B1_RFIFO.

When the number of empty locations is equal to or greater than the threshold value, a XFR interrupt is generated. After a XFR interrupt, up to 64 or 96 bytes of data can be written into this FIFO for transmission.



8.11.3 B1_ch command register B1_CMDR Read/Write Address 53H

Value after reset: 00H

7	6	5	4	3	2	1	0
RACK	RRST	0	0	0	XMS	XME	XRST

RACK Receive Message Acknowledge

After a RMR or RME interrupt, the microprocessor reads out the data in B1_RFIFO, it then sets this bit to explicitly acknowledge the interrupt.

This bit is write only. It's auto-clear. Writing "0" to this bit has no effect. If RACK bit is set to "1" for operating "Receiver Acknowledge", It is not necessary to reset RACK bit to "0" by host processor. That is to say, once RACK is set to "1", RACK bit is reset to "0" by W6691 automatically.

RRST Receiver Reset

Setting this bit resets the B1_ch HDLC receiver.

This bit is write-only. It's auto-clear. Writing "0" to this bit has no effect. If RRST bit is set to "1" for operating "Receiver Reset", It is not necessary to reset RRST bit to "0" by host processor. That is to say, once RRST is set to "1", RRST bit is reset to "0" by W6691 automatically.

XMS Transmit Message Start/Continue

In transparent mode, setting this bit initiates the transparent transmission of B1_XFIFO data. The opening flag is automatically added to the message by the B1_ch HDLC controller. Zero bit insertion is performed on the data. This bit is also used in subsequent transmission of the frame.

In extended transparent mode, setting this bit activates the transmission of B1_XFIFO data. No flag, CRC or zero bit insertion is added on the data.

This bit is write-only. It's auto-clear. Writing "0" to this bit has no effect. If XMS bit is set to "1" for operating "Transmit Message Start/Continue", It is not necessary to reset XMS bit to "0" by host processor. That is to say, once XMS is set to "1", XMS bit is reset to "0" by W6691 automatically.

XME Transmit Message End

In transparent mode, setting this bit indicates the end of the whole frame transmission. The B1_ch HDLC controller transmits the data in FIFO and automatically appends the CRC and the closing flag sequence in transparent mode.

In extended transparent mode, setting this bit stops the B1_XFIFO data transmission.

This bit is write-only. It's auto-clear.



XRST Transmitter Reset

Setting this bit resets the B1_ch HDLC transmitter and clears the B1_XFIFO. The transmitter will send inter frame time fill pattern on B channel in transparent mode, or idle pattern in extended transparent mode. This command also results in a transmit FIFO ready condition.

This bit is write only. It's auto-clear.

8.11.4 B1_ch Mode Register B1_MODE Read/Write Address 54H

Value after reset: 00H

7	6	5	4	3	2	1	0
MMS	ITF	RACT	XACT	B1_128K	SW56	FTS1	FTS0

MMS Message Mode Setting

Determines the message transfer modes of the B1_ch HDLC controller:

0: Transparent mode. In received direction, address comparison is performed on each frame. The frames with matched address are stored in B1_RFIFO. Flag deletion, CRC check and zero bit deletion are performed. In transmitted direction, the data is transmitted with flag insertion, zero bit insertion and CRC generation.

1: Extended transparent mode. In received direction, all data are received and stored in the B1_RFIFO. In transmitted direction, all data in the B1_XFIFO are transmitted without alteration.

ITF Inter-frame Time Fill

Defines the inter-frame time fill pattern in transparent mode.

0: Mark. The binary value "1" is transmitted.

1: Flag. This is a sequence of "01111110".

RACT Receiver Active

"1": transmitter is active, 64 KHz clock is provided.

"0": transmitter is inactive, clock is LOW to save power.

This bit is read/write. Read operation returns the previously written value.

Note: The receiver is deactive after hardware reset or software reset.

XACT Transmitter Active

"0": transmitter is active, 64 KHz clock is provided.

"1": transmitter is inactive, clock is LOW to save power.

This bit is read/write. Read operation returns the previously written value.

Note: The transmitter is deactive after hardware reset or software reset.

**B1_128 128K Mode**

"1": Both B1 and B2 channels in layer 1 are combined into single layer 2 channel. The layer 2 B1 channel can operate in transparent mode or extended transparent mode and layer 2 B2 channel is not used.

"0": Both B1 and B2 channels in layer 1 are not combined.

This bit is read/write. Read operation returns the previously written value.

SW56 Switch 56 Traffic

0: The data rate in B1 channel is 64 Kbps.

1: The data rate in B1 channel is 56 Kbps. The most significant bit in each octet is fixed at "1".

Note: In 56 Kbps mode, only transparent mode can be used.

FTS1-0 FIFO Threshold Select

These two bits determine the B1 channel receive and transmit FIFO's threshold setting. An interrupt is generated when the number of received data or the number of vacancies in XFIFO reaches the threshold value.

FTS1	FTS0	Threshold (byte)
0	0	64
0	1	Reserved
1	0	96
1	1	Not allowed

8.11.5 B1_ch Extended Interrupt Register B1_EXIR Read_clear Address 56H

Value after reset: 00H

7	6	5	4	3	2	1	0
0	RMR	RME	RDOV	0	0	XFR	XDUN

RMR Receive Message Ready

At least a threshold length of data has been stored in the B1_RFIFO.

RME Receive Message End

Used in transparent mode only. The last block of a frame has been received. The frame length can be found in B1_RBCH + B1_RBCL registers. The number of data available in the B1_RFIFO equals frame length modulus threshold. The result of CRC check is indicated by B1_STAR: CRCE bit.

When the number of last block of a frame equals the threshold, only RME interrupt is generated.



RDOV Receive Data Overflow

Data overflow occurs in the receive FIFO. The incoming data will overwrite the data in the receive FIFO.

XFR Transmit FIFO Ready

This interrupt indicates that up to a threshold length of data can be written into the B1_XFIFO.

XDUN Transmit Data Underrun

This interrupt occurs when the B1_XFIFO has run out of data. In this case, the W6691 will automatically reset the transmitter and send the inter frame time fill pattern on B channel. The software must wait until transmit FIFO ready condition (via XFR interrupt), re-write data, and issue XMS command to re-transmit the data.

8.11.6 B1_ch Extended Interrupt Mask Register B1_EXIM Read/Write Address 57H

Value after reset: FFH

7	6	5	4	3	2	1	0
1	RMR	RME	RDOV	1	1	XFR	XDUN

Setting the bit to "1" masks the corresponding interrupt source in B1_EXIR register. Masked interrupt status bits are read as zero when B1_EXIR register is read. They are internally stored and pending until the mask bits are zero.

All the interrupts in B1_EXIR will be masked if the IMASK: B1_EXI bit is set to "1".

8.11.7 B1_ch Status Register B1_STAR Read Address 58H

Value after reset: 20H

7	6	5	4	3	2	1	0
0	RDOV	CRCE	RMB	0	XDOW	0	XBZ

RDOV Receive Data Overflow

A "1" indicates that the D_RFIFO is overflow. The incoming data will overwrite data in the receive FIFO. The overflow condition will set both the status and interrupt bits. It is recommended that software must read the RDOV bit after reading data from receive FIFO at RMR or RME interrupt. The software must abort the data and issue a RRST command to reset the receiver if RDOV = 1.

CRCE CRC Error

Used in transparent mode only. This bit indicates the result of frame CRC check:

0: CRC correct

1: CRC incorrect



RMB Receive Message Aborted

Used in transparent mode only. A "1" means that a sequence of \geq seven 1's was received and the frame is aborted by the B1_HDLC controller. Software must issue RRST command to reset the receiver.

Note: Bit CRCE is valid only after a RME interrupt and remains valid until the frame is acknowledged via RACK command. RMB must be polled after a RMR/RME interrupt.

XDOW Transmit Data Overwritten

At least one byte of data has been overwritten in the B1_XFIFO. This bit is cleared only by XRST command.

XBZ Transmitter Busy

The B1_HDLC transmitter is busy when XBZ is read as "1". This bit may be polled. The XBZ bit is active when an XMS command was issued and the message has not been completely transmitted.

8.11.8 B1_ch Address Mask Register 1 B1_ADM1 Read/Write Address 59H

Value after reset: 00H

7	6	5	4	3	2	1	0
MA17	MA16	MA15	MA14	MA13	MA12	MA11	MA10

MA17-10 Address Mask Bits

Used in transparent mode only. These bits mask the first byte address comparisons. If the mask bit is "1", the corresponding bit comparison with B1_ADR1 is disabled.

0: Unmask comparison

1: Mask comparison

8.11.9 B1_ch Address Mask Register 2 B1_ADM2 Read/Write Address 5AH

Value after reset: 00H

7	6	5	4	3	2	1	0
MA27	MA26	MA25	MA24	MA23	MA22	MA21	MA20

MA27-20 Address Mask Bits

Used in transparent mode only. These bits mask the second byte address comparisons. If the mask bit is "1", the corresponding bit comparison with B1_ADR2 is disabled.

0: Unmask comparison

1: Mask comparison



8.11.10 B1_ch Address Register 1 B1_ADR1 Read/Write Address 5BH

Value after reset: 00H

7	6	5	4	3	2	1	0
RA17	RA16	RA15	RA14	RA13	RA12	RA11	RA10

RA17-10 Address Bits

Used in transparent mode only. These bits are used for the first byte address comparisons.

8.11.11 B1_ch Address Register 2 B1_ADR2 Read/Write Address 5CH

Value after reset: 00H

7	6	5	4	3	2	1	0
RA27	RA26	RA25	RA24	RA23	RA22	RA21	RA20

RA27-20 Address Bits

Used in transparent mode only. These bits are used for the second byte address comparisons.

8.11.12 B1_ch Receive Frame Byte Count Low B1_RBCL Read Address 5DH

Value after reset: 00H

7	6	5	4	3	2	1	0
RBC7	RBC6	RBC5	RBC4	RBC3	RBC2	RBC1	RBC0

RBC7-0 Receive Byte Count

Used in transparent mode only. Eight least significant bits of the total number of bytes are in a received frame. These bits are valid only after a RME interrupt and remain valid until the frame is acknowledge via the RACK bit.

8.11.13 B1_ch Receive Frame Byte Count High B1_RBCH Read Address 5EH

Value after reset: 00H

7	6	5	4	3	2	1	0
0	0	LOV	RBC12	RBC11	RBC10	RBC9	RBC8

LOV Message Length Overflow

Used in transparent mode only. A "1" in this bit indicates a received message ≥ 8192 bytes. This bit is valid only after RME interrupt and is cleared by the RACK command.



RBC12-8 Receive Byte Count

Used in transparent mode only. Five most significant bits of the total number of bytes are in a received frame. These bits are valid only after a RME interrupt and remain valid until the frame is acknowledge via the RACK bit.

Note: The frame length equals RBC12-0. This length is between 1 and 8191. After a RME interrupt, the number of data available in B1_RFIFO is frame length modulus threshold.

Remainder = RBC12-0 MOD threshold

No of available data = remainder if remainder \neq 0 or

No of available data = threshold if remainder = 0

The remainder equals RBC5-0 if threshold is 64.

8.11.14 B1_ch Transmit Idle Pattern B1_IDLE Read/Write Address 5FH

Value after reset: FFH

7	6	5	4	3	2	1	0
IDLE7	IDLE6	IDLE5	IDLE4	IDLE3	IDLE2	IDLE1	IDLE0

IDLE7-0

This pattern is transmitted when the transmitter is active and transmit FIFO is empty. Valid in extended transparent mode only.



8.12 B2 Channel HDLC Controller Register Address Map

TABLE 8.9 B2 CHANNEL HDLC CONTROLLER REGISTER ADDRESS MAP

Offset	Access	Register Name	Description
70	R	B2_RFIFO	B2channel receive FIFO
71	W	B2_XFIFO	B2 channel transmit FIFO
72			Reserved
73	R/W	B2_CMDR	B2 channel command register
74	R/W	B2_MODE	B2 channel mode control
75			Reserved
76	R_clear	B2_EXIR	B2 channel extended interrupt
77	R/W	B2_EXIM	B2 channel extended interrupt mask
78	R	B2_STAR	B2 channel status register
79	R/W	B2_ADM1	B2 channel address mask 1
7A	R/W	B2_ADM2	B2 channel address mask 2
7B	R/W	B2_ADR1	B2 channel address 1
7C	R/W	B2_ADR2	B2 channel address 2
7D	R	B2_RBCL	B2 channel receive frame byte count low
7E	R	B2_RBCH	<i>B2 channel receive frame byte count high</i>
7F	R/W	B2_IDLE	<i>B2 channel transmit idle pattern</i>



8.13 B2 Channel HDLC Controller Register Memory Map

TABLE 8.10 B2 CHANNEL HDLC CONTROLLER REGISTER MEMORY MAP

Offset	R/W	Name	7	6	5	4	3	2	1	0
70	R	B2_RFIFO								
71	W	B2_XFIFO								
72			Reserved							
73	R/W	B2_CMDR	RACK	RRST	0	0	0	XMS	XME	XRST
74	R/W	B2_MODE	MMS	ITF	RACT	XACT	0	SW56	FTS1	FTS0
75			Reserved							
76	R_clr	B2_EXIR	0	RMR	RME	RDOV	0	0	XFR	XDUN
77	R/W	B2_EXIM	1	RMR	RME	RDOV	1	1	XFR	XDUN
78	R	B2_STAR	0	RDOV	CRCE	RMB	0	XDOW	0	XBZ
79	R/W	B2_ADM1	MA17	MA16	MA15	MA14	MA13	MA12	MA11	MA10
7A	R/W	B2_ADM2	MA27	MA26	MA25	MA24	MA23	MA22	MA21	MA20
7B	R/W	B2_ADR1	RA17	RA16	RA15	RA14	RA13	RA12	RA11	RA10
7C	R/W	B2_ADR2	RA27	RA26	RA25	RA24	RA23	RA22	RA21	RA20
7D	R	B2_RBCL	RBC7	RBC6	RBC5	RBC4	RBC3	RBC2	RBC1	RBC0
7E	R	B2_RBCH	0	0	LOV	RBC12	RBC11	RBC10	RBC9	RBC8
7F	R/W	B2_IDLE	IDLE7	IDLE6	IDLE5	IDLE4	IDLE3	IDLE2	IDLE1	IDLE0

The B2 channel HDLC controller register's definitions and functions are the same as those of B1 channel HDLC. Please refer to B1 channel section for a detailed description.



9. ELECTRICAL CHARACTERISTICS

9.1 Absolute Maximum Rating

PARAMETER	SYMBOL	LIMIT VALUES	UNIT
Voltage on any pin with respect to ground	V_S	-0.4 to $V_{DD} + 0.4$	V
Ambient temperature under bias	T_A	0 to 70	°C
Maximum voltage on V_{DD}	V_{DD}	6	V

9.2 Power Supply

The power supply is 3.3V \pm 5%.

9.3 DC Characteristics

$T_A = 0$ to 70°C; $V_{DD} = 3.3$ V \pm 5%, $V_{SSA} = 0$ V, $V_{SSD} = 0$ V

PARAMETER	SYM.	MIN.	MAX.	UNIT	TEST CONDITIONS	REMARKS
Low Input Voltage	V_{IL}	-0.4	0.8	V		
High Input Voltage	V_{IH}	2.0	$V_{DD} + 0.4$	V		
Low Output Voltage	V_{OL}		0.4	V	$I_{OL} = 12$ mA	
High Output Voltage	V_{OH}	2.4		V		
Analog Power Supply Current: Power Down	I_{CC}		1.5	mA	$V_{DDA} = 5$ V (internal power supply), S/T layer 1 in state "F3 Deactivated without clock"	
Analog Power Supply Current: Activated	I_{CC}		6.5	mA	$V_{DD} = 3.3$ V, S/T layer 1 in state "F7 Activated"	
Input Leakage Current	I_{LI}		10	μ A	0 V < V_{IN} < V_{DD} to 0V	All pins except SX1, 2, SR1, 2
Output Leakage Current	I_{LO}		10	μ A	0 V < V_{OUT} < V_{DD} to 0V	All pins except SX1, 2, SR1, 2
Absolute Value of Output Pulse Amplitude ($V_{SX2} - V_{SX1}$)	V_X	2.03	2.31	V	$R_L = 50 \Omega$ ¹⁾	SX1, 2
		2.10	2.39	V	$R_L = 400 \Omega$ ¹⁾	
Transmitter Output Current	I_X	7.5	13.4	mA	$R_L = 5.6 \Omega$ ¹⁾	SX1, 2
Transmitter Output Impedance	R_X	30		k Ω	Inactive or during binary ONE	SX1, 2
		23		Ω	During binary ZERO ($R_L = 50 \Omega$)	

Note: ¹⁾ Due to the transformer, the load resistance seen by the circuit is four times R_L .



Capacitances

$T_A = 25^\circ\text{C}$, $V_{DD} = 3.3\text{V} \pm 5\%$, $V_{SSA} = 0\text{V}$, $V_{SSD} = 0\text{V}$, $f_c = 1\text{ Mhz}$, unmeasured pins grounded.

PARAMETER	SYMBOL	MIN.	MAX.	UNIT	REMARKS
Input capacitance	C_{IN}		7	pF	All pins except SR1, 2
I/O pin capacitance	C_{IO}		7	pF	All pins except SR1, 2
Output capacitance against V_{SSA}	C_{OUT}		10	pF	SX1, 2
Input capacitance	C_{IN}		7	pF	SR1, 2
Load capacitance	C_L		50	pF	XTAL1, 2

Recommended oscillator circuits

Crystal specifications

PARAMETER	SYMBOL	VALUES	UNIT
Frequency	F	7.680	MHz
Frequency Calibration Tolerance		Max. 100	ppm
Load Capacitance	C_L	Max. 50	pF
Oscillator Mode		Fundamental	

Note: The load capacitance C_L depends on the crystal specification. The typical values are 33 to 47 pF.

External oscillator input (XTAL1) clock characteristics

PARAMETER	MIN.	MAX.
Duty cycle	1:2	2:1

9.4 Preliminary Switching Characteristics

9.4.1 PCM Interface Timing

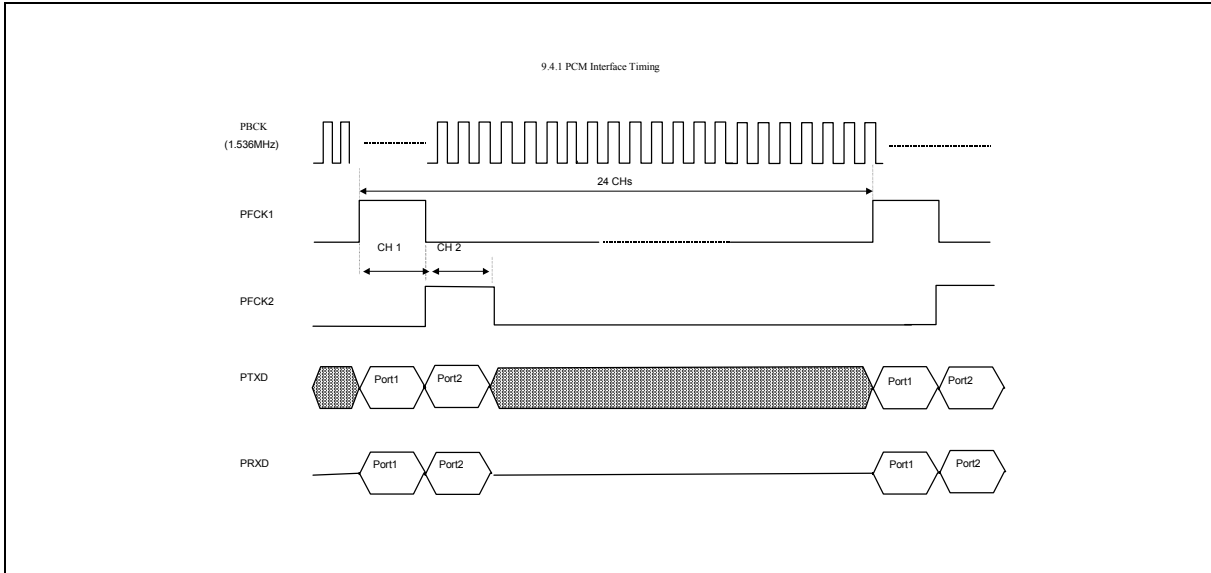

Notes:

1. These drawings are not to scale.
2. The frequency of PBCK is 1536 KHz which includes 24 channels of 64 kbps data. The PFCK1 and PFCK2 are located at channel 1 and channel 2, each with a 8 x PBCK duration.

9.4.2 Detailed PCM Tming

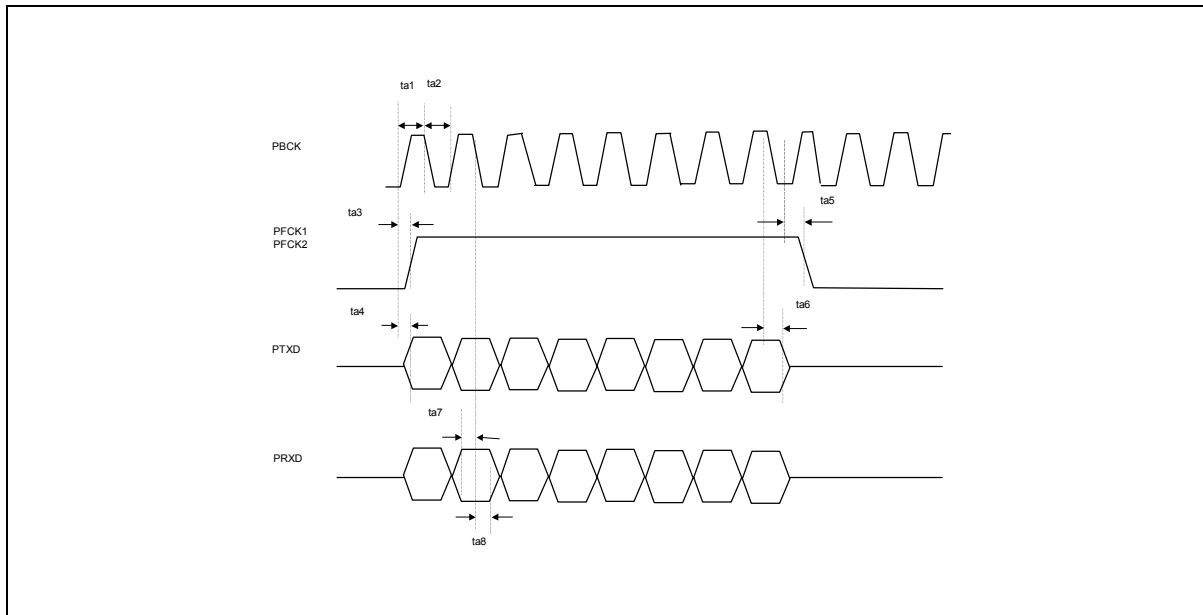

PARAMETER	PARAMETER DESCRIPTIONS	MIN.	NOMINAL	MAX.	REMARKS
ta1	PBCK pulse high		325		Unit = nS
ta2	PBCK pulse low	195	325	455	
ta3	Frame clock asserted from PBCK			20	
ta4	PTXD data delay from PBCK			20	
ta5	Frame clock deasserted from PBCK			20	
ta6	PTXD hold time from PBCK	10			
ta7	PRXD setup time to PBCK	20			
ta8	PRXD hold time from PBCK	10			

Note:

The PCM clocks are locked to the S/T receive clock. At every two or three PCM frame time (125 μ S), PBCK and PFCK1, PFCK2 may be adjusted by one local oscillator cycle (130 nS) in order to synchronize with S/T clock. This shift is made on the LOW level time of PBCK and the HIGH level time is not affected. This introduces jitters on the PBCK, PFCK1 and PFCK2 with jitter amplitude 260 ns (peak-to-peak) and jitter frequency about 2.67~4 KHz.

9.4.3 8-bit Microprocessor Timing

Intel Mode Read Cycle Timing

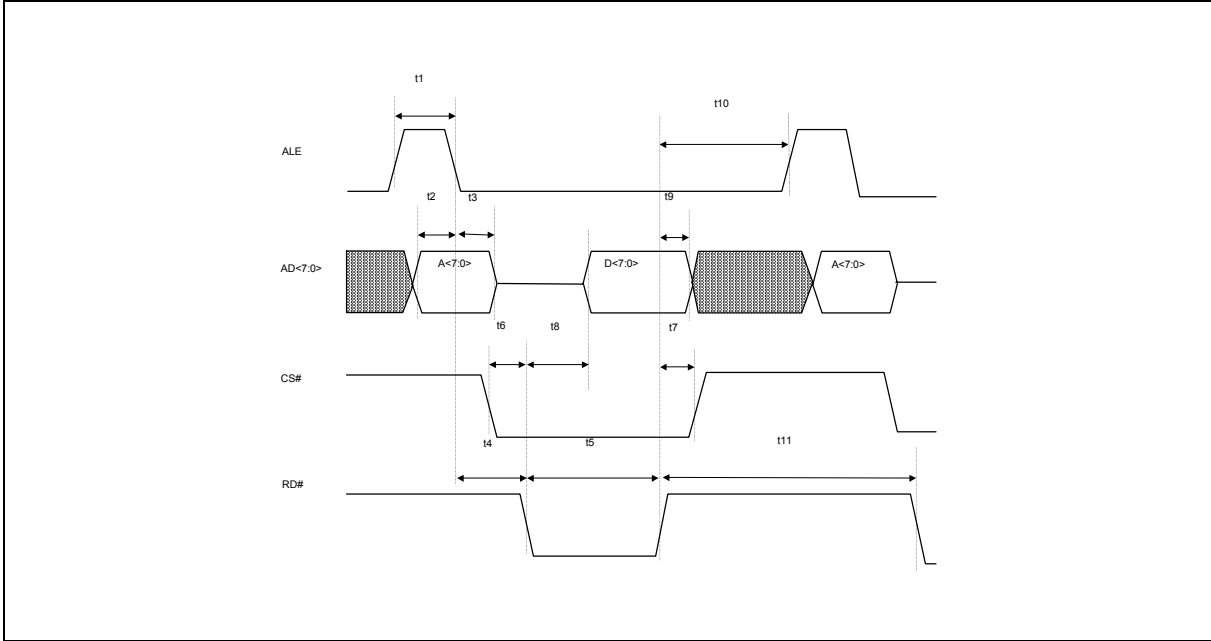

Intel Mode Write Cycle Timing

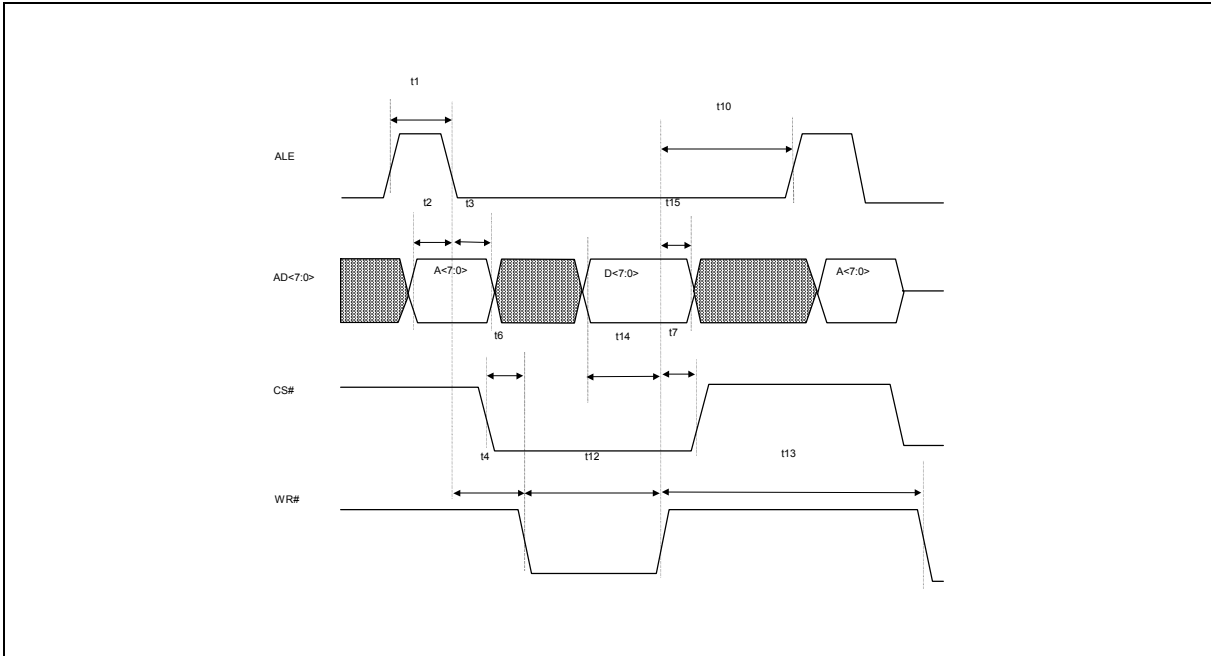

Motorola Mode Read Cycle Timing

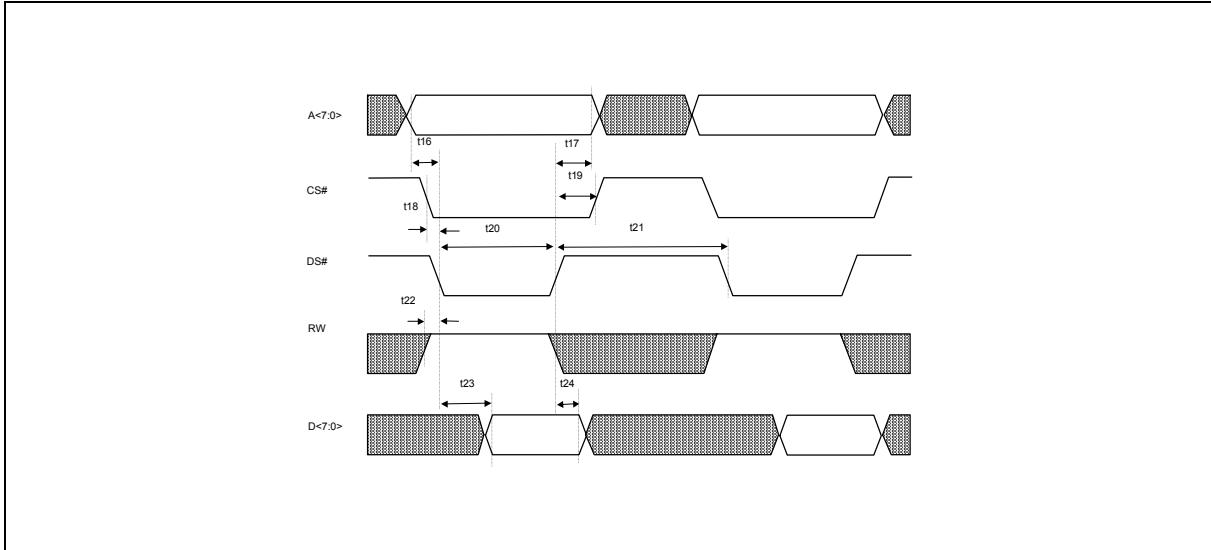

Motorola Mode Write Cycle Timing

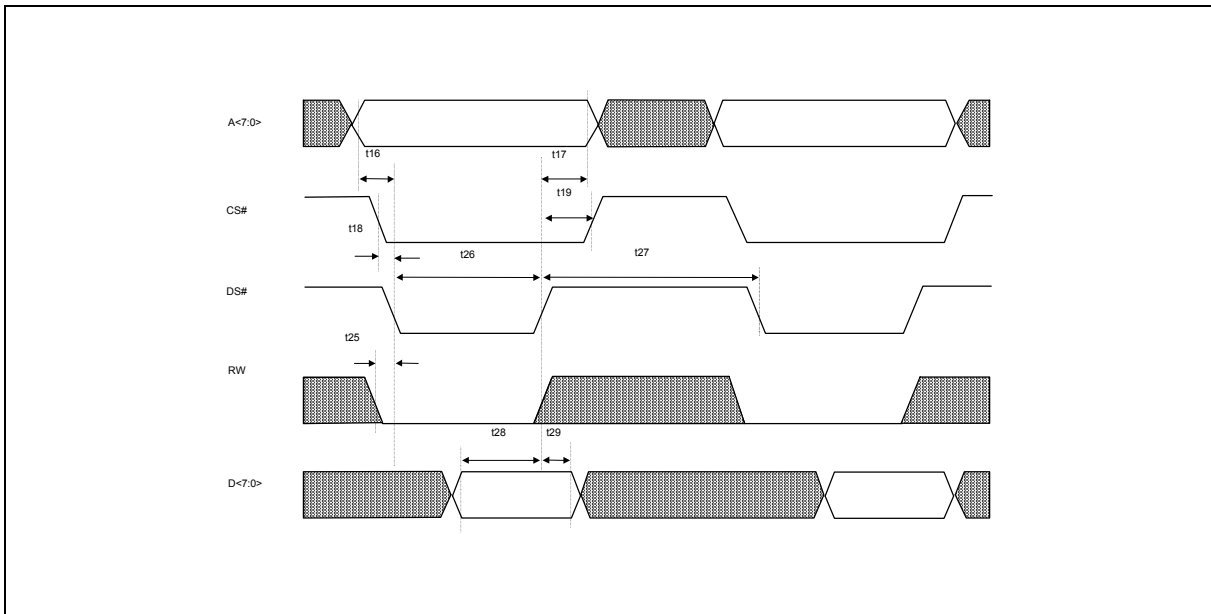

PARAMETER	PARAMETER DESCRIPTIONS	MIN.	MAX.	REMARKS
t1	ALE pulse width	50		
t2	Address setup time to ALE	15		
t3	Address hold time from ALE	10		
t4	Address setup time to RD#, WR#	0		
t5	RD# pulse width	110		
t6	CS# setup time to RD#, WR#	0		
t7	CS# hold time from RD#, WR#	0		
t8	Data output delay from RD#		50	
t9	Data float from RD#		25	
t10	ALE guard time	15		
t11	RD# recovery time	70		
t12	WR# pulse width	60		
t13	WR# recovery time	70		
t14	Data setup time to WR#	35		
t15	Data hold time from WR#	10		
t16	Address setup time to DS#	25		
t17	Address hold time from DS#	10		
t18	CS# setup time to DS#	10		
t19	CS# hold time from DS#	10		
t20	DS# read pulse width	110		
t21	DS# read recovery time	70		
t22	RW setup time to DS# read	0		
t23	Data output delay from DS#		110	
t24	Data hold time from DS#		25	
t25	RW setup time to DS# write	0		
t26	DS# write pulse width	60		
t27	DS# write recovery time	70		
t28	Write data setup time to DS#	35		
t29	Write data hold time from DS#	10		



9.5 AC Timing Test Conditions

$T_A = 0$ to 70°C , $V_{DD} = 3.3\text{V} \pm 5\%$

Inputs are driven to 2.4 V for logical 1 and 0.4 V for logical 0. Measurements are made at 2.0 V for logical 1 and 0.8 V for logical 0. The AC testing input/output waveforms are shown below:

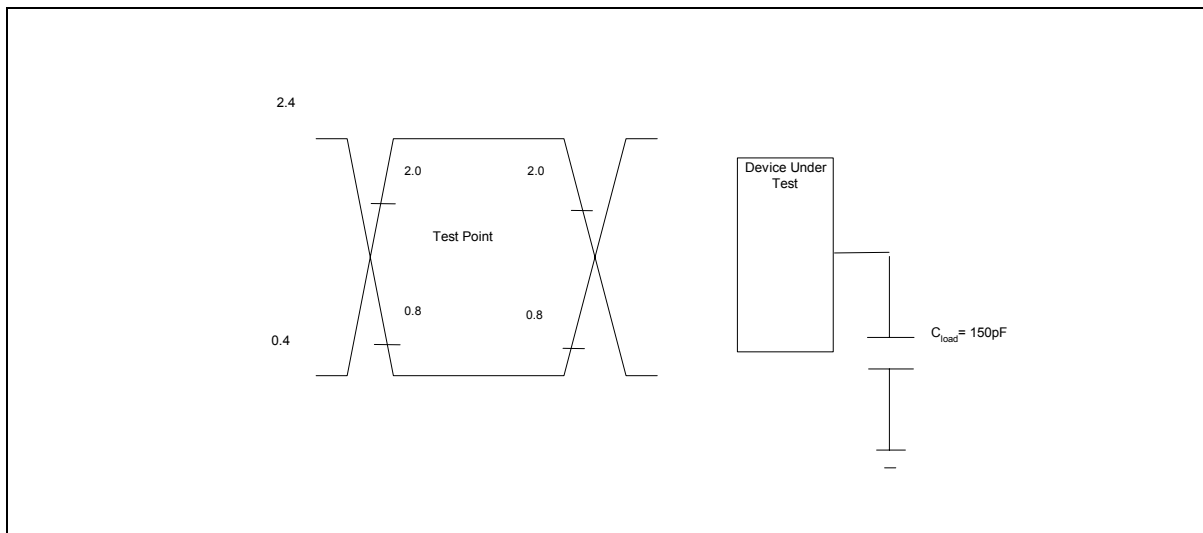

10. ORDERING INFORMATION

PART NUMBER	PACKAGE TYPE	PRODUCTION FLOW
W6691	64-pin LQFP	Commercial, 0°C to $+70^\circ\text{C}$

11. PACKAGE DIMENSIONS

64L LQFP (10 x 10 x 1.4 mm)

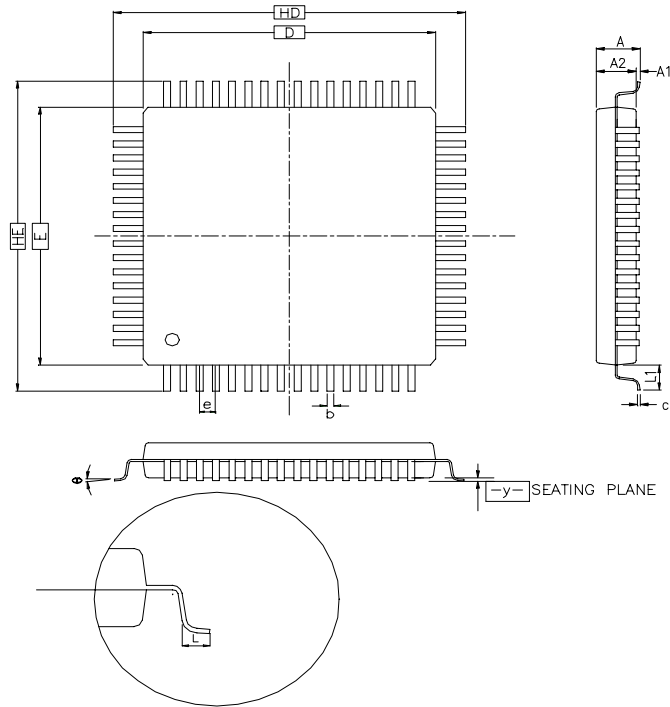

Symbol	Dimension in inch			Dimension in mm		
	Min.	Nom.	Max.	Min.	Nom.	Max.
A	—	—	0.063	—	—	1.60
A₁	0.002	—	0.006	0.05	—	0.15
A₂	0.053	0.055	0.057	1.35	1.40	1.45
b	0.007	0.008	0.011	0.17	0.20	0.27
c	0.004	—	0.008	0.09	—	0.20
D	—	0.393	—	—	10.00	—
E	—	0.393	—	—	10.00	—
e	—	0.020	—	—	0.50	—
H_D	—	0.472	—	—	12.00	—
H_E	—	0.472	—	—	12.00	—
L	0.018	0.024	0.030	0.45	0.60	0.75
L₁	—	0.039	—	—	1.00	—
y	—	0.003	—	—	0.08	—
θ	0°	3.5°	7°	0°	3.5°	7°



Headquarters
No. 4, Creation Rd. III,
Science-Based Industrial Park,
Hsinchu, Taiwan
TEL: 886-3-5770066
FAX: 886-3-5665577
<http://www.winbond.com.tw/>

Taipei Office
9F, No.480, Rueiguang Rd.,
Neihu District, Taipei, 114,
Taiwan, R.O.C.
TEL: 886-2-8177-7168
FAX: 886-2-8751-3579

Winbond Electronics Corporation America
2727 North First Street, San Jose,
CA 95134, U.S.A.
TEL: 1-408-9436666
FAX: 1-408-5441798

Winbond Electronics Corporation Japan
7F Daini-ueno BLDG, 3-7-18
Shinyokohama Kohoku-ku,
Yokohama, 222-0033
TEL: 81-45-4781881
FAX: 81-45-4781800

Winbond Electronics (Shanghai) Ltd.
27F, 2299 Yan An W. Rd. Shanghai,
200336 China
TEL: 86-21-62365999
FAX: 86-21-62365998

Winbond Electronics (H.K.) Ltd.
Unit 9-15, 22F, Millennium City,
No. 378 Kwun Tong Rd.,
Kowloon, Hong Kong
TEL: 852-27513100
FAX: 852-27552064

*Please note that all data and specifications are subject to change without notice.
All the trade marks of products and companies mentioned in this data sheet belong to their respective owners.*