

Features

- Yellow colored diffusion transparency lens type
- $\phi 3\text{mm}$ (T-1) all plastic mold type
- Low power consumption

Outline Dimensions

unit : mm

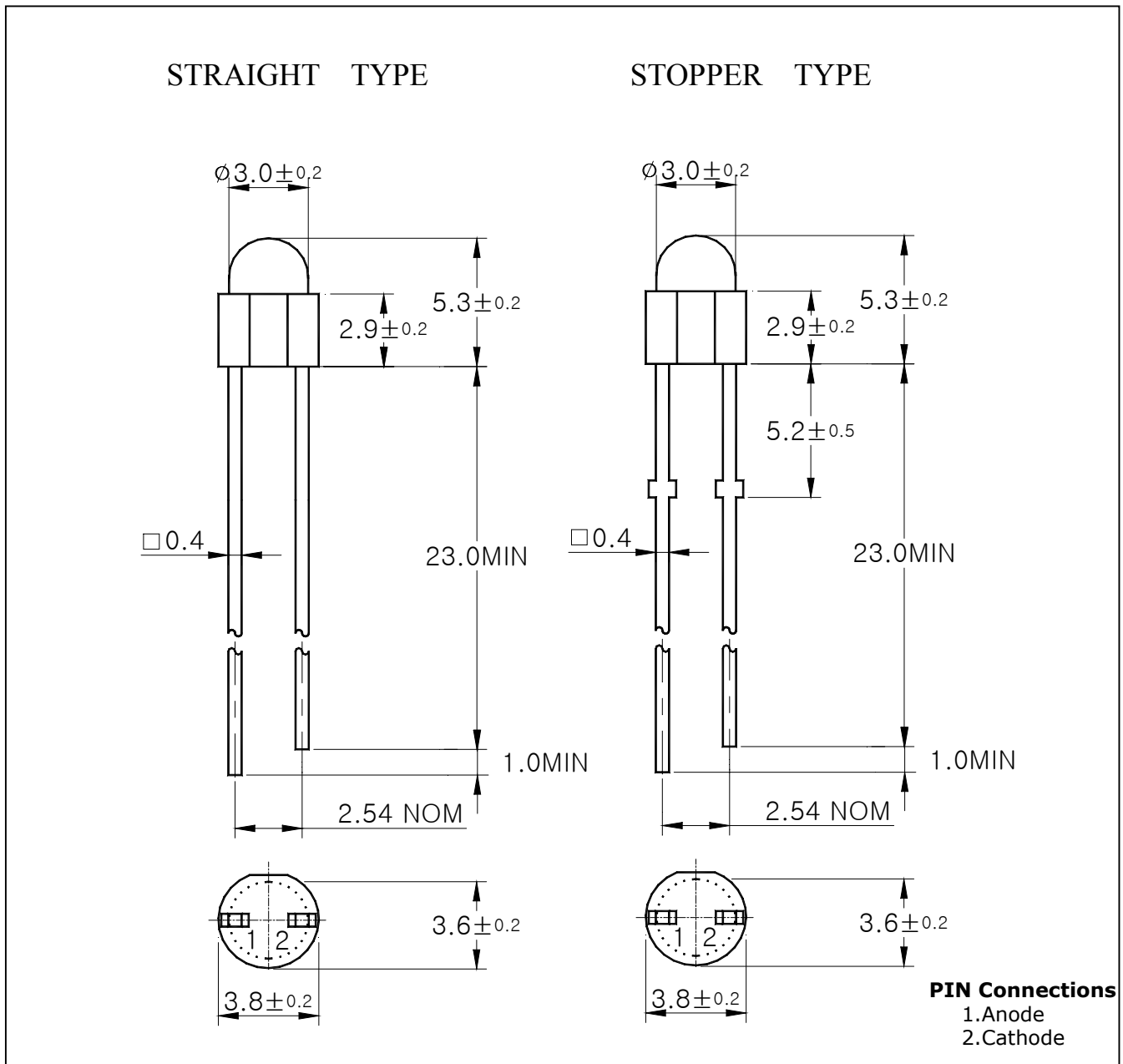

Absolute maximum ratings

Characteristic	Symbol	Ratings	Unit
Power Dissipation	P_D	85	mW
Forward Current	I_F	30	mA
*1 Peak Forward Current	I_{FP}	50	mA
Reverse Voltage	V_R	4	V
Operating Temperature	T_{opr}	-25 ~ 85	°C
Storage Temperature	T_{stg}	-30 ~ 100	°C
*2 Soldering Temperature	T_{sol}	260°C for 5 seconds	

*1. Duty ratio = 1/16, Pulse width = 0.1ms

*2. Keep the distance more than 2.0mm from PCB to the bottom of LED package

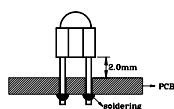

Electrical Characteristics

Characteristic	Symbol	Test Condition	Min.	Typ.	Max.	Unit
Forward Voltage	V_F	$I_F = 20\text{mA}$	-	2.0	2.7	V
Luminous Intensity	I_V	$I_F = 20\text{mA}$	17	43	68	mcd
Peak Wavelength	λ_p	$I_F = 20\text{mA}$	-	585	-	nm
Spectrum Bandwidth	$\Delta \lambda$	$I_F = 20\text{mA}$	-	30	-	nm
Reverse Current	I_R	$V_R = 4\text{V}$	-	-	10	uA
*3 Half angle	$\theta_{1/2}$	$I_F = 20\text{mA}$	-	± 25	-	deg

*3. Luminous Intensity Maximum tolerance for each Grade Classification limit is $\pm 18\%$

*3. Luminous Intensity classification

H	I	J
17~27	27~43	43~68

*4. $\theta_{1/2}$ is the off-axis angle where the luminous intensity is 1/2 the peak intensity

Characteristic Diagrams

Fig. 1 $I_F - V_F$

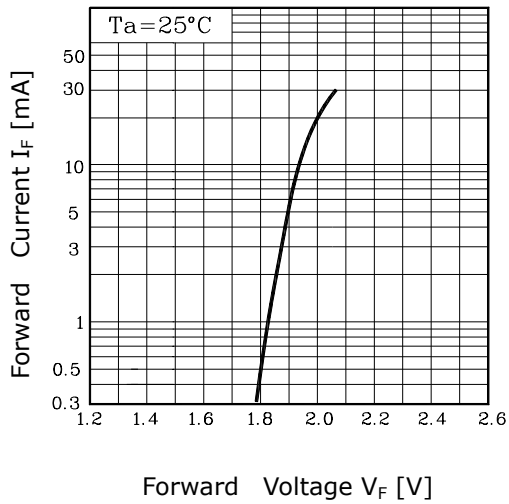

Fig. 2 $I_V - I_F$

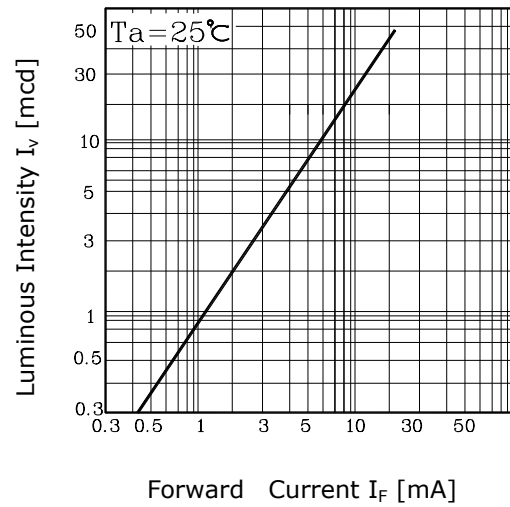

Fig. 3 $I_F - T_a$

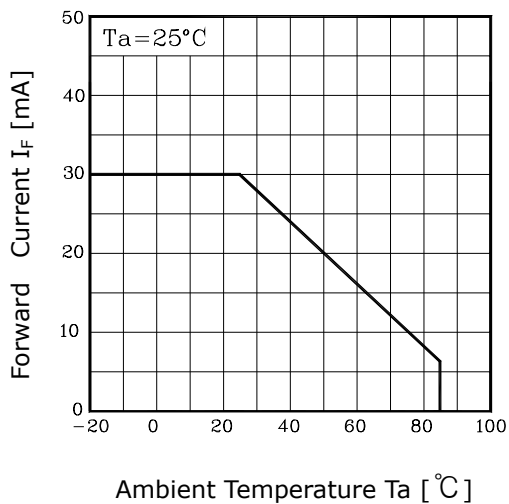

Fig.4 Spectrum Distribution

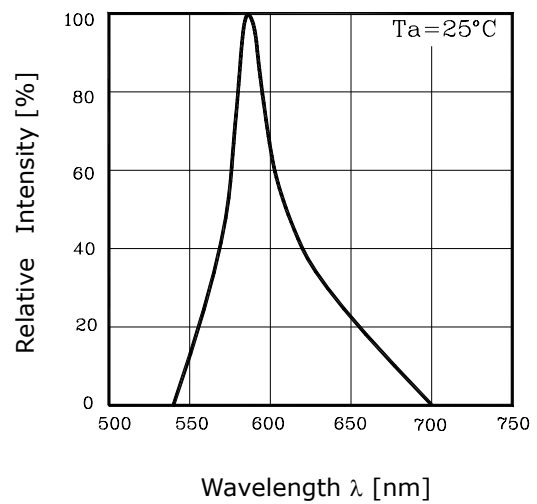

Fig. 5 Radiation Diagram

