

**Microsemi Corp.**

*The diode experts*

SANTA ANA, CA

SCOTTSDALE, AZ

For more information call:  
(602) 941-6300

# MLL5913 thru MLL5956

## DESCRIPTION/FEATURES

- LEADLESS PACKAGE FOR SURFACE MOUNT TECHNOLOGY
- IDEAL FOR HIGH DENSITY MOUNTING
- VOLTAGE RANGE—3.3 TO 200 VOLTS
- HERMETICALLY SEALED, DOUBLE-SLUG GLASS CONSTRUCTION
- METALLURGICALLY ENHANCED CONTACT CONSTRUCTION

## MAXIMUM RATINGS

1.50 Watts DC Power Rating (See Power Derating Curve)  
-65°C to +200°C Operating and Storage Junction Temperature  
Power Derating 10.0 mW/°C above 50°C

## APPLICATION

This surface mountable zener diode series is similar to the 1N5913 thru 1N5956 registration in the DO-41 equivalent package except that it meets the new JEDEC surface mount outline DO-213AB. It is an ideal selection for applications of high density and low parasitic requirements. Due to its glass hermetic qualities, it may also be considered for high reliability applications when required by a source control drawing (SCD).

## LEADLESS GLASS ZENER DIODES

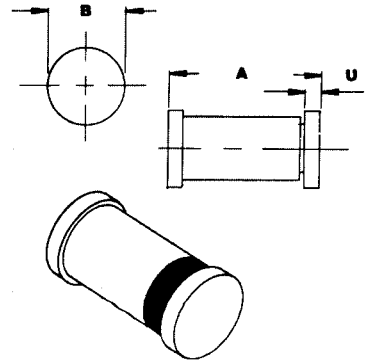

DIM	MILLIMETERS		INCHES	
	MIN	MAX	MIN	MAX
A	4.80	5.20	.189	.205
B	2.39	2.66	.094	.105
U	.41	.55	.016	.022

DO-213AB

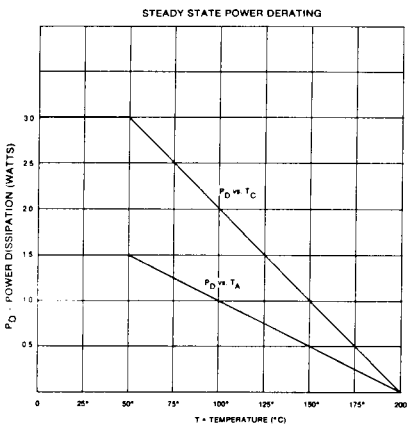

## MECHANICAL CHARACTERISTICS

**CASE:** Hermetically sealed glass with solder contact tabs at each end.

**FINISH:** All external surfaces are corrosion resistant, readily solderable.

**POLARITY:** Banded end is cathode.

**THERMAL RESISTANCE:** 50°C/Watt typical junction to contact (case) tabs. (See Power Derating Curve)

**MOUNTING POSITION:** Any.

# MLL5913 thru MLL5956

## ELECTRICAL CHARACTERISTICS @ $T_C = 30^\circ\text{C}$

JEODEC TYPE NUMBER	ZENER VOLTAGE $V_Z$ (Note 2)	TEST CURRENT $I_{ZT}$	DYNAMIC IMPEDANCE $Z_{ZT}$ (Note 3)	KNEE CURRENT $I_{ZK}$	KNEE IMPEDANCE $Z_{ZK}$ (Note 3)	REVERSE CURRENT $I_R$	REVERSE VOLTAGE $V_R$	MAX. DC CURRENT $I_{ZM}$
(/Note 1)	Volts	mA	$\Omega$	mA	$\Omega$	$\mu\text{A}$	Volts	mA
MLL5913	3.3	1136	10	1.0	500	100	1.0	454
MLL5914	3.6	1042	9.0	1.0	500	75	1.0	416
MLL5915	3.9	961	7.5	1.0	500	25	1.0	384
MLL5916	4.3	872	6.0	1.0	500	5.0	1.0	348
MLL5917	4.7	798	5.0	1.0	500	5.0	1.5	319
MLL5918	5.1	735	4.0	1.0	350	5.0	2.0	294
MLL5919	5.6	669	2.0	1.0	250	5.0	3.0	267
MLL5920	6.2	605	2.0	1.0	200	5.0	4.0	241
MLL5921	6.8	551	2.5	1.0	200	5.0	5.2	220
MLL5922	7.5	50	3.0	0.5	400	5.0	6.0	200
MLL5923	8.2	45.7	3.5	0.5	400	5.0	6.5	182
MLL5924	9.1	41.2	4.0	0.5	500	5.0	7.0	164
MLL5925	10	37.5	4.5	0.25	500	5.0	8.0	150
MLL5926	11	34.1	5.5	0.25	5.0	10	8.4	138
MLL5927	12	31.2	6.5	0.25	550	1.0	9.1	125
MLL5928	13	28.8	7.0	0.25	550	1.0	9.9	115
MLL5929	15	25	9.0	0.25	600	1.0	11.4	100
MLL5930	16	23.4	10	0.25	600	1.0	12.2	93
MLL5931	18	20.8	12	0.25	650	1.0	13.7	83
MLL5932	20	18.7	14	0.25	650	1.0	15.2	75
MLL5933	22	17	17.5	0.25	650	1.0	16.7	68
MLL5934	24	15.6	19	0.25	700	1.0	18.2	62
MLL5935	27	13.9	23	0.25	700	1.0	20.6	55
MLL5936	30	12.5	28	0.25	750	1.0	22.9	50
MLL5937	33	11.4	33	0.25	800	1.0	25.1	45
MLL5938	36	10.4	38	0.25	850	1.0	27.4	41
MLL5939	39	9.6	45	0.25	900	1.0	29.7	38
MLL5940	43	8.7	53	0.25	950	1.0	32.7	34
MLL5941	47	8.0	67	0.25	1000	1.0	35.8	31
MLL5942	51	7.3	70	0.25	1100	1.0	38.8	29
MLL5943	56	6.7	86	0.25	1300	1.0	42.6	26
MLL5944	62	6.0	100	0.25	1500	1.0	47.1	24
MLL5945	68	5.5	120	0.25	1700	1.0	51.2	22
MLL5946	75	5.0	140	0.25	2000	1.0	56	20
MLL5947	82	4.6	160	0.25	2500	1.0	62.2	18
MLL5948	91	4.1	200	0.25	3000	1.0	69.2	16
MLL5949	100	3.7	250	0.25	3100	1.0	76	15
MLL5950	110	3.4	300	0.25	4000	1.0	83.6	13
MLL5951	120	3.1	380	0.25	4500	1.0	91.2	12
MLL5952	130	2.9	450	0.25	5000	1.0	98.9	11
MLL5953	150	2.5	600	0.25	6000	1.0	114	10
MLL5954	160	2.3	700	0.25	6500	1.0	121.6	9.0
MLL5955	180	2.1	900	0.25	7000	1.0	136.8	8.0
MLL5956	200	1.9	1200	0.25	8000	1.0	152	7.0

CAPACITANCE vs.  $V_Z$  CURVE

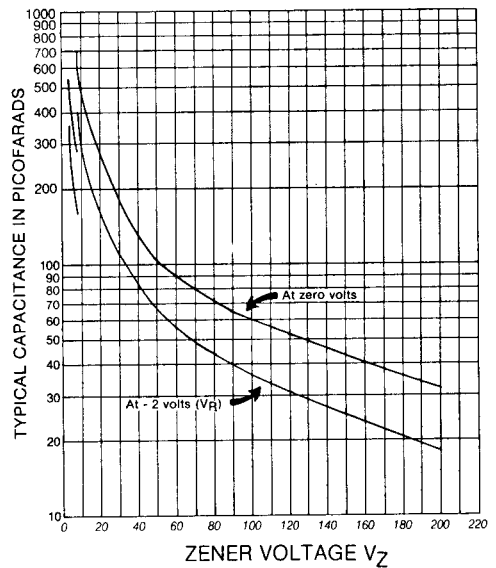

$T_C$  Maintained at  $30^\circ\text{C}$ ,  $V_F = 1.2\text{ V max @ } I_F = 200\text{ mA}$  (all types)

**NOTE 1:** No suffix indicates a  $\pm 20\%$  tolerance on nominal  $V_Z$ . The suffix A denotes  $\pm 10\%$ , B denotes  $\pm 5\%$ , C denotes  $\pm 2\%$ , and D denotes  $\pm 1\%$  tolerance.

**NOTE 2:** Zener voltage ( $V_Z$ ) is measured at  $T_C = 30^\circ\text{C}$ . Voltage measurement to be performed 90 seconds after application of DC current.

**NOTE 3:** The zener impedance is derived from the 60 Hz ac voltage, which results when an ac current having an rms value equal to 10% of the DC zener current ( $I_{ZT}$  or  $I_{ZK}$ ) is superimposed on  $I_{ZT}$  or  $I_{ZK}$ .