

Product Features

- DC – 6000 MHz
- +8 dBm P1dB at 900 MHz
- +21 dBm OIP3 at 900 MHz
- 19.5 dB Gain at 900 MHz
- Single Voltage Supply
- SOT-86 SMT Package
- Internally matched to 50 Ω

Applications

- Mobile Infrastructure
- CATV / DBS
- W-LAN / ISM
- RFID
- Defense / Homeland Security
- Fixed Wireless

Product Description

The AG203-86 is a general-purpose buffer amplifier that offers high dynamic range in a low-cost surface-mount package. At 900 MHz, the AG203-86 typically provides 19.5 dB of gain, +21 dBm Output IP3, and +8 dBm P1dB. The device combines dependable performance with consistent quality to maintain MTTF values exceeding 100 years at mounting temperatures of +85° C and is housed in a SOT-86 (micro-X) industry-standard SMT package.

The AG203-86 consists of Darlington pair amplifiers using the high reliability InGaP/GaAs HBT technology process technology and only requires DC-blocking capacitors, a bias resistor, and an inductive RF choke for operation.

The broadband MMIC amplifier can be directly applied to various current and next generation wireless technologies such as GPRS, GSM, CDMA, and W-CDMA. In addition, the AG203-86 will work for other various applications within the DC to 6 GHz frequency range such as CATV and fixed wireless.

Functional Diagram

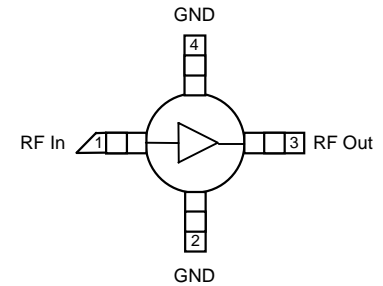

Function	Pin No.
Input	1
Output/Bias	3
Ground	2, 4

Specifications

Parameter	Units	Min	Typ	Max
Frequency Range	MHz	DC	900	6000
Gain (900 MHz)	dB		19.4	
Gain (1900 MHz)	dB	16.2	17.2	18.2
Input Return Loss	dB		25	
Output Return Loss	dB		15	
Output P1dB	dBm		+8.0	
Output IP3 (2)	dBm		+20.8	
Output IP2	dBm		+25	
Noise Figure	dB		3.1	
Device Voltage	V		4.05	
Device Current	mA		20	
Thermal Resistance	°C / W			457
Junction Temperature (3)	°C			177

Test conditions unless otherwise noted.

1. T = 25° C, Supply Voltage = +5 V, R_{bias} = 47.5 Ω, Frequency = 900 MHz, 50 Ω System.
2. 3OIP measured with two tones at an output power of -10 dBm/tone separated by 10 MHz. The suppression on the largest IM3 product is used to calculate the 3OIP using a 2:1 rule.
3. The junction temperature ensures a minimum MTTF rating of 1 million hours of usage.

Typical Performance

Parameter	Units	Typical			
Frequency	MHz	500	900	1900	2140
S21	dB	20	19.4	17.2	16.6
S11	dB	-25	-25	-20	-16
S22	dB	-15	-15	-15	-15
Output P1dB	dBm	+8.1	+8.0	+7.3	+7.2
Output IP3	dBm	+20.8	+20.8	+20.7	+20.5
Noise Figure	dB	3.1	3.1	3.3	3.3

Test conditions: T = 25° C, Supply Voltage = +5 V, R_{bias} = 47.5 Ω, 50 Ω System.

Absolute Maximum Rating

Parameter	Rating
Operating Case Temperature	-40 to +85 °C
Storage Temperature	-55 to +125 °C
DC Voltage	+4.5 V
RF Input Power (continuous)	+10 dBm
Junction Temperature	+250° C

Operation of this device above any of these parameters may cause permanent damage.

Ordering Information

Part No.	Description
AG203-86	InGaP HBT Gain Block
AG203-86PCB	700 – 2400 MHz Fully Assembled Eval. Board

Specifications and information are subject to change without notice

Typical Device RF Performance

Supply Bias = +5 V, $R_{bias} = 47.5 \Omega$, $I_{cc} = 20 \text{ mA}$

Frequency	MHz	100	500	900	1900	2140	2400	3500	5800
S21	dB	20.2	20.0	19.4	17.2	16.6	16.0	14.1	10.7
S11	dB	-20	-25	-25	-20	-16	-16	-16	-16
S22	dB	-13	-15	-15	-15	-15	-14	-18	-15
Output P1dB	dBm	+8.2	+8.1	+8.0	+7.3	+7.2	+7.2	+6.5	
Output IP3	dBm	+21.0	+20.8	+20.8	+20.7	+20.5	+20.3		
Noise Figure	dB	3.1	3.1	3.1	3.3	3.3	3.4		

1. Test conditions: T = 25° C, Supply Voltage = +5 V, Device Voltage = 4.05 V, $R_{bias} = 47.5 \Omega$, $I_{cc} = 20 \text{ mA}$ typical, 50 Ω System.
2. 3OIP measured with two tones at an output power of -10 dBm/tone separated by 10 MHz. The suppression on the largest IM3 product is used to calculate the 3OIP using a 2:1 rule.
3. Data is shown as device performance only. Actual implementation for the desired frequency band will be determined by external components shown in the application circuit.

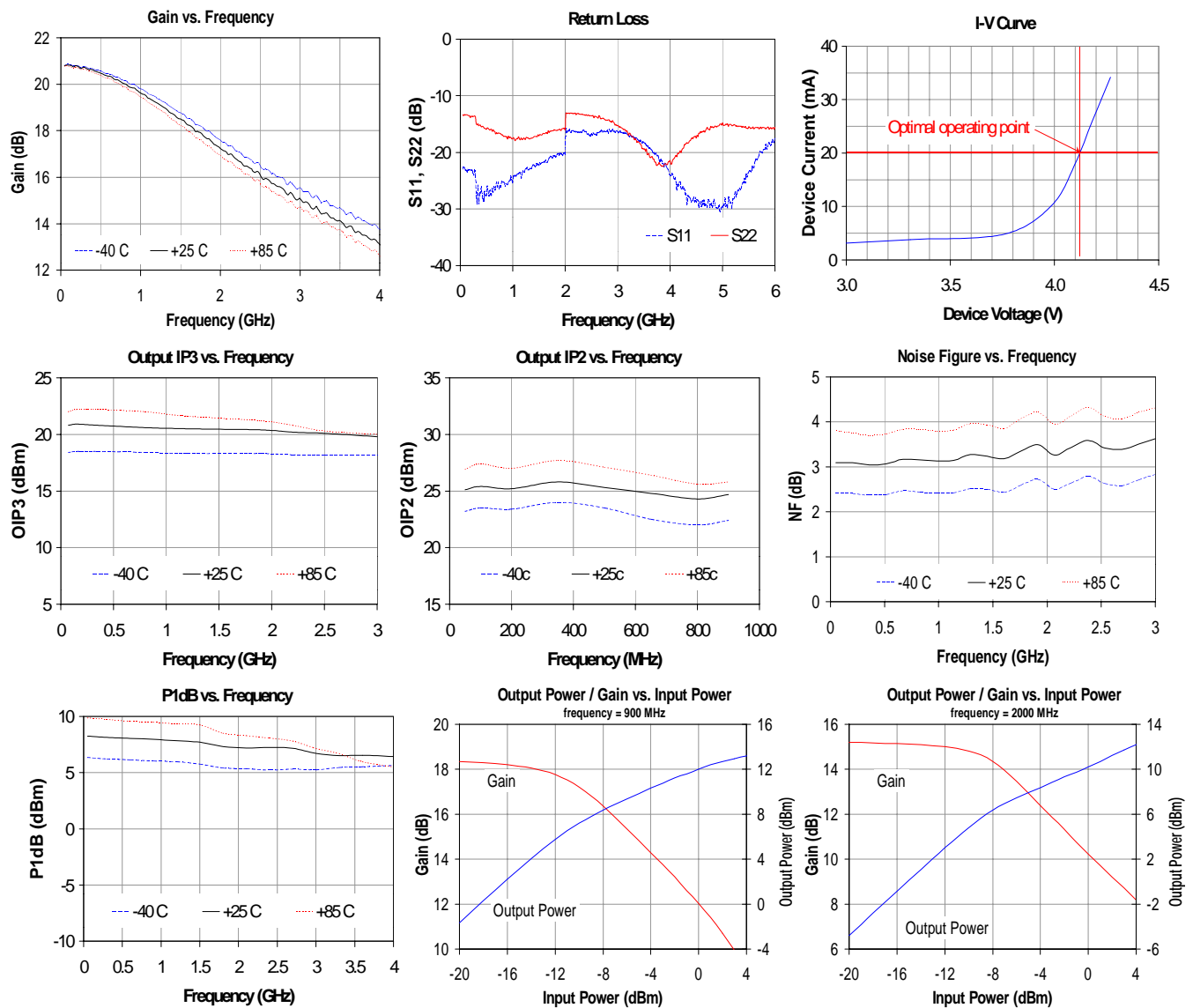



Typical Device RF Performance (cont'd)

Supply Bias = +6 V, $R_{bias} = 98 \Omega$, $I_{cc} = 20 \text{ mA}$

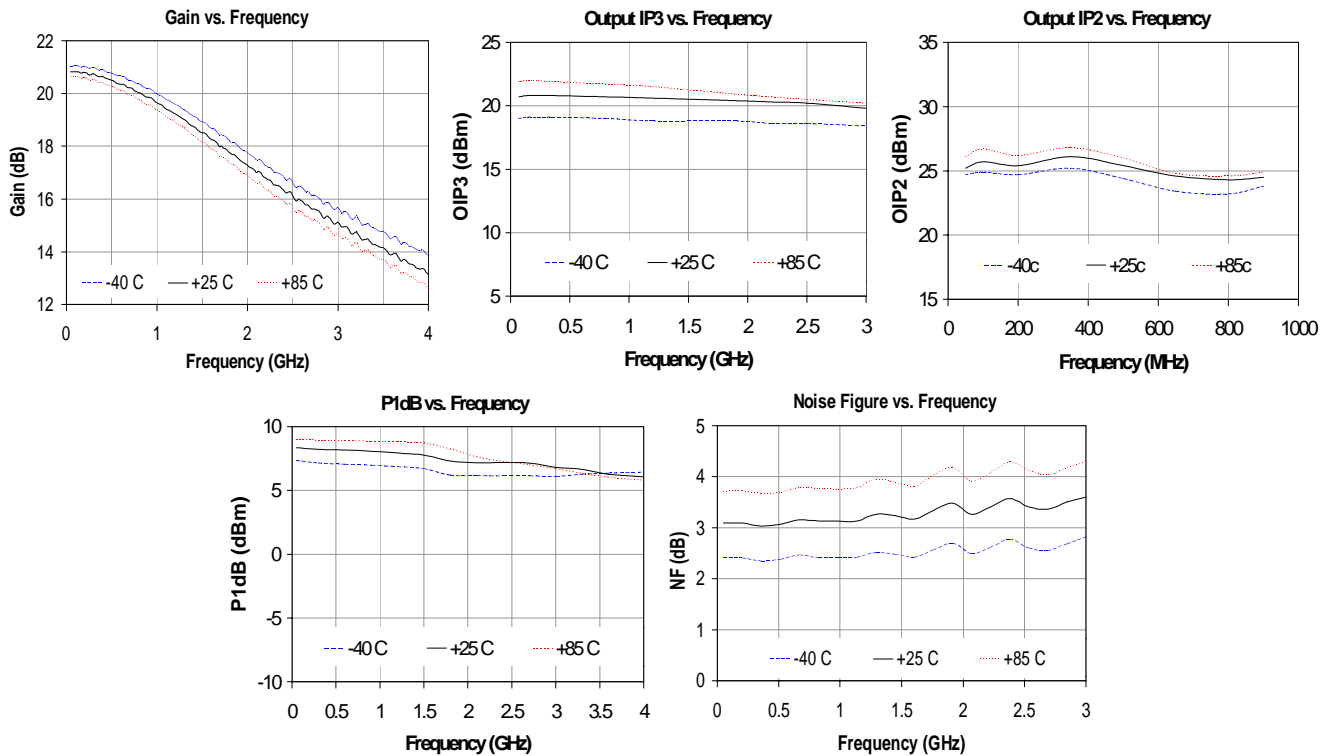

Typical Device RF Performance

Supply Bias = +8 V, $R_{bias} = 198 \Omega$, $I_{cc} = 20 \text{ mA}$

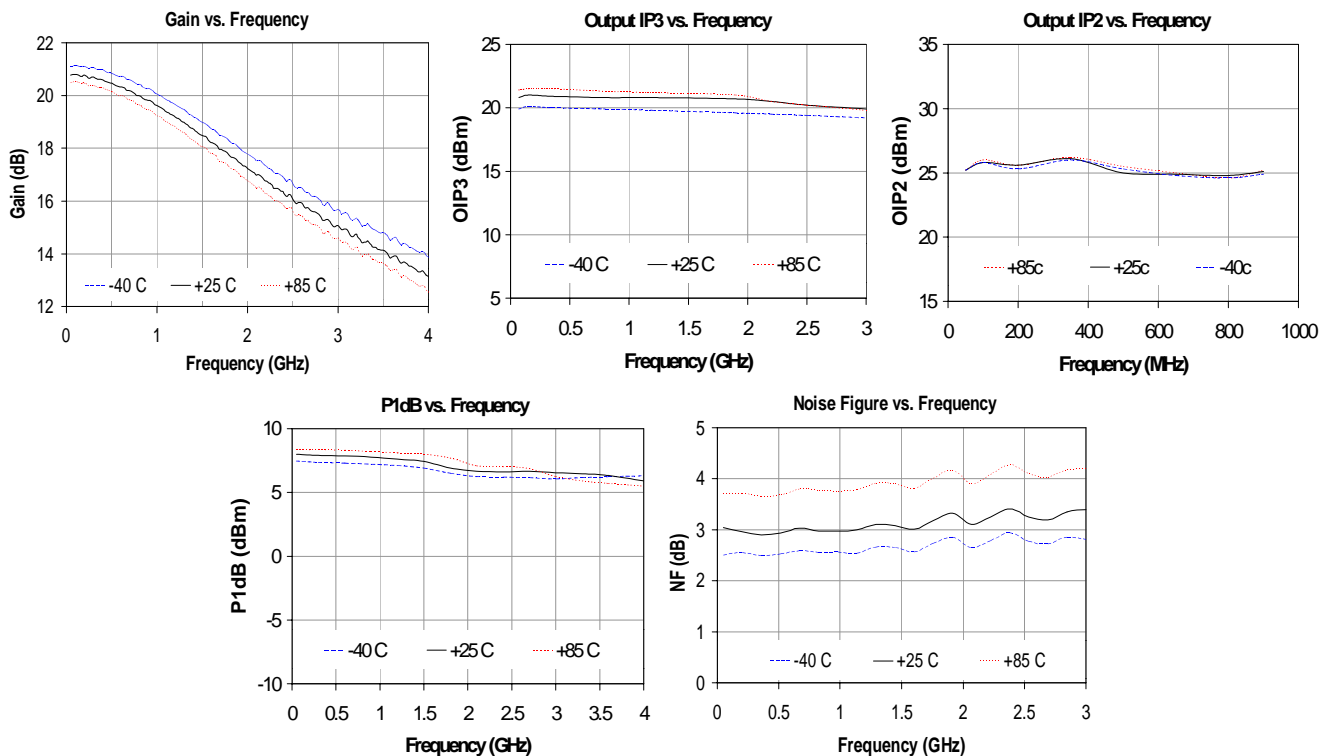

Specifications and information are subject to change without notice

Application Circuit

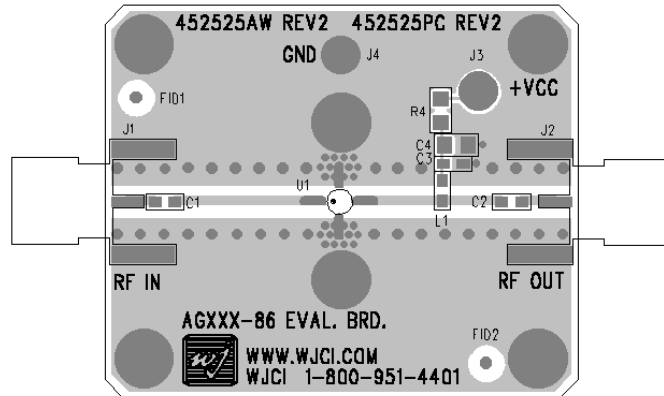
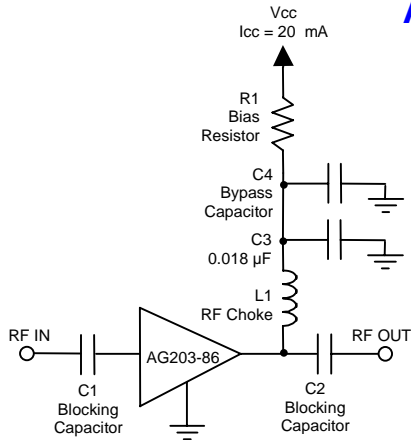

Recommended Component Values

Reference Designator	Frequency (MHz)						
	50	500	900	1900	2200	2500	3500
L1	820 nH	220 nH	68 nH	27 nH	22 nH	18 nH	15 nH
C1, C2, C4	.018 μ F	1000 pF	100 pF	68 pF	68 pF	56 pF	39 pF

- The proper values for the components are dependent upon the intended frequency of operation.
- The following values are contained on the evaluation board to achieve optimal broadband performance:

Ref. Desig.	Value / Type	Size
L1	39 nH wirewound inductor	0603
C1, C2	56 pF chip capacitor	0603
C3	0.018 μ F chip capacitor	0603
C4	Do Not Place	
R1	47.5 Ω 1% tolerance	0603

Recommended Bias Resistor Values

Supply Voltage	R1 value	Size
5 V	47.5 ohms	0603
6 V	98 ohms	0603
7 V	148 ohms	0805
8 V	198 ohms	0805
9 V	248 ohms	1206
10 V	298 ohms	1210
12 V	398 ohms	1210

The proper value for R1 is dependent upon the supply voltage and allows for bias stability over temperature. WJ recommends a minimum supply bias of +5 V. A 1% tolerance resistor is recommended.



AG203-86

InGaP HBT Gain Block

The Communications Edge™

Product Information

Outline Drawing

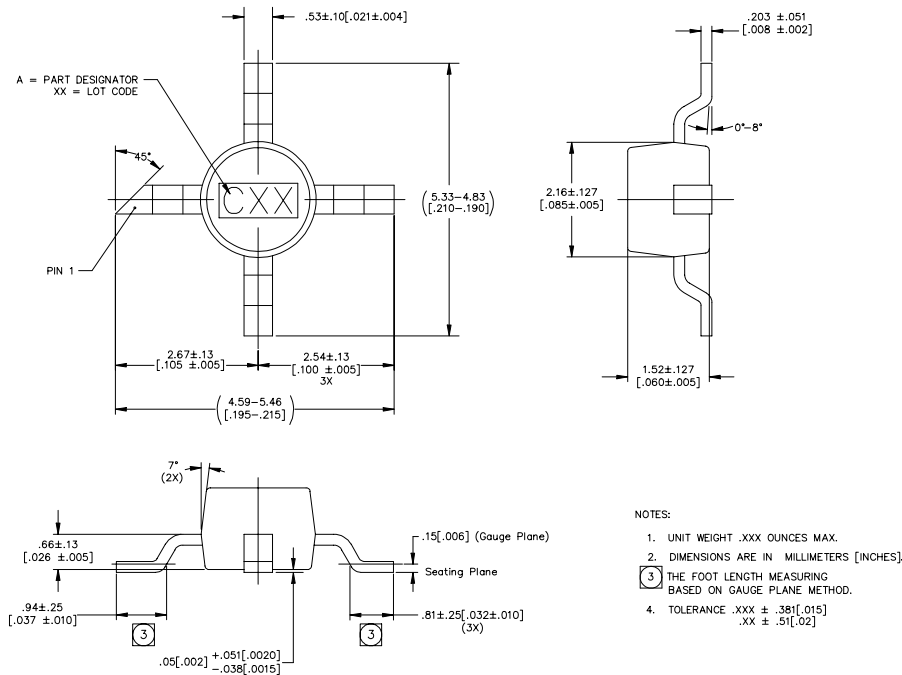

Product Marking

The component will be marked with a "C" designator followed by a two-digit numeric lot code on the top surface of the package.

Tape and reel specifications for this part are located on the website in the "Application Notes" section.

MSL / ESD Rating



Caution! ESD sensitive device.

ESD Rating: Class 0

Value: Passes at 150 V

Test: Human Body Model (HBM)

Standard: JEDEC Standard JESD22-A114

ESD Rating: Class II

Value: Passes at 250 V

Test: Charged Device Model (CDM)

Standard: JEDEC Standard JESD22-C101

MSL Rating: Level 1 at 240° C Reflow

Standard: JEDEC Standard J-STD-020A

Land Pattern

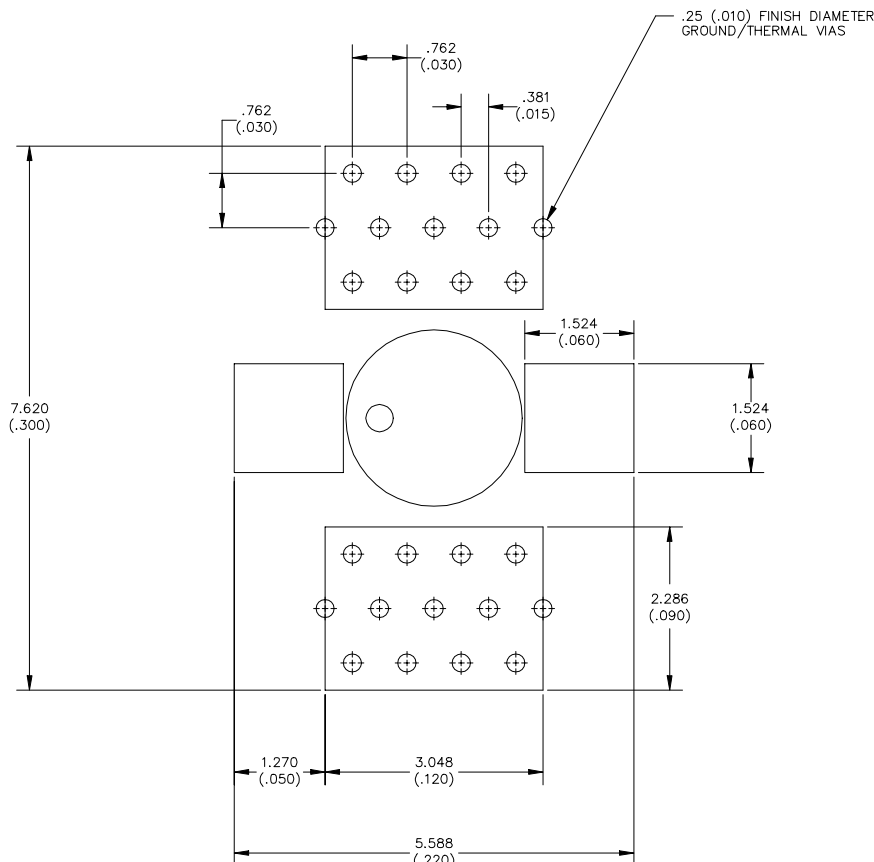

Mounting Config. Notes

1. GROUND/THERMAL VIAS ARE CRITICAL FOR THE PROPER PERFORMANCE OF THIS DEVICE. VIAS SHOULD USE A .35mm (#80/.0135") DIAMETER DRILL AND HAVE A FINAL, PLATED THRU DIAMETER OF .25mm (.010").
2. ADD AS MUCH COPPER AS POSSIBLE TO INNER AND OUTER LAYERS NEAR THE PART TO ENSURE OPTIMAL THERMAL PERFORMANCE.
3. ADD MOUNTING SCREWS NEAR THE PART TO FASTEN THE BOARD TO A HEATSINK. ENSURE THAT THE GROUND/THERMAL VIA REGION CONTACTS THE HEATSINK.
4. DO NOT PUT SOLDER MASK ON THE BACK SIDE OF THE PC BOARD IN THE REGION WHERE THE BOARD CONTACTS THE HEATSINK.
5. RF TRACE WIDTH DEPENDS UPON THE PC BOARD MATERIAL AND CONSTRUCTION.
6. USE 1 OZ. COPPER MINIMUM.
7. ALL DIMENSIONS ARE IN MILLIMETERS (INCHES). ANGLES ARE IN DEGREE

Specifications and information are subject to change without notice



AG203-86

InGaP HBT Gain Block

The Communications Edge™

Product Information

Typical Device Data

S-Parameters ($V_{\text{device}} = +4.05 \text{ V}$, $I_{\text{CC}} = 20 \text{ mA}$, $T = 25^\circ \text{ C}$, calibrated to device leads)

Freq (MHz)	S11 (dB)	S11 (ang)	S21 (dB)	S21 (ang)	S12 (dB)	S12 (ang)	S22 (dB)	S22 (ang)
50	-22.84	-0.07	20.75	177.32	-23.39	0.76	-13.40	-3.20
200	-23.16	7.26	20.67	169.51	-23.89	0.72	-13.69	-8.91
400	-26.05	17.95	20.58	159.07	-24.02	3.44	-15.51	-19.91
600	-27.06	23.98	20.34	148.98	-23.71	0.78	-16.08	-30.27
800	-25.26	28.66	20.08	139.34	-23.61	1.70	-16.90	-43.93
1000	-25.11	29.08	19.67	129.97	-23.71	-0.82	-17.55	-58.52
1200	-23.42	24.60	19.28	120.69	-22.94	0.39	-17.57	-74.82
1400	-22.23	17.76	18.85	112.26	-22.95	1.10	-17.27	-86.89
1600	-21.68	9.52	18.37	104.21	-22.62	0.70	-16.68	-98.63
1800	-20.62	-1.53	17.89	96.70	-22.33	-0.41	-16.08	-105.85
2000	-19.51	-8.95	17.41	89.13	-22.18	2.42	-15.55	-110.13
2200	-16.37	-10.26	16.92	82.75	-22.12	-0.36	-13.21	-104.81
2400	-16.34	-18.68	16.49	76.18	-21.66	-0.78	-13.36	-108.92
2600	-16.87	-28.99	16.24	71.72	-21.72	-6.63	-13.77	-111.04
2800	-16.22	-36.77	15.84	65.46	-21.09	-5.18	-14.33	-115.12
3000	-16.36	-40.45	15.44	59.03	-20.69	-4.81	-15.24	-120.33
3200	-16.95	-44.36	15.09	53.29	-20.51	-7.70	-16.75	-125.06
3400	-17.88	-48.27	14.78	47.44	-20.28	-7.23	-18.16	-134.28
3600	-19.24	-49.28	14.44	41.40	-19.79	-9.69	-20.38	-149.83
3800	-21.57	-50.17	14.14	35.77	-19.53	-14.59	-22.02	-177.00
4000	-24.06	-47.33	13.82	29.86	-19.34	-14.68	-21.48	152.21
4200	-25.76	-32.95	13.45	24.24	-19.02	-19.18	-19.88	131.18
4400	-28.66	-18.83	13.16	18.45	-18.93	-21.24	-17.65	121.75
4600	-29.25	0.59	12.83	12.69	-18.49	-24.00	-16.45	116.53
4800	-29.46	2.34	12.52	7.35	-18.04	-26.94	-15.51	114.82
5000	-29.66	-6.98	12.26	1.83	-17.90	-29.89	-14.84	117.23
5200	-28.28	-42.78	11.97	-3.20	-17.95	-33.52	-15.23	121.04
5400	-25.39	-71.30	11.68	-7.99	-17.74	-35.28	-15.49	129.05
5600	-22.54	-82.53	11.46	-13.21	-17.35	-39.18	-15.84	138.14
5800	-19.45	-95.75	11.20	-18.04	-17.26	-41.72	-15.66	147.73
6000	-17.60	-100.20	10.98	-22.74	-17.06	-44.67	-15.62	155.14

Device S-parameters are available for download off of the website at: <http://www.wj.com>