



# Single-PLL General-Purpose EPROM Programmable Clock Generator

Features	Benefits
Single phase-locked loop architecture	Generates a custom frequency from an external source
EPROM programmability	Easy customization and fast turnaround
Factory-programmable (CY2071A, CY2071AI) or field-programmable (CY2071AF, CY2071AFI) device options	Programming support available for all opportunities
Up to three configurable outputs	Generates three related frequencies from a single device
Low-skew, low-jitter, high-accuracy outputs	Meets critical industry standard timing requirements
Internal loop filter	Alleviates the need for external components
Power management (OE)	Supports low-power applications
Frequency select options	3 outputs with 2 user selectable frequencies
Configurable 5V or 3.3V operation	Supports industry standard design platforms
8-pin 150-mil SOIC package	Industry-standard packaging saves on board space

## Selector Guide

Part Number	Outputs	Input Frequency Range	Output Frequency Range	Specifics
CY2071A	3	10 MHz–25 MHz (external crystal) 1 MHz–30 MHz (reference clock)	500 kHz–130 MHz (5V) 500 kHz–100 MHz (3.3V)	Factory Programmable Commercial Temperature
CY2071AI	3	10 MHz–25 MHz (external crystal) 1 MHz–30 MHz (reference clock)	500 kHz–100 MHz (5V) 500 kHz–80 MHz (3.3V)	Factory Programmable Industrial Temperature
CY2071AF	3	10 MHz–25 MHz (external crystal) 1 MHz–30 MHz (reference clock)	500 kHz–100 MHz (5V) 500 kHz–80 MHz (3.3V)	<b>Field Programmable</b> Commercial Temperature
CY2071AFI	3	10 MHz–25 MHz (external crystal) 1 MHz–30 MHz (reference clock)	500 kHz–90 MHz (5V) 500 kHz–66.6 MHz (3.3V)	<b>Field Programmable</b> Industrial Temperature

## Logic Block Diagram for CY2071A

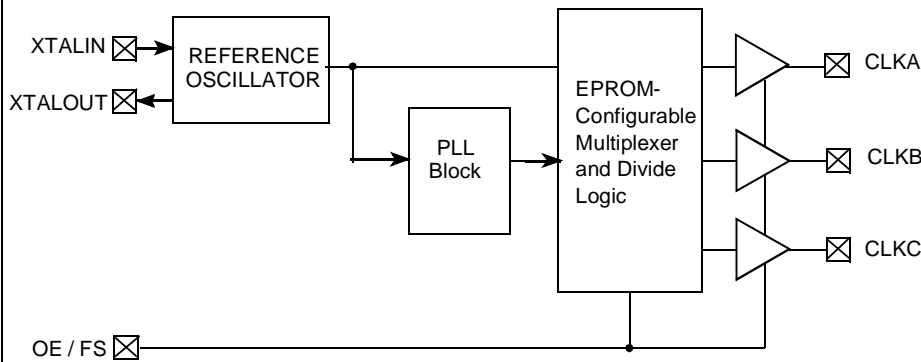

## Pin Configuration

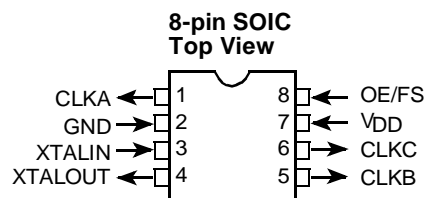

**Pin Summary**

Name	Number	Description
CLKA	1	Configurable Clock Output
GND	2	Ground
XTALIN <sup>[1]</sup>	3	Reference Crystal Input or External Reference Clock Input
XTALOUT <sup>[1, 2]</sup>	4	Reference Crystal Feedback
CLKB	5	Configurable Clock Output
CLKC	6	Configurable Clock Output
V <sub>DD</sub>	7	Voltage Supply
OE / FS	8	Output Control Pin, either Output Enable or Frequency Select Input (Active-HIGH, internal pull-up resistor to V <sub>DD</sub> )

**Notes:**

- For best accuracy, use a parallel-resonant crystal, C<sub>L</sub> = 17 pF.
- Float XTALOUT pin if XTALIN is driven by reference clock (as opposed to an external crystal).

**Functional Description**

The CY2071A is a general-purpose clock synthesizer designed for use in applications such as modems, disk drives, CD-ROM drives, video CD players, games, set-top boxes, and data/telecommunications. The device offers up to three configurable clock outputs in an 8-pin, 150-mil SOIC package and can operate off either a 3.3V or 5V power supply. The on-chip reference oscillator is designed for 10-MHz to 25-MHz crystals. Alternatively, an external reference clock of frequency between 1 MHz and 30 MHz can be used.

The CY2071A has one PLL and outputs three factory-EPROM configurable clocks: CLKA, CLKB, and CLKC. The output clocks can originate either from the PLL or the reference, or selected dividers thereof. Additionally, pin 8 can be configured to be an Output Enable or a Select input.

The CY2071A can replace multiple Metal Can Oscillators (MCO) in a synchronous system, providing cost and board space savings to the manufacturer. Hence, these devices are ideally suited for applications that require multiple, accurate, and stable clocks synthesized from low-cost generators in small packages. A hard-disk drive is an example of such an application. In this case, CLKA drives the PLL in the Read Controller, while CLKB and CLKC drive the MCU and associated sequencers.

**CyClocks™ Software**

CyClocks is an easy-to-use software application that allows you to configure any one of the EPROM-Programmable Clocks offered by Cypress. You may specify the input frequency, PLL and output frequencies, and different functional options.

Please note the output frequency ranges in this data sheet when specifying them in CyClocks to ensure that you stay within the limits. You can download a copy of CyClocks free on the Cypress Semiconductor website at [www.cypress.com](http://www.cypress.com).

Consider using the CY2081 for applications that require unrelated output frequencies. Consider using the CY2291, CY2292, or CY2907 for applications that require more than three output clocks.

**Cypress FTG Programmer**

The Cypress Frequency Timing Generator (FTG) Programmer is a portable programmer designed to custom program our family of EPROM **Field** Programmable Clock Devices. The FTG programmers connect to a PC serial port and allow users of CyClocks software to quickly and easily program any of the CY2291F, CY2292F, CY2071AF, and CY2907F devices. The ordering code for the Cypress FTG Programmer is CY3670.

**Maximum Ratings**

(Above which the useful life may be impaired. For user guidelines, not tested.)

Supply Voltage.....	-0.5V to +7.0V
DC Input Voltage .....	-0.5V to V <sub>DD</sub> +0.5V
Storage Temperature .....	-65°C to +150°C
Max. Soldering Temperature (10 sec) .....	260°C
Junction Temperature .....	150°C
Static Discharge Voltage .....	>2000V (per MIL-STD-883, Method 3015)

**Operating Conditions<sup>[3]</sup>**

Parameter	Description	Min.	Max.	Unit
V <sub>DD</sub>	Supply Voltage, 5.0V Operation	4.5	5.5	V
V <sub>DD</sub>	Supply Voltage, 3.3V Operation	3.0	3.6	V
T <sub>A</sub>	Commercial Operating Temperature, Ambient	0	70	°C
	Industrial Operating Temperature, Ambient	-40	85	°C
C <sub>L</sub>	Max. Load Capacitance per Output (5V Operation)		25	pF
	Max. Load Capacitance per Output (3.3V Operation)		15	pF
f <sub>REF</sub>	External Reference Crystal	10.0	25.0	MHz
	External Reference Clock <sup>[4, 5]</sup>	1.0	30.0	MHz

**Electrical Characteristics, Commercial 5.0V** V<sub>DD</sub> = 5V ±10%, T<sub>A</sub> = 0°C to +70°C

Parameter	Description	Conditions	Min.	Typ.	Max.	Unit
V <sub>OH</sub>	HIGH-Level Output Voltage	I <sub>OH</sub> = -4.0 mA	2.4			V
V <sub>OL</sub>	LOW-Level Output Voltage	I <sub>OL</sub> = 4.0 mA			0.4	V
V <sub>IH</sub>	HIGH-Level Input Voltage <sup>[6]</sup>	Except Crystal Pins	2.0			V
V <sub>IL</sub>	LOW-Level Output Voltage <sup>[6]</sup>	Except Crystal Pins			0.8	V
I <sub>IH</sub>	Input HIGH Current	V <sub>IN</sub> = V <sub>DD</sub> - 0.5V			10	μA
I <sub>IL</sub>	Input LOW Current	V <sub>IN</sub> = 0.5V			150	μA
I <sub>OZ</sub>	Output Leakage Current	Three State Outputs			250	μA
I <sub>DD</sub>	V <sub>DD</sub> Supply Current <sup>[7]</sup>	V <sub>DD</sub> = V <sub>DD</sub> max. 5V operation, C <sub>L</sub> = 25 pF		40	60	mA

**Electrical Characteristics, Commercial 3.3V** V<sub>DD</sub> = 3.3V ±10%, T<sub>A</sub> = 0°C to +70°C

Parameter	Description	Conditions	Min.	Typ.	Max.	Unit
V <sub>OH</sub>	HIGH-Level Output Voltage	I <sub>OH</sub> = -4.0 mA	2.4			V
V <sub>OL</sub>	LOW-Level Output Voltage	I <sub>OL</sub> = 4.0 mA			0.4	V
V <sub>IH</sub>	HIGH-Level Input Voltage <sup>[6]</sup>	Except Crystal Pins	2.0			V
V <sub>IL</sub>	LOW-Level Output Voltage <sup>[6]</sup>	Except Crystal Pins			0.8	V
I <sub>IH</sub>	Input HIGH Current	V <sub>IN</sub> = V <sub>DD</sub> - 0.5V			10	μA
I <sub>IL</sub>	Input LOW Current	V <sub>IN</sub> = 0.5V			150	μA
I <sub>OZ</sub>	Output Leakage Current	Three State Outputs			250	μA
I <sub>DD</sub>	V <sub>DD</sub> Supply Current <sup>[7]</sup>	V <sub>DD</sub> = V <sub>DD</sub> max. 3.3V operation, C <sub>L</sub> = 15 pF		24	40	mA

**Notes:**

- Electrical parameters are guaranteed with these operating conditions. Values for 3.3V operation are shown in parentheses.
- External input reference clock must have a duty cycle between 40% and 60%, measured at V<sub>DD</sub>/2.
- Please refer to application note "Crystal Oscillator Topics" for information on AC-coupling the external input reference clock.
- Xtal inputs have CMOS thresholds.
- Load = max, typical configuration, f<sub>REF</sub> = 14.318 MHz. Specific configurations may vary. A close approximation of I<sub>DD</sub> can be derived by the following formula:  

$$I_{DD}(mA) = V_{DD} * (6.25 + (0.055 * f_{REF}) + (0.0017 * C_{LOAD} * (F_{CLKA} + F_{CLKB} + F_{CLKC})))$$
C<sub>LOAD</sub> is specified in pF and F is specified in MHz.

**Electrical Characteristics, Industrial 5.0V**  $V_{DD} = 5.0V \pm 10\%$ ,  $T_A = -40^\circ\text{C}$  to  $+85^\circ\text{C}$ 

Parameter	Description	Conditions	Min.	Typ.	Max.	Unit
$V_{OH}$	HIGH-Level Output Voltage	$I_{OH} = -4.0\text{ mA}$	2.4			V
$V_{OL}$	LOW-Level Output Voltage	$I_{OL} = 4.0\text{ mA}$			0.4	V
$V_{IH}$	HIGH-Level Input Voltage <sup>[6]</sup>	Except Crystal Pins	2.0			V
$V_{IL}$	LOW-Level Output Voltage <sup>[6]</sup>	Except Crystal Pins			0.8	V
$I_{IH}$	Input HIGH Current	$V_{IN} = V_{DD} - 0.5V$			10	$\mu\text{A}$
$I_{IL}$	Input LOW Current	$V_{IN} = 0.5V$			150	$\mu\text{A}$
$I_{OZ}$	Output Leakage Current	Three State Outputs			250	$\mu\text{A}$
$I_{DD}$	$V_{DD}$ Supply Current <sup>[7]</sup>	$V_{DD} = V_{DD}$ max. 5V operation, $C_L = 25\text{ pF}$		40	75	mA

**Electrical Characteristics, Industrial 3.3V**  $V_{DD} = 3.3V \pm 10\%$ ,  $T_A = -40^\circ\text{C}$  to  $+85^\circ\text{C}$ 

Parameter	Description	Conditions	Min.	Typ.	Max.	Unit
$V_{OH}$	HIGH-Level Output Voltage	$I_{OH} = -4.0\text{ mA}$	2.4			V
$V_{OL}$	LOW-Level Output Voltage	$I_{OL} = 4.0\text{ mA}$			0.4	V
$V_{IH}$	HIGH-Level Input Voltage <sup>[6]</sup>	Except Crystal Pins	2.0			V
$V_{IL}$	LOW-Level Output Voltage <sup>[6]</sup>	Except Crystal Pins			0.8	V
$I_{IH}$	Input HIGH Current	$V_{IN} = V_{DD} - 0.5V$			10	$\mu\text{A}$
$I_{IL}$	Input LOW Current	$V_{IN} = 0.5V$			150	$\mu\text{A}$
$I_{OZ}$	Output Leakage Current	Three State Outputs			250	$\mu\text{A}$
$I_{DD}$	$V_{DD}$ Supply Current <sup>[7]</sup>	$V_{DD} = V_{DD}$ max. 3.3V operation, $C_L = 15\text{ pF}$		24	50	mA

**Switching Characteristics, Commercial 5.0V<sup>[8]</sup>**

Parameter	Name	Description	Min.	Typ.	Max.	Unit	
$t_1$	Output Period	Clock output range 5V operation 25-pF load	CY2071A	7.692 [130 MHz]		2000 [500 kHz]	ns
			CY2071AF	10 [100 MHz]		2000 [500 kHz]	ns
$t_{1A}$	Clock Jitter	Peak-to-peak period jitter ( $t_1$ max. – $t_1$ min.), % of clock period, $f_{OUT} \leq 16\text{ MHz}$		0.8	1	%	
$t_{1B}$	Clock Jitter	Peak-to-peak period jitter ( $16\text{ MHz} \leq f_{OUT} \leq 50\text{ MHz}$ )		350	500	ps	
$t_{1C}$	Clock Jitter <sup>[9]</sup>	Peak-to-peak period jitter ( $f_{OUT} \geq 50\text{ MHz}$ )		250	350	ps	
	Output Duty Cycle	Duty cycle <sup>[10, 11]</sup> for outputs, ( $t_2 \div t_1$ ) $f_{OUT} \leq 60\text{ MHz}$	45%	50%	55%		
	Output Duty Cycle <sup>[9]</sup>	Duty cycle <sup>[11]</sup> for outputs, ( $t_2 \div t_1$ ), $f_{OUT} > 60\text{ MHz}$	40%	50%	60%		
$t_3$	Rise Time <sup>[9]</sup>	Output clock rise time		1.5	2.5	ns	
$t_4$	Fall Time <sup>[9]</sup>	Output clock fall time		1.5	2.5	ns	
$t_5$	Skew	Skew delay between any two outputs with identical frequencies (generated by the PLL)			0.5	ns	

**Notes:**

8. Guaranteed by design, not 100% tested.
9. When the output clock frequency is between 100 MHz and 130 MHz at 5V, the maximum capacitive load for these measurements is 15 pF.
10. Reference Output duty cycle depends on XTALIN duty cycle.
11. Measured at 1.4V.

**Switching Characteristics, Commercial 3.3V<sup>[8]</sup>**

Parameter	Name	Description	Min.	Typ.	Max.	Unit	
t <sub>1</sub>	Output Period	Clock output range 3.3V operation 15-pF load	CY2071AS	10 [100 MHz]		2000 [500 kHz]	ns
			CY2071AF	12.50 [80 MHz]		2000 [500 kHz]	ns
t <sub>1A</sub>	Clock Jitter	Peak-to-peak period jitter (t <sub>1</sub> max. – t <sub>1</sub> min.), % of clock period, f <sub>OUT</sub> ≤ 16 MHz		0.8	1	%	
t <sub>1B</sub>	Clock Jitter	Peak-to-peak period jitter (16 MHz ≤ f <sub>OUT</sub> ≤ 50 MHz)		350	500	ps	
t <sub>1C</sub>	Clock Jitter <sup>[9]</sup>	Peak-to-peak period jitter (f <sub>OUT</sub> ≥ 50 MHz)		250	350	ps	
	Output Duty Cycle	Duty cycle <sup>[10, 11]</sup> for outputs, (t <sub>2</sub> ÷ t <sub>1</sub> ) f <sub>OUT</sub> ≤ 60 MHz	45%	50%	55%		
	Output Duty Cycle <sup>[9]</sup>	Duty cycle <sup>[11]</sup> for outputs, (t <sub>2</sub> ÷ t <sub>1</sub> ), f <sub>OUT</sub> > 60 MHz	40%	50%	60%		
t <sub>3</sub>	Rise Time <sup>[9]</sup>	Output clock rise time		1.5	2.5	ns	
t <sub>4</sub>	Fall Time <sup>[9]</sup>	Output clock fall time		1.5	2.5	ns	
t <sub>5</sub>	Skew	Skew delay between any two outputs with identical frequencies (generated by the PLL)			0.5	ns	

**Switching Characteristics, Industrial 5.0V<sup>[8]</sup>**

Parameter	Name	Description	Min.	Typ.	Max.	Unit	
t <sub>1</sub>	Output Period	Clock output range 5.0V operation 25-pF load	CY2071AI	10 [100 MHz]		2000 [500 kHz]	ns
			CY2071AFI	11.1 [90 MHz]		2000 [500 kHz]	ns
t <sub>1A</sub>	Clock Jitter	Peak-to-peak period jitter (t <sub>1</sub> max. – t <sub>1</sub> min.), % of clock period, f <sub>OUT</sub> ≤ 16 MHz		0.8	1	%	
t <sub>1B</sub>	Clock Jitter	Peak-to-peak period jitter (16 MHz ≤ f <sub>OUT</sub> ≤ 50 MHz)		350	500	ps	
t <sub>1C</sub>	Clock Jitter <sup>[9]</sup>	Peak-to-peak period jitter (f <sub>OUT</sub> ≥ 50 MHz)		250	350	ps	
	Output Duty Cycle	Duty cycle <sup>[10, 11]</sup> for outputs, (t <sub>2</sub> ÷ t <sub>1</sub> ) f <sub>OUT</sub> ≤ 60 MHz	45%	50%	55%		
	Output Duty Cycle <sup>[9]</sup>	Duty cycle <sup>[11]</sup> for outputs, (t <sub>2</sub> ÷ t <sub>1</sub> ), f <sub>OUT</sub> > 60 MHz	40%	50%	60%		
t <sub>3</sub>	Rise time <sup>[9]</sup>	Output clock rise time		1.5	2.5	ns	
t <sub>4</sub>	Fall time <sup>[9]</sup>	Output clock fall time		1.5	2.5	ns	
t <sub>5</sub>	Skew	Skew delay between any two outputs with identical frequencies (generated by the PLL)			0.5	ns	

**Switching Characteristics, Industrial 3.3V<sup>[8]</sup>**

Parameter	Name	Description	Min.	Typ.	Max.	Unit	
t <sub>1</sub>	Output Period	Clock output range 3.3V operation 15-pF load	CY2071AI	12.50 [80 MHz]		2000 [500 kHz]	ns
			CY2071AFI	15.0 [66.6 MHz]		2000 [500 kHz]	ns
t <sub>1A</sub>	Clock Jitter	Peak-to-peak period jitter (t <sub>1</sub> max. – t <sub>1</sub> min.), % of clock period, f <sub>OUT</sub> ≤ 16 MHz		0.8	1	%	
t <sub>1B</sub>	Clock Jitter	Peak-to-peak period jitter (16 MHz ≤ f <sub>OUT</sub> ≤ 50 MHz)		350	500	ps	
t <sub>1C</sub>	Clock Jitter <sup>[9]</sup>	Peak-to-peak period jitter (f <sub>OUT</sub> ≥ 50 MHz)		250	350	ps	
	Output Duty Cycle	Duty cycle <sup>[10, 11]</sup> for outputs, (t <sub>2</sub> ÷ t <sub>1</sub> ) f <sub>OUT</sub> ≤ 60 MHz	45%	50%	55%		
	Output Duty Cycle <sup>[9]</sup>	Duty cycle <sup>[11]</sup> for outputs, (t <sub>2</sub> ÷ t <sub>1</sub> ), f <sub>OUT</sub> > 60 MHz	40%	50%	60%		
t <sub>3</sub>	Rise time <sup>[9]</sup>	Output clock rise time		1.5	2.5	ns	
t <sub>4</sub>	Fall time <sup>[9]</sup>	Output clock fall time		1.5	2.5	ns	
t <sub>5</sub>	Skew	Skew delay between any two outputs with identical frequencies (generated by the PLL)			0.5	ns	

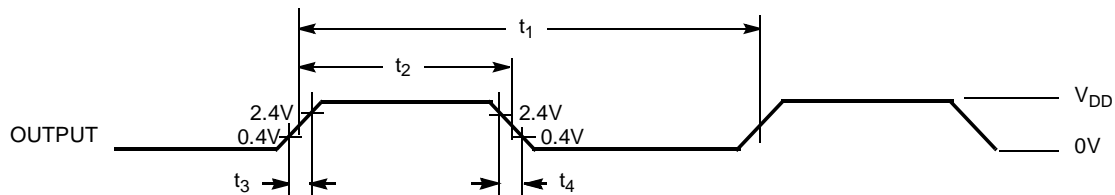
**Switching Waveforms**
**All Outputs Duty Cycle and Rise/Fall Time**

2071A-3

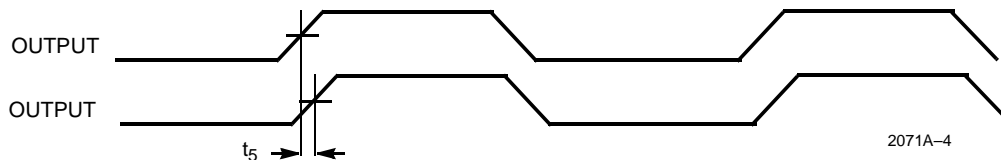
**Output-Output Clock Skew**

2071A-4

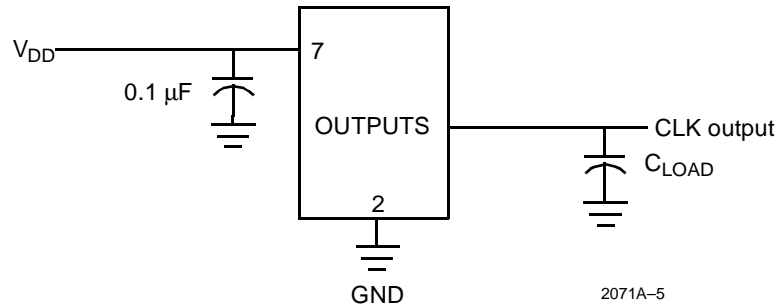
**Test Circuit**

2071A-5

**Ordering Information**

Ordering Code	Package Name	Package Type	Operating Range
CY2071ASC-XXX	S8	8-Pin (150-Mil) SOIC	5.0V, Commercial, Factory Programmable
CY2071ASL-XXX	S8	8-Pin (150-Mil) SOIC	3.3V, Commercial, Factory Programmable
CY2071ASI-XXX	S8	8-Pin (150-Mil) SOIC	5V/3.3V, Industrial, Factory Programmable
CY2071AF	S8	8-Pin (150-Mil) SOIC	5V/3.3V, Commercial, Field Programmable
CY2071AFI	S8	8-Pin (150-Mil) SOIC	5V/3.3V, Industrial, Field Programmable
CY3670		FTG Programmer	Custom programming for Field Programmable Clocks

Document #: 38-00521-D

**Package Characteristics**

Package	$\theta_{JA}$ (C/W)	$\theta_{JC}$ (C/W)	Transistor Count
8 Pin SOIC	170	35	5436

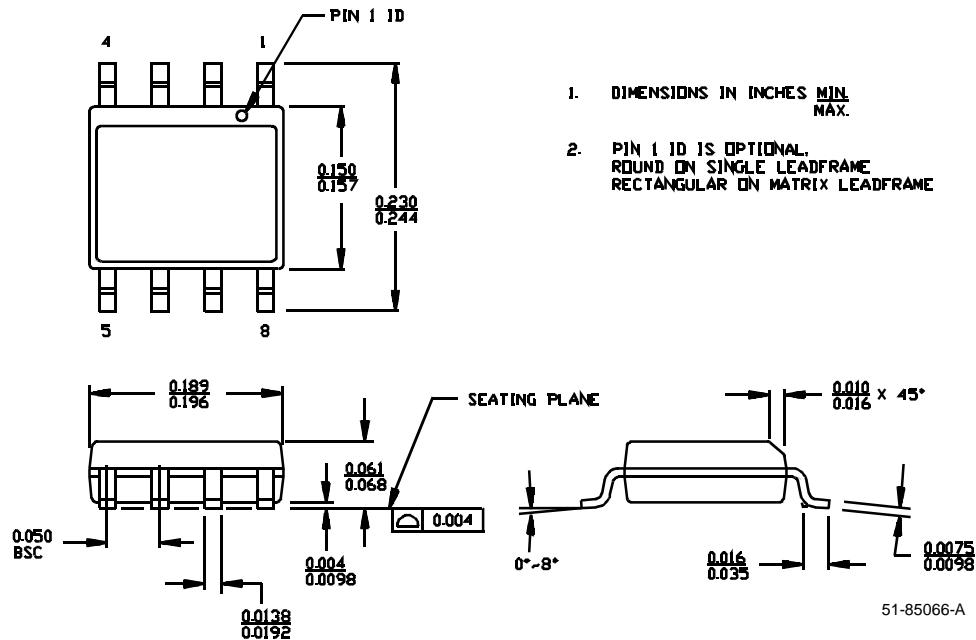
**Package Diagram**
**8-Lead (150-Mil) SOIC S8**

51-85066-A