

TOSHIBA BIPOLAR LINEAR INTEGRATED CIRCUIT SILICON MONOLITHIC

TA8420AF, TA8421AF

1 CHIP DC FAN MOTOR DRIVER

The TA8420AF and TA8421AF are fan motor drive ICs. The output current for these ICs is 1.0A (average). The ICs incorporate all functions necessary for fan motors. By substantially reducing peripheral components, the ICs save space and enhance miniaturization. TA8420AF has an FG output Pin (outputs FG signals in proportion to the number of rotations). TA8421AF has an RD terminal that detects the state of the motor (that is, rotating or stopped). In other respects, the two ICs are the same.

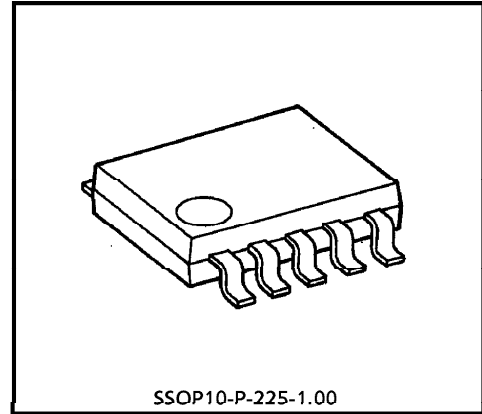

SSOP10-P-225-1.00

Weight : 0.09g (Typ.)

FEATURES

- Build-in Lock Sensing Circuit (Over Heat Protector for Drive Coil).
- Build-in Automatic Self Rotation Recovery Circuit After Release of Motor Locking.
- Operating Voltage : $V_{CC(opr)} = 4 \sim 15V$
- Output Current : $I_O = 1.0A (AVE)$
- Thermal Shutdown Circuit Incorporated.
- Suitable for Super Micro Fan Motor.
- Surface Mountable MFP 10 Package Sealed.
- Less External Component.
- TA8420AF has FG (Frequency Generator) Out for Rotation Speed Sense and TA8421AF has RD (Rotation Detect) Out for Rotate or Stop Sense.

961001EBA1

- TOSHIBA is continually working to improve the quality and the reliability of its products. Nevertheless, semiconductor devices in general can malfunction or fail due to their inherent electrical sensitivity and vulnerability to physical stress. It is the responsibility of the buyer, when utilizing TOSHIBA products, to observe standards of safety, and to avoid situations in which a malfunction or failure of a TOSHIBA product could cause loss of human life, bodily injury or damage to property. In developing your designs, please ensure that TOSHIBA products are used within specified operating ranges as set forth in the most recent products specifications. Also, please keep in mind the precautions and conditions set forth in the TOSHIBA Semiconductor Reliability Handbook.
- The products described in this document are subject to foreign exchange and foreign trade control laws.
- The information contained herein is presented only as a guide for the applications of our products. No responsibility is assumed by TOSHIBA CORPORATION for any infringements of intellectual property or other rights of the third parties which may result from its use. No license is granted by implication or otherwise under any intellectual property or other rights of TOSHIBA CORPORATION or others.
- The information contained herein is subject to change without notice.

BLOCK DIAGRAM

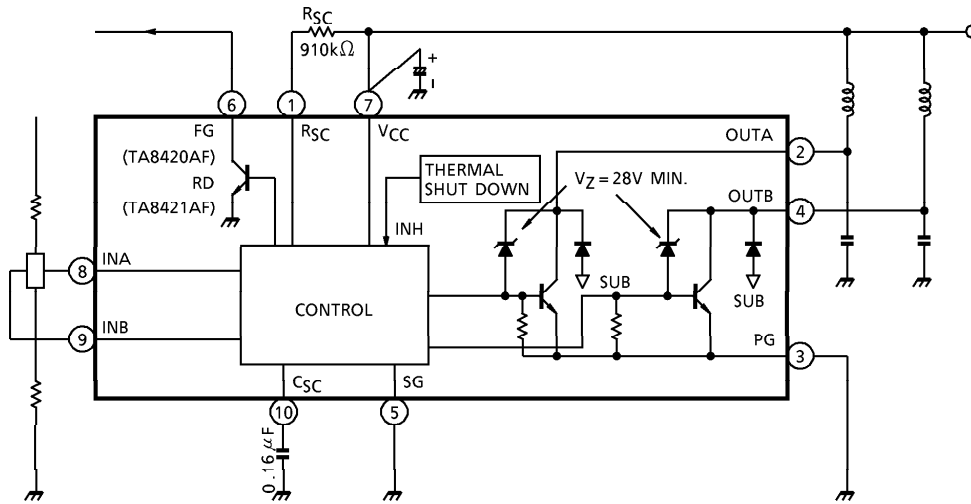

PIN FUNCTION

PIN No.	SYMBOL	FUNCTIONAL DESCRIPTION
1	R _{SC}	Constant Current determine terminal. (for Lock Protect Circuit)
2	OUTA	Output terminal.
3	PG	Power GND.
4	OUTB	Output terminal.
5	SG	Signal GND.
6	FG (TA8420AF)	Rotation speed output terminal.
	RD (TA8421AF)	Rotation detect output terminal.
7	V _{CC}	Power voltage supply terminal.
8	INA	Hall input terminal.
9	INB	Hall input terminal.
10	C _{SC}	Lock protect time constant determine terminal.

OPERATION OF AUTOMATIC SELF RECOVERY CIRCUIT

If Motor Rotation is distorted by external force or obstacles, Over Current, which have a possibility of Drive Coil Burning, is generated by decreasing of Back Electron Motive Force (BEMF).

Therefore, Over Heat Protection of Drive Coil is required for Fan Motor Drive System.

Generally, Series Connection of Temperature Dependence Elements (Posistor) to Output Drive Coil or to use drive IC incorporates protection circuit are required to get coil burning protection.

Posistor is so expensive, therefore, IC's incorporate this function are coming into wider use for Fan Motor Drive in recent years.

Generally, re-switch operation after the turn on of protection circuit is required for system start up again because the circuit is constructed by flip-flop circuits.

But there's no use re-switch operation with TA8420AF, TA8421AF because of build-in automatic self recovery circuit.

Fig.1 shows pin⑩ voltage and the operation of this functions are as follows.

1. Normal rotation states

Internally generated charging current of I_{SL} ($0.25\mu A$ Typ.) charge-ups external capacitance of C_{SC} connected to pin⑩.

But FG pulse, generates among in rotation states and the frequency is proportional to rotation speed, discharges CL charge periodically.

Therefore, voltage of pin⑩ is becoming sawteeth waveform and will not to reach V_{SC} of limiting voltage ($1.3V$ Typ.).

2. Motor lock states

If a Motor is locked by external force or obstacles, internal FG pulse generation is stopped. As a result, the voltage of pin⑩ increase.

Torque generation is stopped after when the voltage of pin⑩ reaches to V_{SC} Further more, voltage of pin⑩ is increased by charging current of I_{SL} toward the V_{SCR} of self recovery voltage ($2.9V$ Typ.).

And then the pin⑩ voltage reaches to V_{SCR} .

Automatic self recovery circuit operates and generates a momentary torque ($t_{ON} = 200ms$. Typ.).

But Motor can not start own rotation if the Motor is still locked by external force or obstacles.

In this period, voltage wave form of pin⑩ is becoming sawteeth that peak is V_{SCR} and Bottom is Minimum DC level of approximately $0.7V$.

3. After release of motor lock

Pin⑩ voltage can not reaches V_{SC} level after release of Motor lock because of discharging operation of C_{SC} .

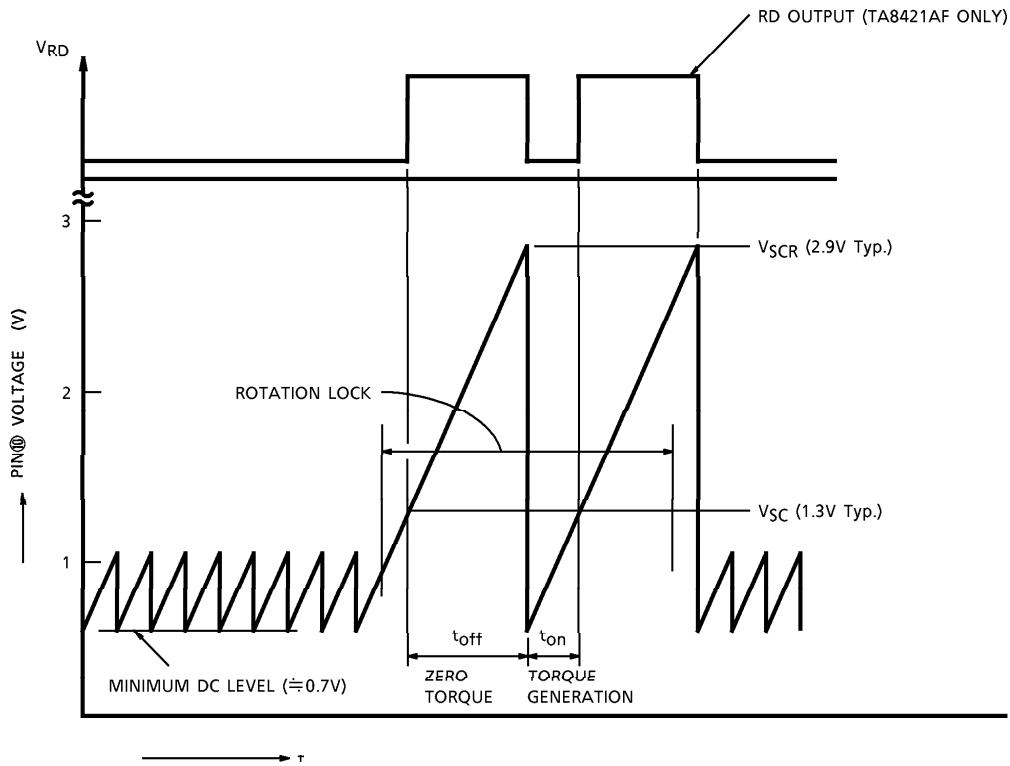

Fig.1 Automatic Self Rotation Recovery Circuit Operation

- FG output (TA8420AF) and RD output (TA8421AF)

FG output terminal of pin⑩ of TA8420AF outputs a rotation speed proportional FG signals with open collector mode.

This FG signal duty and mode are all the same to output A (pin②).

RD output terminal of pin⑩ of TA8421AF outputs a state signals (Rotate or Stop).

RD output becomes low (Actually V_{SAT}(RD) level of 0.3V Typ.) when the Motor in rotation state and generates t_{off} pulse when the rotation is locked (Refer to Fig.1).

- Recommended operating conditions
 TA8420AF, TA8421AF are designed for 5, 12V operating voltage use.
 Please refer to Fig.2 of Recommendation Operating Region.

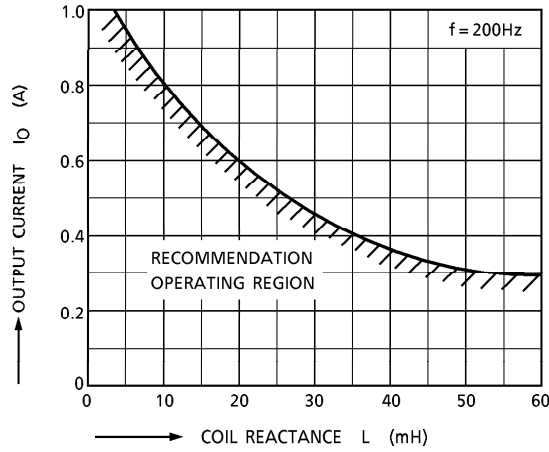

Fig.2 Recommendation operating region

- Transient thermal resistance.

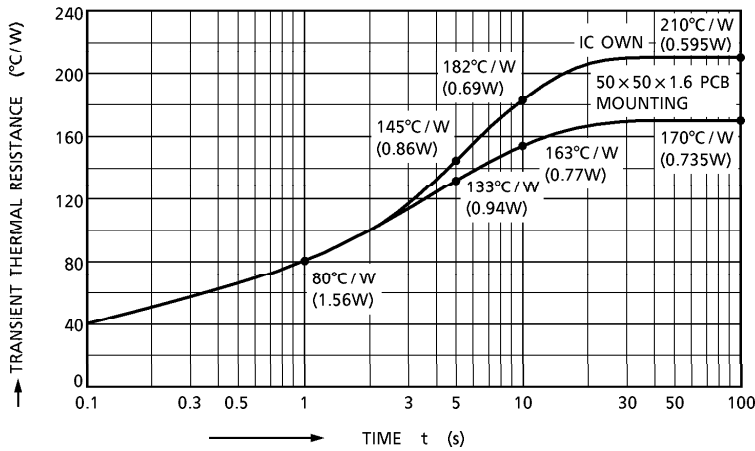

Fig.3 Transient thermal resistance (Single pulse condition)

- Hall input terminals (Pin⑧, ⑨)

Operating DC Level of Hall Inputs (Pin⑧, ⑨) are $2.5 \sim V_{CC} - 0.8V$ as specified.

If the voltage appeared at Hall Sensor output terminal within this range, there's no requirement of external connecting level shifting resistor.

But R_a , (or R_a and R_b) is required to connect series with Hall sensor if this is not.

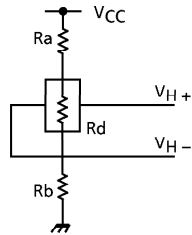

$$2.5 (V) \leq V_{CC} \cdot \frac{R_b + \frac{R_d}{2}}{R_a + R_b + R_d} \leq V_{CC} - 0.8 (V)$$

R_d : Dynamic Resistance of Hall Sensor.

- We recommend to connect noise suppression use capacitance between IN A and IN B for stable operation.

MAXIMUM RATINGS (Ta = 25°C)

CHARACTERISTIC	SYMBOL	RATING	UNIT
Output Terminal Breakdown Voltage Pin②, ④, ⑥	V _{CER}	28	V
Operating Supply Voltage	V _{CC (opr.)}	15	V
Output Current	AVE.	I _{O (AVE.)}	1.0
	PEAK	I _{O (PEAK)}	2.0 (Note 1)
FG Output Current (TA8420AF)	I _{FG}	20 (Note 1)	mA
RD Output Current (TA8421AF)	I _{RD}		
Hall Input Voltage	V _{HM}	300 (Note 2)	mV
Power Dissipation	P _D	735 (Note 3)	mW
Operating Temperature	T _{opr}	-30~85	°C
Storage Temperature	T _{stg}	-50~150	°C

(Note 1) t = 0.1s

(Note 2) T_j = -25~150°C

(Note 3) This value is obtained by 50×50×1.6mm PCB mounting occupied in excess of 30% of copper area.

ELECTRICAL CHARACTERISTICS (Ta = 25°C, V_{CC} = 12V, R_{SC} = 910kΩ, C_{SC} = 0.16μF)

CHARACTERISTIC	SYMBOL	TEST CIRCUIT	TEST CONDITION	MIN.	TYP.	MAX.	UNIT	
Quiescent Current	I _{CC}	—	V _{CC} = 5V, OUT A "ON"	3.0	5.2	7.5	mA	
			V _{CC} = 12V, OUT A "ON"	3.5	5.7	8.0		
Output Saturation Voltage	V _{SAT}	—	I _O = 0.2A, T _j = 25°C	—	0.75	1.0	V	
			I _O = 0.5A, T _j = 25°C	—	0.85	1.3		
			I _O = 1.0A, T _j = 25°C	—	1.0	2.0		
			I _O = 2.0A, T _j = 25°C	—	1.8	2.6		
Automatic Self Rotation Recovery Circuit	Charge Current	I _{SL}	—	—	0.25	—	μA	
	Limiting Voltage	V _{SC}	—	—	1.3	—	V	
	Recovery Voltage	V _{SCR}	—	—	2.9	—		
	On Time	t _{on}	—	—	150	200	700	ms
	Duty Ratio	DR	—	t _{off} / t _{on} , T _j = -25~150°C	3	5	9	—
Hall Input	Sensitivity	V _H	—	Including off set	—	—	7	mV
	Operating DC Level (Lower)	C _{MRL}	—	T _j = -25~150°C	—	—	2.5	V
	Operating DC Level (Upper)	C _{MRH}	—	T _j = -25~150°C	V _{CC} - 0.8	—	—	
FG Output Saturation Voltage (TA8420AF)	V _{SAT (FG)}	—	I _{FG} = 5mA	—	0.3	0.5	V	
RD Output Saturation Voltage (TA8421AF)	V _{SAT (RD)}	—	I _{RD} = 5mA					
Thermal Shutdown Operating Temperature	T _{SD}	—	—	150	—	—	°C	

TEST CIRCUIT

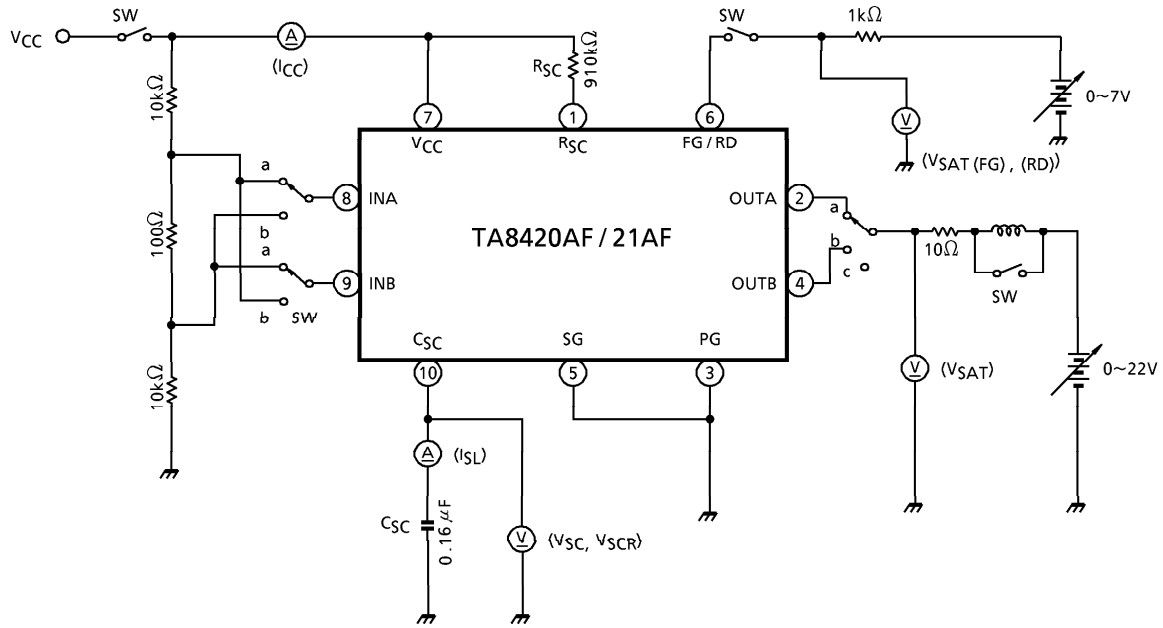

FUNCTION

MODE	IN		OUT	
	A (⑧)	B (⑨)	A (②)	B (④)
MODE1	H	L	ON	OFF
MODE2	L	H	OFF	ON

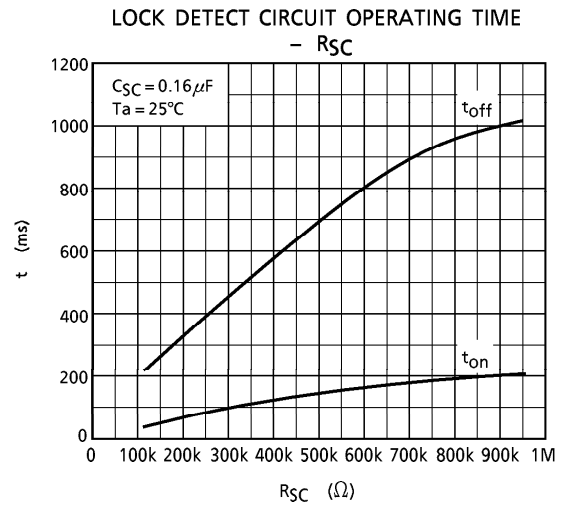
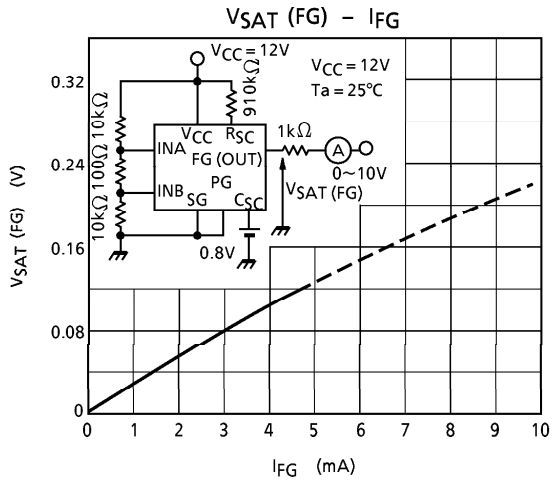
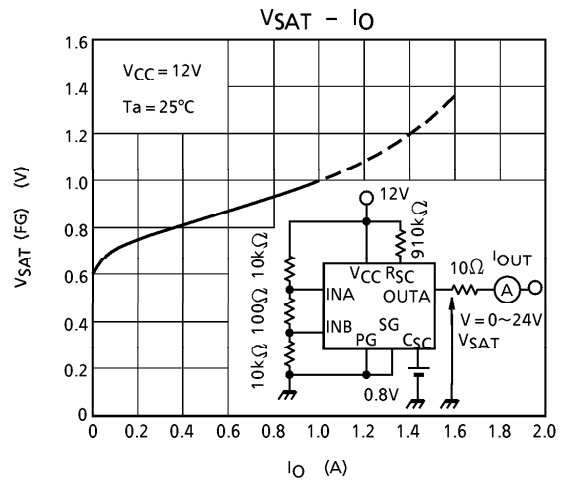
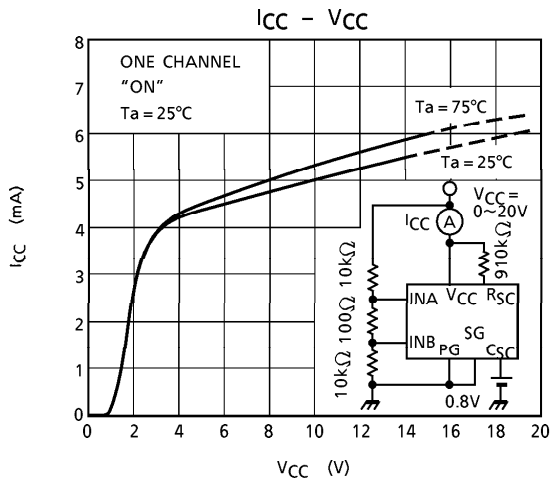

(Note) RD Output is same characteristic.

APPLICATION CIRCUIT

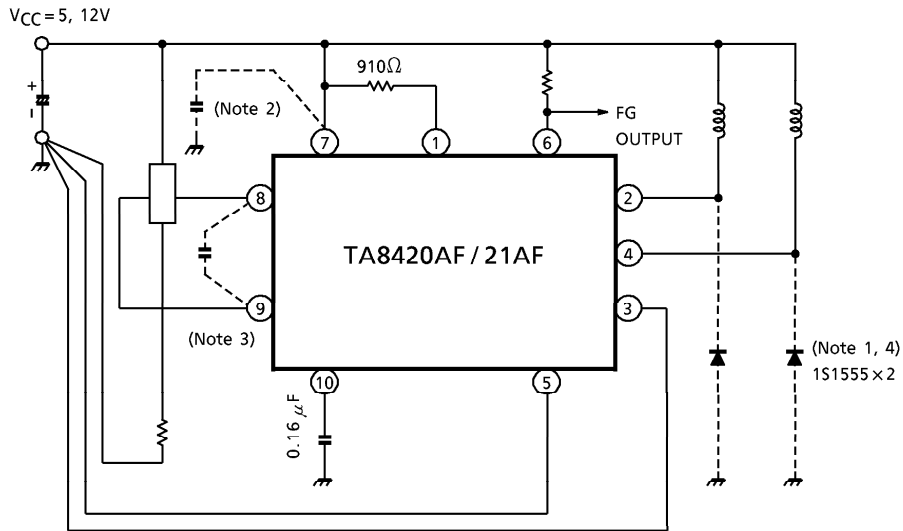

- (Note 1) There's no requirement of this diodes in normal applications. But if the V_{CC} is more than 14V or use large value of coil reactance, we recommend to connect this diodes.
- (Note 2) There's no requirement of this capacitance in normal applications. But connection $0.47\sim 10\mu F$ of this capacitance increases a stability of operation.
- (Note 3) This capacitance is for noise suppression use. Connect if required.
- (Note 4) We recommend to connect capacitance between each output and GND (or out ㉑ and ㉒), to suppress R_{FI} and noise problems.
- (Note 5) Utmost care is necessary in the design of the output line, V_{CC} and GND line since IC may be destroyed due to short-circuit between outputs, air contamination fault, or fault by improper grounding.
- (Note 6) In case of large mutual inductive value between L_a and L_b . Diodes (or CR) are required to restrict parasitic oscillation caused by negative electro-motive force generated by inductive mutual effect between L_a and L_b .

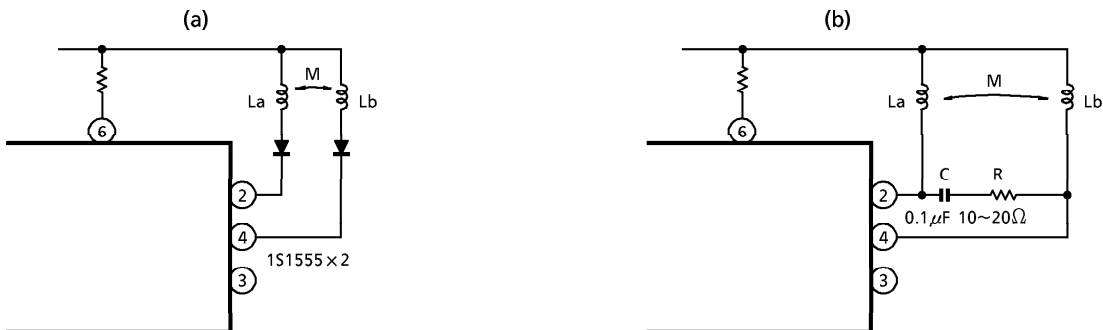

OUTLINE DRAWING
SSOP10-P-225-1.00

Unit : mm

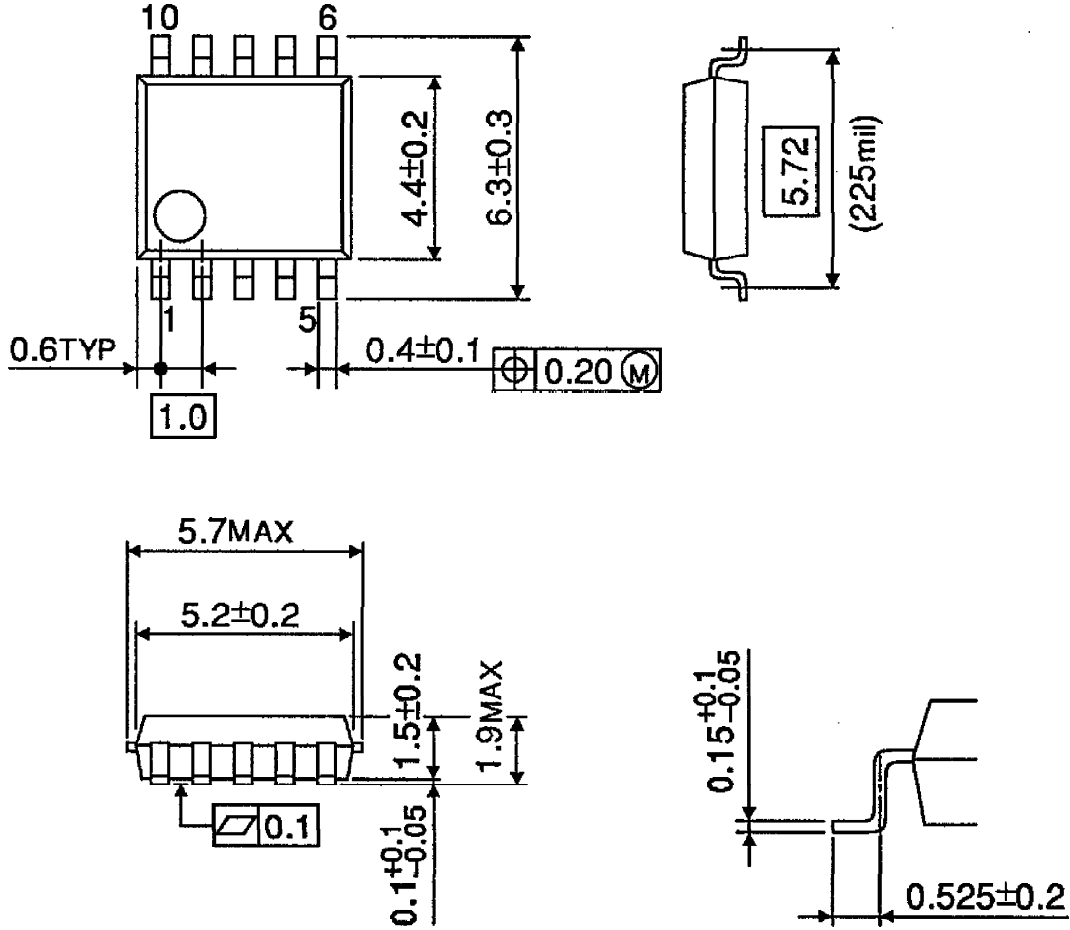

Weight : 0.09g (Typ.)