

SCHEMATIC

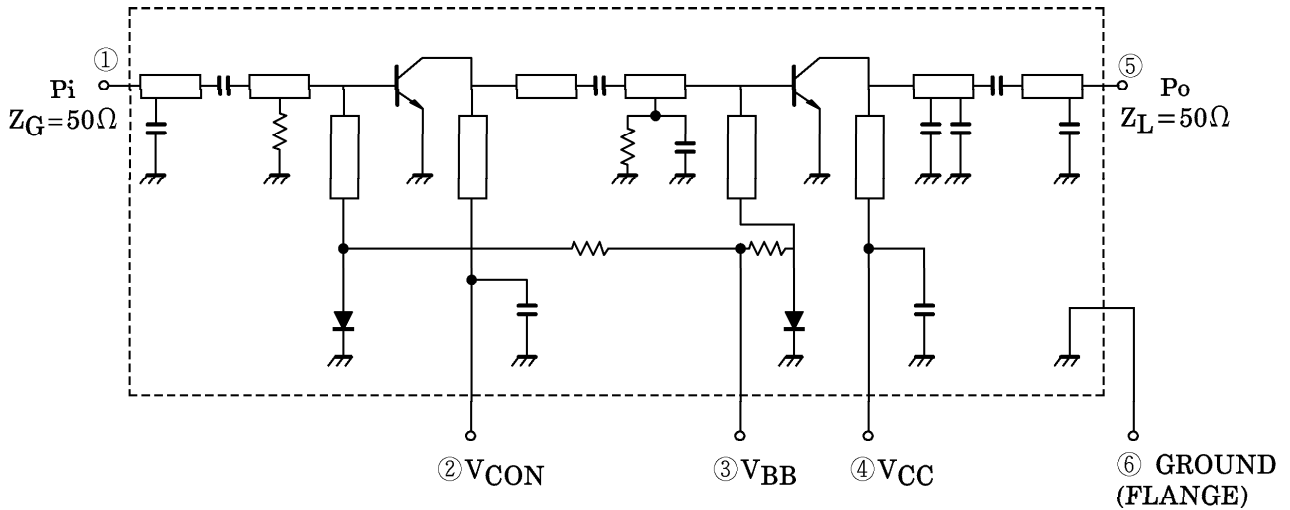

TEST FIXTURE

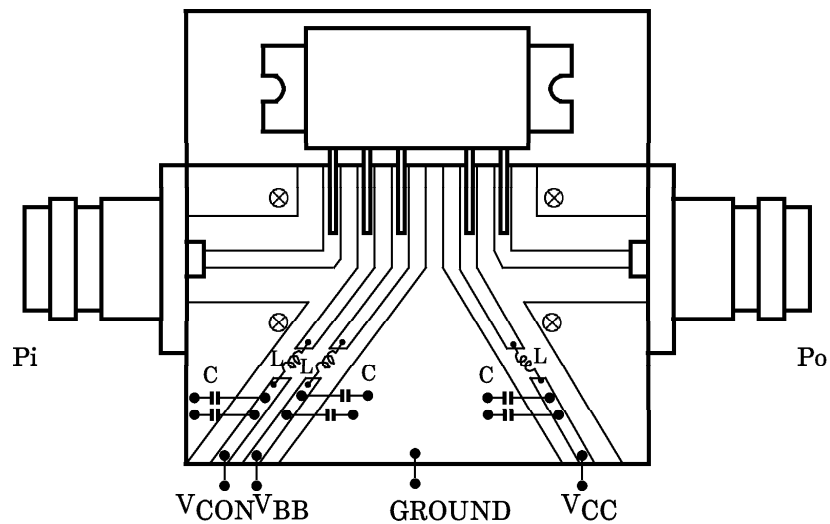

C : 22000pF, 10μF PARALLEL
 L : φ0.5 ENAMEL WIRE 3ID, 5T

961001EAA2'

● The information contained herein is presented only as a guide for the applications of our products. No responsibility is assumed by TOSHIBA CORPORATION for any infringements of intellectual property or other rights of the third parties which may result from its use. No license is granted by implication or otherwise under any intellectual property or other rights of TOSHIBA CORPORATION or others.
 ● The information contained herein is subject to change without notice.

TYPICAL PERFORMANCE CURVES
(S-AU35AH)

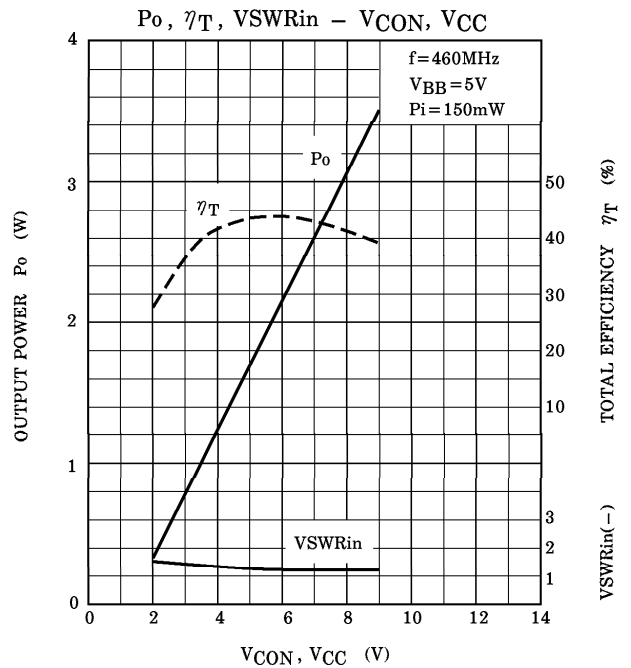
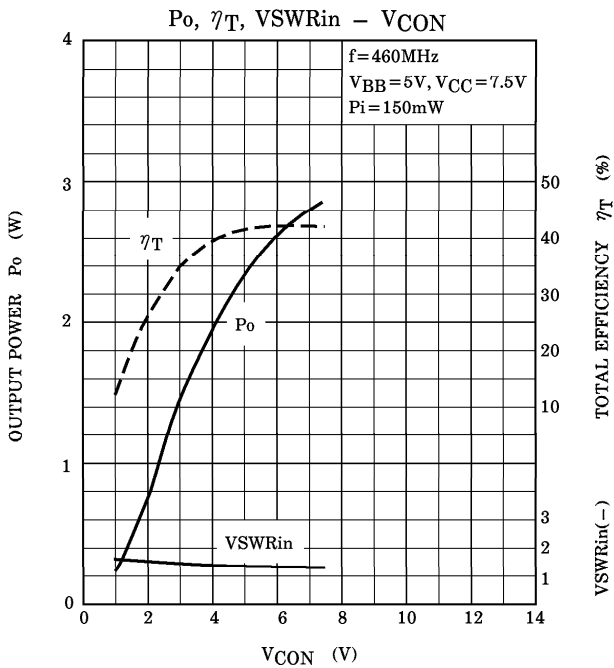
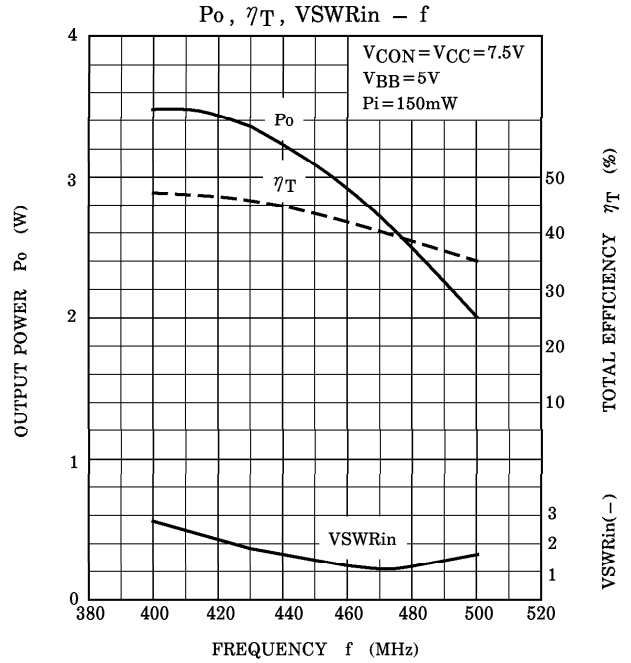
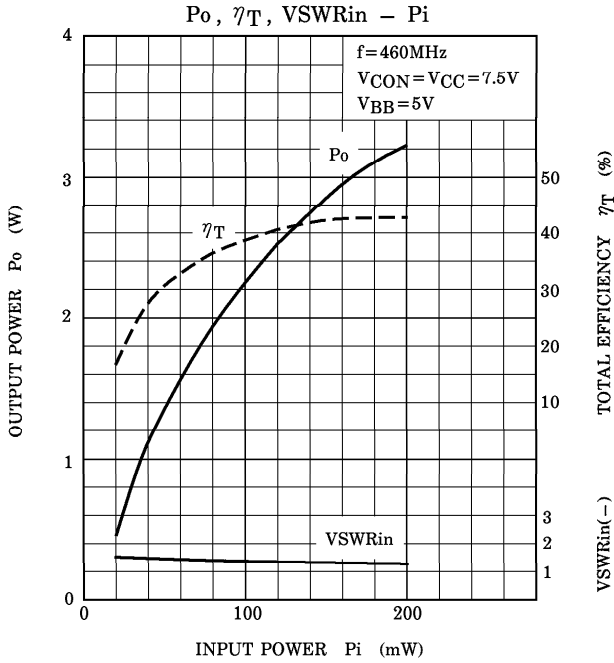

CAUTION

These are only typical curves and devices are not necessarily guaranteed at these curves.