

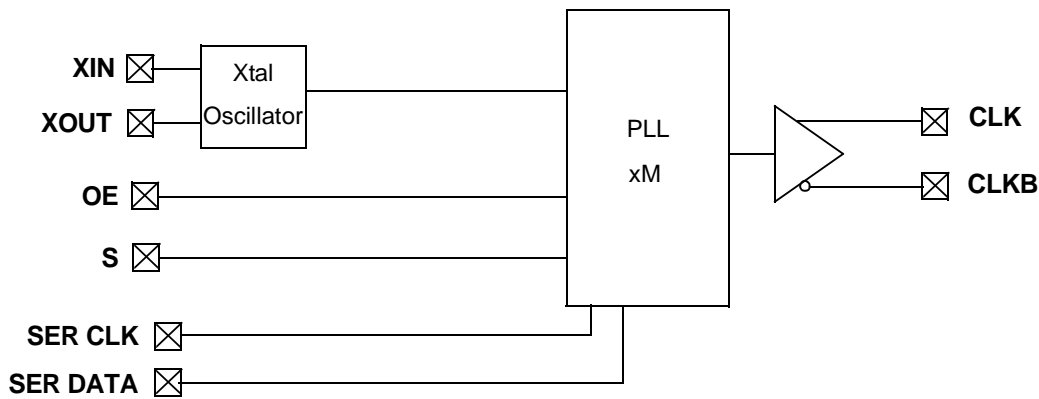

# High-Frequency Programmable PECL Clock Generator

Features	Benefits
• Jitter peak-peak (TYPICAL) = 35 ps	High-accuracy clock generation
• LVPECL output	One pair of differential output drivers
• Default Select option	Phase-locked loop (PLL) multiplier select
• Serially-configurable multiply ratios	Eight-bit feedback counter and six-bit reference counter for high accuracy
• Output edge-rate control	Minimize electromagnetic interference (EMI)
• 16-pin TSSOP	Industry-standard, low-cost package saves on board space
• High frequency	125- to 400-MHz (-1) or to 500-MHz (-2) extended output range for high-speed applications
• 3.3V operation	Enables application compatibility

## Block Diagram



## Pin Configuration

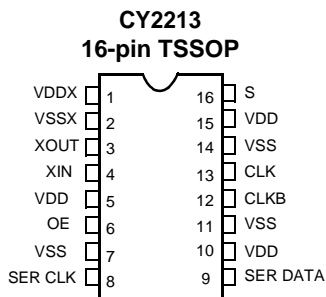

## Pin Description

Pin Name	Pin Number	Pin Description
VDDX	1	3.3V Power Supply for Crystal Driver
VSSX	2	Ground for Crystal Driver
XOUT	3	Reference Crystal Feedback
XIN	4	Reference Crystal Input
VDD	5	3.3 V Power Supply (all V <sub>DD</sub> pins must be tied directly on board)
OE	6	Output Enable, 0 = output disable, 1 = output enable (no internal pull-up)
VSS	7	Ground
SER CLK	8	Serial Interface Clock
SER DATA	9	Serial Interface Data
VDD	10	3.3V Power Supply (all V <sub>DD</sub> pins must be tied directly on board)
VSS	11	Ground
CLKB	12	LVPECL Output Clock (complement)
CLK	13	LVPECL Output Clock
VSS	14	Ground
VDD	15	3.3V Power Supply (all V <sub>DD</sub> pins must be tied directly on board)
S	16	PLL Multiplier Select Input, Pull-up Resistor Internal

## Frequency Table

S	M (PLL Multiplier)	Example Input Crystal Frequency	CLK,CLKB
0	x16	25 MHz	400 MHz
		31.25 MHz	500 MHz
1	x8	15.625 MHz	125 MHz

## CY2213 Two-Wire Serial Interface

### Introduction

The CY2213 has a two-wire serial interface designed for data transfer operations, and is used for programming the P and Q values for frequency generation. S<sub>clk</sub> is the serial clock line controlled by the master device. S<sub>data</sub> is a serial bidirectional data line. The CY2213 is a slave device and can either read or write information on the dataline upon request from the master device.

Figure 1 shows the basic bus connections between master and slave device. The buses are shared by a number of devices and are pulled high by a pull-up resistor.

### Serial Interface Specifications

Figure 2 shows the basic transmission specification. To begin and end a transmission, the master device generates a start signal (S) and a stop signal (P). Start (S) is defined as switching the S<sub>data</sub> from HIGH to LOW while the S<sub>clk</sub> is at HIGH. Similarly, stop (P) is defined as switching the S<sub>data</sub> from LOW to HIGH while holding the S<sub>clk</sub> HIGH. Between these two signals, data on S<sub>data</sub> is synchronous with the clock on the S<sub>clk</sub>. Data is allowed to change only at LOW period of clock, and must be stable at the HIGH period of clock. To acknowledge, drive the S<sub>data</sub> LOW before the S<sub>clk</sub> rising edge and hold it LOW until the S<sub>clk</sub> falling edge.

### Serial Interface Format

Each slave carries an address. The data transfer is initiated by a start signal (S). Each transfer segment is 1 byte in length. The slave address and the read/write bit are first sent from the master device after the start signal. The addressed slave device must acknowledge (Ack) the master device. Depending on the Read/Write bit, the master device will either write data into (logic 0) or read data (logic 1) from the slave device. Each time a byte of data is successfully transferred, the receiving device must acknowledge. At the end of the transfer, the master device will generate a stop signal (P).

### Serial Interface Transfer Format

Figure 2 shows the serial interface transfer format used with the CY2213. Two dummy bytes must be transferred before the first data byte. The CY2213 has only three bytes of latches to store information, and the third byte of data is reserved. Extra data will be ignored.

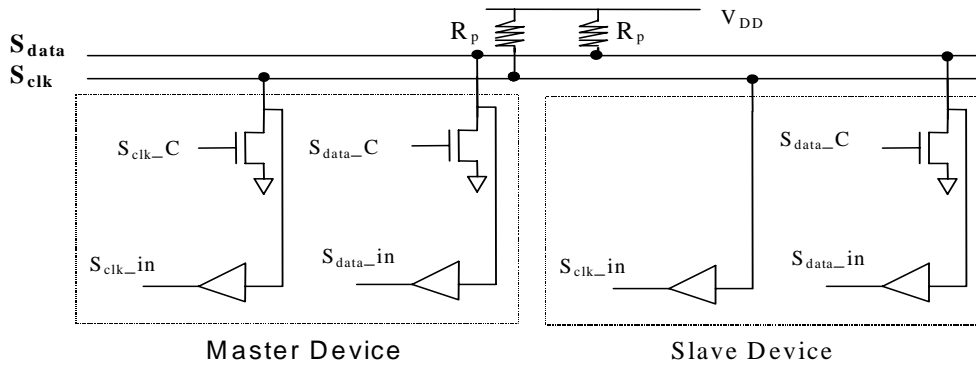

Figure 1. Device Connections

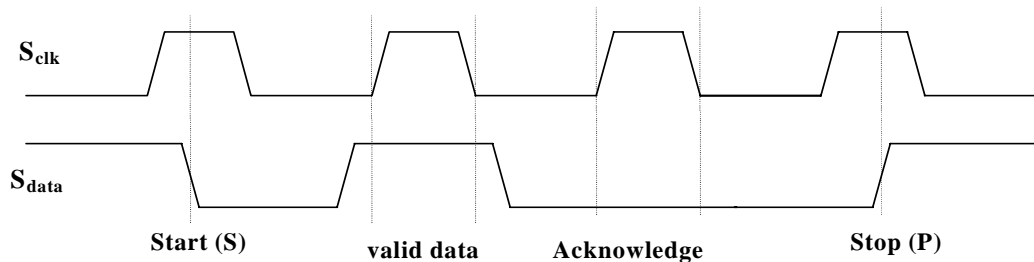

Figure 2. Serial Interface Specifications

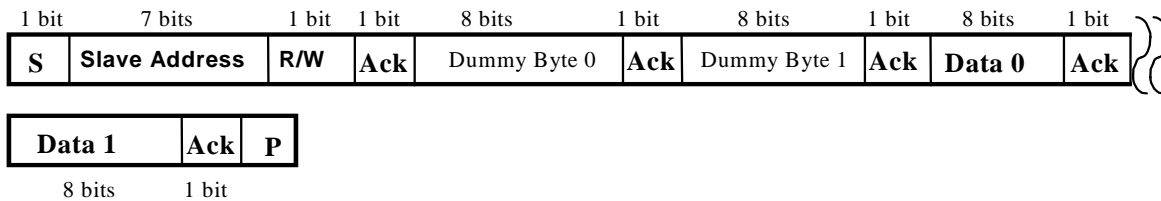

Figure 3. CY2213 Transfer Format

**Serial Interface Address for the CY2213**

A6	A5	A4	A3	A2	A1	A0	R/W
1	1	0	0	1	0	1	0

**Serial Interface Programming for the CY2213**

	b7	b6	b5	b4	b3	b2	b1	b0
Data0	QCNTBYP	SELPQ	Q<5>	Q<4>	Q<3>	Q<2>	Q<1>	Q<0>
Data1	P<7>	P<6>	P<5>	P<4>	P<3>	P<2>	P<1>	P<0>
Data2	Reserved	Reserved	Reserved	Reserved	Reserved	Reserved	Reserved	Reserved

To program the CY2213 using the two-wire serial interface, set the SELPQ bit HIGH. The default setting of this bit is LOW. The P and Q values are determined by the following formulas:

$$P_{final} = (P_{7..0} + 3) * 2$$

$$Q_{final} = Q_{5..0} + 2.$$

If the QCNTBYP bit is set HIGH, then Q<sub>final</sub> defaults to a value of 1. The default setting of this bit is LOW.

If the SELPQ bit is set LOW, the PLL multipliers will be set using the values in the Select Function Table.

CyberClocks™ has been developed to generate P and Q values for stable PLL operation. This software is downloadable from [www.cypress.com](http://www.cypress.com).

PLL Frequency = Reference x P/Q = Output

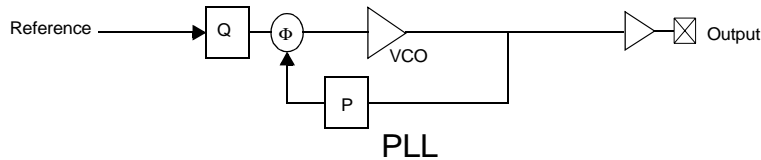

Figure 4. PLL Block Diagram

### Absolute Maximum Conditions

The following table reflects stress ratings only, and functional operation at the maximums are not guaranteed.

Parameter	Description	Min.	Max.	Unit
V <sub>DD,ABS</sub>	Max. voltage on V <sub>DD</sub> , or V <sub>DDX</sub> with respect to ground	-0.5	4.0	V
V <sub>I,ABS</sub>	Max. voltage on any pin with respect to ground	-0.5	V <sub>DD</sub> +0.5	V

### Crystal Requirements

Requirements to use parallel mode fundamental xtal. External capacitors are required in the crystal oscillator circuit. Please refer to the application note entitled *Crystal Oscillator Topics* for details.

Parameter	Description	Min.	Max.	Unit
X <sub>F</sub>	Frequency	10	31.25	MHz

### DC Electrical Specifications

Parameter	Description	Min.	Max.	Unit
V <sub>DD</sub>	Supply voltage	3.00	3.60	V
T <sub>A</sub>	Ambient operating temperature	0	70	°C
V <sub>IL</sub>	Input signal low voltage at pin S		0.35	V <sub>DD</sub>
V <sub>IH</sub>	Input signal high voltage at pin S	0.65		V <sub>DD</sub>
R <sub>PUP</sub>	Internal pull-up resistance	10	100	kΩ
t <sub>PU</sub>	Power-up time for all V <sub>DD</sub> S to reach minimum specified voltage (power ramps must be monotonic)	0.05	500	ms

### AC Electrical Specifications

Parameter	Description	Min.	Max.	Unit
f <sub>IN</sub>	Input frequency with driven reference	1	133	MHz
f <sub>XTAL,IN</sub>	Input frequency with crystal input	10	31.25	MHz
C <sub>IN,CMOS</sub>	Input capacitance at S pin <sup>[1]</sup>		10	pF

#### 3.3V DC Device Characteristics (Driving load, Figure 5)

Parameter	Description	Min.	Typ.	Max.	Unit
V <sub>OH</sub>	Output high voltage, referenced to V <sub>DD</sub>	-1.02	-0.95	-0.88	V
V <sub>OL</sub>	Output low voltage, referenced to V <sub>DD</sub>	-1.81	-1.70	-1.62	V

#### 3.3V DC Device Characteristics (Driving load, Figure 6)

Parameter	Description	Min.	Typ.	Max.	Unit
V <sub>OH</sub>	Output high voltage	1.1	1.2	1.3	V
V <sub>OL</sub>	Output low voltage	0	0	0	V

**Note:**

- Capacitance measured at freq. = 1 MHz, DC Bias = 0.9V, and VAC < 100 mV.

**State Transition Characteristics**

Specifies the maximum settling time of the CLK and CLKB outputs from device power-up. For  $V_{DD}$  and  $V_{DDX}$  any sequences are allowed to power-up and power-down the CY2213.

From	To	Transition Latency	Description
$V_{DD}/V_{DDX}$ On	CLK/CLKB Normal	3 ms	Time from $V_{DD}/V_{DDX}$ is applied and settled to CLK/CLKB outputs settled.

**AC Device Characteristics**

Parameter	Description	Min.	Max.	Unit
$t_{CYCLE}$	Clock cycle time	2.50 (400 MHz)	8.00 (125 MHz)	ns
$t_{JCRMS}$	Cycle-to-cycle RMS jitter		0.25%	% $t_{CYCLE}$
	At 125-MHz frequency		20	ps
	At 400-/500-MHz frequency		6.25/5	ps
$t_{JCPK}$	Cycle-to-cycle jitter (pk-pk)		1.75%	% $t_{CYCLE}$
	At 125-MHz frequency		140	ps
	At 200-MHz frequency, XF = 25 MHz		55	ps
	At 400-/500-MHz frequency		43.75/35	ps
$t_{JPRMS}$	Period jitter RMS		0.25%	% $t_{CYCLE}$
	At 125-MHz frequency		20	ps
	At 400-/500-MHz frequency		6.25/5	ps
$t_{JPPK}$	Period jitter (pk-pk)		2.0%	% $t_{CYCLE}$
	At 125-MHz frequency		160	ps
	At 200-MHz frequency, XF = 25 MHz		65	ps
	At 400-/500-MHz frequency		50/40	ps
$t_{JLT}$	Long term RMS Jitter (P < 20)		1.75%	% $t_{CYCLE}$
	At 125-MHz frequency		140	ps
	At 400-/500-MHz frequency		43.75/35	ps
$t_{JLT}$	Long term RMS Jitter (20 ≤ P < 40)		2.5%	% $t_{CYCLE}$
	At 125-MHz frequency		200	ps
	At 400-/500-MHz frequency		62.5/50	ps
$t_{JLT}$	Long-term RMS Jitter (40 ≤ P < 60)		3.5%	% $t_{CYCLE}$
	At 125-MHz frequency		280	ps
	At 400-/500-MHz frequency		87.5/70	ps
Phase Noise	Phase Noise at 10 kHz (x8 mode) @ 125 MHz	-107	-92	dBc
DC	Long-term average output duty cycle	45	55	%
$t_{DC,ERR}$	Cycle-cycle duty cycle error at x8 with 15.625-MHz input		70	ps
$t_{CR}, t_{CF}$	Output rise and fall times (measured at 20% – 80% of $V_{OHmin}$ and $V_{OLmax}$ )	100	400	ps
$BW_{LOOP}$	PLL Loop Bandwidth	50 kHz (-3 dB)	8 MHz (-20 dB)	

## Functional Specifications

### Crystal Input

The CY2213 receives its reference from an external crystal. Pin XIN is the reference crystal input, and pin XOUT is the reference crystal feedback. The parameters for the crystal are given on page 5 of this data sheet. The oscillator circuit requires external capacitors. Please refer to the application note entitled *Crystal Oscillator Topics* for details.

### Select Input

There is only one select input, pin S. This pin selects the frequency multiplier in the PLL, and is a standard LVCMOS input. The S pin has an internal pull-up resistor. The multiplier selection is given on page 2 of this data sheet.

### PECL Clock Output Driver

Figure 5 and Figure 6 show the clock output driver.

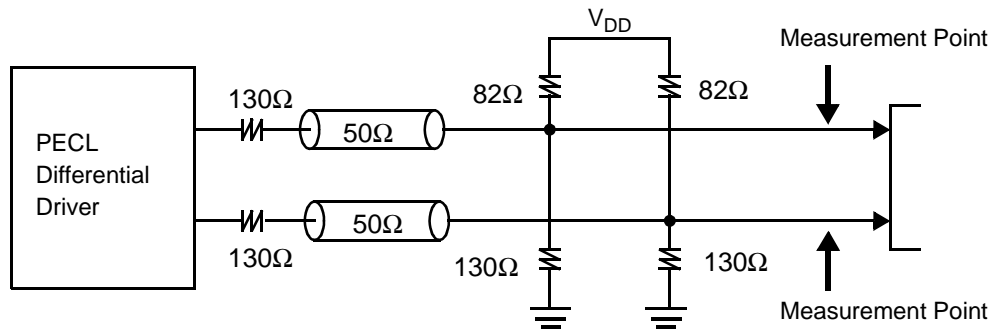

Figure 5. Output Driving Load (-1)

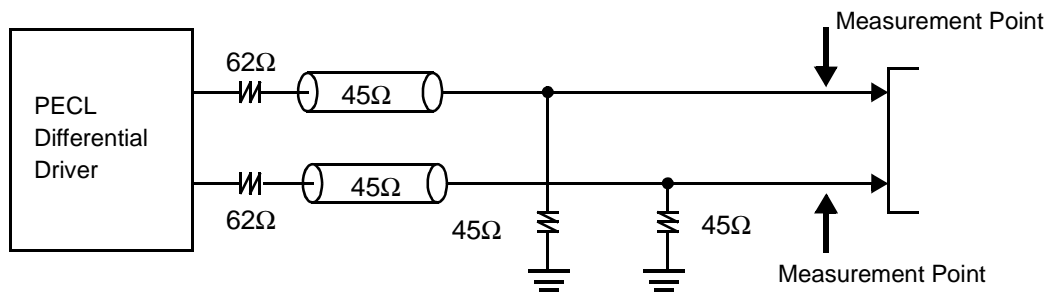

Figure 6. Output Driving Load (-2)

An alternative termination scheme can be used to drive a standard PECL fanout buffer

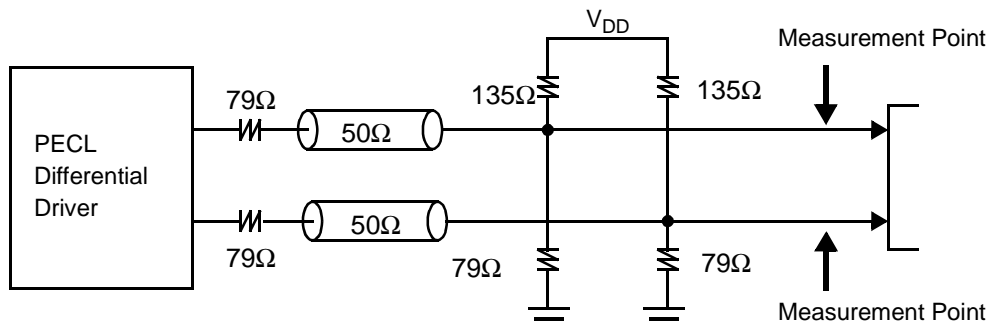

Figure 7. Output Driving Load(-3)

The PECL differential driver is designed for low-voltage, high-frequency operation. It significantly reduces the transient switching noise and power dissipation when compared to conventional CMOS drivers. The nominal value of the channel impedance is 50Ω. The pull-up and pull-down resistors provide matching channel termination. The combination of the differential driver and the output network determines the voltage swing on the channel. The output clock is specified at the measurement point indicated in *Figure 5* and *Figure 6*.

Input and Output voltage waveforms are defined as shown in *Figure 8*. Rise and fall times are defined as the 20% and 80% measurement points of  $V_{OHmin} - V_{OLmax}$ .

The device parameters are defined in *Table 1*. *Figure 9* shows the definition of long-term duty cycle, which is simply the CLK waveform high-time divided by the cycle time (defined at the crossing point). Long-term duty cycle is the average over many (> 10,000) cycles. DC is defined as the output clock long-term duty cycle.

### Signal Waveforms

A physical signal that appears at the pins of the device is deemed valid or invalid depending on its voltage and timing relations with other signals. This section defines the voltage and timing waveforms for the input and output pins of the CY2213. The Device Characteristics tables list the specifications for the device parameters that are defined here.

**Table 1. Definition of Device Parameters**

Parameter	Definition
$V_{OH}, V_{OL}$	Clock output high and low voltages
$V_{IH}, V_{IL}$	$V_{DD}$ LVCMOS input high and low voltages
$t_{CR}, t_{CF}$	Clock output rise and fall times

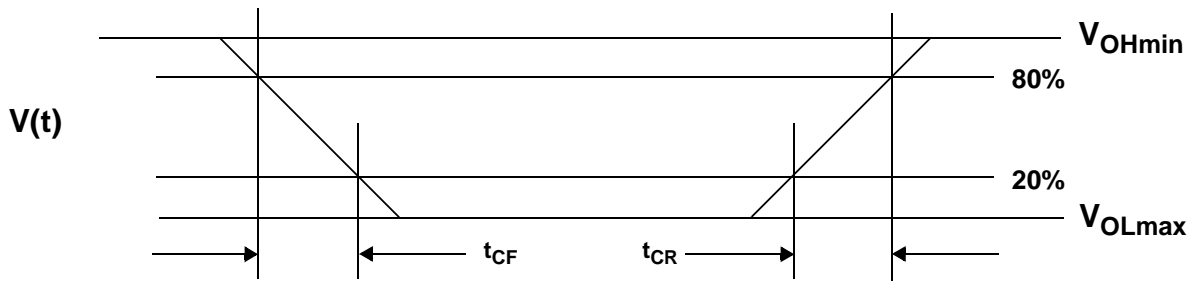

**Figure 8. Voltage Waveforms**

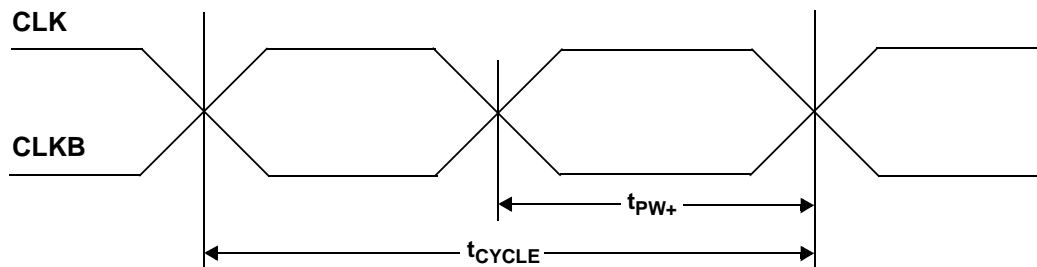

$$DC = t_{PW+} / t_{CYCLE}$$

**Figure 9. Duty Cycle Jitter**

### Jitter

This section defines the specifications that relate to timing uncertainty (or jitter) of the input and output waveforms. *Figure 10* shows the definition of period jitter with respect to the falling edge of the CLK signal. Period jitter is the difference between the minimum and maximum cycle times over many cycles (typically 12800 cycles at 400 MHz). Equal require-

ments apply for rising edges of the CLK signal.  $t_{JP}$  is defined as the output period jitter.

*Figure 11* shows the definition of cycle-to-cycle jitter with respect to the falling edge of the CLK signal. Cycle-to-cycle jitter is the difference between cycle times of adjacent cycles over many cycles (typically 12800 cycles at 400 MHz). Equal requirements apply for rising edges of the CLK signal.  $t_{JC}$  is defined as the clock output cycle-to-cycle jitter.

Figure 12 shows the definition of cycle-to-cycle duty cycle error. Cycle-to-cycle duty cycle error is defined as the difference between high-times of adjacent cycles over many cycles (typically 12800 cycles at 400 MHz). Equal requirements apply to the low-times.  $t_{DC,ERR}$  is defined as the clock output cycle-to-cycle duty cycle error.

Figure 13 shows the definition of long-term jitter error. Long-term jitter is defined as the accumulated timing error over many cycles (typically 12800 cycles at 400 MHz). It applies to both rising and falling edges.  $t_{JLT}$  is defined as the long-term jitter.

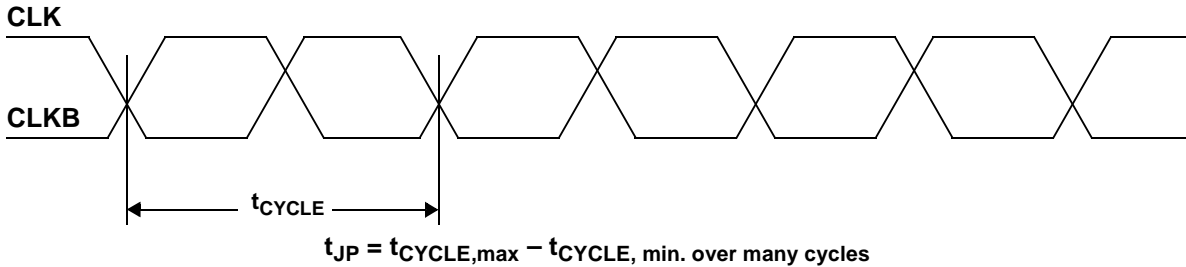

Figure 10. Period Jitter

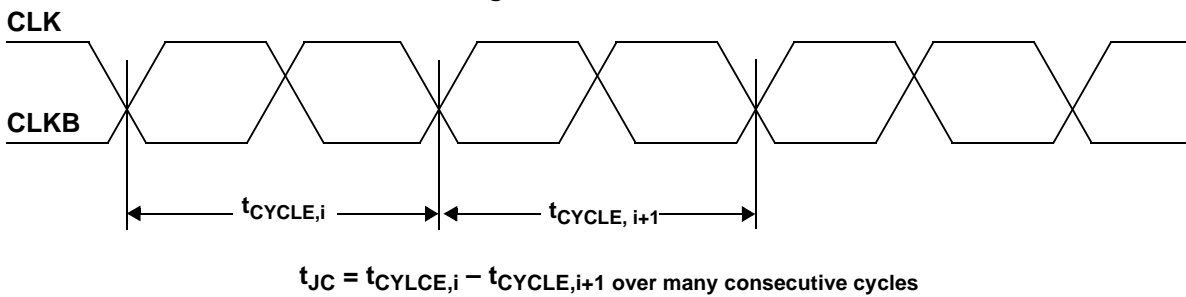

Figure 11. Cycle-to-cycle Jitter

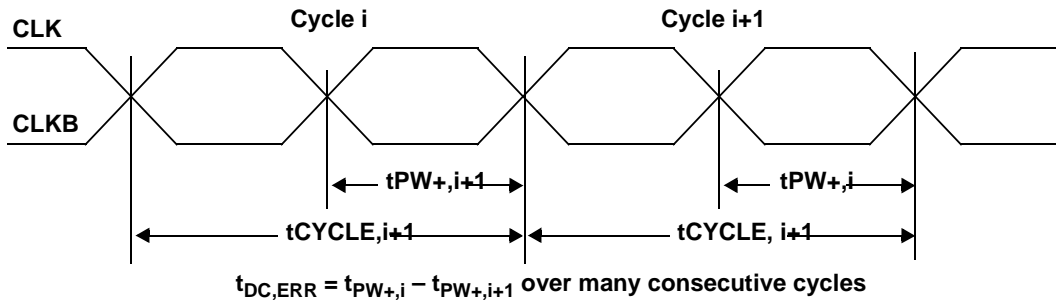

Figure 12. Cycle-to-cycle Duty Cycle Error

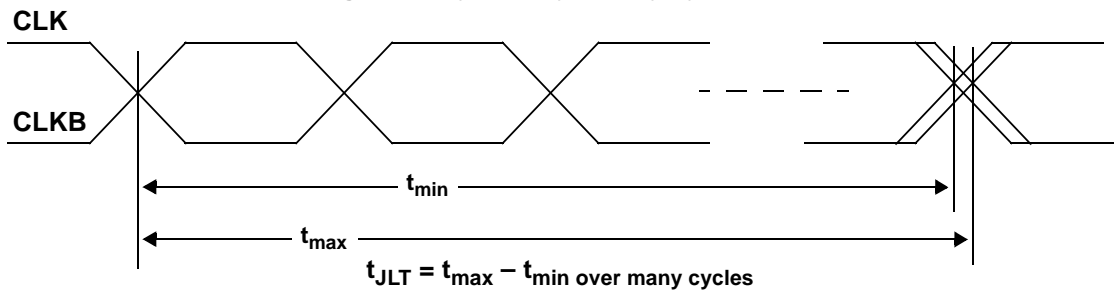

Figure 13. Long-term Jitter



**Ordering Information**

Ordering Code	Package Type	Operating Range	Operating Voltage
CY2213ZC-1	16-lead TSSOP	Commercial, to 400 MHz	3.3V
CY2213ZC-1T	16-lead TSSOP – Tape and Reel	Commercial, to 400 MHz	3.3V
CY2213ZC-2	16-lead TSSOP	Commercial, to 500 MHz	3.3V
CY2213ZC-2T	16-lead TSSOP – Tape and Reel	Commercial, to 500 MHz	3.3V

**Package Drawing and Dimensions**

**16-Lead Thin Shrunken Small Outline Package (4.40 MM Body) Z16**

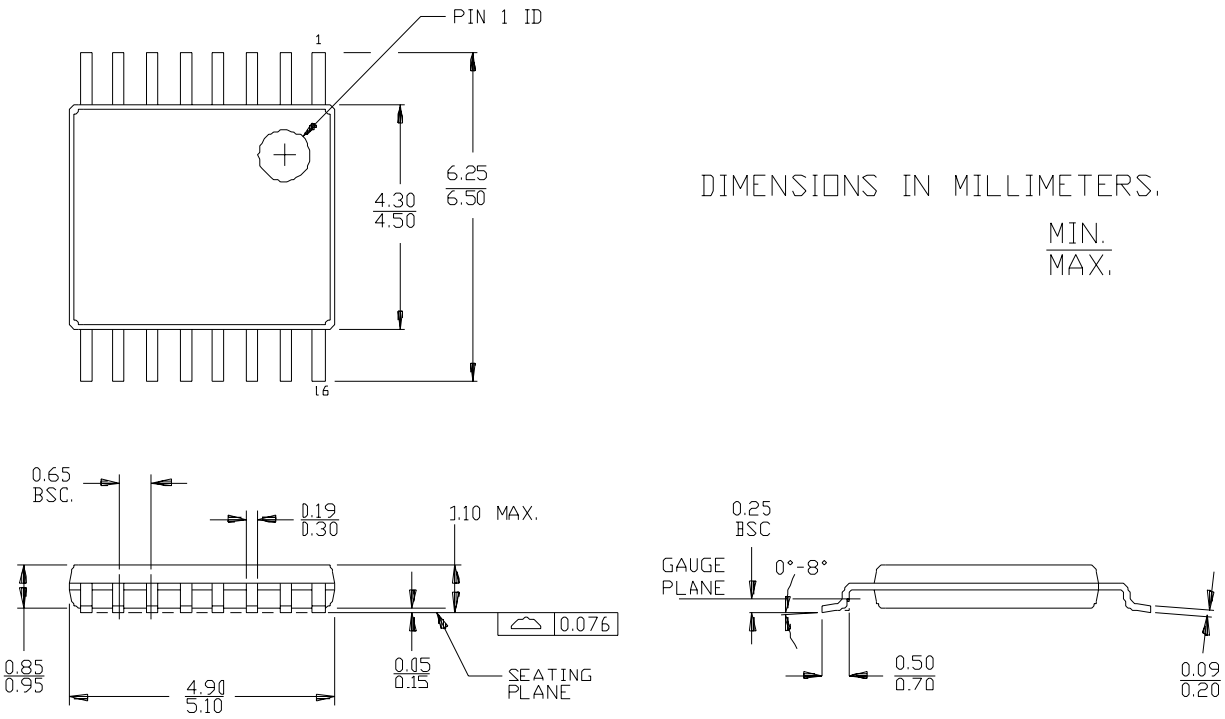

51-85091-\*\*

CyberClocks is a trademark of Cypress Semiconductor. All product and company names mentioned in this document may be the trademarks of their respective holders.

## Document History Page

Document Title: CY2213 High-Frequency Programmable PECL Clock Generator				
Document Number: 38-07263				
REV.	ECN NO.	Issue Date	Orig. of Change	Description of Change
**	113090	02/06/02	DSG	Change from Spec number: 38-01100 to 38-07263
*A	113512	05/24/02	CKN	Added PLL Block Diagram ( <i>Figure 4</i> ) and PLL frequency equation
*B	121882	12/14/02	RBI	Power-up requirements added to Operating Conditions
*C	123215	12/19/02	LJN	Previous revision was released with incorrect *A numbering in footer; *A should have been *B (and was changed accordingly)
*D	124012	03/05/03	CKN	Added -2 to data sheet; edited line 3 of Benefits
*E	126557	05/27/03	RGL	Added 200-MHz Jitter Spec. Added optional output termination