

FEATURES

- **BROAD FREQUENCY RESPONSE:** To 1200 MHz TYP at 3 dB Down
- **HIGH POWER GAIN:** 19 dB TYP at $f = 500$ MHz
- **LOW VOLTAGE OPERATION:** $V_{CC} = 5$ V
- **SMALL PACKAGE**

DESCRIPTION

The UPC1651G is a silicon monolithic integrated circuit especially designed as a wide band amplifier covering the HF band through UHF band.

OUTLINE DIMENSIONS (Units in mm)

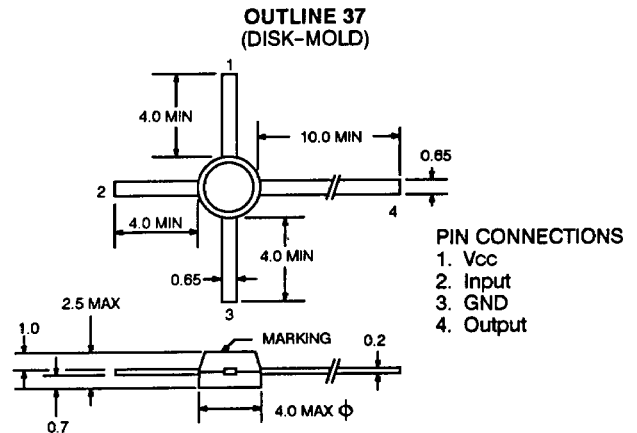

EQUIVALENT CIRCUIT

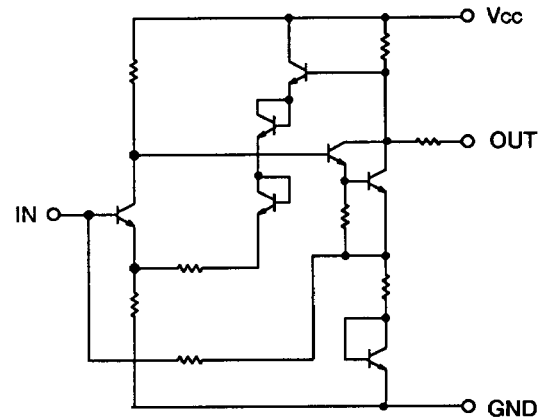

ABSOLUTE MAXIMUM RATINGS ($T_A = 25^\circ\text{C}$)

SYMBOLS	PARAMETERS	UNITS	RATINGS
V_{CC}	Supply Voltage	V	6
P_T	Total Power Dissipation	mW	250
T_{OP}	Operating Temperature	$^\circ\text{C}$	-20 to +75
T_{STG}	Storage Temperature	$^\circ\text{C}$	-40 to +125

ELECTRICAL CHARACTERISTICS ($T_A = 25^\circ\text{C}$)

PART NUMBER PACKAGE OUTLINE			UPC1651G 37		
SYMBOLS	PARAMETERS AND CONDITIONS	UNITS	MIN	TYP	MAX
I_{CC}	Circuit Current at $V_{CC} = 5$ V	mA	15	20	25
NF	Noise Figure at $V_{CC} = 5$ V, $f = 500$ MHz	dB		5.5	6.5
BW	Bandwidth at $V_{CC} = 5$ V, 3 dB down	MHz	1000	1200	
P_{OUT}	Maximum Output Level at $V_{CC} = 5$ V, $f = 500$ MHz	dBm	3	5	
$ S_{21} $	Power Gain at $V_{CC} = 5$ V, $f = 500$ MHz	dB	16	19	
$ S_{11} $	Input Return Loss at $V_{CC} = 5$ V, $f = 500$ MHz	dB		15	
$ S_{22} $	Output Return Loss at $V_{CC} = 5$ V, $f = 500$ MHz	dB		10	
$ S_{12} $	Isolation at $V_{CC} = 5$ V, $f = 500$ MHz	dB	20	24	

TYPICAL PERFORMANCE CHARACTERISTICS ($T_A = 25^\circ\text{C}$)

TOTAL POWER DISSIPATION vs. AMBIENT TEMPERATURE

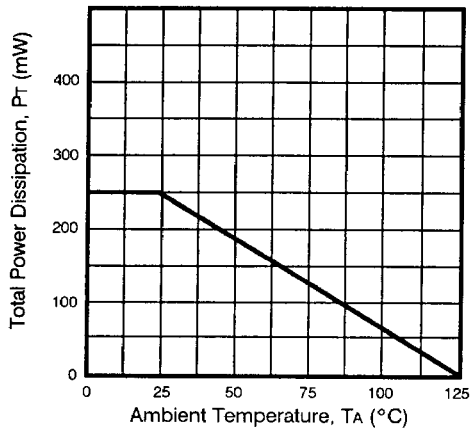

CIRCUIT CURRENT vs. SUPPLY VOLTAGE

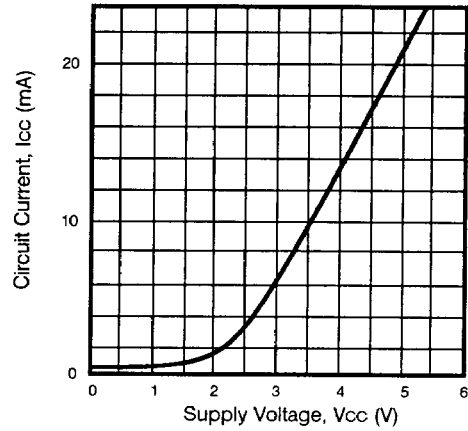

NOISE FIGURE AND POWER GAIN vs. FREQUENCY

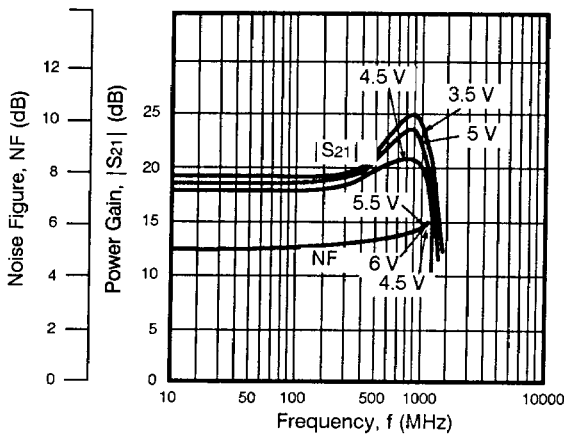

INPUT POWER vs. OUTPUT POWER

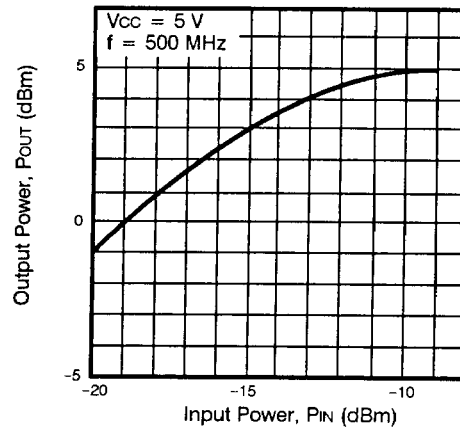

INPUT AND OUTPUT RETURN LOSS vs. FREQUENCY

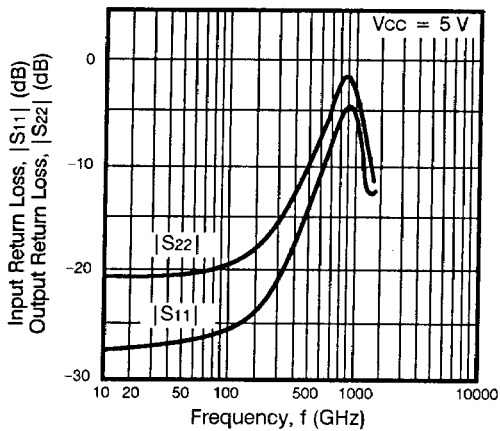

ISOLATION vs. FREQUENCY

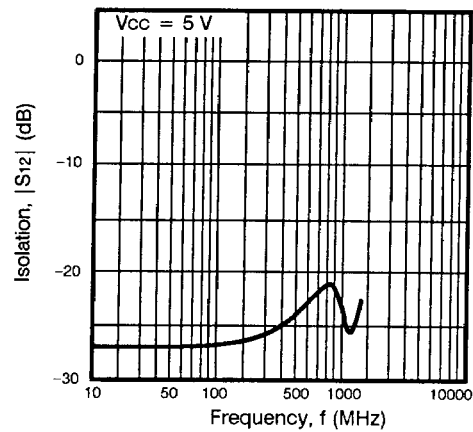

4